

**Chief Architect®
Home Designer® Pro 2014**

Reference Manual

**Chief Architect, Inc.
6500 N. Mineral Dr.
Coeur d'Alene, Idaho 83815
www.HomeDesignerSoftware.com**

© 1990–2012 by Chief Architect, Inc. All rights reserved.

No part of this book or the accompanying software may be reproduced or transmitted in any form or by any means, electronic or mechanical, including photocopying, recording, or by any information storage and retrieval system, without permission in writing from Chief Architect, Inc.

Chief Architect® and Home Designer® are registered trademarks of Chief Architect, Inc.

This software uses the FreeImage open source image library. See <http://freeimage.sourceforge.net> for details.

FreeImage is used under the FIPL license, version 1.0.

This software uses the Ruby open source library. See <http://www.ruby-lang.org/> for details.

All other trademarks and copyrights are the property of Chief Architect, Inc. or their respective owners.

Created in the United States of America.

Contents

Chapter 1: Program Overview

Startup Options.....	24
The Home Designer Pro Environment	25
Toolbars.....	28
Menus.....	30
Dialogs	30
The Status Bar.....	31
Message Boxes.....	32
Preferences and Default Settings.....	33
Drawing a Plan	33
Viewing Your Plan.....	35
Getting Help.....	37
About Home Designer Pro	37
Upgrade to Chief Architect	38

Chapter 2: File Management

Compatibility with Other Programs.....	40
Organizing Your Files.....	40
Home Designer Pro Data.....	41
Creating a New Plan or Layout.....	42
Saving, Exporting, and Backing Up Files	43
Thumbnail Images	46
Auto Archive.....	46

Undo Files	48
Opening and Importing Files	48
Searching for Plans	50
Backup Entire Plan	52
Closing Views and Files.....	53
Exiting Home Designer Pro	54

Chapter 3: Preferences & Default Settings

Default Settings vs Preferences.....	56
Dynamic Defaults.....	57
General Plan Defaults Dialog.....	58
Reset to Defaults	59
Preferences Dialog	60
Number Style/Angle Style Dialog	89

Chapter 4: Toolbars & Hotkeys

Toolbar Arrangement	92
Customizing Toolbars	93
Toolbar Configurations	98
Hotkeys.....	99

Chapter 5: Layers

Displaying Objects	102
Layer Sets.....	103
Layer Display Options Dialog.....	104

Chapter 6: Creating Objects

Architectural vs CAD Objects.....	108
--	------------

Defaults and Preferences	108
Snap Behaviors	109
Object Snaps	110
Angle Snaps	111
Grid Snaps	112
Creating Objects	112
Copying and Pasting Objects	114

Chapter 7: Editing Objects

Defaults and Preferences	120
Edit Behaviors	120
Selecting Objects	124
Editing Line Based Objects	127
Editing Arc Based Objects	130
Editing Open Polyline Based Objects	134
Editing Closed-Polyline Based Objects	138
Editing Box-Based Objects	141
Editing Spline Based Objects	144
Editing Circles, Ovals and Ellipses	146
Displaying Objects	149
Moving Objects	152
Aligning Objects	154
Resizing Objects	157
Reshaping Objects	158
Rotating Objects	161
Reflecting Objects	163
Converting Objects	164
Transform/Replicate Object Dialog	166
Edit Area Tools	168
Deleting Objects	171

Undo and Redo 173

Chapter 8: Walls, Railings & Fencing

Wall, Railing, and Fencing Defaults 176
The Wall Tools 181
The Deck Tools 182
The Fencing Tools 183
Exterior and Interior Walls 183
Foundation Walls 183
Pony Walls 184
Railings 185
Invisible Walls 186
Polygon Shaped Decks 187
Hatch Wall 188
Break Wall 189
Drawing Walls 189
Connecting Walls 191
Displaying Walls 192
Measuring Walls 195
Editing Walls 197
Editing Straight/Curved Wall Combinations 201
Aligning Walls 201
Roof Directives in Walls 204
Attic Walls 206
Stepped and Raked Walls 206
CAD to Walls 208
Wall Type Definitions 209
Wall Type Definitions Dialog 211
Wall Specification Dialog 214
Railing and Fencing Specification Dialogs 224

Wall Hatch Specification Dialog	227
---------------------------------------	-----

Chapter 9: Rooms

Floor and Room Defaults	230
Room Definition	231
Selecting Rooms.....	231
Displaying Rooms.....	232
Editing Rooms.....	233
Room Types	234
Room Labels	236
Decks	238
Floor & Ceiling Heights	239
Special Ceilings	241
Room Specification Dialog	244

Chapter 10: Doors

Door Defaults	253
The Door Tools.....	254
Displaying Doors	257
Editing Doors	258
Changing Door Swings	260
Special Doors	263
Door Specification Dialog	265

Chapter 11: Windows

Window Defaults	280
The Window Tools	280
Special Windows.....	282
Grouped Windows	284

Window Levels	285
Displaying Windows	287
Editing Windows	289
Bay, Box, and Bow Windows	290
Bay, Box, Bow Windows & Roofs	292
Window Specification Dialog	294
Bay/Box Window Specification Dialog	311
Bow Window Specification	313

Chapter 12: Multiple Floors

Floor Defaults Dialog	316
Floor Tools	317
Adding Floors	317
Displaying Floors	319
Copying Floors	320
Deleting Floors	320
Floor and Ceiling Platforms	321
Floor and Ceiling Platform Definitions	322
Rebuilding Walls, Floors & Ceilings	324
Split Levels	325
The Current Floor	326
The Attic Floor	327
The Reference Floor	327

Chapter 13: Foundations

Foundation Defaults	330
Building a Foundation	334
Displaying Foundations	335
Editing Foundations	335
Aligning Foundation Walls	337

Deleting Foundations	338
Foundations and Rooms	338
Foundations and the Terrain	339
The Slab Tools	341
Editing Slabs	341
Editing Piers and Pads	341
Slab Specification Dialog	342
Fireplaces	343
Fireplace Specification Dialog	345
Library Fireplaces	347
Chimneys	347

Chapter 14: Roofs

Automatic vs. Manual Roofs	350
Roof Defaults	351
The Roof Tools	352
Automatic Roofs	353
Build Roof Dialog	355
Roof Planes	362
Displaying Roofs	364
Editing Roof and Ceiling Planes	365
Roof Plane Specification Dialog	371
Roof Baseline Polylines	375
Roof Baseline Specification Dialog	377
Roof and Ceiling Framing	378
Ceiling Planes	379
Ceiling Plane Specification Dialog	380
Gable/Roof Lines	382
Skylights	385
Roof Hole/Skylight Specification Dialog	386

Dormers and Crickets	387
Editing Auto Dormers.....	390
Dormer Specification Dialog.....	391
Roof Returns and Other Details	393
Roof Pitches in Degrees	395

Chapter 15: Stairs, Ramps & Landings

Stair and Ramp Defaults	398
The Stair Tools.....	398
Anatomy of a Staircase.....	399
Drawing Stairs and Ramps	400
Displaying Stairs, Ramps, and Landings	402
Editing Stairs and Ramps	403
Merging Stair and Ramp Sections	404
Landings.....	406
Maintaining Tread Depth.....	409
..... Flared Stairs and Curved Treads	410
Starter Treads	413
Winders.....	414
Wrapped Stairs	415
Other Special Railings & Stairs	416
Creating a Stairwell	419
Rooms Below Staircases	421
Staircase Specification Dialog	422
Ramp Specification Dialog	430
Stair Landing Specification Dialog	433

Chapter 16: Framing

Framing Defaults	436
Manual vs. Automatic Framing.....	437

The Framing Tools.....	440
Build Framing Dialog.....	443
Framing Reference Markers.....	454
Bearing Lines	456
Joist Direction Lines.....	457
Displaying Framing.....	458
Editing Framing.....	460
Keeping Framing Current.....	461
Framing and the Materials List	462
Framing Specification Dialog	463
Post Specification Dialog.....	465

Chapter 17: Trusses

Truss Defaults	470
Floor and Ceiling Trusses.....	470
Roof Trusses	470
Drawing Trusses	471
Displaying Trusses	472
Editing Trusses	473
Editing Truss Envelopes	474
Truss Labels.....	474
Mixing Trusses with Stick Framing.....	475
Hip Trusses	475
Special Roof Trusses	476
Roof Truss Specification Dialog.....	479
Floor/Ceiling Truss Specification Dialog.....	482

Chapter 18: Electrical

Electrical Defaults.....	486
The Electrical Tools	487

Creating Wiring Schematics	488
Auto Place Outlets.....	489
Electrical Library.....	489
Displaying Electrical Objects	490
Editing Electrical Objects	490
Electrical Service Specification Dialog.....	492

Chapter 19: Trim & Molding

Trim and Molding Defaults.....	498
Corner Boards.....	498
Corner Board Specification Dialog	499
Quoins	500
Quoin Specification Dialog	501
Editing Corner Boards and Quoins.....	503
Millwork	503
Moldings Tab.....	503

Chapter 20: Cabinets

Cabinet Defaults	507
The Cabinet Tools.....	509
Cabinet Fillers.....	511
Placing Cabinets.....	512
Custom Countertops	513
Displaying Cabinets	514
Cabinet Labels	515
Editing Cabinets	517
Editing Cabinet Styles.....	518
Editing Custom Countertops.....	519
Special Cabinets.....	520
Cabinet Specification Dialog	522

Cabinet Shelf Specification Dialog.....	532
Shelf/Partition Specification Dialog	533
Custom Countertop Specification Dialog.....	535

Chapter 21: Terrain

Terrain Toolbar Configuration	538
Terrain Perimeter	538
Elevation Data Tools.....	540
Terrain Modifier Tools	545
Terrain Feature Tools	546
Garden Bed Tools	548
Water Feature Tools	548
Stepping Stone Tools	549
Terrain Wall and Curb Tools	549
Sun Shadows	550
Terrain Objects in the Library	551
Displaying Terrain.....	551
Editing Terrain Objects	552
Terrain Object Specification Dialogs	553
Terrain Specification Dialog	554
Elevation Point Specification Dialog.....	557
Elevation Line/Region Specification Dialog	559
Flat Region Specification Dialog	560
Hill / Valley Specification Dialog.....	561
Raised / Lowered Region Specification Dialog	562
Terrain Feature Specification Dialog	562
Garden Bed Specification Dialog	564
Terrain Break Specification Dialog	564
Terrain Path Specification Dialog.....	566
Importing Elevation Data.....	567

Import Terrain Wizard.....	568
Import GPS Data Wizard	570
Importing DXF Elevation Data	572
Converting CAD Lines to Terrain Data	573
Plant Tools	573
Plant Image Specification Dialog	574
Plant Chooser Dialog	577
Hardiness Zones.....	579
Sprinkler Tools.....	580
Sprinkler Specification Dialog.....	580

Chapter 22: Roads, Driveways & Sidewalks

Road, Driveway and Sidewalk Tools.....	584
Displaying Road Objects	585
Editing Road Objects	586
Road Specification Dialog	586

Chapter 23: Other Objects

General Shapes.....	589
Soffits.....	589
Special Applications for Soffits.....	590
Calculating Materials on Soffits	592
Soffit Specification Dialog	592

Chapter 24: Architectural Blocks

Creating Architectural Blocks	597
Displaying Architectural Blocks.....	599
Editing Architectural Blocks.....	599
Architectural Blocks, Sub-Objects, and Components	600

Chapter 25: The Library

The Library Browser	604
Searching the Library	608
Library Content	609
Downloading Library Content.....	611
Importing Library Catalogs	612
Adding Library Content.....	613
Organizing the Library.....	615
Filtering the Display of Library Content	618
Exporting Library Catalogs.....	620
Placing Library Objects.....	620
Select Library Object Dialog	622
Place Library Object Button.....	623
Replace From Library	624
Displaying Library Objects	624
Editing Library Objects	625
Symbol Object Specification Dialogs	627

Chapter 26: Materials

About Materials	632
The Material Painter	632
Materials Tab	635
Viewing Materials.....	636
Editing Materials	636
Creating Materials.....	637
Mapping Patterns and Textures	638
Material Types	640
Managing Plan Materials	642
Define Material Dialog	644

Material Defaults	651
Color Chooser Dialog.....	652

Chapter 27: Zoom & View Tools

Zoom Tools	654
Undo Zoom.....	654
Fill Window.....	655
Panning the Display	655
Swapping Views.....	656
Window Menu Tools	656
Cascade	657
Tiling Views	659
Arrange Icons.....	660
Aerial View	660
Closing Views	661

Chapter 28: 3D Views

OpenGL and Hardware.....	664
Types of 3D Views	664
Defaults and 3D Preferences	665
Camera Defaults Dialog	665
3D View Defaults Dialog.....	668
3D View Tools	672
Creating Camera Views.....	673
Creating Overviews	674
Cross Section/Elevation Views	675
Displaying 3D Views.....	677
Repositioning Cameras.....	680
Editing 3D Views.....	684
Cross Section Slider.....	686

Working in 3D	687
Saving & Printing 3D Views	690
Camera Specification Dialog	691
Cross Section/Elevation Camera Specification	694

Chapter 29: 3D Rendering

Rendering Tips.....	697
Lighting.....	699
Displaying Lights.....	703
Light Types.....	705
Light Specification Dialog.....	706
Default Sun Light Specification Dialog.....	707
Sun Angle Specification Dialog.....	708
Rendering Techniques	710
Rendering Technique Options.....	713
Speeding up 3D View Generation.....	716

Chapter 30: Dimensions

Compatibility With Previous Versions	719
Dimension Preferences and Defaults	719
Dimension Defaults Dialog	720
Auto Dimension Defaults Dialogs	727
The Dimension Tools.....	728
Displaying Dimension Lines.....	732
Editing Dimension Lines	733
Editing Extension Lines	735
Moving Objects Using Dimensions.....	737
Dimension Line Specification Dialog.....	739

Chapter 31: Text, Callouts & Markers

Text Defaults and Preferences	744
Fonts and Alphabets	745
The Text Tools	746
Creating Text, Callouts and Markers	746
Displaying Text, Arrows, Callouts and Markers	747
Rich Text Specification Dialog	747
Text Specification Dialog	753
Editing Text	754
Copying & Pasting Text	756
Text Arrows	757
Callouts.....	759
Callout Specification Dialog	760
Editing Callouts	762
Markers.....	762
Marker Specification Dialog.....	763
Editing Markers.....	764
Text Styles.....	765

Chapter 32: CAD Objects

CAD Defaults and Preferences.....	770
The CAD Drawing Tools.....	771
Point Tools	772
Line Tools.....	776
Line Specification Dialog.....	780
Drawing Arcs - Arc Creation Modes	784
Arc Tools	785
Arc Specification Dialog	786
Circle Tools	788

CAD Circle/Oval/Ellipse Specification Dialog	789
Polylines	790
Polyline Specification Dialog.....	791
Box Tools.....	794
Box Specification Dialog.....	795
Splines	796
Displaying CAD Objects.....	798

Chapter 33: Project Management

House Wizard	799
Plan Check.....	801
Loan Calculator.....	802

Chapter 34: Pictures, Images, & Walkthroughs

Picture Files vs Pictures and Image Objects	806
Images.....	806
Displaying Images	807
Editing Images	808
Image Specification Dialog	809
Pictures.....	811
Picture File Box Specification Dialog	813
Metafiles.....	814
Metafile Box Specification Dialog	816
Displaying Pictures and Metafiles.....	817
Editing Pictures and Metafiles.....	817
Copy Region as Picture.....	819
Walkthroughs	819
Walkthrough Path Specification Dialog.....	823

Chapter 35: Importing & Exporting

DXF File Format	828
Importing 2D Drawings	828
Import Drawing Wizard.....	829
CAD to Walls	833
Exporting 2D DXF Files	833
Additional 2D Export Information	835
3D Data Import Requirements	836
Importing 3D Symbols.....	838
3D Symbols and Materials	838

Chapter 36: Printing & Plotting

Introduction to Printing.....	842
Printers and Plotters	843
The Printing Tools	844
Display Options and Printing	844
Printing Directly from a View.....	846
Printing from Layout	846
Printing to Scale	847
Printing Across Multiple Pages.....	848
Printing to a PDF File	848
Line Weights	849
Printing Text and Dimensions	851
Creating Custom Sheet Sizes.....	852
Page Setup Dialog	853
Print Dialog.....	855
Print Image Dialog	857
Print Model	858

Chapter 37: Layout

Layout Defaults	863
Preparing for Layout.....	864
Creating a Layout File	865
The Layout Tools	865
Sending Views to Layout	866
CAD and Text in Layout	868
Pictures and Metafiles in Layout	869
Keeping Layout Views Current.....	869
Editing Layout Views.....	870
Displaying Layout Views.....	872
Layout Page Display Options	872
Opening Layout Views	872
Managing Layout Links	873
Printing Layout Files	875
Exporting Layout Files	875
Layout Box Specification Dialog.....	875

Chapter 38: Plant Schedules & Object Labels

Creating and Editing Schedules.....	879
Schedule Specification Dialog.....	880
Columns to Include.....	884
Object Labels	884

Chapter 39: Materials Lists

The Materials List Tools	888
Creating an Accurate Materials List.....	889
Organizing Materials Lists	889
Materials List Display Options Dialog.....	891

Materials List Columns	892
Editing Materials Lists.....	895
Managing Materials Lists	896
Exporting the Materials List.....	897
Conditioned Area Totals	898
Structural Member Reporting.....	898
The Master List	899
Components Dialog.....	901

Appendix A: Additional Resources

Reference Manual	905
User's Guide.....	905
Online Help Videos	906
Home Designer Web Site	906
Home Talk Online User Forum	906
Technical Support	906
Upgrade to Chief Architect	907

Appendix B: Technical Support Services

Reference and Training Resources	909
Troubleshooting Common Technical Issues.....	910
Troubleshooting Printing Problems	911
Error Messages.....	913
Contacting Technical Support.....	914

Appendix C: What's New in Home Designer Pro 2014

Before You Begin.....	917
New and Improved Features by Chapter	923

Program Overview

Home Designer Pro is specifically designed for the residential and light commercial design professional. It allows you to easily and efficiently produce 3D models and construction documents for your projects. We thank you for choosing Home Designer Pro and wish you the best in your design work.

Chapter Contents

- Startup Options
- The Home Designer Pro Environment
- Toolbars
- Menus
- Dialogs
- The Status Bar
- Message Boxes
- Preferences and Default Settings
- Drawing a Plan
- Viewing Your Plan
- Getting Help
- About Home Designer Pro



Startup Options

 When Home Designer Pro opens, the **Startup Options** dialog displays, allowing you to choose how you want to begin working in the program or access useful resources.

The **Startup Options** dialog can be opened at any time by selecting **File> Startup Options** .



- 1 **Getting Started**- Click to launch your default internet browser to the Getting Started page on our web site, www.HomeDesignerSoftware.com. There, you will find links to a variety of online resources to help you begin using the program.
- 2 Select a **File** command to open a .plan or .layout file.

- Click **New Plan**  to open a new, blank plan. See “Creating a New Plan or Layout” on page 42.
- Choose **Open Plan/Layout**  to work on an existing plan or layout file. See “Opening and Importing Files” on page 48.

- 3 **Recent Files** lists the names of the most recently opened files. Click on a name to open the file.
- 4 Remove the check from **Show Options on Startup** if you do not want this dialog to display when you launch Home Designer Pro. Instead, a new blank plan the **Create New Plan** dialog opens.

To have the **Startup Options** dialog display at startup again, select **File> Startup**

Options  and place a check mark at **Show Options on Startup**.

- 5 The **Build** number of the program version you are using and the first five characters of your software license **Product Key** display here.

The Home Designer Pro Environment

Object-Based Design

Home Designer Pro's parametric, object-based design technology means you place and edit objects, rather than work with the many individual lines or surfaces used to represent them.

You can quickly select and edit the location, size, shape, style and other properties of objects as well as change the materials applied to their surfaces.

Use Home Designer Pro's editing capabilities to make the objects you place in a plan match the objects they represent in real life. For example, you can set up your windows and doors to match those available from your supplier.

3D Drafting

In Home Designer Pro, the entire drawing area is laid out on a Cartesian grid, a three dimensional coordinate system described using the X, Y and Z axes. The current position of your mouse pointer displays in the Status Bar at the bottom of the program window.

Architectural objects take up space in all three dimensions and their height, width and depth can be specified in Imperial or metric units. In addition, the location of objects can be precisely defined using coordinates, again specified in Imperial or metric units.

CAD objects such as lines and arcs take up space in two dimensions in the current view. Their dimensions can also be specified in Imperial or metric units and their locations precisely defined using coordinates.

Objects can be rotated relative to the Cartesian grid system, as well. When the program presents the option to rotate to an Absolute Angle, this angle will be measured relative to an imaginary horizontal line drawn in floor plan view from the origin in the positive X direction. See "Rotating Objects" on page 161.

Easy Access to Tools

You can access Home Designer Pro's features in various ways using the mouse and keyboard.

- Menus provide access to most tools.

- Convenient toolbar buttons allow fast access to tools and let you customize the interface.
- Keyboard shortcuts are available for most tools.
- Contextual menus display with a right-click of the mouse.
- The Status Bar at the bottom of the screen provides tool descriptions and other information about the current task.

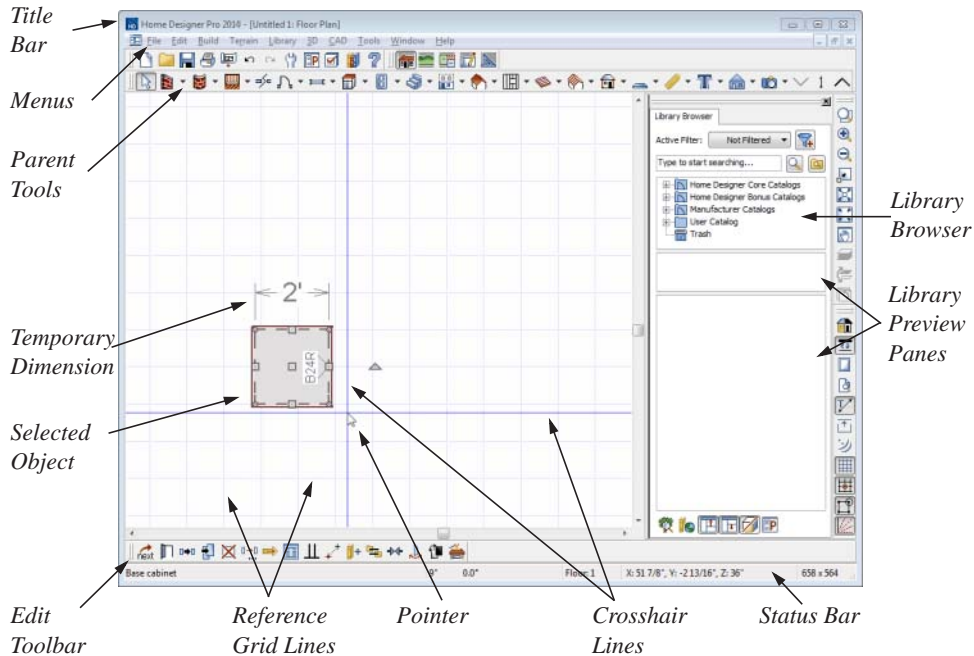

Using the Mouse

Many objects, such as doors and cabinets, are created by clicking the left mouse button. Others, such as walls, stairs and dimension lines, are created by dragging the pointer from one end of the object to the other.

 The **left button** is the primary button used in Home Designer Pro. Unless specified otherwise, Home Designer Pro documentation refers to the left mouse button.

Note: If you are left-handed and have re-programmed your mouse, reverse the instructions for left and right buttons in this manual.



The **Right button** has several uses. Right-click to select any object.

If, for example, the **Straight Exterior**

Wall  tool is active, the left mouse button allows you to select only walls. You can

select other object types such as cabinets with the right mouse button.

Use the right mouse button to temporarily switch to the Alternate edit behavior. See “Edit Behaviors” on page 120.

You can also use the right mouse button to open a context sensitive menu with additional editing commands.



The **Middle button** can be used to pan in floor plan view or to temporarily use the Move edit behavior.

You can also program it to work as a double-click.



The **Mouse Wheel** can be used to zoom in and out in most views.

The Back, or X1, button on a 5-button mouse can be used to temporarily enable the Concentric edit behavior. See the documentation for your mouse.

The Forward, or X2, button on a 5-button mouse can be used to temporarily enable the Resize edit behavior. See the documentation for your mouse.

Using the Edit Handles

When you select an object, its edit handles display. How each handle behaves when it is clicked and dragged may depend on which

Edit Behavior  is currently active. See “Edit Behaviors” on page 120.

When you pass the mouse over the edit handles, the pointer changes to show how you can use that handle.

- A two-headed arrow indicates that the object, corner or edge can be moved in the direction of the arrows.
- A four-headed arrow indicates that the selected object or edge may be moved in multiple directions.
- A circular arrow indicates that the selected object can be rotated.

Resize handles display along the edges of the object are used to change the size. See “Resizing Objects” on page 157.



The Move handle at the object’s center lets you move the object. See “Moving Objects” on page 152.

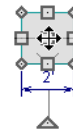

The triangular Rotate handle lets you rotate the object. See “Rotating Objects” on page 161.



You can cancel any edit handle operation before it is completed by pressing the Esc key on your keyboard or by pressing any two mouse buttons at the same time.

The edit handles that display depend on the type of object selected, the current view, and how far you are zoomed out.

Edit handles do not resize as you zoom in or out. If you are zoomed out far enough, some edit handles may be hidden so that they do

not stack over one another. As you zoom in, these handles become visible again.

Toolbars

Using the toolbar buttons is the fastest, easiest way to access many program features. You can move the toolbars, customize them by adding or removing buttons, or create your own toolbars from scratch. “Toolbar Customization Dialog” on page 93.

The toolbars that display in a given view depend on the view type. For example, toolbars that control camera position display in 3D views but not in floor plan view.

When you pass the pointer over a toolbar button, a “tool tip” displays the name of the tool. When you see one of these tool tips, press F1 to get more information about that item. A more detailed description displays in the Status Bar at the bottom of the window.

You can use either of two styles of toolbar interface: drop-down tools or parent-child buttons.

Drop-Down Tools

Click on the arrow to the right of a button to display a drop-down list of related tools. For example, click the arrow to the right of the

Window  button to display a drop-down list of the other Window Tools.

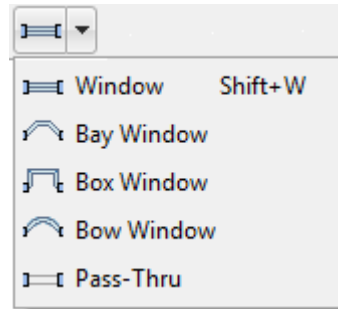

The most recently selected tool displays in the toolbar.

Parent and Child Tools

An alternative to the Drop-Down toolbar interface are Parent and Child tools. Parent toolbar buttons have a blue triangle in the lower right corner. When you select a parent button, child tools display on the right side of the toolbar.

When you click the **Window Tools**  parent button, for example, its child buttons display to the right.



You can select either Parent-Child or Drop-Down tools in the **Preferences** dialog. See “Appearance Panel” on page 61.

Toolbar Configurations

Toolbar configurations are sets of toolbars that are organized for certain tasks.

There are eight toolbar configurations in Home Designer Pro. Each can be accessed in the **Toolbar Customization** dialog by right-clicking on a toolbar button, or by clicking a button:



The **Default Configuration** displays a selection of architectural, file management and display settings tools.



The **Terrain Configuration** displays a selection of terrain, file management and display setting tools.



The **Space Planning Configuration** displays a selection of file management and display setting tools, as well as the **House Wizard** tools.



The **Plan Detailing Configuration** displays a selection of display settings, file management, annotation and other documentation tools.



The **CAD Configuration** displays a selection of CAD, file management and display setting tools.

Customizable Toolbars

Since the work you are doing determines the tools you need, Home Designer Pro allows you to tailor toolbars to suit your own needs. You can store various toolbar configurations for future use. For more information about customizing toolbars, see “Toolbar Customization Dialog” on page 93.

You can add toolbars to each configuration using the **Toolbar Customization** dialog while that configuration is active.

The Edit Toolbar

When you select an object, the edit toolbar appears. By default, it is located at the bottom of the program window, just above the Status Bar. The toolbar buttons that display can be used to edit the selected object(s). Which buttons display depends on the type of object selected, the current view, and how you selected the object.

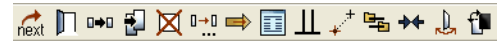

The edit toolbar buttons are the same as the options in the contextual menu when you right-click on an object.

Hotkeys

Many commands can be invoked from the keyboard. Press Alt on your keyboard and press the underlined letter in a menu name to access that menu, as well as items in the menus and submenus.

Other keys or key combinations will invoke a variety of program commands. If a Home Designer Pro menu item has a keyboard shortcut, or hotkey, associated with it, that hotkey will display to the right of its name in the menu.

Menus

Home Designer Pro uses a standard Windows menu format. The menus are located below the title bar in the program window and can be used to access nearly all tools in the program. Click on a menu name to expand it, then click on a menu item to either activate that tool or access the item's submenu. Items with a submenu have an arrow to the right of the name.

Menu items with an icon to their left have a toolbar button associated with them. Some buttons are not included on the toolbars but can easily be added. See "Toolbar Customization Dialog" on page 93.

The menu can be accessed using the keyboard. Press the Alt key once to enable this functionality - one letter in each menu will become underlined. Press the key associated with one of these underlined letters to expand its menu - one letter in each menu item's name will be underlined. Press the key associated with one of these letters to activate that tool or access the item's submenu. Press the Esc key to undo your last selection, or click with the mouse to exit out of this functionality.

Many tools in Home Designer Pro also have hotkeys associated with them. If a menu item has a hotkey, it will display to the right of the item's name. See "Hotkeys" on page 99.

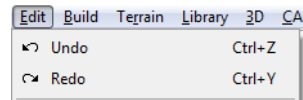

Edit menu items with button icons to the left and hotkeys to the right

In the Home Designer Pro documentation, menu paths are written in this format: **Build>**

Window> Box Window . An icon image after the menu path indicates that a toolbar button is also available.

Contextual Menus

Contextual menus are context sensitive menus that display tools relevant to a selected object or view.

To access contextual menus, right-click on an object, in an empty space in a view window or in a text field in any dialog box.

Contextual menus can be enabled or disabled in the **Preferences** dialog. See "Appearance Panel" on page 61.



Dialogs

Default and preference settings, object specifications, display settings, and many other functions are accessed through dialog boxes.

Dialog tabs and settings can be accessed using the mouse. You can also navigate the

settings on a given dialog tab using the keyboard:

- Press the Tab key proceed from one setting to the next, or Shift + Tab to go in the reverse direction.

- Line items in tree lists can be browsed using the arrow keys. Up and Down navigate the list, while Left and Right expand and contract categories.
- Settings with spin control arrows  can be adjusted by typing in the text field, using the up and down arrow keys, or the mouse scroll wheel.
- Settings with slider bars  can be adjusted by typing in the text field, using the left and right arrow keys, or the mouse scroll wheel.
- Press Enter on your keyboard to close any dialog and apply your changes.

Many dialogs have a preview that shows how the changes affect the object. This preview updates when you click in a different field or press the **Tab** key on your keyboard.

Some dialog boxes are resizable. Resizable dialogs have a size grip at the lower right corner of the box which you can click and drag.

Specification Dialogs



Each object in Home Designer Pro has a unique specification dialog where you can enter size, style and other information specific to the selected object. To access it, select the object and click the **Open Object** edit button. You can also

double-click on an object with the **Select Objects**  tool active to open its specification dialog. See “Selecting Objects” on page 124.

You can open the specification dialog for group-selected objects if they are of the same type, such as base cabinets.

- If a particular setting varies among the different objects, its check box will have a solid fill instead of a check mark. Click once to clear the box for all selected objects, or click a second time to place a checkmark for all selected objects.
- In some dialogs, if a particular setting varies among the different objects, it will have a “No Change” radio button. Leave this button selected, or choose a different option to apply it to all objects in the selection set.
- If the setting has a text field or drop-down list, it will say “No Change”. Changes made to such a setting can be undone by replacing the value in the text field with the letter N before you click OK.

If you select multiple objects of different types, the **Open Object**  edit button is usually not available. The button may display if the objects have data in common, but you can only edit the common data.

The Status Bar

The Status Bar at the bottom of the main program window displays information about the current state of the program.

This information depends on a variety of conditions such as settings in the **Preferences** dialog, the type of object selected, and the current position of the

pointer. The information may include the following:

- A brief description of the toolbar button or menu item highlighted by the mouse.
- A description of the selected object.
- The total number of objects currently group-selected.
- Basic information about a selected library object, folder, or catalog.
- The layer that the selected object is on.
- The current floor.
- The current CAD coordinates of the mouse pointer.
- The screen redraw time.
- The length and/or angle of an object as it is being drawn.

The number format used in the Status Bar is set in the **Dimension Defaults** dialog, while the angle style can be specified in the **Number Style/Angle Style** dialog. See “Format Tab” on page 722 and “Number Style/Angle Style Dialog” on page 89.

Message Boxes

As you work in Home Designer Pro, the program will alert you if you command it to do something that could potentially cause a problem, or if the program encounters a problem that needs your attention.

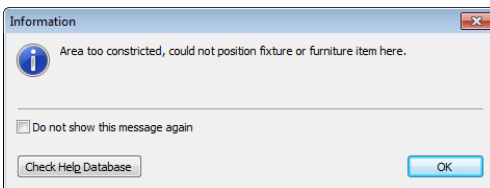

Situations where such message boxes may display include:

- Closing a file or view without saving;
- A file referenced outside the program, such as an image or texture, is missing;
- Creating an object in a space too small to contain it.

You can access the settings in a message box using the mouse, or navigate them using the keyboard:

- Press the Tab key proceed from one setting to the next, or Shift + Tab to go in the reverse direction.
- When a checkbox is the active setting, press the Spacebar to check or to clear it.
- Buttons have hotkeys associated with them. Press the Alt key on the keyboard to underline the hotkeys in the current message box.
- Press Enter on your keyboard to close the message box and perform the action associated with the highlighted button.

Some message boxes include a “Remember my choice” or a “Do not show this again” checkbox. Check this box to prevent messages of this specific type from displaying in the future.

To allow all message boxes to display again, click the **Reset Message Boxes** button in the **Preferences** dialog. See “Reset Options Panel” on page 89.

Preferences and Default Settings

Preferences and default settings control many aspects of the user interface and tool behavior in Home Designer Pro. You can use these settings to customize the program to suit your personal work style.

For more information about defaults and preferences, see “Preferences & Default Settings” on page 55.

Preferences

Preference settings let you change program behavior to suit your workflow. For example, you can:

- Turn certain display elements on or off.
- Choose background and editing feedback colors.
- Set frequency of autosaves, maximum number of “undos,” and file locking.
- Set default folders for various files.
- Control the editing behaviors of objects.
- Setup the materials list categories, sub-categories, and report style, as well as manufacturer and supplier information.
- Set rendering specifications to maximize efficiency and quality.

Preference settings are global, affecting all plan and layout files.

Defaults

Most objects in Home Designer Pro derive their initial properties from their respective default dialogs.

For example, a newly placed **Window**  gets its initial values from the **Window Defaults** dialog and a newly placed **Hinged**

Door  gets its initial values from the **Door Defaults** dialog.

Once an object is placed in a plan, its initial properties can be overridden, but setting up your defaults before you begin drawing can save you considerable time as you build a model in the program.

Default settings, unlike Preferences, are file specific.

Dynamic Defaults

Most default settings are static: if you change one, any objects of that type in the current file will not be affected. A few defaults, however, are dynamic: they are tied to existing objects in the drawing and if you change the default, those objects may be affected. See “Dynamic Defaults” on page 57.

Drawing a Plan

When you draw a plan in Home Designer Pro, you are placing 3D objects that represent building components. Home Designer Pro comes with predefined default

settings so you can start drawing plans immediately. You should review these default settings to be sure they match your

drawing and building methods. See “Preferences & Default Settings” on page 55.

Set the Defaults

1. Open a new plan using the template of your choice. See “Template Plans” on page 43.
2. Set the structural defaults:
 - Floor Defaults. Set the default ceiling height for Floor 1. See “Floor Defaults Dialog” on page 316.
 - Foundation Defaults. Set the foundation specifics such as type, footing size, and stem wall height. See “Foundation Defaults” on page 330.
 - Framing Defaults. Set the floor framing specifications, including type and dimensions. See “Framing Defaults” on page 436.
 - Default Wall Types. Specify the defaults for walls and railings. See “Wall, Railing, and Fencing Defaults” on page 176.
3. Set material defaults for roof, walls, and rooms (optional). See “Material Defaults” on page 650.
4. Set style defaults for doors, windows, molding, cabinets and other objects.

Draw the Floors

1. While the size of the drawing area in Home Designer Pro is limited only by the resources on your computer, it is best to begin your drawing near the origin, 0,0,0. See “3D Drafting” on page 25.

2. Draw the exterior walls on Floor 1. See “Drawing Walls” on page 189.
3. Adjust the perimeter shape and size as required. See “Using the Edit Handles” on page 197.
4. Place any first floor bearing walls.
5. Define types for special rooms such as garages and decks in the plan. See “Room Types” on page 234.
6. Place perimeter doors and windows. See “Doors” on page 253 and “Windows” on page 279.
7. Build additional floors. See “Adding Floors” on page 317.
8. Specify the default ceiling height for each floor as soon as it is created. See “Floor Defaults Dialog” on page 316.
9. Adjust the perimeter shape of additional floors as needed. See “Editing Walls” on page 197.
10. Align edited or moved walls with those above or below where appropriate. See “Aligning Walls” on page 201.

Entering Dimensions

When using Imperial units, enter distances as inches or feet and inches, in fractional or decimal form. Millimeters are the default unit for all metric distances. See “Dimensions” on page 719.

- To enter feet, include the (') marker or the program assumes inches.
- In most cases, the program allows precision to 1/16th of an inch. Fractions with denominators 2, 4, 8 and 16 are allowed.

- The program usually converts decimals to fractions.
- You can enter angles as decimal degrees, degrees, minutes, and seconds, quadrant bearings, or azimuth bearings. See “Number Style/Angle Style Dialog” on page 89.

Build the Foundation

1. Derive the foundation plan from the first floor. See “Building a Foundation” on page 334.
2. Adjust the foundation perimeter shape as needed.
3. Place interior foundation walls as needed for the first floor bearing walls.
4. Place any other foundation walls required.
5. **Align with Above** as needed. See “Aligning Walls” on page 201.

Add Structure and Details

1. Build non-structural interior walls. Begin on floor one and work up in multiple story structures.

2. Add walls where needed to create features such as chimney chases, plumbing walls, or Open Below areas.
3. Finish the relevant interior structure including interior doors, doorways, cabinets, fixtures, and fireplaces.
4. Build the roof planes. If you generate the roof automatically, remember to carry the roof directives in the walls from the first floor up to the top floor for multiple story structures. See “Roofs” on page 349.
5. Build the framing. See “Framing” on page 435.
6. Build the terrain and landscaping. See “Terrain” on page 537.
7. Create the plot plan. See “Plot Plans” on page 553.

Create the Layout

1. If one does not exist, create a Layout file with a title block, placing the border, title block, and other text on page 0. See “Layout” on page 863.
2. Send views to the layout. See “Sending Views to Layout” on page 866.
3. Print the plan. See “Printing & Plotting” on page 841.

Viewing Your Plan

You can see your model in a variety of different 2D and 3D views. You can display more than one view at a time; and in any view, you can pan or zoom in or out. See “Zoom & View Tools” on page 653.

Floor plan view is a 2D view of the model and is most commonly used for drawing and editing. In floor plan view, each floor displays separately and you can only edit one floor at a time; however, you have extensive control over which objects display at any given time,

can easily switch between floors, and can also display items on a second floor for reference.

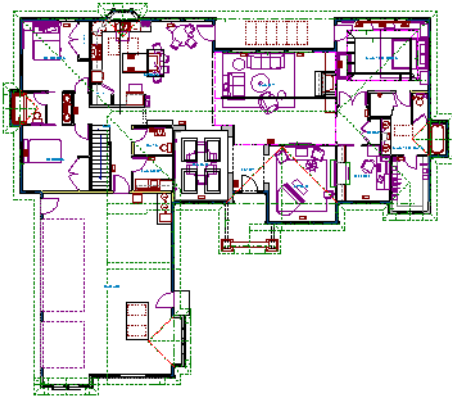

You can create interior and exterior 3D views of your model from any perspective. As in floor plan view, you can select and edit many objects in 3D views and control which objects are visible. See “3D Views” on page 663.



You can also create **Doll House Views** that show only the current floor plus any floors beneath it. Ceilings on the current floor are omitted so you can see the interior, visualize the relationships between spaces, and plan traffic flow.



Framing Overviews display framing in 3D, provided that framing has been built. You can customize 3D views to serve special purposes such as this.

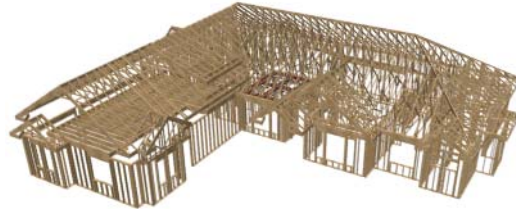

The Cross Section and Elevation camera tools create scaled 2D views of a model’s exterior and interior that can be dimensioned and annotated. Just as in other views, you can select and edit objects in a Cross Section/Elevation view as well as control which objects display.

Layout



All plan views can be sent to a layout where they can be arranged to produce construction documentation. See “Sending Views to Layout” on page 866.

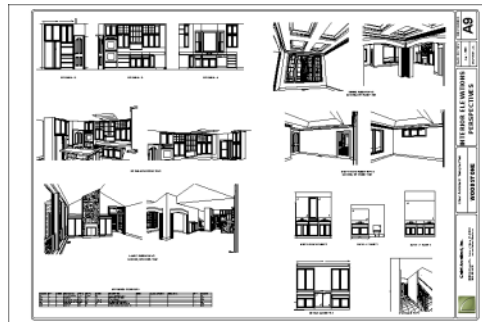

All views can also be exported as a graphic image. See “To export a picture” on page 811.

Getting Help



There are many forms of help available in Home Designer Pro including: Tool Tips, the Status Bar, and the online Help menu.

All these forms of help assume you have a basic working knowledge of the Windows® operating system, including how to use a mouse, open, close and save files, copy, paste, and right-click to access contextual menus. Help also assumes you are familiar with Windows® terminology.

More information is available in the product documentation in both printed and electronic format and on Home Designer's official web site, www.HomeDesignerSoftware.com. See "Additional Resources" on page 905.

Tool Tips

When you move the pointer over a toolbar button or menu item, a **Tool Tip** displays, offering a brief description of the tool. More information displays in the Status Bar at the bottom of the window.

Online Help Menu

Online **Help** is a searchable menu that provides information about all of the tools in

Home Designer Pro. Select **Help> Contents & Index**  to open the online Help and explore the table of contents, browse the Index, or search for keywords.

Current Mode Help

Online Help can also be used to provide instant information about toolbar buttons, menu items, and objects in your plan.

- When you move the cursor over a toolbar button or menu item, a brief summary of that tool displays in the Status Bar. Press the F1 key to open online Help to a page with more information about the tool.
- When an object is selected, edit handles display. Place the cursor over an edit handle and press **F1** to open online Help to a page with information about that handle.
- Press the **Help** button in any dialog box to open online Help to a page describing the options in that dialog.

Chief Architect strives to make our documentation as helpful as possible for all of our customers. Please send any questions, comments, or feedback to documentation@chiefarchitect.com.

About Home Designer Pro

Select **Help> About Home Designer Pro** to view information about your software license, the program's version number, and its release date.

Contact information for Chief Architect, Inc. is available on the **More Information** tab.

Upgrade to Chief Architect

Select **Help> Upgrade to Chief Architect** to launch your default web browser to the Chief Architect web page, www.chiefarchitect.com, where you can learn about this powerful home design software for building professionals.

Chief Architect can open plans originally created in Home Designer, and offers an extensive set of drawing, editing and rendering tools that allows you to produce complete, professional working drawings.

File Management

Home Designer Pro reads and edits two main document types: **.plan** files and **.layout** files. The complete 3D model of a structure, surrounding terrain and any CAD data associated with it are stored in the plan file. Data used to create working drawings and the links to various views are stored in the layout file.

All commands related to opening, saving and closing plans are located in the File menu. You can also open plans from the **Startup Options** dialog. See “Startup Options” on page 24.

Just as with files created in other software applications, you should back up your plan and layout files externally on a regular basis to avoid accidental loss of work.

Chapter Contents

- Compatibility with Other Programs
- Organizing Your Files
- Home Designer Pro Data
- Creating a New Plan or Layout
- Saving, Exporting, and Backing Up Files
- Thumbnail Images
- Auto Archive
- Undo Files
- Opening and Importing Files
- Searching for Plans
- Backup Entire Plan
- Closing Views and Files
- Exiting Home Designer Pro

Compatibility with Other Programs

Plans and layout files produced in the following programs can all be read by Home Designer Pro 2014.

- Chief Architect® X1 through X4 (limited editability if enabled)
- Chief Architect® 5.0 through 10.08 (read only)
- 3D Home Architect® 3.0 and 4.0
- Chief Architect® Home Edition 5.0
- All Better Homes and Gardens Home Designer® products, Interior Designer, and Landscaping and Deck Designer, Versions 6 through 8.
- All Chief Architect Home Designer® products, Interior Designer, and Landscaping and Deck Designer, Versions 9 through 2014.
- Trading Spaces® Design Companion™

Note: 3D Home Architect 5.0 was not developed by Chief Architect, Inc. Plans written using 3D Home Architect 5.0 or later cannot be read by Home Designer Pro.

Only the **.PL1**, **.LA1**, **.plan**, and **.layout** files from prior versions can be opened in Home Designer Pro 2014.

Files that have been opened and saved in Home Designer Pro 2014 cannot be read by any of the program versions listed above. To continue to read files in the program in which they were created, be sure to create copies of your files before opening them in Home Designer Pro 2014.

Plans created in Chief Architect, build 11.4 and later, can be opened in Home Designer programs for viewing and annotating only. Limited editability in Home Designer programs is an option that can be enabled when the file is opened in Chief Architect.

Several steps are required to successfully convert plans created in an earlier program version to the Home Designer Pro 2014 format. Before doing so, see “Before You Begin” on page 917.

Organizing Your Files

You should keep your plan and layout files separate from the support files needed to run Home Designer Pro. To keep files organized, you may find it helpful to create a new folder for each project.

Home Designer Pro files may use imported images, textures and other custom content saved in their own external data files.

Consider storing copies of all external files in the same folder as the plan and layout files that use them so that they are easily found.

Here is one way to organize your files:

- Create a folder in your Documents directory (“My Documents” in Windows XP) called “Home Designer Pro Plans” or

another name you prefer. See Microsoft Windows Help to learn how to create folders.

- Inside this folder, make a new folder for each client or project. Save all the files for that client or project inside this folder, including plan and layout files and referenced external files. See “Saving, Exporting, and Backing Up Files” on page 43.

Bear in mind, though, that path names exceeding 260 characters cannot be opened by Home Designer Pro. As a result, it is a good idea to limit the number of embedded folders you use in your file organization method.

Once you understand the file management of Home Designer Pro, you should decide on a naming convention that suits your needs.



It is recommended that each layout file be saved in the same folder as the plan file(s) associated with it. See “Managing Layout Links” on page 873.

To specify a default Save As location

1. Select **Edit> Preferences** , then select New Plans from Category list. See “New Plans Panel” on page 71.
2. Under Open and Save As, click **Use this Folder**. The **Browse** button becomes available.
3. Browse to the folder you plan to save your projects in. Click **OK**.

Home Designer Pro Data

When Home Designer Pro 2014 is installed, the program automatically creates a folder in the user Documents directory called **Home Designer Pro 2014 Data**. This folder contains important user-specific information saved in the following folders and files and should not be moved, renamed or deleted:

- **Archives** - A folder of automatically archived plan and layout files. See “Auto Archive” on page 46.
- **Backdrops** - A folder of custom backdrop images. See “3D Backdrops” on page 679.
- **Images** - A folder of custom images. See “Adding Materials and Images” on page 614.
- **Database Libraries** - A folder of user library data. See “Library Content” on page 609.
- **Scripts** - A folder for custom Ruby scripts associated with Chief Architect plans.
- **Templates** - A folder of plan and layout template files. See “Creating a New Plan or Layout” on page 42.
- **Textures** - A folder where you can save image files used to create custom material textures. See “Creating Materials” on page 637.
- **Toolbars** - A folder of customized toolbar files. See “Toolbar Customization Dialog” on page 93.

- **mmaster.mat** - The Master Materials List file. See “The Master List” on page 899.
- **units.dat** - A list of user-created units of measurement. See “Unit Conversions Panel” on page 71.

The name of the Home Designer Pro 2014 Data folder cannot be changed, but you can specify its location on your computer in the

Preferences  dialog. It’s best to use a location on your local hard drive. See “Folders Panel” on page 69.

Just as with your plan and layout files, it is a good idea to back up your Home Designer Pro 2014 Data folder.



If the Home Designer Pro 2014 Data folder is renamed, moved or deleted, the program will automatically replace it using default information from the Home Designer Pro installation folder. When this occurs, customized user settings and custom user library content will not be available.

Because the Home Designer Pro 2014 Data contains custom user data, it is not deleted when the program is uninstalled. See “Uninstalling Home Designer Pro” on page 23 of the User’s Guide.

Creating a New Plan or Layout



To open the **Create New Plan** dialog, select **File> New Plan**.

You can also choose **New Plan** in the **Startup Options** dialog. See “Startup Options” on page 24.



Create a new layout file by selecting **File> New Layout** or by sending a view to layout when no layout file is yet open or associated with the current plan file. See “Creating a Layout File” on page 865.

By default, a new layout file will be assigned the same name of the first plan file sent to it, associating the layout files with the plan files used.

Note: Only one layout file can be open at any given time.

New, blank plans are called **Untitled.plan** and new, blank layout files, **Untitled.layout**.

Unless these files are named and saved, they will be lost when closed. See “Saving, Exporting, and Backing Up Files” on page 43.

Units of Measurement

All plan and layout files save measurements in either Imperial or metric units. New files are created using one or the other, depending

on the current setting in the **Preferences**  dialog. When the program is first installed, the Windows OS setting for units determines what system is used. See “New Plans Panel” on page 71.

A plan or layout file’s unit of measurement must be specified before it is created and cannot be changed later.

While it is recommended that you create new plans using the type of unit that you plan to use, you can display dimensions using any

type of unit. See “Dimension Preferences and Defaults” on page 719.

Template Plans



When you select **File> New Plan** in Home Designer Pro, the **Create New**

Plan dialog opens, letting you select a template for your new plan. The resulting new plan uses either metric or Imperial units of measurement and predefined default settings, layer settings, wall definitions, and page setup information.

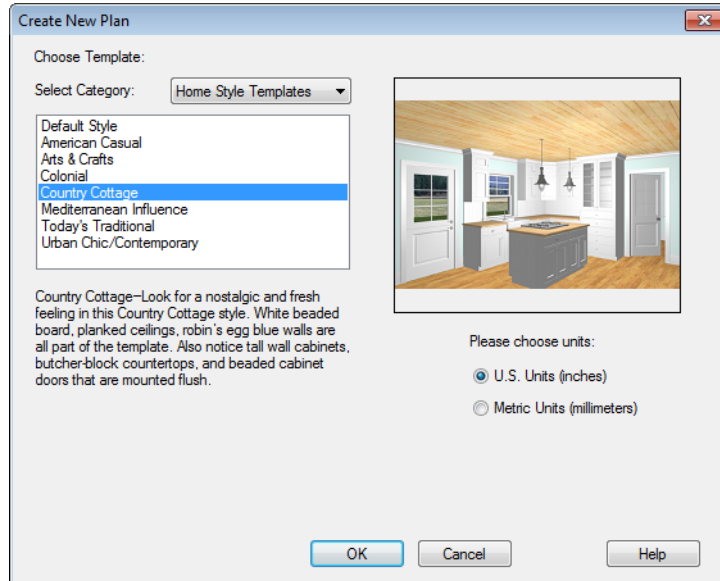

Home Designer Pro includes a selection of plan templates, each with different default settings that allow you to begin working in a particular plan style quickly. See “Default Settings” on page 56.

Choose a category from the drop-down list, then select a style template from the scrollable list beneath it. If you are uncertain

as to the right style for your plan, choose Default, as you cannot change the plan style template once a plan has been created.

Select either **U.S. Units** or **Metric Units** of measurement, and click **OK**. The floor plan view window opens, ready for you to begin drawing.



Saving, Exporting, and Backing Up Files

Saving, exporting, and backing up your files are three separate tasks that accomplish

different things:



- Saving a plan or layout file retains your work so that it can be later opened in Home Designer Pro.
- Exporting a file allows you to save certain kinds of data in a format that can be used by a program other than Home Designer Pro.
- Backing up your files involves taking steps to make sure that your valuable data is protected and available when needed.

Saving Plan and Layout Files

  When you first save a new, untitled file, you must select a location for it on your computer and give it a name. There are two options for saving plan and layout files: **File> Save** and **File> Save As**.

By default, a new layout file is assigned the same name as the first plan file from which a view is sent to it. It is also saved in the same directory as the plan file. If no view has been sent to a layout, it remains untitled until you save it.

 Although the program warns you if you try to exit without saving, you should get in the habit of saving plan files before exiting the program.

Both **Save**  and **Save As**  can be used to save your plan and layout files; however, they accomplish this in two different ways.

- **File> Save**  saves the current state of your plan or layout file without changing its name and should normally be used for saving your work.

- **File> Save As**  opens the **Save Plan File** dialog, allowing you to save the plan or layout file using a different name or location on your computer.

To save an untitled plan or layout file

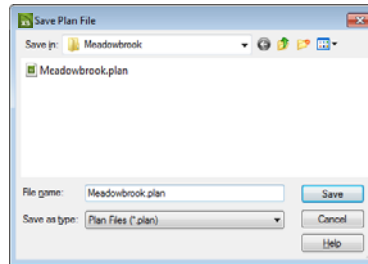

1. Select **File> Save**  to open the **Save Plan File** dialog.







2. In the **Save in** drop-down, browse to the location on your computer where you would like to save the file. See “Organizing Your Files” on page 40.
3. In the **File name** text field, type a name for the file.
4. Home Designer Pro automatically assigns the **File of type** and file extension **.plan** to plan files and **.layout** to layout files.
5. When both the Save in location and File name are correct, click **Save**.

Any previously saved cross section/elevation views associated with the plan are also saved with this command.

When saving a layout, the program saves all the links to the various views saved in the layout, and all the CAD objects added to the **.layout** file.

Initially, all **Open**  and **Save As**  operations go to the “My Documents” folder of your computer. After that, the location last visited is remembered and subsequent

Open  or **Save As**  commands default to the directory last used for that operation. This path is saved when the program exits. The next time Home Designer Pro is launched, these defaults are used.

If you prefer, you can instead specify a directory to be used for all **Open**  or **Save As**  operations in the **Preferences**  dialog. See “New Plans Panel” on page 71.

Exporting Files

Home Designer Pro has a number of options for exporting and importing information out of and your drawings. Often, file export dialogs are nearly identical to the **Save Plan File** dialog. See “Importing & Exporting” on page 827.

Similarly, file import dialogs are often similar to the **Open Plan File** dialog. See “Importing Files” on page 49.

Revision Files



Revisions are a common aspect of any design project. There are a number of possible strategies for organizing revision files:

- Prepending the file name;
- Appending the file name;
- Saving revisions in separate folders.

To avoid confusion and potential mistakes, it is recommended that you always give files unique names - including revision files. If you choose to organize your revisions by

saving them in separate folders, you should also give each file a unique name that makes it impossible to confuse it with another file saved in a different folder.

Backup Entire Plan

File > Save As  is a simple way to transfer a plan or layout to a different location on your computer. Bear in mind, though, that plan and layout files often reference external data files such as imported textures, images, and backdrops. These external files are not affected when **Save As**  is used.

If you transfer a plan file from one computer to another, the program will warn you of missing files if the external data files used by the plan cannot be found when you open it.

Layouts are also dynamically linked to plan files. When transferring layout files to another computer, be aware that the plan files are also external file references and are not actually contained in the layout.

When transferring plans or layouts to another computer that does not have these external files, use the **Backup Entire Plan**  tool. See “Backup Entire Plan” on page 52.

Backing Up Your Files

 It is always a good idea to create backup copies of all your important files on your computer.

It is strongly recommended, however, that you never save directly:

- Across a network, such as onto a server;
- Onto removable media such as a USB thumb drive, CD, or DVD;

- Across the Internet.

Instead, copy your files to such locations in Windows Explorer only after you have saved them on your computer's hard drive and exited the program.

Similarly, you should never open files saved in these locations. Copy the files to the local hard drive, and then open them. See "Opening and Importing Files" on page 48.

Archive folders are used by Home Designer Pro to manage prior versions of your files. You should not view these files as a substitute for your own backup routine, and

should never save a file in an archive folder. See "Auto Archive" on page 46.

When backing up your Home Designer Pro files, consider backing up not only your **.plan** and **.layout** files, but your custom user data, as well - including library content, toolbar configurations, and textures. This custom data is all located in the Home Designer Pro Data folder, so it can be easily backed up. See "Home Designer Pro Data" on page 41.

You can, if you wish, create a folder inside the Data folder for your **.plan** and **.layout** files, as well. See "Organizing Your Files" on page 40.

Thumbnail Images

A thumbnail is a miniature image that helps identify a file in the **Open Plan File** dialog and in the **Find Plan Wizard**. Any view of a plan or any layout page can be saved as the thumbnail. See "Searching for Plans" on page 50.

If thumbnails are enabled in the

Preferences  dialog, the program automatically creates one when you first save a new plan or layout. You can choose to generate small or large thumbnails. See "File Management Panel" on page 68.

To create a custom thumbnail image

1. You must save the file and give it a name before you can save a thumbnail.
2. Create the 2D or 3D view that you want to use as a thumbnail for the current file.
3. With the desired view active, select **File> Save Plan Thumbnail** .

Thumbnails are saved using the same filename as the associated plan or layout file with the **_p.jpg** file extension for plans and **_l.jpg** for layouts. If a thumbnail already exists, the program asks if you want to overwrite the existing thumbnail.

Auto Archive

The first time a plan or layout is saved, Home Designer Pro creates an Archive

folder in the Home Designer Pro Data folder. The Archive folder contains Auto Save and Archive files.

The program does not create Auto Save and Archive files for untitled plans and layouts. In order for these to be created, a file must have been previously saved and given a name and save location on your computer. Further, Archive files are only updated when you save your work.

Auto Save and Archive files should not be viewed as a substitute for regularly saving your work by selecting **File> Save**  or pressing Ctrl + S on the keyboard, nor should they be considered an alternative to your own file backup routine.

Archive Files

Every time a drawing is saved, Archive files that keep a historical archive of your plan are automatically created or updated.

 Regardless of what archiving option you select in the Preferences dialog, if you do not save your work regularly, your archive files will not be updated.

Plan, layout and related files from previous versions of the program are automatically moved to the archive folder when the plan is opened and saved in Home Designer Pro.

Archive files are meant to be for emergency use only. If you must access an archive file, open it as you would any other file. See “Creating a New Plan or Layout” on page 42.

As soon as the file is open, use **Save As**  to save this file to another location.

Auto Save Files

As you work, Home Designer Pro automatically creates Auto Save files at regular intervals when changes are made to a file but not saved by selecting **File>**

Save .

These Auto Save files are appended **_auto_save.plan** or **_auto_save.layout** and are saved in the Archive folder.

When you close a file normally, its Auto Save file is retained until the next time the file is opened - at which time the Auto Save file is overwritten.

 JonesResidence_auto_save.plan

Auto Save file after normal shut-down

You can enable Auto Save and set its frequency in the **Preferences**  dialog. See “General Panel” on page 67.

Auto save files created as a result of an improper program shutdown are appended **_auto_save_bak.plan** or **_auto_save_bak.layout**.

 JonesResidence_auto_save_bak.plan

Auto Save file after abnormal shut-down

If your computer shuts down accidentally, you can recover some of your work by opening the **_auto_save_bak** file.



 A file is auto saved only if you have saved it previously. Auto Save does not work for unnamed files.

When you reopen a file after a computer shut down or system crash, the following dialog

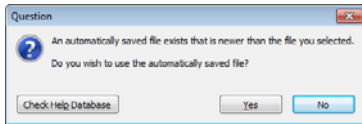

displays if an Auto Save file newer than the original file is found.



Even with Auto Save, you should save your work manually on a regular basis using any of the following methods:

- Click the **Save**  button.
- Select **File> Save** .
- Press Ctrl + S on the keyboard.

Undo Files

Home Designer Pro stores a set number of copies of all open plan file changes, known as undo files. Undo files are referenced whenever you select **Edit> Undo**  or **Edit> Redo** . See “Undo and Redo” on page 173.

Undo files are stored in the Undo Directory, which can be specified in the **Preferences**  dialog. See “Folders Panel” on page 69.

By default, the Undo Directory is the Windows Temporary Directory. When you

use Windows system cleanup features, these files can be deleted. Because of this, you should only use these type of utilities when Home Designer Pro is not running.

The maximum number of Undo files is specified in the **Maximum Undos** value in the Preference settings. If you have **Undo** enabled, be sure to define a directory on a hard drive with enough space for these files.

When Home Designer Pro is closed normally, any current Undo files are deleted.

Opening and Importing Files

Opening and importing files are often similar tasks, but accomplish two very different things:

- Opening a file refers to opening it in the program in which it was created. Only plan or layout files can be opened in Home Designer Pro. See “Compatibility with Other Programs” on page 40.
- Importing a file brings data that was created in a different program into Home Designer Pro. A number of different file

types can be imported into Home Designer Pro.



Select **File> Open Plan** to open an existing **.plan** file or **File> Open Layout** to open an existing **.layout** file located on your computer. Home Designer Pro automatically browses to either the directory last used or to a specific directory, depending on your current Preferences  settings. See “New Plans Panel” on page 71.

 Never open a file located on a server or other computer on a network, or on a removable storage device. Copy such files to your local machine's hard drive first, and then open the copy.

The **Open Plan File** and **Open Layout File** dialogs can be resized by clicking and dragging the lower right corner.

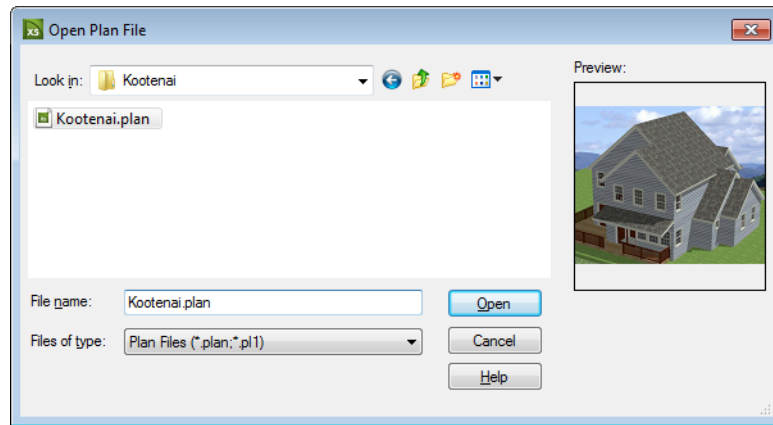

- In the **Look in** drop-down, browse to the location on your computer where the file you wish to open is saved.
- Any folders and either **.plan** or **.layout** files in the current location display in the field below. The file type that displays depends on the Files of Type selection.
- Click on the file you wish to open. Its name will display in the **File name** text field.
- If a preview image of the file is available, it will display on the right side of the dialog. See “Thumbnail Images” on page 46.
- The only file types available in the **Files of type** list are **.plan** and **.layout**.
- When the desired file is selected, click **Open**.

Plan files open to the floor that was active when the file was last saved and closed; layout files open to the page that was active.

Importing Files

Home Designer Pro has a number of options for exporting and importing information out of and into your drawings. Often, file import dialogs are nearly identical to the **Open Plan File** dialog. See “Importing & Exporting” on page 827.

Similarly, file export dialogs are often similar to the **Save Plan File** dialog. See “Exporting Files” on page 45.

Recently Opened Files

The names of the plan and layout files you most recently opened or saved display at the bottom of the **File** menu. Click on a recent

file to open that file without using the **Open Plan File** dialog.

The maximum number of recent files listed in the **File** menu can be changed in the

Preferences  dialog. See “File Management Panel” on page 68.

The names of recently open files also display in the **Startup Options** dialog. Click on the name of a file to open it. See “Startup Options” on page 24.

Searching for Plans



Select **Tools> Plan Database> Search for Plans** to locate an existing, fully-editable sample plan or search a selection of non-editable plans by popular

home designers. This command opens the **Find Plan Wizard**, which helps you search for plans based on parameters that you define.

Find Plan Wizard

The **Find Plan Wizard** can be used to search for plans using stored information about each

plan, such as the style of construction and the number of bedrooms and other room types.

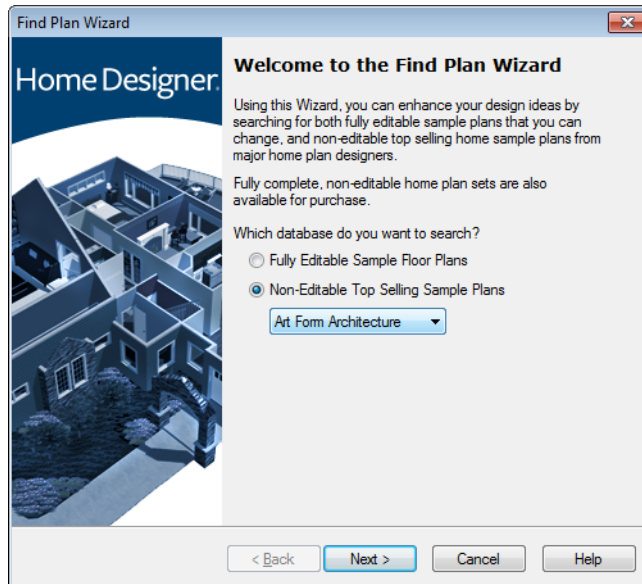

Begin by selecting either a database of editable sample plans or a collection of house

plan drawings by popular home plan companies, then click **Next** to continue.

House Style

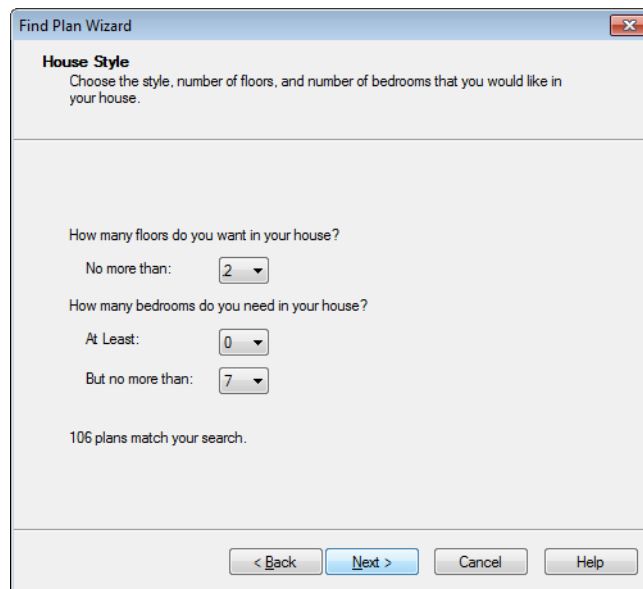

The screenshot shows a window titled "Find Plan Wizard" with a close button in the top right corner. The main heading is "House Style" with a sub-instruction: "Choose the style, number of floors, and number of bedrooms that you would like in your house." Below this, there are two questions with dropdown menus: "How many floors do you want in your house?" with a dropdown set to "2", and "How many bedrooms do you need in your house?" with two dropdowns: "At Least:" set to "0" and "But no more than:" set to "7". At the bottom of the window, it says "106 plans match your search." and there are four buttons: "< Back", "Next >" (highlighted in blue), "Cancel", and "Help".

At the bottom of each page, the number of plans that match your current search parameters displays. As you modify the parameters, this number increases or decreases as matching plans are found.

On any page, click the **Back** button to modify any previously selected parameters.

Select the style of house desired, the number of floors in the house, and the number of bedrooms, then click **Next** to continue.

House Size

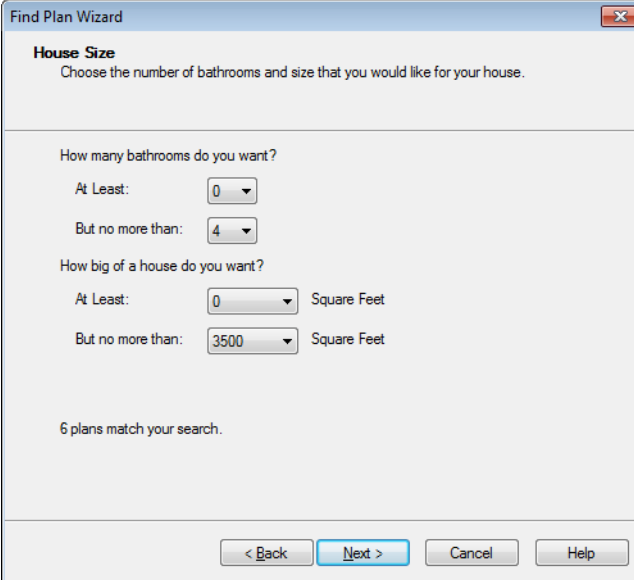

The screenshot shows a dialog box titled "Find Plan Wizard" with a close button in the top right corner. The main heading is "House Size" and the instruction is "Choose the number of bathrooms and size that you would like for your house." Below this, there are two sections of input fields. The first section is "How many bathrooms do you want?" with "At Least:" set to 0 and "But no more than:" set to 4. The second section is "How big of a house do you want?" with "At Least:" set to 0 and "But no more than:" set to 3500, both followed by "Square Feet". At the bottom of the dialog, it says "6 plans match your search." and there are four buttons: "< Back", "Next >" (highlighted in blue), "Cancel", and "Help".

Select the number of bathrooms and square footage of the house, then click **Next** to continue.

Plan Details

Click on the name of a plan in the list to see a preview of the plan

Click **Next**, then click the **Finish** button to open the selected plan.

Backup Entire Plan



Because Home Designer Pro plans and layouts often contain many references to other external files, it is necessary to copy all the associated files to a new location when a plan or layout is moved. You can do this easily by selecting **File> Backup Entire Plan**.

Backing up an Entire Plan is important when:

- Migrating legacy files created in older program versions.
- Transferring files to another computer or sending them to another user.
- Archiving or backing up your work.

To back up a plan or layout

1. To copy all associated plan or layout files to a new directory, select **File>**

Backup Entire Plan . The **Backup Entire Plan** dialog opens for you to choose what files are copied.

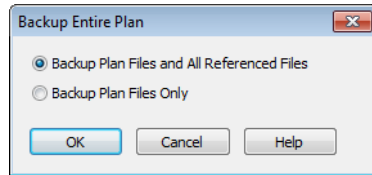

- Choose **Backup All Files** to copy all plan or layout files and all externally referenced files such as linked plan files, inserted picture files, metafiles, and texture, image, and backdrop graphics files.
 - Choose **Backup Plan Files Only** to copy all associated plan files and any externally linked files and inserted picture files, but no graphics or texture files. This is best used only when transferring a file to a computer that already has the graphics files installed.
2. When you click the **OK** button in the **Backup Entire Plan** dialog, the **Browse for Folder** dialog opens. Here you can

select the destination folder for the associated plan files.

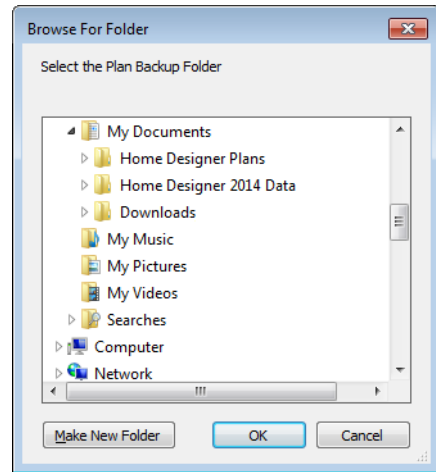

3. Navigate to any empty folder on your system and click on it to select it.
 - To create a new folder, click on a folder already present on your system, then click the **Make New Folder** button.
4. With the destination folder for the backup selected, click **OK**.

 You must select an empty folder for the Backup Entire Plan feature to work. If you select an existing folder that is not empty, the backup is cancelled.

Closing Views and Files

Choose **File> Close** to close the active window. If it is the last open view for a plan and you have not saved it, the program prompts you to save before closing. Edited cross section/elevation views also prompt you to save before closing.

Select **File> Close All** to close all currently open windows.

 Although the program warns you if you try to exit without saving, you should get in the habit of saving plan files before exiting.

Exiting Home Designer Pro

Select **File> Exit** to exit the program. If you have not saved any open plans, you are reminded to do so. It is better to save your work before exiting than to save on exit.

When you exit from the program using **File> Exit**, all Autosave files and Undo files are automatically deleted.

Preferences & Default Settings

Preferences are global settings that affect the functionality and appearance of the Home Designer Pro environment, while default settings control what objects look like when they are initially created. You can save time and increase your productivity by becoming familiar with these settings and customizing them before you begin a new project or as needed thereafter.

Chapter Contents

- Default Settings vs Preferences
- Dynamic Defaults
- General Plan Defaults Dialog
- Reset to Defaults
- Preferences Dialog
- Number Style/Angle Style Dialog

Default Settings vs Preferences

Default and preference settings have important effects on how the tools in Home Designer Pro function. Default settings are file specific, while Preferences are global, taking effect regardless of what file is open.

Defaults and Preference settings can be customized to suit your needs and improve your efficiency, so it is recommended that you become familiar with them and learn how you can use them to your advantage.

Default Settings



Default settings determine the initial characteristics of objects when they are first drawn. For example, when you place a base cabinet in a plan, its size, materials, front items, hardware are determined by settings in the **Base Cabinet Defaults** dialog.

Some defaults affect the structure of your model: for example, Floor, Foundation, Framing, and Wall defaults.

Defaults are file-specific, which means that any changes that you make to the default settings in one plan or layout file will have no effect on other plans or layout files.

You can access a complete list of the various default settings by selecting **Edit > Default Settings**  from the menu.

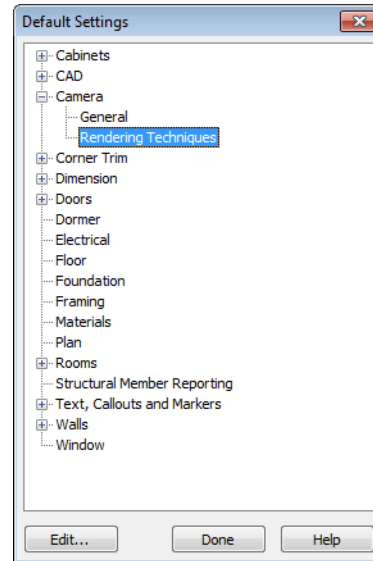

- Click the + beside a category to expand it and access the defaults for items related to that category.
- To open the defaults dialog associated with an item in the list, double-click on the line item, or click on the item and then click the **Edit** button.
- General CAD defaults are view-specific and are only available in views where CAD objects can be drawn. See “CAD Defaults Dialog” on page 770.

Many defaults dialogs can also be opened by double-clicking on a parent and/or child toolbar button of a tool affected by the settings in that dialog. For example, you can:

- Double-click the **Cabinet Tools**  parent button to open the **Defaults Settings** dialog for Cabinet tools only;

- Double-click the **Base Cabinet**  child button to open the **Base Cabinet Defaults** dialog.

Preferences

 Preference settings influence the overall environment of the program, such as what the interface looks like, how the tools are accessed, and the basic rules governing how objects are drawn and edited. See “Preferences Dialog” on page 60.

Unlike default settings, preferences are global, which means that any changes that you make to them will take effect in all plan and layout files.

To access the **Preferences** dialog, select **Edit> Preferences**  from the menu.

Region and Language Settings

There are a few formatting considerations in Home Designer Pro that are set based on your Windows® operating system’s Region and Language Format:

- **Units of measurement** - When you first install and launch the program, your template plan and layout files will be set to use either Imperial or metric units, depending on your Windows settings. See “New Plans Panel” on page 71.
- **Decimal mark format** - Depending on your Windows settings, either a period or a comma will be used in dimension lines, dialogs, and anywhere the program can display a numeric value using decimals.
- **Currency** - The currency associated with your Region and Language Format will be used in the Materials List, **Components** dialogs, and Loan Calculator. See “Materials Lists” on page 887 and “Loan Calculator” on page 802.

Dynamic Defaults

Dynamic defaults are values that can be changed globally throughout a model.

- If you change a dynamic default value in a defaults dialog, all objects of that type that are set to use the default will update automatically to use the new value.
- Any objects of that type that are not using the default value because of editing will not be affected if you change the default.

Dynamic defaults are found in the default dialogs of a variety of objects, including dimension lines, walls, doors, cabinets and rooms.

Materials are another example of an attribute that uses Dynamic Defaults. See “Material Defaults” on page 650.

In object specification dialogs, dynamic defaults are followed by either a (D) in the value field or a Default check box.

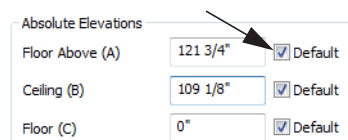

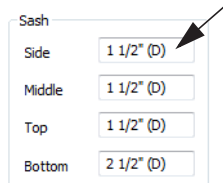



To edit a dynamic default, delete the (D) or remove the check from **Default** box and type the desired value.

To reset a value back to the dynamic default, type the letter D in the field or click the Default checkbox.

General Plan Defaults Dialog

The settings in the **General Plan Defaults** dialog control basic features of the Home Designer Pro environment. To open this dialog, select **Edit**> **Default Settings** .

select **Plan**, and click the **Edit** button, or double-click the **Select Objects**  button.

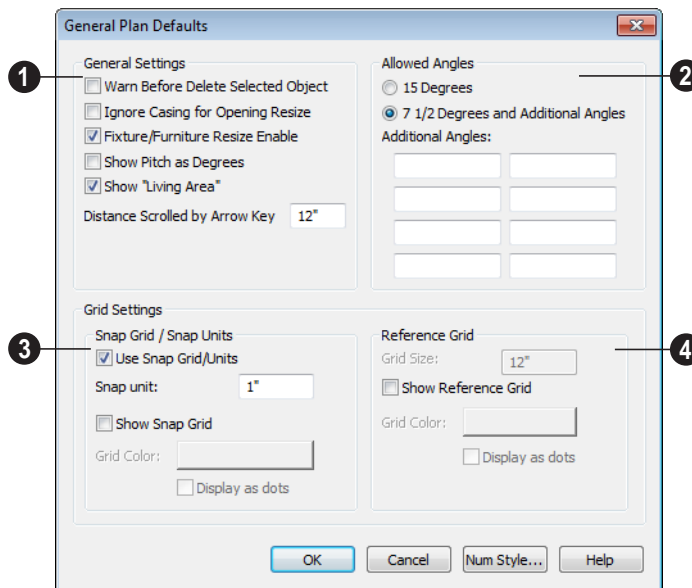

1 **General Settings** - Specify the default functionality for a variety of general behaviors in the program.

- Check **Warn Before Delete Selected Item** if you want the program to require confirmation before an item is deleted.

- Check **Ignore Casing for Opening Resize** to allow wall openings such as doors to be positioned against an intersecting wall. Clear this box retain sufficient space for the opening's specified trim width.

- Check **Fixture/Furniture Resize Enable** to allow the resizing of library symbols. When enabled, fixtures and furniture can be resized from 1 to 2000 inches (10 to 32760 mm).
- Check **Show Pitch as Degrees** to display the roof pitch in degrees.
- Home Designer Pro automatically calculates the square footage of each floor in the plan and shows this number as the living area in floor plan view. Uncheck **Show “Living Area”** to disable the display of the Living Area label. See “Living Area” on page 237.
- Enter the number of **Inches/MM Scrolled by Hotkeys** in floor plan view. See “Using the Arrow Keys” on page 655.

2 Specify the **Allowed Angles** used when Angle Snaps are enabled. See “Angle Snaps” on page 111.

- Select **15 Degrees** to enable Angle Snaps in 15° increments.
- Select **7 1/2 Degrees and additional angles** to enable Angle Snaps in 7 1/2° increments.

You can also enter up to eight **Additional Angles** in the fields provided. Click the **Number Style** button to specify the format used to enter angles. See “Number Style/Angle Style Dialog” on page 89.



3 The **Snap Grid** allows you to snap objects to specific points on-screen as they are moved or resized. See “Grid Snaps” on page 112.

- Check **Use Snap Grid/Units** to enable Grid Snaps.
- Specify the **Snap Unit** you wish to use.



It may be helpful to change the Snap Unit temporarily when working with large objects such as terrain or small objects such as molding profiles.

- Uncheck **Show Snap Grid** to turn off the display of the Snap Grid, a visual indicator of the location of the snap points.
 - Click the **Color** bar to specify the **Snap Grid Color**. See “Color Chooser Dialog” on page 651.
 - Check **Display as Dots** to display the Snap Grid using dots rather than lines.
- 4** Specify the display of the **Reference Grid**.
- Specify the **Reference Grid Size**.
 - Check **Display as Dots** to display the Reference Grid using dots rather than lines.

You can also click **Grid Snaps**  toggle button to turn on/off grid snapping or click the **Display Reference Grid**  toggle button to turn on/off the grid display.

Reset to Defaults

Select **Edit> Reset to Defaults** to open the **Reset to Defaults** dialog.

This dialog allows you to clear the special settings you have made in various parts of your plan.

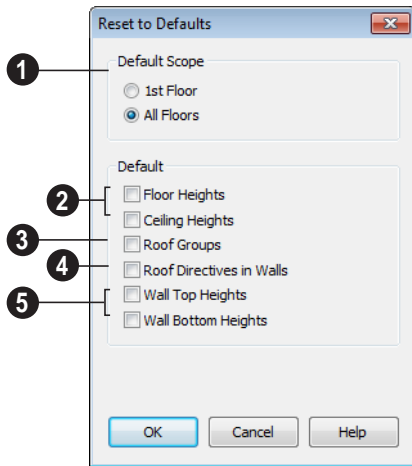

- 1 The settings can be cleared for the **current floor** or for **All Floors**.
- 2 **Floor and Ceiling Heights** - Floor and ceiling heights for any room can be changed in the **Room Specification** dialog. Check to reset the default values as specified

in the **Floor Defaults** dialog. See “Floor Defaults Dialog” on page 316.

3 **Roof Groups** - You can designate a different roof group for a room in the **Room Specification** dialog. This builds the roof over this room and others in the same roof group independently from the roof built over other parts of the plan. Check to reset to the default roof group, zero. See “Roof Groups” on page 353.

4 **Roof Directives** - You can specify how the roof builds above an exterior wall in its **Wall Specification** dialog. When Roof Directives are reset, all items on the Roof tab are unchecked and any value, such as the roof pitch, is reset to the default. See “Roof Directives in Walls” on page 353.

5 **Wall Top Heights and Wall Bottom Heights** - Wall shape and height can be edited in 3D views. Check to reset wall shapes and heights. See “Editing Walls” on page 197.

Preferences Dialog

 The settings in the **Preferences** dialog are global: they apply to all plan and layout files and are preserved between sessions. To access this dialog, select **Edit> Preferences**.

The **Preferences** dialog consists of panels which are accessed by clicking on the names in the Category tree along the left side.

The category tree structure is similar to other Windows programs. A “+” next to a category indicates that it has subcategories. Click the “+” to make the subcategories visible; to hide them, click the “-.”

The program remembers which panel you last accessed and opens to that panel the next time you open the dialog.

Preference dialog panels:

- Appearance Panel
- Colors Panel
- Font Panel
- Library Browser Panel
- Text & Page Setup Panel
- General Panel
- File Management Panel
- Folders Panel
- New Plans Panel
- Unit Conversions Panel

- Architectural Panel
- CAD Panel
- Line Properties Panel
- Sun Angle Panel
- Edit Panel
- Behaviors Panel
- Snap Properties Panel
- Materials List Panel
- Report Style Panel
- Master List Panel
- Categories Panel
- Render Panel
- Video Card Status Panel
- Reset Options Panel

Appearance Panel

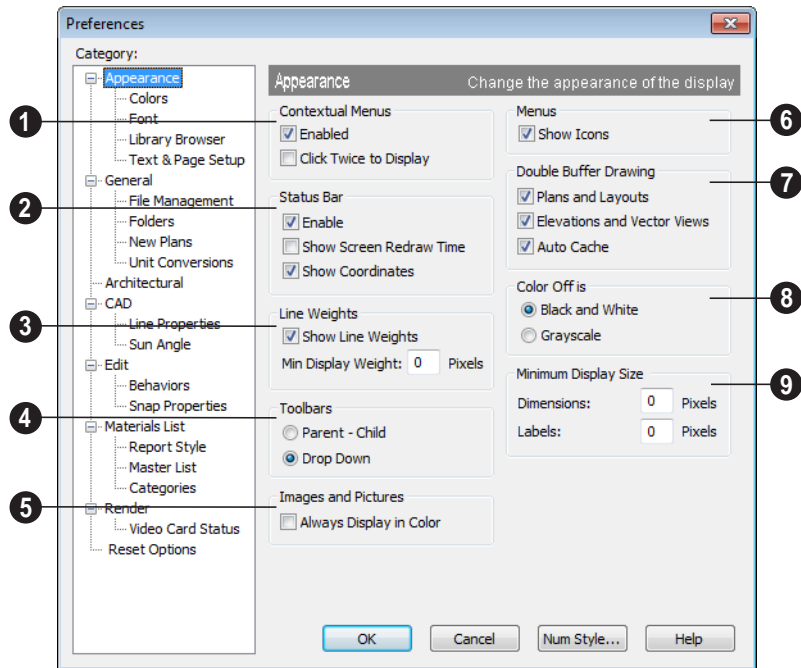

1 When **Contextual Menus** are enabled, you can right-click an object and a contextual menu displays with options that are unique to the selected object. The options

in a contextual menu are usually the same as those on the Edit toolbar.

A menu of general commands displays if you right-click in an empty space in a view window, away from any object.

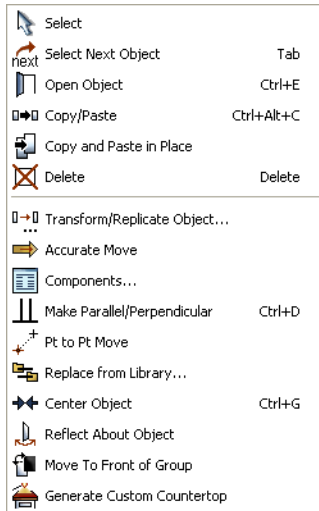

The contextual menu for a base cabinet

Since Home Designer Pro can use the right-click as a general select, you have the option to disable or limit the contextual menus.

- Check **Enabled** to activate contextual menus. Clear the check box to disable contextual menus.
- Check **Click Twice to Display** to require two right-clicks on an object before the contextual menu displays. This allows the first right-click to be a general select. See “Selecting Objects” on page 124.

In 3D views, the two clicks must be on the same object surface in order for the contextual menu to display: Clicking on two different surfaces of the same object is treated like two single-clicks.

- 2 The **Status Bar** at the bottom of the main window displays information about the current state of the program. See “The Status Bar” on page 31.

- Check **Enable** to activate the Status Bar or clear the check box to disable it.
- Check **Show Screen Redraw Time** to display the number of seconds it takes to redraw the screen. This is useful for determining the effectiveness of the 3D acceleration of your graphics card.
- Check **Show Coordinates** to display the coordinates of your cursor at all times on the right side of the Status Bar.

The number style for the coordinates is controlled in the **Number Style/Angle Style** dialog. See “Number Style/Angle Style Dialog” on page 89.

- 3 Check **Show Line Weights** to represent line weights on-screen. Because of monitor DPI, lines may appear to be much wider on screen than when they are printed. Zooming closer may reflect a more accurate idea of the actual line width.

Specify the **Min Display Weight**, the lowest line weight possible on screen, regardless of how far you zoom out. A Minimum Display Weight of 0 is the same as 1. This setting is ignored when printing or when **Print**

Preview  is enabled.

 The line weight for CAD objects may be defined individually through each object’s specification dialog or globally in the Layer Display Options dialog.

- 4 Specify how **Toolbars** present child tools when a parent button is clicked.
- Choose **Parent-Child** to display child tools as buttons at the end of the toolbar where the parent button resides.

- Choose **Drop Down** to display child tools when the drop-down arrow to the right of the parent button is clicked.

5 Images and Pictures - Check **Always Display in Color** to display images and pictures in color, even if color is turned off in a particular view. If you uncheck the box, pictures and images appear in grayscale when color is turned off.

6 Check **Show Icons** to display tool icons next to items in the menus.

7 Double Buffer Drawing - Double buffering means that all drawing is done to an offscreen bitmap and then copied to the screen. The result is that the screen does not flicker, but there may be a slight delay before individual objects appear on screen. This option does not affect Rendered views.

- Check **Plans and Layouts** to double-buffer in floor plan view and layouts.

- Check **Elevations and Vector Views** to double buffer in cross/section elevation and Vector views.

- Check **Auto Cache** to save a bitmap of the last screen draw. This bitmap is used to refresh the screen if no changes are made to the model. This option is not available on computers running Windows Vista.

8 Color Off is - Specify whether views appear in **Black and White** or **Grayscale** when color is toggled off. Does not apply to Rendered views. See “In Vector Views” on page 678.

9 Specify the **Minimum Display Size of Dimensions and Labels**, in pixels. This is the on-screen size and does not affect printed or exported output. To display dimensions and labels on-screen at the printed scale, set this value to 0 or turn on

Print Preview .

- Dimension sizes are set in the **Dimension Defaults** dialog. See “Dimension Defaults Dialog” on page 720.

Colors Panel

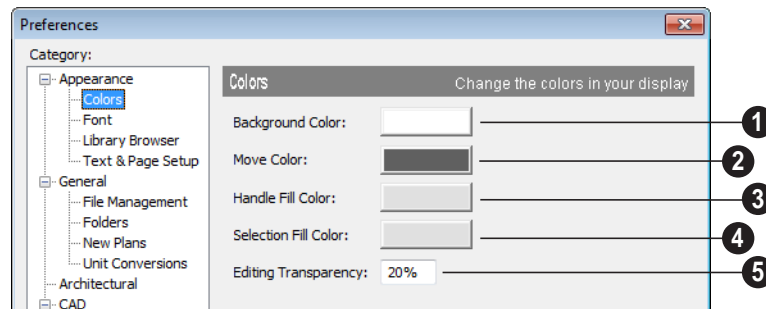

Click a color bar to open the **Color Chooser** dialog. See “Color Chooser Dialog” on page

651.

- 1 **Background Color** - Click the color bar to select the background color for all views except some 3D views. See “Rendering Techniques” on page 710.

The background color for 3D views that do not use the Vector View Rendering Technique or a backdrop image is set in the **3D View Defaults** dialog. See “Backdrop Tab” on page 671.

- 2 **Move Color** - Click the color bar to select the color of the lines that represent object(s) as they are being moved.

- 3 **Handle Fill Color** - Click the color bar to select the color for the edit handles for selected objects.

- 4 **Selection Fill Color** - Click the color bar to specify a color for selected objects. The color may change to ensure that selected objects are always visible, so this may not always be the color you expect.

 If the move color and the handle fill color are similar, it may be difficult to distinguish between active and inactive points. The colors should be sufficiently dissimilar to avoid confusion between active and inactive points.

- 5 Specify the **Editing Transparency**, which is the degree to which the selection fill and edit handles are transparent. The default value is 20%.

Font Panel

The Font panel controls the conversion of text in legacy plans when they are opened in

Home Designer Pro as well as the text used in the Materials List.

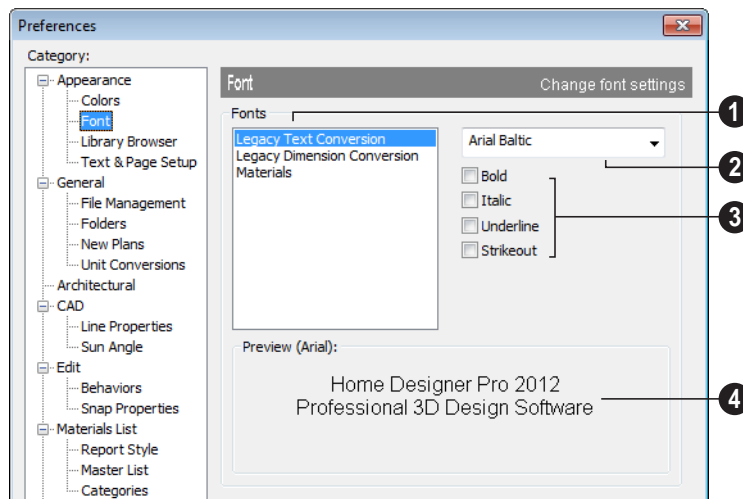

- 1 Choose Legacy Text Conversion, Legacy Dimension Conversion, or Materials to define the font for that use.

Legacy Text Conversion sets the default font for text created in previous versions of

Home Designer Pro. See “Character Size” on page 745.

Legacy Dimension Conversion sets the fonts for dimensions created in previous versions of Home Designer Pro. See “Dimensions” on page 719.

Materials sets the default font for the Materials List and Master List created in previous versions of Home Designer Pro. See “Materials Lists” on page 887.

 Legacy Text and Dimension Conversion settings only affect plans from previous versions when they are opened in Home Designer Pro. Set these values to the default font that you used in previous versions before opening legacy files.

- 2** Click the arrow to select a font for the specified use. See “Fonts and Alphabets” on page 745.
- 3** Select one or more font styles to apply to the specified use.
- 4** Sample text displays the selected font and font style.

Text size is set individually in the **Text Specification** dialog or globally in the **Text Defaults** dialog. See “Text, Callouts & Markers” on page 743.

Library Browser Panel

The Library Browser panel controls the appearance of the Library Browser window. See “The Library Browser” on page 604.

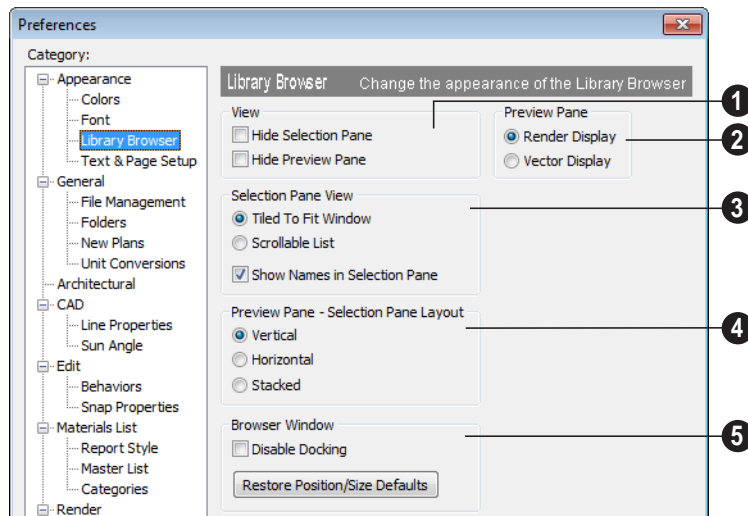

- 1 **View options** control the display of the main sections of the Library Browser.
 - **Hide Selection Pane** - Check to hide the pane that displays objects in a selected library or library folder.
 - **Hide Preview Pane** - Check to hide the pane that shows a preview of a selected object.
 - **Show Status Bar** - Check to display the Library Browser Status Bar.
- 2 **Preview Pane** - Specify how selected library items look in the Preview Pane.
 - **Render Display** - Library items previews display textures and appear as they do in rendered 3D views. See “Types of 3D Views” on page 664.
 - **Vector Display** - Library item previews are line-based and display patterns as they do in 3D Vector Views.
- 3 **Selection Pane View** items control the display style of objects in the Selection Pane.
 - **Tiled to Fit Window** - Select to display all objects in a library or library folder. If there are many objects, they appear very small.
 - **Scrollable List** - Select to display all library objects at the highlighted level on a scrollable list.
 - **Show Names in Selection Pane** - Check to display the names of the objects in the Selection Pane.
- 4 **Preview Pane - Selection Pane Layout** - Select a radio button to change the appearance of the Library Browser.
 - **Vertical** - Displayed sections of the Library Browser are divided vertically.
 - **Horizontal** - Displayed sections are divided horizontally.
 - **Stacked** - Displayed sections are divided both horizontally and vertically.
- 5 **Disable Docking** - Check to prevent the Library Browser from docking to the sides of the Home Designer Pro window. See “Docking the Library Browser” on page 608.

Click the **Restore Position/Size Defaults** button to restore the original position and size of the Library Browser: docked on the right side of the Home Designer Pro window.

Text & Page Setup Panel

The Text & Page Setup panel controls some text objects behaviors as well as the Page Setup information for legacy plan and layout files.



Legacy Plan and Layout Page Setup settings only affect files from 6 when they are opened in Version 2014. You should set these values to the default font that you used in previous versions of Home Designer Pro before opening legacy files. See “What’s New in Home Designer Pro 2014” on page 917.

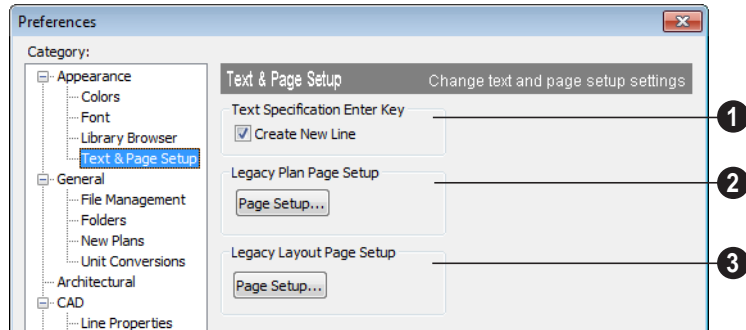

1 Uncheck **Text Specification Enter Key** to close the **Text** and **Rich Text Specification** dialogs when the Enter key is pressed. When checked, a new line of text is created when Enter is pressed. See “Text, Callouts & Markers” on page 743.

2 Click the **Legacy Plan Page Setup** button to open the **Page Setup** dialog. These settings apply whenever you open a

plan, or elevation, created in version 6 of Home Designer Pro. See “Page Setup Dialog” on page 853.

3 Click the **Legacy Layout Page Setup** button to open the **Page Setup** dialog. These settings applied whenever you open a layout file created in an earlier version of Home Designer Pro. See “Page Setup Dialog” on page 853.

General Panel

The General panel contains settings that affect file management and program updates.

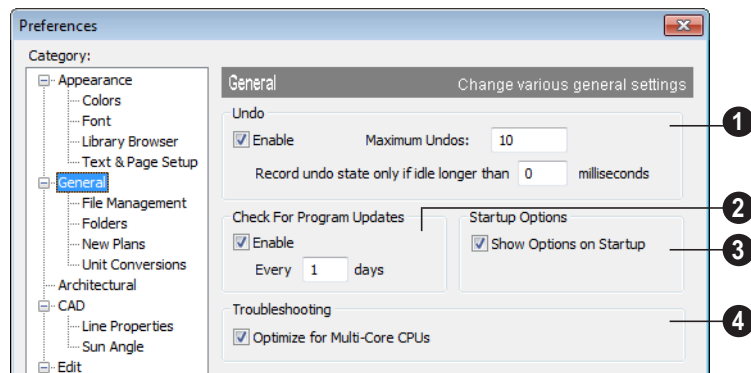

1 **Undo** - Click in the **Enable** check box to enable Undos and Redos. See “Undo

and Redo” on page 173.

Maximum Undos - Specify how many levels of Undo and Redo you want available, from 1 to 100. Undo files are saved in the Undo Directory.

Record undo state only if idle longer than - Use this setting to control how often undo states are recorded. If set to 0 milliseconds, an undo state is recorded every time a change is made to a plan.

If set to a number larger than 0, an undo state is recorded if the specified amount of time has elapsed since the last change was made. Depending on the time specified and the speed work is being done, multiple changes might be reversed with one undo.

This setting can have a significant effect on the performance of the undo feature when working with large plans.

2 Check For Program Updates - Check **Enable** and specify a frequency in days to check for program updates. By default Home Designer Pro will check for program updates once a day, whenever the program is launched.

3 Check Show Options at Startup to open the **Startup Options** dialog when Home Designer Pro is launched. See “Startup Options” on page 24.

4 Troubleshooting - Uncheck **Optimize for Multi-Core CPUs** to turn off program optimizations for multi core processors. This box is checked by default and should only be unchecked for technical troubleshooting purposes.

File Management Panel

The settings on the File Management panel let you modify functions related to the program’s plan and layout file management.

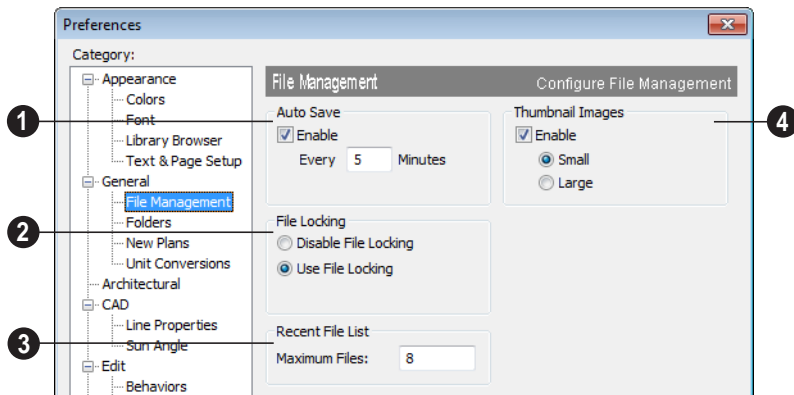

1 To use **Auto Save**, select the **Enable** check box and enter a value greater than zero in the text field to specify the

frequency in minutes that Auto Save files are created. Auto Save files are stored in the Archive folder.

 Even with Auto Save active, you should frequently save your work to the hard drive by selecting File> Save.

In the event that your computer shuts down unexpectedly, you can recover your most recent work by opening the auto save file created by the program. See “Auto Save Files” on page 47.

2 File Locking - Choose whether or not to lock **.plan** and **.layout** files when they are open. File Locking prevents another program or copy of Chief Architect software from opening and modifying the same file at the same time.

- Select **Use File Locking** to lock files.
- Select **Disable File Locking** to disable the feature. You should not disable the

feature unless you have conflicts with file locking.

3 Recent File List - Specify the maximum number of files to list at the bottom of the File menu and in the **Startup Options** dialog. Additional files are included if you increase the value. You can open any of the files in this list by selecting them, making the list a quick way to access your most recent work.

4 Check Enable Thumbnail Images to automatically create thumbnail images of files that display when opening or searching for saved files. If this option is disabled, you can still create thumbnails manually. See “Thumbnail Images” on page 46.

Select either **Small** or **Large** thumbnails. Large thumbnails provide a higher quality image but result in larger file sizes.

Folders Panel

Home Designer Pro stores many support files in various folders on your computer. The default locations of these directories are listed and can be redefined on the Folders panel if necessary.

You do not need to change default locations under normal circumstances, but sometimes

it may be preferable to locate certain files in another location. To specify a new default folder for a particular purpose, click the **Browse** button to the right of that item.

 Changing the settings on the Folders panel can result in unexpected program functionality.

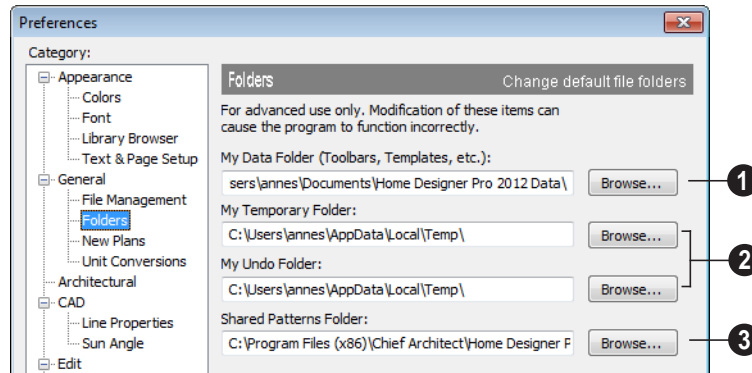

1 Important user-specific information is saved in a folder on your computer called **Home Designer Pro 2014 Data**. This folder contains custom library content, toolbars, template files, archive files, and other important data and is located in My Documents by default. See “Home Designer Pro Data” on page 41.

While you cannot change the name of this directory, you can change its location. To avoid unexpected results, it is best to use a location on your local hard drive.

If you move this folder on your computer without specifying its location here, the program will automatically replace it using default information from the Home Designer Pro installation folder. The same result will occur if you specify a location on a network or removable device and this location becomes inaccessible. When this occurs, customized user settings will not be used and custom library content will not be available.

2 By default, **Temporary** files and **Undo** files are stored in the same folder: by default, the Windows Temporary Directory. If you wish to use a different folder, you must specify a directory on a hard drive with sufficient space to hold these files.

You can specify any directory as your Home Designer Pro temporary folder, but you should never relocate the Windows Temporary Directory nor use it for anything other than temporary files.

Home Designer Pro will not let you save your work to or open files saved in the Temporary or Undo folder. See “Undo and Redo” on page 173.

3 You can share **Patterns** with other users by copying these items into the appropriate Shared Folder in Windows Explorer. Click the **Browse** button to select a location on your computer that other users can access. See “Patterns and Textures” on page 632.

New Plans Panel

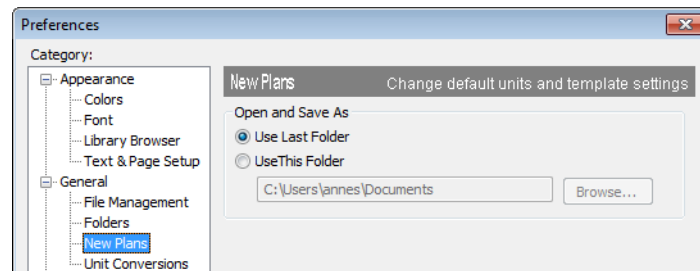

Open/Save As Directory - Control how the program behaves when a new plan is opened or an existing plan is saved.

- **Use Last Directory** refers the program to the directory last used to save or open a plan file.

- **Use This Directory** refers the program to a particular location specified by you.
- Click the **Browse** button to define a particular directory when **Use This Directory** is selected.

Unit Conversions Panel

In many places throughout Home Designer Pro, you can specify the size of an object with any Length unit listed on the Unit Conversions panel. Using the data on this panel, the program will convert your entry into the unit set in the **Number Style/Angle Style** dialog. See “Number Style/Angle Style Dialog” on page 89.

These conversions are also useful when you import drawings. When an object is drawn in

a Home Designer Pro plan file, it is always at its true, unscaled size and the drawing is only scaled when you print it. This means that if you import a scaled drawing, you must compensate for its scaling by creating a custom unit of measurement. See “Import Drawing Wizard” on page 829.

The default unit conversions are locked and cannot be changed, but custom conversions can be added to the list and later modified.

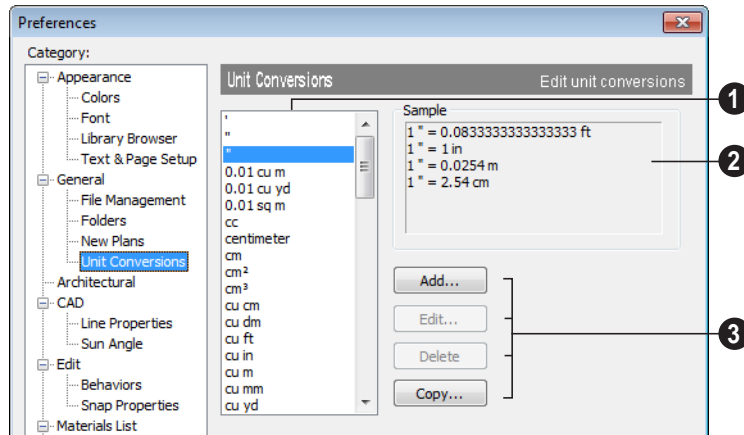

- 1 A list of available units of measurement displays here. Click on the name of a unit to select it.
- 2 The **Sample** area shows how the unit selected above converts to a selection

of similar units. You can use this to verify that any unit conversion you add is correct.

- 3 **Add, Edit, Delete,** or **Copy** the unit conversions. Certain unit conversions are locked and cannot be edited or deleted.

If you click **Add, Edit** or **Copy**, the **Add Unit Conversion** dialog displays.

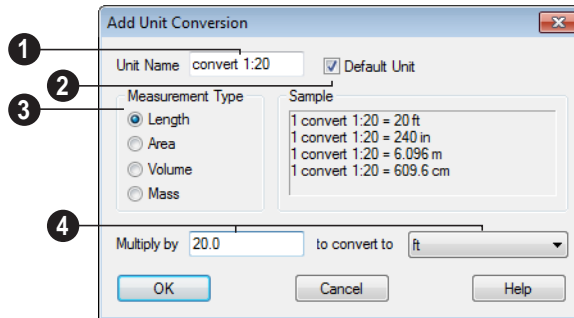

- 1 **Unit Name** - Type a short, descriptive name of the new unit. Names must be unique: the names of units installed with the program cannot be used.

Names can include any characters, as well as spaces. Bear in mind, though, that names of

units for measuring length that have numbers in them may be unusable if entered in some dialogs in the program.

- 2 Check **Default Unit** to display this new unit in places that present lists of available units. For example, if you have

inches as units and make inches a default, inches appear on the list when you are given a choice of units, such as in the **Import Drawing Wizard**. In other places, such as the Materials List, all units are listed.

3 Measurement Type specifies what the new unit measures. Select the appropriate radio button.

4 Multiply by gives you a number to multiply by **to convert to** the unit you select from the drop-down list. A measurement type must be selected before the list is populated.

To create a new unit of measurement

When importing a drawing with a 1" = 20' scale, for example, create a unit to convert this scaling to 1" = 1".

1. Click the **Add** button to open the **Add Unit Conversion** dialog.
2. Type a short, descriptive name like "convert 1:20" in the **Unit Name** field.
 - Because this unit will be used only for scaling conversion, including numbers in its name will not cause any issues.
3. Select **Length** as the **Measurement Type**.
4. Type 20 in the **Multiply by** field.
5. Select "ft" from the drop-down list.

Note: You can achieve the same results if you Multiply by 240 to convert to inches.

6. Click **OK** to close the dialog.

Architectural Panel

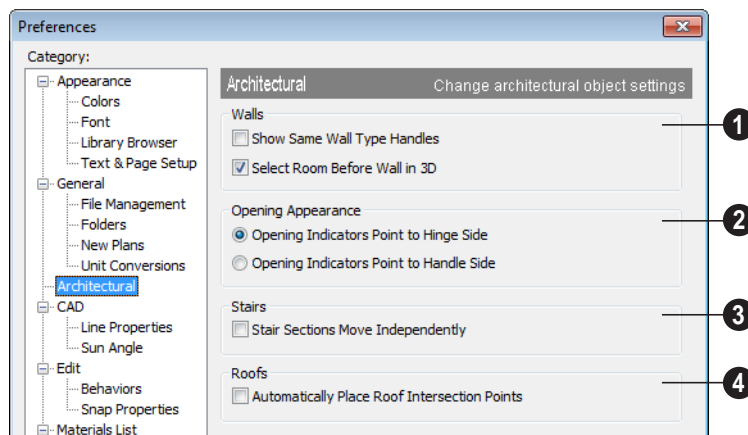

- 1** Select the desired default behaviors for selected **Walls**.
 - Check **Show Same Wall Type Handles** to display edit handles on selected walls

that draw new walls of the same type when dragged. See "Same Wall Type Edit Handles" on page 198.

- Check **Select Room Before Wall in 3D** to select the room defined by a wall when you click on the wall in 3D views. See “Selecting Walls” on page 197.
- ② **Opening Appearance** - Specify the appearance of opening indicators on cabinets, doors, and windows. See “Displaying Cabinets” on page 514, “Displaying Doors” on page 257, or “Displaying Windows” on page 287.
- Select **Opening Indicators Point to Hinge Side** for opening indicators that point to the hinge side of the opening.
- Select **Opening Indicators Point to Handle Side** for opening indicators that point to the handle side of the opening.
- ③ Check **Stair Sections Move Independently** to allow stair sections connected by landings to move separately, without moving the entire staircase. See “Editing Stairs and Ramps” on page 403.
- ④ Check **Automatically Place Roof Intersection Points** to have the program generate temporary CAD points that correspond to roof plane intersection points. When unchecked, these temporary points are not created. See “Locating Intersections” on page 367.

CAD Panel

The CAD panel controls whether or not objects snap together to form polylines and

objects that behave like polylines. See “Polylines” on page 790.

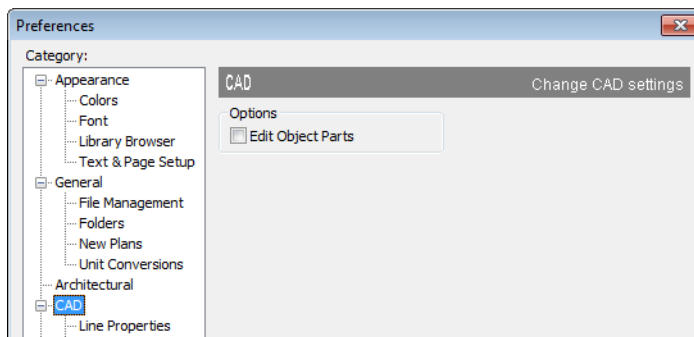

- Check **Edit Object Parts** to edit the individual components of a polyline or polyline-like object. This functionality can also be accessed by clicking the **Edit Object Parts**  button. See “Edit Object Parts” on page 125.

Note: Unlike other Preferences, the program always resets Edit Object Parts to be off whenever you close the program.

Line Properties Panel

The Line Properties panel controls the appearance of CAD lines.

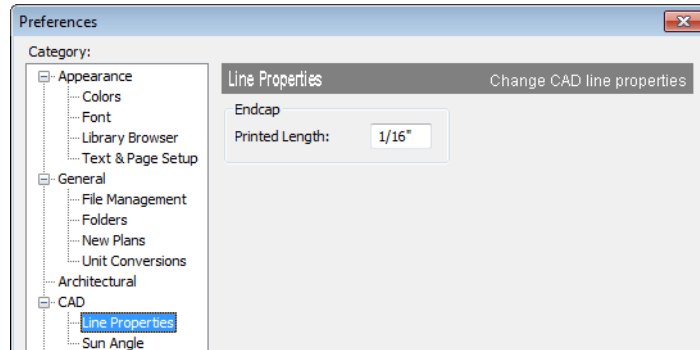

Printed Length - The beginning and end of CAD lines that are not solid are sometimes difficult to distinguish. Endcaps can be

placed to eliminate this problem. Specify the printed endcap length in inches (mm).

Sun Angle Panel

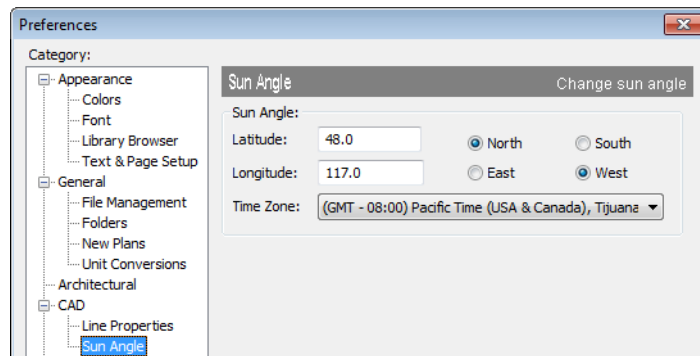

Define a default **Latitude**, **Longitude** and **Time Zone** used when creating Sun Angles.

See “Sun Angles” on page 701.

Edit Panel

The settings on the Edit panel of the **Preferences** dialog control the appearance of the cursor and selection behavior of edit handles. See “Using the Mouse Cross Hairs” on page 154.

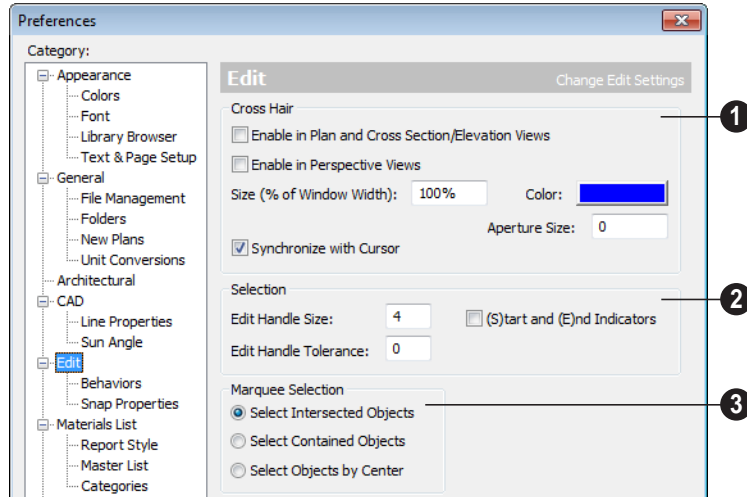

1 Use a cursor with **Cross Hairs** in different view types and control its appearance.



- Check **Enable in Plan and Cross Section/Elevation Views** to use a cross hair cursor in floor plan and cross section/elevation views. This option is checked by default.
- Check **Enable in Perspective Views** to use a cross hair cursor in perspective camera views and overviews.
- Click the **Color** bar to open the **Color Chooser** dialog and specify the color of the cross hairs.

- Cross hair size is specified as a percentage of the width of the view window. Specify the **Size (% of Window Width)** as 100% to extend the cross hairs across the entire screen.
- Set the **Aperture Size**, measured in pixels. The aperture is the space where the cross hairs meet. A value of 0 makes the cross hairs meet at a point. Larger numbers leave a gap in the center.
- When **Synchronize with Cursor** is checked, the mouse pointer and cross hairs always move together on screen. If you feel that they do not keep up with your mouse movements, try unchecking this option.

2 Specify the desired **Selection** settings, which affect how objects are selected and their appearance.

- Enter an **Edit Handle Size** in pixels. The edit handles are twice this number of pixels plus one. For example, the default value is 3, which results in a handle that is 7 x 7 pixels (3 x 2=6, and 6 + 1=7). A value of 1 results in a handle that is 3 x 3 pixels.
- Enter a value, in pixels, for **Edit Handle Tolerance** to specify how close to an edit handle you must click in order to select it. The default value is 0.
- Check **(S)tart and (E)nd Indicators** to display an S and an E at the start and end points of a selected wall or the selected edge of a CAD-based object. This can make it easier to edit the selected edge in the object's specification dialog. See "Selected Edge" on page 125.

3 Specify program behavior when using **Marquee Selection** to select objects. See "Marquee Select" on page 126.

- Choose **Select Intersected Objects**  to select any objects whose bounding boxes are intersected by or located within the marquee.
- Choose **Select Contained Objects**  to select only objects located entirely within the marquee. This option provides the best results in most situations.
- Choose **Select Objects by Center**  to select only objects whose center points are located within the marquee.



You can add the Selection Modes tools to your toolbars. See "To add a button to a toolbar" on page 94.

Behaviors Panel

The settings on the Behaviors panel of the **Preferences** dialog define basic editing behaviors of CAD and architectural objects.

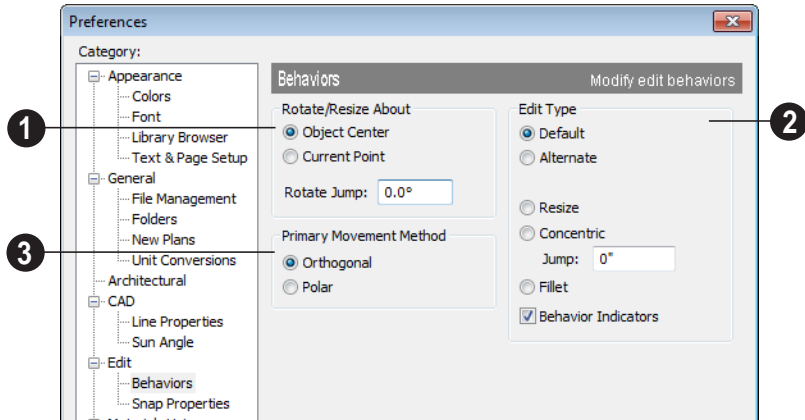

1 **Rotate/Resize About** defines the point an object or a group of objects rotates or resizes about. See “Rotate/Resize About” on page 109.

- Select **Object Center** to rotate or resize the selection about its center point. Object Center is the default setting.
- Select **Current Point** to rotate the object about the current CAD point instead.

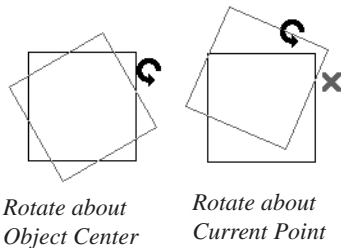

This function can also be accessed by selecting **Edit > Edit Behaviors >**

Resize . See “Edit Behaviors” on page 120.

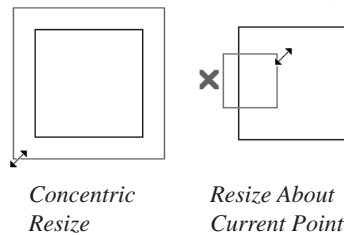

Rotate Jump defines the angle an object or group of objects jumps to when it is rotated. It overrides the angle snaps set in **Plan Defaults**. If you set this to zero, the angle snaps set under **Plan Defaults** are used.

To resize a CAD object about a current point, select the **Resize** Edit Type.

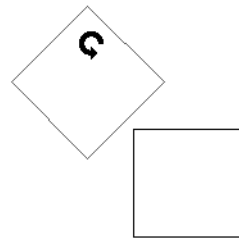

Box rotating about Current Point with Jump set to 45°

2 Select one of the four **Edit Type** options. For detailed information about the different edit types and how they affect different objects, see “Edit Behaviors” on page 120.

- If **Concentric** is selected, specify the desired **Jump** increment.
- Uncheck **Behavior Indicators** to turn off the display of the mouse pointer icons associated with these Edit Behaviors. This box is checked by default.

Note: Unlike other Preferences, the program always restores the Default Edit Behavior whenever you close the program.

3 The **Primary Movement Methods** control the directions that you can move objects using their edit handles.

- Select **Orthogonal** to move an object perpendicular to any of its edges.
- Select **Polar** to move an object at Allowed Angles.

Snap Properties Panel

The settings on the Snap Properties panel of the **Preferences** dialog control the behavior of Object Snaps as well as the appearance of snap indicators. See “Object Snaps” on page 110.

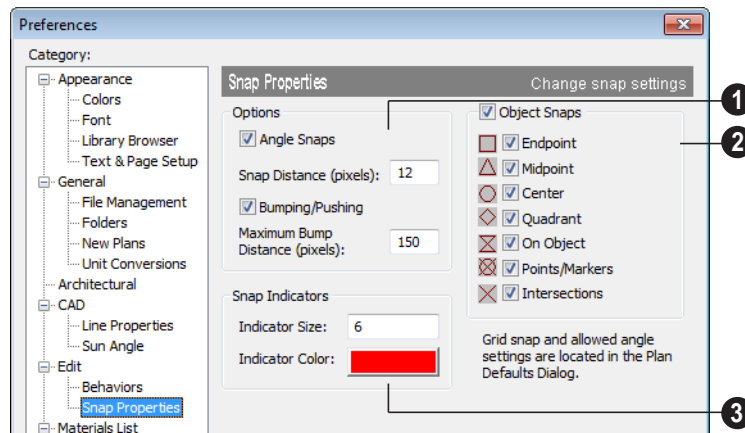

1 Options -

- Check **Angle Snaps**  to enable snapping to Allowed Angles. See “Angle Snaps” on page 111.
- Specify the **Snap Distance (pixels)**, which is how far your the cursor can be from a snap point for the snap to occur. This value is measured in screen pixels; the default value is 12.

When working with very small objects, you may find it helpful to reduce this value; when working with very large objects, you may find it helpful to increase it.

This setting also controls the minimum length of camera and cross section/elevation lines of sight. See “Creating Camera Views” on page 673.

- Check **Bumping/Pushing**  to enable bumping and pushing. See “Bumping/Pushing” on page 152.
- Specify the **Maximum Bump Distance (pixels)**, which is the distance that a selected object must be dragged to override bumping and move past an obstructing object.

- 2** Enable any combination of **Object Snaps**. You can also turn these options on an off with the toggle buttons on the toolbar.

Check **Object Snaps** to enable the object snap options, below.

 **Endpoint** - Enables snapping to the ends of lines, arcs, splines and other objects.

 **Midpoint** - Enables snapping to the midpoint of an object such as a line or arc. For objects such as boxes, you can snap to the midpoint of any side of the box.

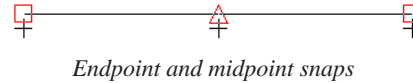

 **Center** - Enables snapping to the center of cabinets, fixtures, furniture, as well as circles and arcs.

Note: Center snapping only works for arcs and circles if Show Arc Centers and Ends is turned on. See “Aligning Arc Centers” on page 156.

 **Quadrant** - Enables snapping to the left, right, top, or bottom of an object. Only used for arcs and circles.

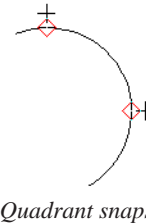

 **On Object** - Enables snapping to any point on the selected object, including CAD objects and cabinets.

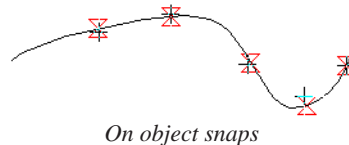

 **Points/Markers** - Allows you to snap to any temporary points you may have placed, as well as callouts and markers.

 *Points/Markers snaps*

 **Intersection** - Enables snapping to the intersection of two objects, such as the intersection of a line with another line. Intersection snapping also snaps extension lines to objects, and allows you to snap two extension lines to each other.

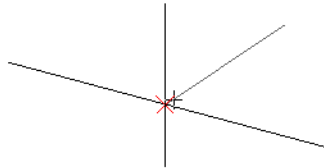

Intersection snaps

When Intersection snapping is enabled, wall extension line snapping will also occur. See “Drawing Walls” on page 189.

3 Control the appearance of **Snap Indicators**.

- Specify a snap **Indicator Size** in pixels.
- Click the color bar to select a snap **Indicator Color** from the **Color Chooser** dialog. See “Color Chooser Dialog” on page 651.

Materials List Panel

The settings on the Materials List panel control which categories are included in Materials Lists. The names of all categories

and their ID prefixes are listed here. They are defined by the program and cannot be changed.

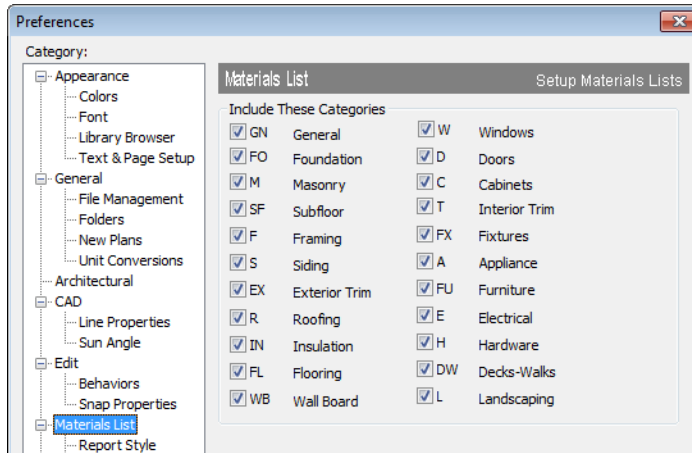

When a material is entered in the Materials List, the program decides what category it goes in and assigns it an ID, which is the prefix followed by a number. EX1 would be the first exterior trim piece entered in the Materials List for a particular plan.

Include These Categories - Check the categories you want to include in every

new materials list generated. Before you hide a category, make sure you know what items are listed within it.



It is usually better to remove categories from individual plan lists in the Layer Display Options dialog, rather than globally. See "Layer Display Options Dialog" on page 104.

Report Style Panel

The Report Style panel controls the initial appearance of Materials Lists. Most of these options can also be specified per individual Materials List by choosing **Tools> Display**

Options while that Materials List is active. See “Materials List Display Options Dialog” on page 891.

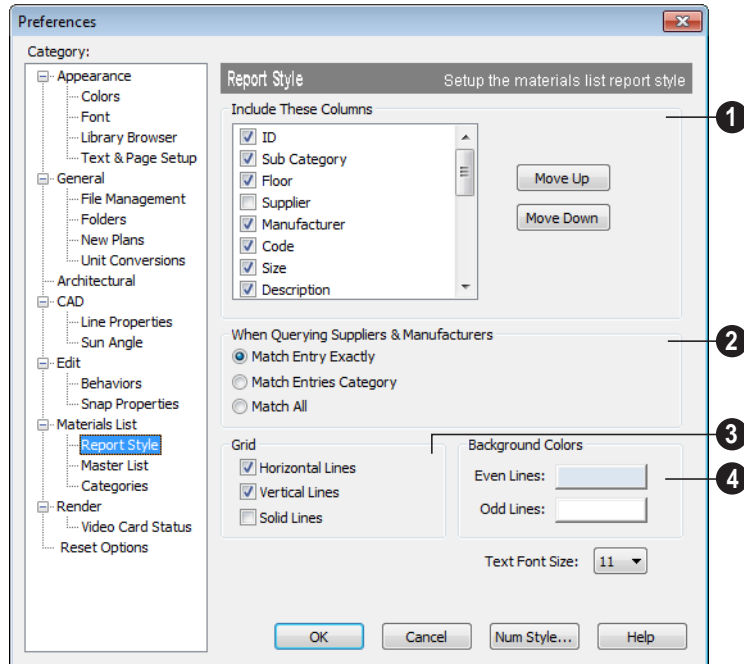

1 Include These Columns - Check the columns that should be included in the Materials List.

Use the **Move Up** and **Move Down** buttons to change the order that columns appear. To change the order, select one or more items in the list and click the button. The selected columns move up or down by one in the list.

For a more detailed description of Materials Lists, see “Materials Lists” on page 887.

2 When Querying Suppliers & Manufacturers - Select an option to

narrow or broaden your query when searching the Master List.

3 Grid - Choose whether or not grid lines display in the materials list. If you want lines, choose to have horizontal, vertical, or both. If the lines are turned off, they do not show on-screen or in print. You can select **Solid Lines** for the grids instead of dotted lines.

4 Background Colors can be set for even and odd numbered lines.

- 5 Specify the **Text Font Size**, which is the height of the font used in the Materials List, Master List and the

Components dialog. See “Character Size” on page 745.

Master List Panel

The Master List panel specifies how the Master List(s) for materials appears. Master Lists contain price and manufacturer information for materials. You can maintain

Multiple Master Lists, but only one may be used at any given time. See “Materials Lists” on page 887.

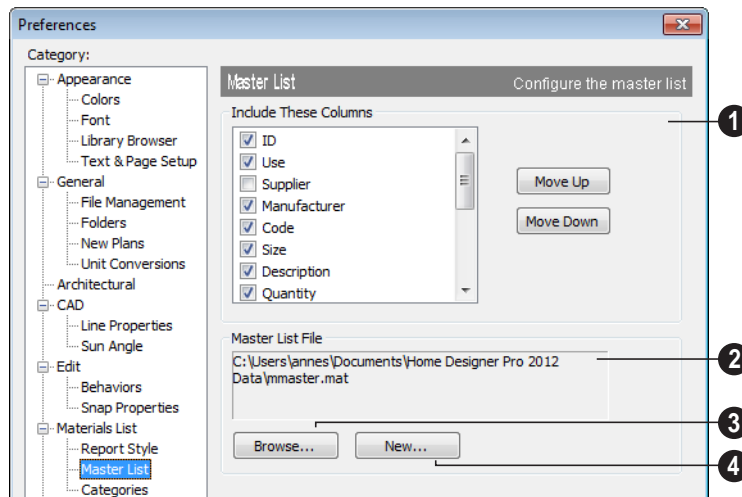

- 1 **Include These Columns** - Check each column to include it in the Master materials list.

Use the **Move Up** and **Move Down** buttons to change the order of columns. To change the order, select one or more items in the list and click the button. The selected columns move up or down by one in the list.

- 2 **Master List File** - The name and pathname of the Master List currently referenced is shown. It is referenced for all subsequently opened plans when a materials list is generated from any model.

- 3 Press **Browse** to select a different Master List. Navigate the directory structure until you find the new Master List to be used, select it, and click **OK**.

- 4 Press **New** to create a new Master List. Name and save it in the location of your choice. When you create a new Master List, it is blank until you build a materials list and enter prices, supplier or manufacturer information. The Master List is saved automatically when you close.

Categories Panel

The Categories panel allows you to customize the organization of the Materials List by creating subcategories under the pre-defined Materials List categories. See “Organizing Materials Lists” on page 889.

Subcategories may also be included in schedules in the Chief Architect program. See “Upgrade to Chief Architect” on page 907.

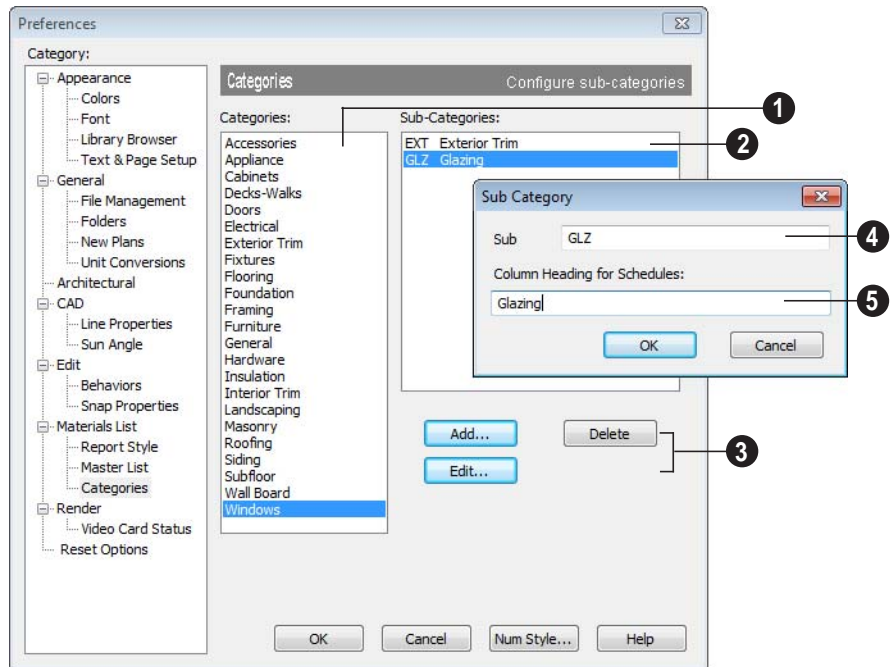

To create or modify a subcategory

- 1 Select a **Category** from the list.
- 2 Existing subcategories display here.
- 3 To **Add**, **Edit** or **Delete** a subcategory, select it and click the appropriate button. Clicking **Add** or **Edit** opens the **Sub-Category** dialog.
- 4 In the **Sub Category** dialog, type a name of the subcategory to appear in the **SubCat** column of the Materials List.

The **Sub Cat** name can be any sequence of characters, up to 12 characters in length.

- 5 Doors, Windows, Cabinets, Fixtures, Furniture, and Electrical objects can generate schedules in Chief Architect. Type a **Column Heading for Schedules**.

In the example above, two subcategories are added to the **Windows** category: **GLZ** (Glazing) and **EXT** (Exterior Trim).

Render Panel

The Render panel settings control how 3D views are generated, particularly Render

Previews and Final Views. See “Previews vs Final Views” on page 698.

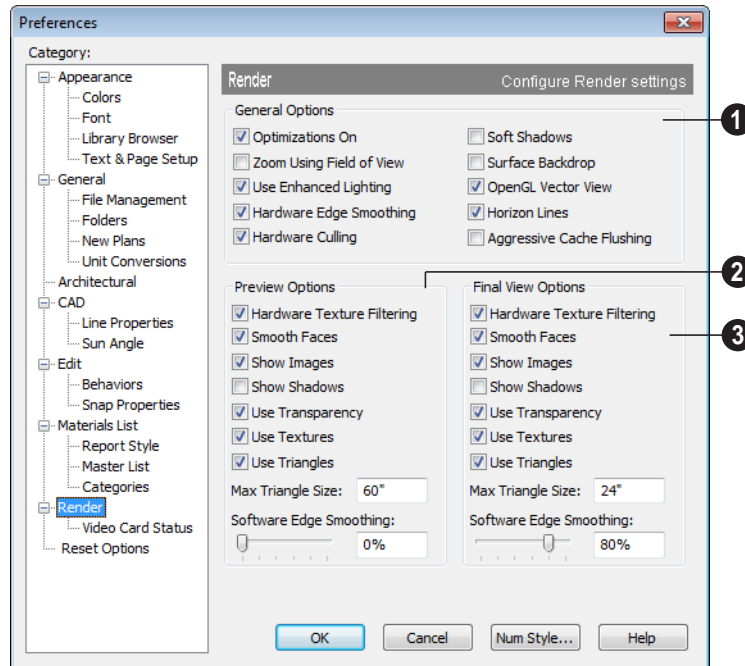

1 The **General Options** settings affect both Render Previews and Final Views.

- **Optimizations On** saves rendering data to your video card, which speeds up rendering time. This option may cause problems if the rendering data for your model exceeds the video card’s memory.

If your computer stops responding when rendering, try unchecking **Optimizations On**. This slows down rendering time considerably, though, so if the problem is not solved, leave this check box selected.

- **Zoom Using Field of View** directs the program to zoom in 3D views by adjust-

ing the camera’s Field of View, which can result in perspective distortion. See “Field of View” on page 686.

When **Zoom Using Field of View** is unchecked, zooming in 3D views is done by cropping or expanding the view’s extents. See “Zooming” on page 686.

- When **Use Enhanced Lighting** is checked, Standard rendered views generate lighting effects that require a video card that supports OpenGL 2.0. Unchecking this box may speed up Standard rendering times somewhat; however, the quality of lighting effects will be reduced.

Not available if your video card does not support OpenGL 2.0. See “OpenGL and Hardware” on page 664.

- **Hardware Edge Smoothing** uses the video card to remove the jagged edges that sometimes result along surface edges, producing cleaner lines. Not available if your video card does not support this feature.
- **Hardware Culling** improves rendering times by preventing surfaces not actually visible in the scene from being generated. On some systems, this setting may slow down rendering times. If unchecking it does not solve the problem, though, leave this check box selected. See “System Requirements” on page 7 of the User’s Guide.
- **Soft Shadows** displays shadows with soft edges instead of hard edges. This feature is only used when Show Shadows and a Software Edge Smoothing value greater than 0% are also used. See “Rendering Tips” on page 697.
- **Surface Backdrop** generates the backdrop image using hardware acceleration. For some graphics cards, this option improves rendering speed considerably.
- **Horizon Lines** are lines that generate along the curved edges of symbol objects in Vector Views. Uncheck this box to increase the speed of Vector View generation but also suppress these lines. See “Vector View” on page 711.
- **Aggressive Cache Flushing** regularly flushes cached video memory, which may be helpful for older video cards. On most systems, unchecking this box will produce faster rendering times.

- **OpenGL Vector View** directs the program to generate Vector Views using OpenGL hardware acceleration. See “OpenGL and Hardware” on page 664.

If you encounter problems creating Vector Views, try unchecking **OpenGL Vector View**. This slows down Vector View generation time considerably, though, so if the problem is not solved, leave this check box selected.

Note: If OpenGL Vector View is not selected, you can create Vector Views but cannot apply any of the other Rendering Techniques to them. See “Rendering Techniques” on page 710.

- ② The **Preview Options** settings affect only Render Previews.
- **Hardware Texture Filtering** uses your video card to filter textures and improve their appearance: noticeably, on surfaces angled away from the camera. In some rare instances, this may slow rendering time somewhat. Not supported by some video cards.
- **Smooth Faces** generates smooth curved surfaces. It uses new surface normals to alter the lighting effects on surfaces, making them appear curved, even though it does not alter the shape of the surfaces.
- **Show Images** controls the display of images, such as plants, cars and people, in rendered views. See “Displaying Images” on page 807.
- **Show Shadows** controls whether or not shadows display. Shadows are extremely complex to calculate and slow down rendering speed significantly, particularly

when multiple lights are set to cast shadows. They are typically used only for Final Views. See “Lighting” on page 699.

- **Use Transparency** allows materials such as window glass to display effects. For some video cards, rendering may be slowed when this feature is selected.
- **Use Textures** controls whether or not surfaces are rendered with textures. This only affects surfaces with materials that have assigned textures. When textures are turned off, surfaces are rendered using the color assigned to the material, but not the texture. See “Mapping Patterns and Textures” on page 638.

Textures can also be turned on or off rendered views by selecting **3D > Camera View Options > Toggle Textures** .

- **Use Triangles** divides large surfaces, such as walls, floors, and ceilings, into small triangles. This feature enhances lighting effects when point or spot light sources are used. Triangles are not used by the Standard, Technical Illustration or Vector View rendering techniques.
- **Max Triangle Size** controls the size of the surface triangles modeled by the program. Lighting looks better with smaller

triangles, but rendering takes longer. See “Rendering Tips” on page 697.

The initial settings for Previews and Final Views are 60” (1500 mm) and 24” (600 mm), respectively. The minimum value is 6” (150 mm).

- **Software Edge Smoothing** removes the jagged edges that sometimes result along surface edges, producing cleaner lines. Use the slide bar or text field to specify how much jagged edge lines should be smoothed.

Initial Software Edge Smoothing settings for Previews and Final Views are 0% and 80%, respectively.

- 3 The **Final View Options** settings are exactly the same as the Preview Options, but affect Final Views instead of Render Previews. See “Previews vs Final Views” on page 698
- 4 Select a **Codec for walkthrough recordings** from the drop-down list. “Cinepak codec” is selected by default; but any other codecs that you may have installed on your system will also display in the list. See “Walkthroughs” on page 819.

Video Card Status Panel

The Video Card Status panel displays information about your video card, including the vendor and the version of OpenGL it uses. See “OpenGL and Hardware” on page 664.

This information may be important if you are having problems generating 3D views.

Notice the information following the **Acceleration** label. If your video card supports hardware acceleration for OpenGL, this says “Installed Client Driver.” If it does not, it says “No Hardware Acceleration.” There is a significant difference in speed between rendering with acceleration and without.

The **Max Lights** value indicates how many lights you can have turned on at any given time when generating a 3D view. This value

should be 8 or higher, depending on your video card. See “Lighting” on page 699.

Reset Options Panel

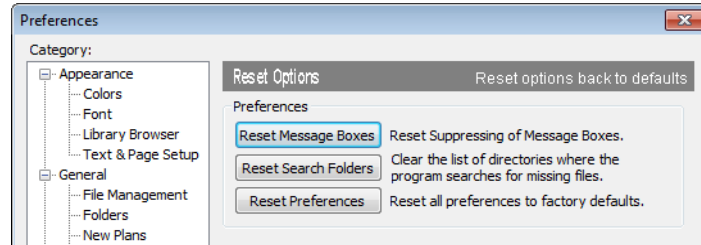

If message boxes have been suppressed, you can make them display again by clicking **Reset Message Boxes**.

Home Designer Pro retains a list of locations where you have located missing files in the past. If you find that the program takes a long time to search for files before informing you that they are missing, you can click the **Reset Search Folders** button to clear this list.

Click the **Reset Preferences** button to restore all preferences to those that originally came with the program. For the reset to take effect, you will need to restart the program.



Resetting all preferences to default can be a drastic step if you have made many changes to your defaults and should be done with caution.

Number Style/Angle Style Dialog

At the bottom of many dialogs, you can click the **Num Style/Angle Style** button to open the **Number Style/Angle Style** dialog.

The settings in this dialog are global and control the format of distances, coordinates and angles of angles in dialog boxes as well as in the Status Bar. See “The Status Bar” on page 31.

These settings control the format of values used in dialogs but do not limit how you must enter these values. For example, if you set your Number Style to use Inches, values will display using fractional inches. You can, however, enter values using decimal inches, inches and feet, or even decimal feet. When the dialog you’re typing in updates, the value will be converted to fractional inches.

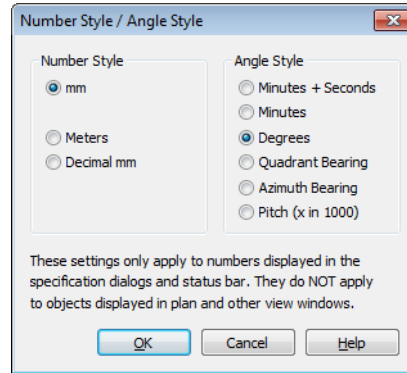
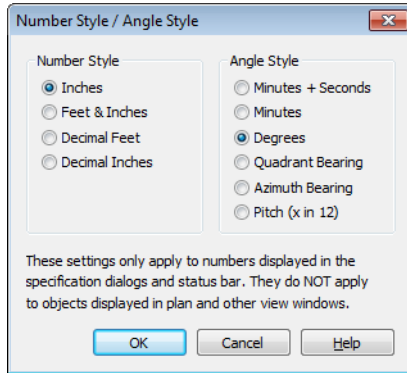

When Imperial units are used, the **Inches** and **Feet & Inches** options use fractional inches with denominators of 2, 4, 8 and 16. A few objects, notably text, dimensions, and floor, ceiling and wall structure layers can be sized using smaller fractions with larger denominators.

Angles can be displayed using one of four basic methods:

- **Degrees/Minutes/Bearings** - Measured counterclockwise from a line drawn horizontally to the right of the angle's vertex. Useful for most drawing tasks. Select the level of accuracy that you require.
- **Quadrant Bearings** - Measured from a vertical line representing North/ South, Quadrant Bearings use directional bear-

ings in their measurements. Useful for site drawings.

- **Azimuth Bearings** - Measured from a line drawn straight up from the angle's vertex (ie, North on a site plan). Useful for site drawings, Azimuth Bearings use degrees, minutes, and seconds in their measurements.
- **Pitch** - Defined as a ratio of vertical rise to horizontal run. In Imperial units, the run is always 12"; in metric units it is 1000 mm. Useful for roofs.

Quadrant and Azimuth Bearings are affected by the orientation of the **North Pointer** , if one is present in the current plan. See "North Pointer" on page 778.

Toolbars & Hotkeys

Two of the most efficient ways to access Home Designer Pro's tools are the toolbars and keyboard shortcuts, also referred to as hotkeys.

Toolbars are organized into configurations, which are basically collections of multiple toolbars arranged for use during specific drawing tasks. Within a given toolbar configuration, buttons are arranged so that similar tools are located near one another.

Chapter Contents

- Toolbar Arrangement
- Customizing Toolbars
- Toolbar Configurations
- Hotkeys

Toolbar Arrangement

Home Designer Pro installs a set of Toolbar Configurations, which determines what tools are initially included in the toolbars, as well as where these toolbars are located.

Toolbar Preferences

Toolbars can be viewed in Drop-Down or Parent-Child arrangement. You can specify which to use in the **Preferences** dialog. See “Appearance Panel” on page 61.

Drop-Down toolbar buttons have an arrow to the right of the button that accesses additional, related tools.

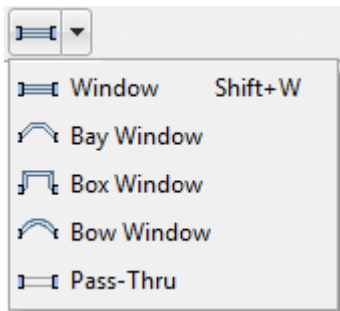

Alternatively, you can use the Parent-Child toolbar arrangement. In this arrangement, you select a “parent” button to display its “child” buttons to the right.



You can also turn off the display of toolbars entirely by selecting **Tools > Toolbars > Hide Toolbars**.

Moving Toolbars

You can, if you wish, move any toolbar to a different location. Toolbars can be docked to any side of the program window, or they can be undocked and left floating. Undocked toolbars can also be moved outside of the program window.

Toolbars are saved between program sessions. To restore the original toolbar locations, as well as their display, click the **Reset Toolbars** button in the **Toolbar Customization** dialog. See “Toolbar Tab” on page 96.

Restoring Toolbars

Toolbars can be moved, added to and removed from any toolbar configuration.

If you make changes to a configuration, they will be saved whenever you:

- Switch to a different configuration;
- Close the **Toolbar Configuration** dialog;
- Exit out of Home Designer Pro.

To discard your changes and restore all toolbar configurations to their original condition, click the **Reset Toolbars** button in the **Toolbar Configuration** dialog. See “Toolbar Tab” on page 96.

Customizing Toolbars

You can create custom toolbars as well as entire custom toolbar configurations in the **Toolbar Customization** dialog. In this dialog, you can:

- Add and remove buttons from toolbars.
- Specify which of the available toolbars display in different view types.
- Select the active toolbar configuration.

Toolbar Customization Dialog

Select **Tools > Toolbars > Customize Toolbars** to open this dialog.

Tools Tab

The Tools tab allows you to add or remove buttons from your toolbars.

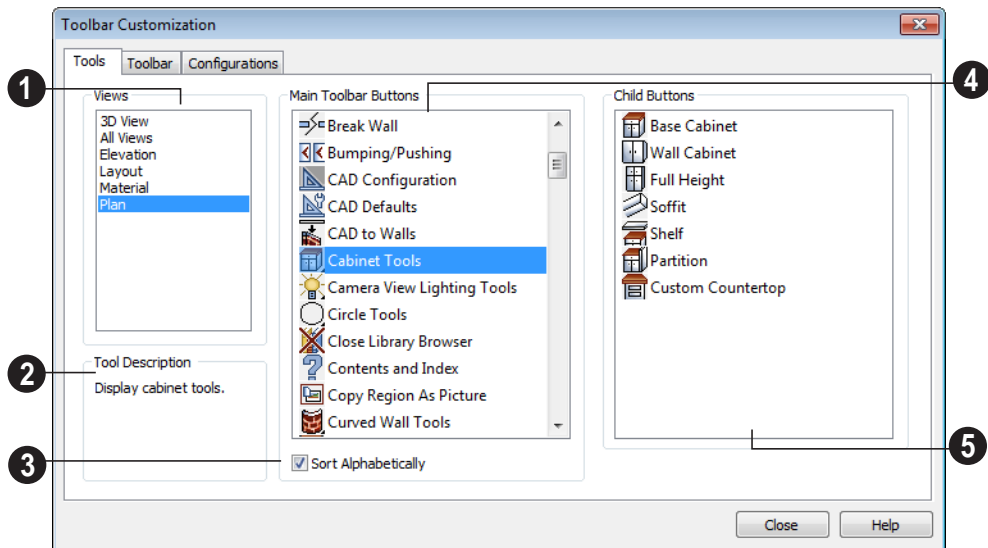

1 Select the type of **View** you would like to add toolbar buttons in. As you select various views, the tools available change.

2 A description of the selected button displays here.

3 Check **Sort Alphabetically** to sort the tools in alphabetical order rather than the order they appear on the toolbars.

4 A list of the **Main Toolbar Buttons** available for the selected View displays here.

Click on a button to display any child buttons to the right and a description at the lower left of the dialog. See “Parent and Child Tools” on page 28.

If you do not see a particular button in the list, it may not be available in the currently selected View, or it may be the child of a parent tool.



You can use the Empty Space button in your toolbars as a spacer.

5 Click on a button in the “Main Toolbar Buttons” area to display its child buttons in this **Child Buttons** area. If no child buttons display, the button you selected is not a parent tool.

In the image above, the **Cabinet Tools**  parent button is selected under “Main Toolbar Buttons” and its child tools display under “Child Buttons”.

Child tools are permanently associated with the parent tool. If, for example, you add the

Cabinet Tools  parent button to a toolbar, its child tools will always display whenever it is selected. An individual child tool can, however, be placed on a toolbar by itself.

To add a button to a toolbar

1. Select the **View** type that you want to add a toolbar button in.
2. Select the desired button or its parent from the **Main Toolbar Buttons** list.
3. If the desired button is a child button, select it from the **Child Buttons** list.
4. Click and drag the button you wish to add to a toolbar out of the dialog box.

- Drop it onto an existing toolbar to add the button to that toolbar.
- Drop it away from an existing toolbar to create a new toolbar. The selected button is first in the new toolbar. The new toolbar is named with the current view followed by a number.

To create a new toolbar

1. Select the **View** type to which you want to add a new toolbar.
 - If you select All Views, your new toolbar will display in all views.
 - You can add any buttons you like to an All Views toolbar; however, not all buttons will necessarily be available for use in all views.
2. Select the first button that you want on the toolbar from the **Main Toolbar Buttons** or **Child Buttons** areas.
3. Click and drag the button out of the dialog box and drop it:
 - In an empty section of the program window border to create a new toolbar docked at that location.
 - In the drawing area to create a new, undocked toolbar.
4. Additional buttons can be added to this new toolbar.
5. After you click Done, you can return to this dialog to assign a name to your new toolbar. See “Toolbar Tab” on page 96.

An undocked toolbar can be docked, or vice versa, at any time.

Removing Tools from Toolbars

To remove a button from a toolbar, select **Tools > Toolbars > Customize Toolbars** to

open the **Toolbar Customization** dialog. With this dialog open, click and drag the button off its toolbar.

Buttons cannot be added to or removed from the Edit toolbar. See “The Edit Toolbar” on page 29.

 You can only remove a button from a toolbar when the Toolbar Customization dialog is open.

Toolbar Tab

The Toolbar tab allows you to manage your individual toolbars.

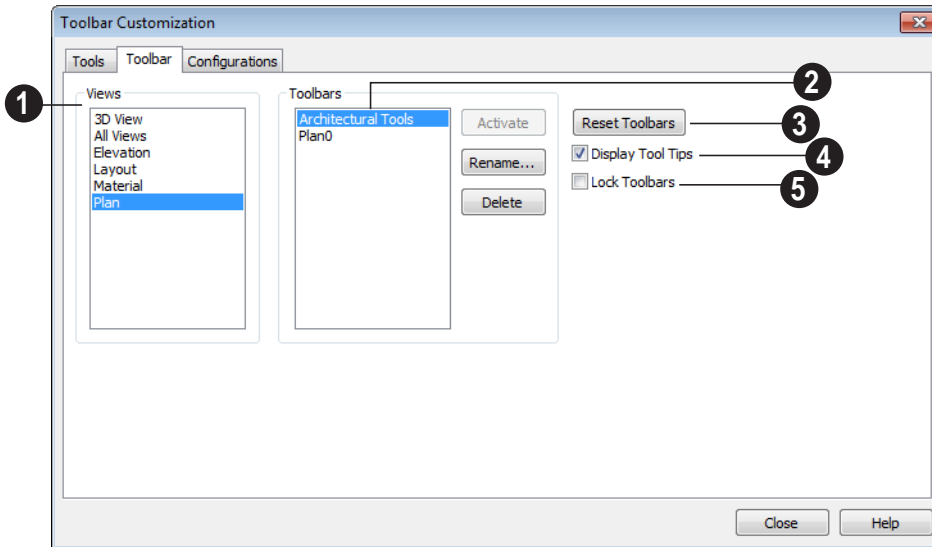

- 1 Select a type of **View** to display the toolbars available for use in it.
- 2 The toolbars available for the selected View display here. Select a toolbar by clicking on its name.
 - If the selected toolbar is not active, the **Activate** button is available. Click **Activate** to make the selected toolbar active.
 - Click **Rename** to rename the selected toolbar. Toolbar names must be unique.
 - Click **Delete** to remove the selected toolbar from the list. A deleted toolbar is no longer available.

- 3 Click **Reset Toolbars** to restore all the toolbars to their original configuration. See “Restoring Toolbars” on page 92.



Clicking on the Reset Toolbars button deletes any toolbar customization you have done.

- 4 Check **Display Tool Tips** to show Tool Tips when you move the cursor over buttons.
- 5 Check **Lock Toolbars** to lock toolbars in their current position on screen.

Configurations Tab

The Configurations tab allows you to add, remove and switch between toolbar

configurations. See “Toolbar Configurations” on page 98.

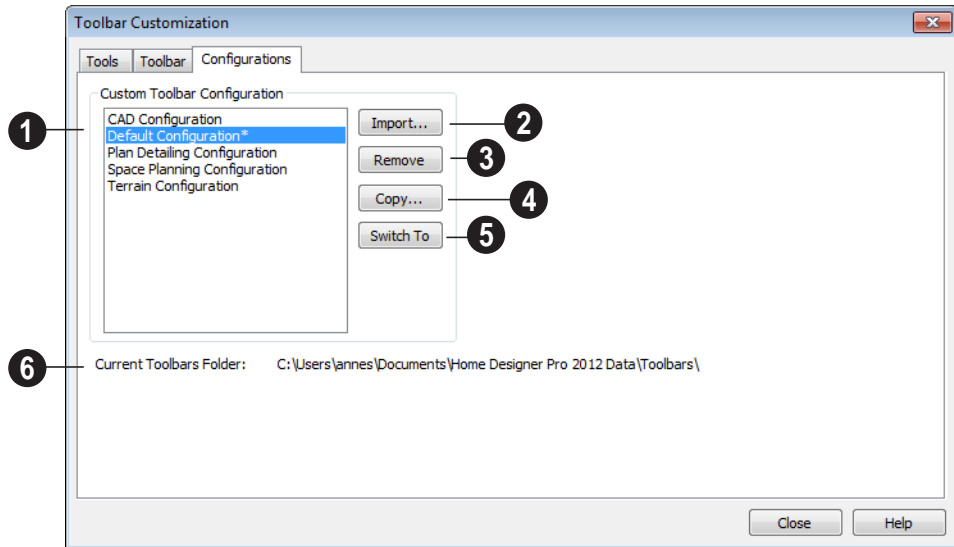

- 1 A list of toolbar configurations displays here. Select a configuration before clicking the **Remove**, **Copy**, or **Switch To** buttons.
- 2 **Add** - Click to browse for a toolbar configuration file and add it to the list.
- 3 **Remove** - Click to remove the selected toolbar configuration. This removes the configuration from the list but does not delete the configuration file permanently.
- 4 **Copy** - Click to create a copy of the selected toolbar configuration.

- 5 **Switch To** - Click to switch to the selected toolbar configuration. You can also right-click on any toolbar and select a configuration from the menu, or click a **Toolbar Configuration** button.





- 6 The location of the **Current Toolbars Folder** displays here. It can be specified in the **Preferences** dialog. See “Folders Panel” on page 69.

Note: If you customize your toolbars, it is a good idea to back up your toolbar configuration files (*.toolbar). See “Home Designer Pro Data” on page 41.

Toolbar Configurations

The Home Designer Pro program window has limited space for toolbar buttons. How many can be shown depends on your monitor's size and screen resolution settings.

The toolbar configurations that come with Home Designer Pro organize tools based on the type of work being done as well as on monitor screen resolution.

- The **Default Configuration**  displays architectural tools used for house design, including walls, windows, doors, stairs, cabinets, etc.
- The **Terrain Configuration**  displays buttons associated with the terrain and road tools, including the plant and sprinkler tools. See “Terrain Toolbar Configuration” on page 538.
- The **Space Planning Configuration**  displays buttons associated with the House Wizard. See “House Wizard” on page 799.
- The **Plan Detailing Configuration**  is designed for dealing with materials lists, time tracking, and client and designer information.
- **CAD Configuration**  shows the tools needed for CAD drawings. See “CAD Objects” on page 769.

To switch toolbar configurations

There are several ways to switch from one toolbar configuration to another.

- Click a Toolbar Configuration button.

- Choose a configuration in the **Toolbar Customization** dialog. See “Configurations Tab” on page 97.
- Right-click on a toolbar and select a configuration from the contextual menu.

To create a custom configuration

You can create a custom configuration that shows only the buttons you need.

1. Access the Configurations tab of the **Toolbar Customization** dialog.
2. Select a configuration similar to the one you want to create and click **Copy**.
3. Give the new configuration a name. It should be saved to the Home Designer Pro Toolbars folder. See “Home Designer Pro Data” on page 41.
4. Click **Save**. The program switches to the new configuration and it appears highlighted in the list.
5. Drag tools you want to add out of the **Toolbar Customization** dialog and onto the toolbars.
6. Drag any tools you do not want off the toolbars.
7. When you are satisfied with the appearance of your new toolbar, click **Close**.

You can make your own button icon for your custom toolbar configuration. Create a **.bmp** file with the same name as the configuration and save it in the Toolbars folder. To see an example, look at the Default.bmp file in the Home Designer Pro Toolbars folder, which corresponds to the Default Toolbar configuration.

- Toolbar button bitmaps must be 20 x 20 pixels in size.
- The color (R:192, G:192, B:192) maps to the system 3D face color.
- The color (R:128, G:128, B:128) maps to the system 3D Shadow color.
- The color (R:223, G:223, B:223) maps to the system 3D light color.

To import a custom configuration

You can import an existing toolbar configuration.

1. Access the Configurations tab of the **Toolbar Customization** dialog.
2. Click **Add**.
3. Browse to the location of the toolbar you want to import.
4. Click **Open**. If the **.toolbar** file is not in the Home Designer Pro Toolbars folder, a copy of the file will be created there.

Hotkeys

Many Home Designer Pro tools have a keyboard shortcut, or hotkey, associated with them. If such a hotkey exists, it will display to the right of the tool's name in the menu.

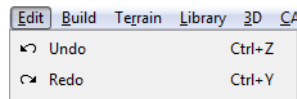

Edit menu items with button icons to the left and hotkeys to the right

To use a hotkey, simply press the appropriate key or combination of keys on your keyboard instead of selecting the menu item or clicking the toolbar button. For example, press the Ctrl and Z keys at the same time to perform an **Undo** .

Layers

Layers are used to organize and manage the display of all objects in all views. A layer can be thought of as a transparency sheet with objects placed on it for viewing. Nearly all views use multiple layers, like a stack of transparencies put together to show different types of objects.

You can customize how each layer displays in a particular view in the **Layer Display Options** dialog.

Multiple layers are organized into Layer Sets, which allow you to control which objects display in different views.

Chapter Contents

- Displaying Objects
- Layer Sets
- Layer Display Options Dialog

Displaying Objects

The display of objects in different views is controlled by layer sets and layers in the **Layer Display Options** dialog. See “Layer Display Options Dialog” on page 104.

Primary and Secondary Layers

Every object is placed on a layer which controls whether it displays in a given view. This layer is referred to as the object’s primary layer.

In addition, some objects have secondary layers which may alter the appearance of objects on the primary layer, but do not control whether the objects display or not.

For example, the primary layer for base cabinets is “Cabinets, Base”. In addition, base cabinets have a number of secondary layers that control the display of the countertop, face indicators, door opening indicators, module lines and labels.

Note: If an object’s primary layer is turned off, information on its secondary layers will not display - even if those layers are turned on.

All layers with a check in the “Disp.” column display when the current layer set is active. Objects that are not displayed cannot be seen or selected. If you try to place or draw an object on a layer that is hidden, the program asks if you want to turn the layer on.

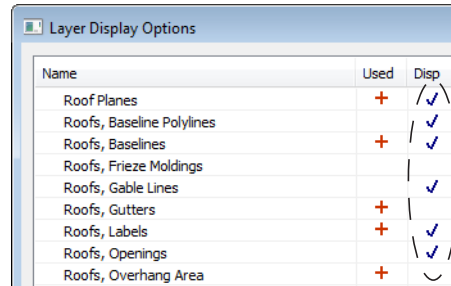

Some objects cannot stand alone in a drawing: they can only be inserted into another object. If the display of an object that contains an inserted object is turned off, the display of the inserted object will be turned off, as well. For example, if the display of a wall is turned off, any doors and windows in that wall will not display either. See “Inserted Objects” on page 621.

Line and Text Styles

A layer’s **Color**, **Style**, **Size** and **Text Style** attributes determine how an object on that layer appears in floor plan view and in 3D views using the Vector View rendering technique.

Color	Line Style	Size	Text Style
Grey	— — — —	25	Default Text Style
Blue	————	10	Default Label Style
Black	————	18	Default Text Style
Black	————	25	Default Text Style
Red	- - - - -	25	Default Text Style

Many objects, including all CAD and text objects, allow you to override these settings for an individual instance without changing its layer.

Locking Layers

Objects on layers with a lock symbol in the **Lock** column cannot be selected by the user.

Name	Used	Disp	Lock
Roofs, Baselines	+	✓	(🔒)
Roofs, Frieze Moldings			(🔒)
Roofs, Gable Lines		✓	(🔒)
Roofs, Gutters	+		(🔒)
Roofs, Labels	+	✓	(🔒)
Roofs, Openings		✓	(🔒)
Roofs, Overhang Area	+		(🔒)

New objects cannot be drawn on a locked layer, either. If you lock a layer and then attempt to draw a new object on that layer, a message box will ask you to unlock the layer.

Layers with objects that you need to see as a reference while working, but not select, are good candidates for locking. For example:

- Locking the “Rooms” layer can make it easier to select objects located inside of rooms.
- Locking the “Roof Planes” layer can make it easier to select objects located under the eaves.



Locking a layer does not prevent objects on that layer from being modified. Most objects can be deleted using the Delete Objects dialog. Objects are also deleted if the floor they are placed on is deleted. See “Deleting Objects” on page 171.

Layer Sets

Layer Sets are used to control the layer settings for different views in a plan or layout file. All views associated with a plan file - including views sent to layout - make use of layer sets stored in that **.plan** file.

A layer set consists of a complete list of the layers in the current plan or layout along with the display settings for each layer as set for a particular type of view. These display settings can be modified, and can be different for each type of view. See “Layer Display Options Dialog” on page 104.

Layer sets are file specific, which means that changes made in one plan or layout file have no effect on the settings in other files.

Home Designer Pro uses a different layer set for the each type of view of your plan:

- Floor plan view.

- Aerial Views. See “Aerial View” on page 660.
- Camera views and Overviews. See “3D View Tools” on page 672.
- Elevation views. See “Cross Section/Elevation Views” on page 675.
- Framing Overviews. See “Framing Overview” on page 675.
- Reference Display. See “The Reference Floor” on page 327.
- Print Model. See “Print Model” on page 858.

While any view is active, select **Tools>**

Display Settings> Display Options  to make changes to the layer set used for that view type.

Any changes made to settings in the **Layer Display Options** dialog for one particular

view will affect all views using that same layer set. For example, if you make changes for a camera view, all camera views and overviews in the current plan will be

affected. See “Layer Display Options Dialog” on page 104.

Unlike other layer sets, the Aerial View and Print Model layer sets cannot be modified.

Layer Display Options Dialog

 The **Layer Display Options** dialog controls the display of layers in the active layer set. It consists of a table that lists all available layers and the attributes for each.

From any view except the Materials List, select **Tools > Display Settings > Display**

Options  to open the **Layer Display Options** dialog. This dialog is resizable and maintains its size between program sessions.

Selecting **Tools > Reference Floors >**

Reference Display Options  opens the **Layer Display Options** dialog with the Reference Display Set active. See “The Reference Floor” on page 327.

Selecting **Tools > Display Options**  in a materials list opens the **Materials List Display Options** dialog. See “Materials List Display Options Dialog” on page 891.

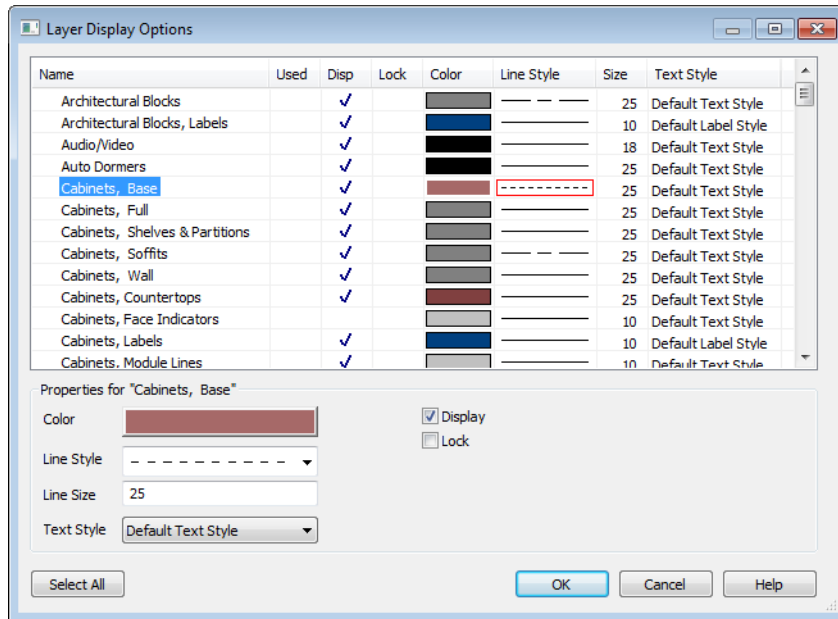

Click the column header to sort all layers in the **Layer Display Options** dialog by that column.

- The **Name** column is sorted alphabetically. Sorting is also case sensitive to allow greater control over organization.
- A red + in the **Used** column indicates which layers have objects placed on them in the current plan. This column cannot be edited.
- A check in the **Disp** column indicates which layers are set to be visible. This controls the display of objects in 2D and 3D views.
- A yellow  in the **Lock** column indicates which layers are locked, preventing objects on that layer from being manually edited.
- The **Color** column shows the line color for each layer. You can sort this column so that like colors are listed together.
- The **Line Style** column shows the line style for each layer and can be sorted so that like line styles are listed together.
- The **Size** column displays the line weight used by each layer and can be sorted so that like line weights are listed together. See “Line Weights” on page 849.
- The **Text Style** column shows the text style assigned to each layer and can be sorted so that layers using the same style are listed together. See “Text Styles” on page 765.

Layers are named so that similar object types such as Cabinets, Base and Cabinets, Wall are listed near one another alphabetically.

If a layer is turned on, a checkmark is shown in the Disp column. If a layer is turned off, the column is blank.

Layers are selected by clicking them in the table. Hold down the Shift key or the Ctrl key to select multiple layers at once. Click the **Select All** button to select all layers in the table. When selected, a layer’s attributes display at the bottom of the dialog. If multiple layers are selected, “no change” may display for attributes that are different among the selected layers.



When one or more layers are selected and you click OK, the program remembers your selection so that the same layers are selected when you reopen the Layer Display Options dialog.

When a layer or layers is selected, single or shared layer attributes can be edited in the section titled **Properties for “Selected Layer”**. Line Color, Style and Size affect lines in floor plan view and surface edge lines in vector views.

- To change the color of lines on a selected layer, click the **Color** bar to select a new color in the **Color Chooser** dialog. See “Color Chooser Dialog” on page 651.
- To change the width of lines on a selected layer, enter a **Line Size**. See “Line Weights” on page 849.
- To change the **Line Style** of a selected layer, click the drop-down arrow.
- To change the **Text Style** of a selected layer, click the drop-down arrow. See “Text Style Defaults” on page 765.
- To turn off a selected layer, uncheck **Display**. See “Displaying Objects” on page 102.

- To protect the objects on a selected layer from accidental changes, check **Lock**. Items on locked layers display but cannot be selected. See “Locking Layers” on page 103.

Note: Not all objects display in all views. For instance, door labels do not appear in 3D views.

Creating Objects

There are a wide variety of objects in Home Designer Pro that you can use to create complete 3D models and working drawings. Although these objects are sometimes very different from one another, the methods used to create them are similar.

Once an object is created, it can be selected and edited to meet the requirements of your project. The editing characteristics common to most objects are described elsewhere. See “Editing Objects” on page 119.

Chapter Contents

- Architectural vs CAD Objects
- Defaults and Preferences
- Snap Behaviors
- Object Snaps
- Angle Snaps
- Grid Snaps
- Creating Objects
- Copying and Pasting Objects

Architectural vs CAD Objects

There are two broad categories of objects in Home Designer Pro: architectural objects and CAD objects.

CAD objects such as lines, arcs, text, and dimensions are 2D objects that can be created and edited in floor plan view and cross section/elevation views, and on layout pages but do not display in 3D camera views and overviews. See “The CAD Drawing Tools” on page 771.

In contrast, architectural objects such as walls, cabinets, doors, windows, and stairs display in 2D and 3D views. Architectural objects can be created and edited in 2D and 3D views but not on layout pages.

Some architectural objects, such as custom countertops and slabs, have some behaviors in common with CAD objects and are referred to as CAD-based.

Defaults and Preferences

The ways that objects in the program behave as they are created and edited are affected by a number of default and preference settings. See “Preferences & Default Settings” on page 55.



It is a good idea to be familiar with these options and how they affect both drawing and editing in the program.

Snap Settings



Select **Edit > Snap Settings** to access the three categories of Snap Settings that determine how objects snap to one another and whether they snap to allowed angles or to points on a grid, as well as object bumping and pushing behaviors.



Object Snaps enable snapping to objects. See “Object Snaps” on page 110.



Angle Snaps enable snapping at Allowed Angles. See “Angle Snaps” on page 111.



Grid Snaps enable snapping to the Snap Grid. See “Grid Snaps” on page 112.



Bumping/Pushing enables bumping and pushing behaviors. See “Bumping/Pushing” on page 152.

Edit Behaviors



Select **Edit > Edit Behaviors** to access the six global edit behavior modes that determine how dragging the edit handles with the left mouse button affects a selected object and may also affect how objects are drawn.



The **Default** edit behavior provides the most commonly used editing options. See “Default” on page 120.



The **Alternate** edit behavior provides an alternative to the Default behaviors

that may be more useful in some situations. See “Alternate” on page 121.



The **Resize** edit behavior scales an object as you drag a corner handle. See “Resize” on page 121.



The **Concentric** edit behavior allows you to resize objects so that the distance moved by each edge is the same as all other edges. See “Concentric” on page 122.



The **Fillet** edit behavior allows you to add a fillet at any corner of an object. See “Fillet” on page 123.

Edit Object Parts



Select **Edit> Edit Behaviors> Edit Object Parts** to toggle the ability to edit the individual segments of polyline-based objects and connected walls. It also affects the ability to snap line- and arc-based objects together as they are drawn to form a polyline. See “Edit Object Parts” on page 125.

Rotate/Resize About



Objects can be rotated or resized about either their own centers or the Current CAD point. See “Point Tools” on page 772.

Specify which behavior is used by selecting **Edit> Edit Behaviors> Rotate/Resize**

About Current Point  or in the **Preferences** dialog. See “Behaviors Panel” on page 78.

Arc Creation Modes



Select **Edit> Arc Creation Modes** to access the five Arc Creation Modes that control how arcs and curved walls are drawn.





Free Form Arc mode allows you to define an arc by clicking and dragging along the desired path. See “Free Form Arc” on page 784.

Snap Behaviors



There are three categories of snap behavior in Home Designer Pro that affect how objects are created and how they can be edited:

- **Object Snaps** , which snap CAD and architectural objects to other objects.
- **Angle Snaps** , which snap objects at specific angles.
- **Grid Snaps** , which snap objects to points on a grid.

Snap behaviors can be controlled in the **Preferences** dialog and in the **Plan** or **Layout Defaults** dialogs. See “Snap Properties Panel” on page 79 and “General Plan Defaults Dialog” on page 58.

You can select **Edit> Snap Settings**  to quickly turn Object, Angle and Grid Snaps on or off.

To temporarily disable Snap Behaviors and other move restrictions, press the Ctrl key

while dragging an edit handle. See “Moving Objects” on page 152.

Hotkeys

You can also temporarily enable individual Snap Behaviors during a mouse editing operation using hotkeys. This can be helpful if you wish to use one particular type of snap behavior when you begin an operation, but a different behavior when you end it.

The Snap Behavior hotkeys are listed on the right side of the **Edit> Snap Settings**  submenu. See “Hotkeys” on page 99.

To use snap behavior hotkeys

1. Select **Edit> Snap Settings**  and toggle off the snap behavior category that you wish to control using hotkeys.

2. Select a tool that you wish to draw with or an object you wish to edit.
3. Begin drawing or editing and hold down the left mouse button without releasing.
4. Press and hold the appropriate key on your keyboard to enable the snap behavior associated with it.
5. When you are finished using the snap behavior, release the hotkey but continue holding down your left mouse button.
6. If you wish, you can press and hold a different hotkey on your keyboard and continue the drawing or editing operation.
7. When you are finished, release the left mouse button.

Object Snaps





Object Snaps allow you to position objects precisely relative to each other; for example, to position lines so that their endpoints meet or roof plane edges so that they are colinear.

Object Snaps can be turned on or off by selecting **Edit> Snap Settings> Object**

Snaps , by clicking the toggle button, or in the **Preferences** dialog. See “Snap Properties Panel” on page 79.

Object Snaps are indicated visually as you create or edit objects. To remove any object snap indicators that are visible on screen, press the 1 (one) key. As you continue drawing or editing, new indicators may appear.

With the exception of **On Object**  snaps, have priority over all other types of snapping in Home Designer Pro. **Bumping/Pushing**  overrides Object Snaps. See “Bumping/Pushing” on page 152.

Object Snap Locations

There are many locations on an object that other objects can snap to. Each type of object snap can be toggled by selecting **Edit> Snap**

Settings  or in the **Preferences** dialog. See “Snap Properties Panel” on page 79.

Regardless of which Object Snaps are active, when multiple objects are selected the selection set’s only snap point is its midpoint.

Extension Snaps

Extension snaps allow you to snap to a point that is not actually on an object. Instead, these snaps locate points that are either colinear to the end of a wall or orthogonal (at a 90° angle) to it.

Extension snaps function when you are drawing or editing walls and create a “sticky

point” and blue extension line where the wall being drawn reaches a point that is either colinear or orthogonal to another wall’s end point. See “Drawing Walls” on page 189.

Object Snaps Hotkeys

- Hold down the “S” key to temporarily disable Object Snaps.

Angle Snaps



It is often important that objects be drawn at exact angles. This can be accomplished using **Angle Snaps**.

Angle Snaps allow you to draw lines, walls, and other objects at specified Allowed Angles. Angle Snaps also affect the way objects rotate, the radius of arcs, and a variety of other operations.

Angle Snaps allow you to snap at either 15° or 7.5° angles plus any additional Allowed Angles that you may specify. See “General Plan Defaults Dialog” on page 58.

Angle Snaps can be turned on or off by selecting **Edit> Snap Settings> Angle**

Snaps , by clicking the toggle button, or in the **Preferences** dialog. See “Snap Properties Panel” on page 79.

Angle Snap Settings

You can change Allowed Angle settings for Angle Snaps in the **Plan Defaults** or **Layout Defaults** dialog. See “General Plan Defaults Dialog” on page 58.

Specify **15 Degree** or **7 ½ Degree** angle snaps. When **7 ½ Degree** Angle Snaps are

selected, you can also specify **Additional Angles**.

Angle Snaps and Object Snaps

Angle Snaps have a higher priority than Grid Snaps and **On Object Snaps** , but a lower priority to all other Object Snaps. If a valid Object Snap exists, the program uses that instead of an Angle Snap.



Walls are an exception to this snapping prioritization. When walls are drawn or edited, Angle Snaps take higher priority than Object Snaps. See “Drawing Walls” on page 189.

Sometimes both Angle Snaps and Object Snaps apply. For example, suppose a CAD line is drawn at 15° using Angle Snaps and another line is approached. You can draw the new line at 15° using **Intersection Snaps**  to snap to a point on the existing line.

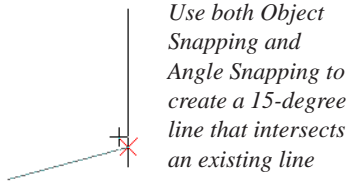

Now suppose that we don't want the new line to end on the existing line. Hold down the "S" key to temporarily disable Object Snaps, allowing only Angle Snaps.

Grid Snaps

 **Grid Snaps** allow you to snap objects to points on an on-screen grid. The display and size of this Snap Grid can be controlled in the **Plan** or **Layout Defaults** dialog. See "General Plan Defaults Dialog" on page 58.

Grid Snaps are turned on and off by selecting **Edit > Snap Settings > Grid Snaps** , by clicking the toggle button, or in the **Plan** or **Layout Defaults** dialog.

In addition to the Snap Grid, the **Reference Grid** is provided to give you a visual sense of scale. The Reference Grid is useful for zooming in and out, or for general layout guidelines, but is not used for snapping.

Grid Snaps and Angle Snaps

Of the three snap behaviors, Grid Snaps have the lowest priority and are overridden by Angle Snaps and Object Snaps.

When Grid snaps and Angle Snaps are both enabled, objects are drawn and edited using Polar Coordinates. For example, if the grid **Snap Unit** is set to 12" (1 foot), drawing a new wall at an Allowed Angle snaps the wall length to 0", 12", 24", and so on.

 To draw a line or wall at an Allowed Angle but with unrestricted length, disable Grid Snaps and leave Angle Snaps on.

Creating Objects

In Home Designer Pro, there are five ways to create objects: by clicking to place an object, by clicking and dragging to draw an object, by entering coordinates, or by importing custom symbols, drawings, pictures or metafiles.

If you create an object using any of these methods and the layer it will go on is either locked or turned off, the program will ask you if you want to display or unlock the

layer. Objects can be created on layers that are not set to display, but they cannot be created on locked layers. See "Object Creation and Layers" on page 114.

While the size of the drawing area in Home Designer Pro is limited only by the resources on your computer, it is best to begin your drawing near the origin, 0,0,0. The current position of your mouse pointer displays in

the Status Bar at the bottom of the program window. See “3D Drafting” on page 25.

Click-to-Create



Many objects, including doors and windows, cabinets, library symbols, terrain objects, text, pictures and images are created by clicking. Select a or library object, then click in the drawing area to place the object at that location.

Continue clicking to place the selected object until another tool is selected.

If you click at a location where there is not enough room for the object to be placed, one of two things may happen:

- Some objects, notably cabinets, doors, and windows, will resize smaller to fit into the space.
- Most objects cannot resize in this manner, so the program will present a warning message indicating that there is not sufficient space at the current location.

When most drawing tools are active or library symbols selected for placement, a preview outline follows your mouse pointer, indicating the size and shape of the object to be created. If your pointer is positioned at a location where the object cannot be placed, this preview outline will not display.

As you move the mouse pointer, the center point of the object’s back edge will snap to active snap points when **Grid Snaps**  or **Object Snaps**  are enabled. See “Snap Behaviors” on page 109.

Many architectural objects can be created in floor plan view or any 3D view. In order to place a stand-alone, click-to-create object in

3D, it is necessary to click near a wall or within the Terrain Perimeter as these objects help orient the new object within the 3D space.

Clicking and Dragging

Other objects, including walls and railings, straight stairs, and CAD and CAD-based objects are created by clicking and dragging to define either a path or an enclosed area. Select a tool, then click and drag in the drawing area to draw an object between your start and end points.

Continue drawing the selected object until another tool is selected.

You can temporarily slow the movement of the mouse as you drag by holding down the Shift key on your keyboard..

You can cancel any click-and-drag drawing operation before it is completed by pressing the Esc key on your keyboard, or by pressing any two mouse buttons at the same time.

Polyline- and Spline-based objects can be created by snapping multiple Line-, Arc-, and/or Spline-based objects together. These objects will only snap together to form a polyline or spline if they are on the same layer and share identical attributes such as color, line style, and arrow specifications. See “Editing Objects” on page 119.

Entering Coordinates

CAD lines, arcs and points can be created using the **Input Line**, **Input Arc** and **Input Point** dialogs. See “Input Point” on page 773, “Input Line” on page 777, or “Input Arc” on page 785.

Importing Objects

Custom symbols, drawings, pictures and metafiles can be imported into the program and placed in the drawing area with a click. See “Importing & Exporting” on page 827 and “Pictures, Images, & Walkthroughs” on page 805.

Converting Objects

A variety of objects can be created by converting existing CAD objects and many CAD-based objects into another type of object. See “Converting Objects” on page 164.

Object Creation and Layers

When it is created, every object is placed on a layer which controls whether and how it displays. See “Layers” on page 101.

If you try to create an object on a layer that is not set to display in the current view, the program will ask if you want to turn that layer on. See “Message Boxes” on page 32.

- Click **Yes** to create the object and turn on its layer in the current view.
- Click **No** to create the object but leave its layer turned off in the current view.
- Click **Cancel** to not create the object and leave the layer turned off.

If you try to create an object on a layer that is locked, the program will prompt you to unlock the layer. If you choose to leave the layer locked, the object will not be created. See “Locking Layers” on page 103.

Copying and Pasting Objects

New objects can also be created by cutting, copying, and pasting existing objects, either individually or in groups. Objects can be copied from one floor to another, one view window to another, and one file to another. Because copying uses the Windows Clipboard, some objects can be pasted into other applications, as well.

Objects cannot be pasted into any views that they cannot be created in normally. For example, CAD objects cannot be pasted into a 3D camera view or overview.

Similarly, architectural objects cannot be pasted onto a layout page.

A few objects, such as Terrain Perimeters and camera symbols, cannot be copied.

Cut



Select **Edit> Cut** to remove the selected object(s) from the file and save them in the Windows Clipboard. To paste the selection in Home Designer Pro or another application, select **Edit> Paste** or press **Ctrl + V** while in that application to enable the Paste function.

Copy



Select **Edit> Copy** to copy the selected object(s) to the Windows Clipboard. To paste the selection in Home

Designer Pro or another application, select **Edit> Paste** or press **Ctrl + V** while in that application to enable the Paste function.

Paste



Select **Edit> Paste** to enable Paste mode, then left- or right-click in the current view to paste the selected object(s) previously copied to the Windows Clipboard at that location.

Once pasted, these object(s) are selected. Objects pasted in 3D views are selected on their top surfaces.

If the selection being pasted consists of text, it is placed in a Text object.

If the selection being pasted is an image, the **Paste Image** dialog opens.

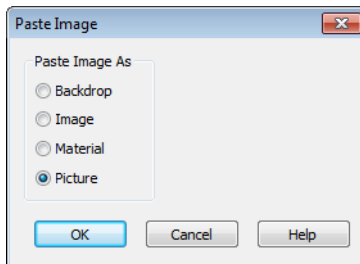

Specify how you would like to paste the selected image:

- Select **Backdrop** to add the image to the My Backdrops library category. The image will display in the preview panes. To use this backdrop, select **3D> 3D Settings**  from the menu. See “3D View Defaults Dialog” on page 668.
- Select **Image** to add the image to the My Images library category. The image will

display in the preview panes and will be selected. Click in the plan to place it.



- Select **Material** to add the image to the My Materials library category. The image will display in the preview panes. Select **3D> Materials> Material Painter**  to apply the material. See “The Material Painter” on page 632.
- Select **Picture** to display the picture in the current Home Designer Pro floor plan view. See “Importing Pictures” on page 812.

Copy/Paste



Click the **Copy/Paste** edit button to copy the selected object(s) to the Windows Clipboard and immediately enable the **Paste**  function in Home Designer Pro.

The **Copy/Paste**  edit button activates Paste mode in which each available edit tool and handle makes a copy in addition to its primary function and four new edit buttons display on the edit toolbar.



- Click the **Sticky Mode**  edit button remain in the current mode and place multiple copies of the selected object(s).
- Click the **Point to Point Move**  edit button to make a copy of the selection at a specific location. See “Point to Point Move” on page 153.
- Click the **Reflect About Object**  edit button to make a copy of the selection reflected about another object. See “Reflect About Object” on page 163.

- Click the **Main Edit Mode**  edit button or press the Esc key to return to the selected objects's main edit toolbar.



If you paste a selection in a file other than its original source file, when you return to the original, Paste mode is still enabled.

The **Copy/Paste**  edit button can be used with the edit handles in either of two ways: by clicking or by dragging an edit handle.

To Copy/Paste by clicking

1. Select an object or objects to copy.
2. Click the **Copy/Paste**  edit button, select **Edit> Copy**  from the menu or press **Ctrl + C** to copy and then **Ctrl + V** to activate the Paste functionality. The cursor displays the Copy/Paste icon.
3. If you wish to paste the copy in a different view or program window, open that window.
4. If your cursor does not display the Copy/Paste icon, select **Edit> Paste** from the menu or press **Ctrl + V**.
5. Left- or right-click once to paste a copy of the object at that location.

To Copy/Paste by dragging

1. Select an object or objects to copy.
2. Click the **Copy/Paste**  edit button, select **Edit> Copy**  from the menu or press **Ctrl + C**. The cursor displays the Copy/Paste icon.
3. Drag an edit handle:



- Drag the Move edit handle to position the copy at a new location.
- Drag a corner handle to create a copy in the same location but with a different size or shape. The result depends on which **Edit Behavior**  you use. See “Edit Behaviors” on page 120.

 Use the Concentric edit behavior to create concentric copies of CAD-based objects. See “To create setback lines” on page 199 of the User’s Guide for an example.

4. You can resize or position the copy accurately with respect to the original by watching the moved distance in the Status Bar at the bottom of the screen.

Sticky Mode

 Normally, after an action is performed using the edit tools or handles while in an edit mode such as Paste mode, you return to the Main Edit Mode. Click the **Sticky Mode** edit button to remain in Paste mode and continue pasting copies of the selected object(s).

To exit Paste mode and return to the main edit toolbar for the selected object, click the **Main Edit Mode**  edit button or press the Esc key on your keyboard. If you have not pasted a copy of the selected object and immediately click **Copy/Paste**  after returning to the Main Edit Mode, **Sticky Mode**  is still enabled.

 Sticky Mode is available when the Copy/Paste edit button is clicked.

Copy and Paste in Place



Click the **Copy and Paste in Place** edit button to create a copy of the selected object(s) at the same location as the original. The copy remains selected so you can perform additional operations.



Because multiple walls, railing and fencing cannot share the same space, the **Copy and Paste in Place**  edit button is not available for these objects.

Paste Hold Position



When copying between different floors or view windows, you can paste a copy at the same absolute position as the original selection using **Paste Hold Position**.

To use Paste Hold Position

1. Select the object(s) to be copied.
2. Click the **Copy/Paste**  edit button.
3. Switch to the desired floor or plan file and select **Edit> Paste> Paste Hold Position** .
4. A copy is placed at the same X, Y coordinates on the new floor or in the new plan as the original's position.

Paste Special



The **Paste Special** tool allows you to choose a representation for the selection to be pasted.

Selections can be pasted as:

- Enhanced Windows Metafiles (EMF). See “Metafiles” on page 814.

- Device Independent Bitmaps (BMP). See “Importing Pictures” on page 812.
- Unformatted non-unicode text (TXT).
- File Name (a path to a file). Depending on the file type, it will be either opened or imported (if supported).
- Unformatted text (HTML). Pastes as text.
- Model Objects - Home Designer Pro format, not compatible with other programs.

To use Paste Special

1. Select an object, image, text or file on your computer and copy it.
2. Switch to the desired Home Designer Pro view window and select **Edit> Paste> Paste Special** .
3. In the **Paste Special** dialog, select the desired representation for the selection and click OK.
4. Click in the drawing area to place the copy at that location.

Using the Transform/Replicate Object Dialog



Objects and groups of objects can be copied and pasted using the **Transform Replicate Object** dialog. See “Transform/Replicate Object Dialog” on page 166.

Copy Region as Picture



The **Copy Region as Picture** tool allows you to copy any portion of the screen and save it as a picture. See “Copy Region as Picture” on page 819.



Using Point to Point Move



The **Point to Point Move** edit button can be used in combination with

Copy/Paste  to make a copy of the selected object(s) at a specified location. See “Point to Point Move” on page 153.

To point to point copy



1. Select the object(s) to be copied, click the **Copy/Paste**  edit button, then the **Point to Point Move**  edit button.
2. Click at the start point and then at the end point.

3. An exact copy of the selected object(s) is created at the end point while the original remains unchanged.

Using Reflect About Object



The **Reflect About Object** edit button can be used in combination with

Copy/Paste  to make a reflected copy of the selected object(s), much the way **Point to Point Move**  can. See “Reflect About Object” on page 163.

Editing Objects

Just as the methods used to create different objects in Home Designer Pro are similar, the options for moving, rotating, resizing, and otherwise editing them are also alike.

Edit handles allow objects to be resized, relocated, or rotated using the mouse. Edit toolbar buttons and the contextual menus access edit tools relevant to the selected object(s). Most objects have a specification dialog that allows you to edit it in ways that are specific to that type of object.

The editing characteristics common to most objects are described in this chapter. Unique, object-specific editing behaviors and the specification dialogs are covered in their respective chapters.

Chapter Contents

- Defaults and Preferences
- Edit Behaviors
- Selecting Objects
- Editing Line Based Objects
- Editing Arc Based Objects
- Editing Open Polyline Based Objects
- Editing Closed-Polyline Based Objects
- Editing Box-Based Objects
- Editing Spline Based Objects
- Editing Circles, Ovals and Ellipses
- Displaying Objects
- Moving Objects
- Aligning Objects
- Resizing Objects
- Reshaping Objects
- Rotating Objects
- Reflecting Objects
- Converting Objects
- Transform/Replicate Object Dialog
- Edit Area Tools
- Deleting Objects
- Undo and Redo

Defaults and Preferences

The same defaults and preference settings that affect how objects are drawn also influence how they can be edited. See “Defaults and Preferences” on page 108.



It is a good idea to be familiar with these options and how they affect drawing and editing in the program.

Edit Behaviors



There are five **Edit Behavior** modes that determine how edit handles affect an object, and may also affect how objects are drawn. The currently active edit behavior is a global preference setting, affecting all plan and layout files.

Two of these modes, **Default** and **Alternate**, are useful for most drawing and editing needs and can be considered primary editing modes. Default mode, in particular, accesses the most commonly used behaviors and is the best choice in most circumstances. When an Edit Behavior other than Default is active, its icon displays near the mouse pointer.

Note: Regardless of which Edit Behavior is active, the Default behavior is restored when you close the program.

The other three modes, **Resize**, **Concentric** and **Fillet**, offer special editing behaviors that may be useful only in certain situations and can be considered secondary.

Each edit behavior can be temporarily enabled using the different buttons on your mouse or by pressing the keyboard keys associated with each. See “Using the Mouse” on page 26 and “Hotkeys” on page 99.

You can also specify which edit behavior mode is active when the left mouse button is used in the **Preferences** dialog, by selecting **Edit > Edit Behaviors** , or by clicking the corresponding toggle button, which can be added to your toolbar. See “Behaviors Panel” on page 78.

Default



The **Default** mode is one of the primary edit behavior modes. It offers access to the most commonly used edit behaviors and should be selected as your preference in most situations.



When the use of a tool is described in this manual, it is assumed that the Default edit behavior mode is active.

- **Drawing** - Standard click and drag drawing behavior is enabled. See “Creating Objects” on page 112.
- **Resize/Reshape** - Default allows you to adjust the angle of any corner of a poly-line without affecting adjacent corners, changing the object’s shape.

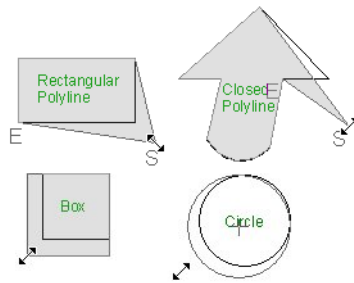

Default edit behavior

- For box-based objects, the Default mode functions the same as the Alternate mode.
- **Movement** - Default allows you to move objects orthogonal, or at a right angle, to any of their edges.
- **Rotation** - In Default mode, objects snap at Allowed Angles as they are rotated.

You can temporarily enable the **Default**  edit mode when another mode is active by pressing **Alt + Z** or **Alt + /** while performing an edit or drawing operation.

Alternate

 The **Alternate** mode is the second primary edit behavior mode. When this mode is active, the Alternate **Alt** icon displays near the mouse pointer.



Note: Not all commands have an Alternate edit behavior. If a selected tool does not, it will not work when this edit mode is active.

- Alternate allows you to drag an end handle on an open polyline to change it from a line to an arc or vice versa.
- Alternate overrides the **Lock Center** setting of arc-based objects.

- **Movement** - Alternate allows you to move objects at Allowed Angles when **Angle Snaps**  are enabled, or orthogonal to any of its edges when they are not. See “Angle Snaps” on page 111.
- **Rotation** - Alternate snaps objects at Allowed Angles as they are rotated.

You can temporarily enable the **Alternate**  edit mode when another mode is active by pressing **Alt** or using the right mouse button while performing an edit operation.

Resize

 The **Resize** edit behavior allows you to rescale an object. As you drag a corner edit handle of an object, you get an exactly scaled version of the original. For example, you can resize an object to 50% of its original size while maintaining the same proportions. When this mode is active, the **Resize**  icon displays near the mouse pointer.

- **Drawing** - Standard click and drag drawing behavior is enabled.
- **Resize/Reshape** - Resize allows you to keep the angle between adjacent edges fixed when a corner handle is moved.

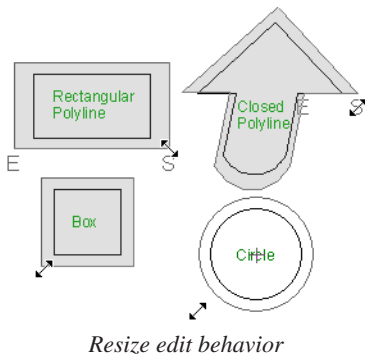



 To proportionally resize an object, always drag a corner edit handle and not an edge handle.

- **Movement** - Resize allows you to move an object orthogonal, or at a right angle, to any of its edges.
- **Rotation** - In Resize Mode, objects snap at Allowed Angles as they are rotated.

You can temporarily enable the **Resize**  edit mode when another mode is active by pressing **X** or the period key, or using the X2 button on a five-button mouse while performing an edit or drawing operation. See “Using the Mouse” on page 26.

Concentric

 The **Concentric** mode allows you to resize objects so that the distance moved by each edge is the same. For example, you can resize an irregularly shaped polyline so that each edge is exactly ten feet in from the original position, which is useful for creating site plans with setbacks.

When this mode is active, the Concentric  icon displays near the mouse pointer.

- **Drawing** - Standard click and drag drawing behavior is enabled.
- **Resize/Reshape** - Concentric allows you to resize an irregularly-shaped polyline so that each edge is moved the same distance from its original location.

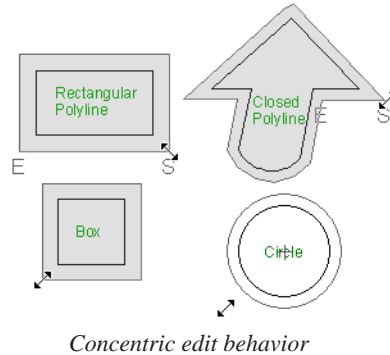

Note: The Concentric edit behavior can be used to create concentric copies of CAD-based objects. See “To create setback lines” on page 199 of the User’s Guide.

- Concentric mode also allows you to move opposite edges of an object so that each edge is moved the same distance from its original location.

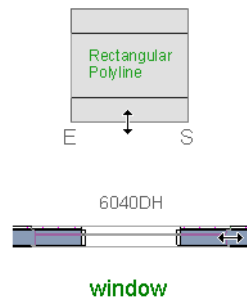

- **Movement** - Concentric mode allows you to move an object orthogonal, or at a right angle, to any of its edges.
- **Rotation** - In Concentric mode, objects snap at Allowed Angles as they are rotated.

In some cases, the Concentric and Resize edit behaviors have the same result, such as when a circle is resized. Usually, though, the two behaviors are different because concentric resizing does not maintain the original ratio between an irregular polyline's edges.

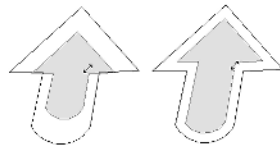

Resize edit behavior *Concentric edit behavior*

In Concentric mode, objects resize in **Concentric Jump** increments specified in the **Preferences** dialog. See “Behaviors Panel” on page 78.

When the **Concentric Jump** distance is set at 0”, objects resize according to the **Snap Unit** specified in the **Plan Defaults** dialog. See “Grid Snaps” on page 112.



 To concentrically resize an object with no restrictions, set the Concentric Jump value on the Edit> Behaviors panel of the Preferences dialog to zero and turn off Grid Snaps.

You can temporarily enable the

Concentric  edit mode when another mode is active by pressing **C** or the command

key, or using the X1 button on a five-button mouse while performing an edit or drawing operation. See “Using the Mouse” on page 26.

Fillet

 The **Fillet** mode allows you to add a fillet, or curve, at any corner of an object. Dragging a corner edit handle adjusts the fillet radius at that corner. When this mode is active, the Fillet  icon displays near the mouse pointer.

- **Drawing** - Standard click and drag drawing behavior is enabled.
- **Resize/Reshape** - Fillet allows you to create a fillet at by dragging a corner edit handle inward.

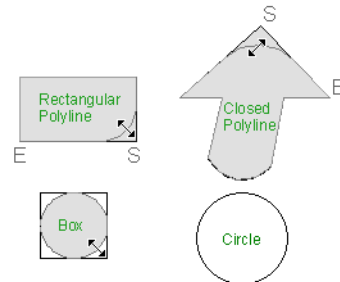

Fillet edit behavior

- **Movement** - Move mode allows you to move objects at Allowed Angles.
- **Rotation** - In Move mode, objects snap at Allowed Angles as they are rotated.

The **Fillet**  edit behavior adjusts all the corners of a box at once. The radius of each corner is the same.

Fillet  does not have an effect on circles, ovals, ellipses or arc segments.

You can temporarily enable the **Fillet**  edit mode when another mode is active by pressing **F** while performing an edit or drawing operation.



To produce fillets or chamfers of an exact radius, set the Fillet Chamfer Radius and use the Fillet Two Lines or Chamfer Two Lines edit button. See “Fillet Two Lines” on page 159 and “Chamfer Two Lines” on page 160.

Selecting Objects

“Select” refers to selecting an object for editing. An object must be selected before it can be edited.

In order for an object to be selected, it must be both unlocked and visible in the current view. See “Layers” on page 101.

When an object is selected, it displays edit handles and a selection fill color. See “Colors Panel” on page 63.

In 3D views, a selected object will also display lines representing the selected edge or surface. The size of the edit handles does not change as you zoom in or out and is set in the **Preferences** dialog. See “Edit Panel” on page 76. To prevent them from stacking on one another, some edit handles may not display as you zoom away from the selected object.

When an object is selected, its edit toolbar also displays, typically at the bottom of the Home Designer Pro program window just above the Status Bar. See “The Edit Toolbar” on page 29.

Information about the selected object or objects may also display in the Status Bar. See “The Status Bar” on page 31.

A selected object remains selected until another object is selected, a different tool is

activated, the Esc key on the keyboard is pressed, or any two mouse buttons are pressed at the same time.

Select Objects



With the exception of temporary CAD points, any object created using Home Designer Pro can be selected using the **Select Objects** tool. Select **Edit> Select Objects**, click the toolbar button or press the **Space** bar on your keyboard to activate this tool, then click on an object to select it.

You can also select objects or open context sensitive menus using the right mouse button when any tool is active.

By default, you can select an object by clicking within 12 pixels of it. You can adjust this distance by changing the **Snap Distance** in the **Preferences** dialog. A lower value, for example, can be helpful for working with small objects but can also make it very difficult to select larger objects. See “Snap Properties Panel” on page 79.

Selecting Similar Objects

If a tool other than **Select Objects**  is active, you can only select objects of that type using the left mouse button. For

example, if the **Straight Exterior Wall**  tool is active, you can only select walls using the left mouse button.

This can be useful for selecting an object when many objects of a different type occupy the same space in floor plan view.

Objects can be selected using the right mouse button, regardless of which tool is active.

Right-Clicking

Regardless of which tool is active, you can select an eligible object by right-clicking on it once. When you right-click to select an object a contextual menu also appears, displaying the object's edit tools. You can turn contextual menus on or off in the **Preferences** dialog. See “Contextual Menus” on page 30.

If a drawing tool is active and you right-click to select an object, you can unselect it by left-clicking in an empty space in the drawing area. Although a drawing tool is active, it is not used. If you then left-click a second time, the active tool will be used.

Selected Edge

When you click on a polyline- or box-based object, the edge that you click nearest becomes the selected edge and displays an edit handle larger than those on other edges. The handle on this edge may also display at the point where you clicked to select it.

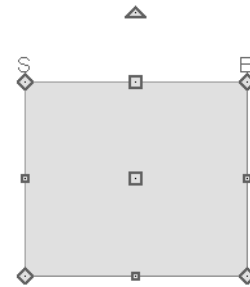

Selected edge with start and end indicators

This edge can be edited on the Selected Line or Selected Arc tab of the object's specification dialog, as well as using a variety of edit toolbar buttons. It can also be moved using dimensions. See “Moving Objects Using Dimensions” on page 737, “Line Tab” on page 780 and “Arc Tab” on page 787.

The Start and End points of a CAD-based object's selected edge or of a wall can be indicated by an S and an E when the object is selected. These Start and End indicators can be helpful when editing the selected edge in the object's specification dialog, and their display can be turned on and off in the **Preferences** dialog. See “Edit Panel” on page 76.

Edit Object Parts



Polyline-based objects are composed of lines and arcs that are connected end to end. The individual edges of open and closed polylines can be selected and edited independently of the object's other edges when **Edit Object Parts** is enabled.



Select **Edit**> **Edit Behaviors**> **Edit Object Parts**  to enable or disable the ability to

edit polyline segments individually. **Edit**

Object Parts  can also be turned on or off in the **Preferences** dialog. See “CAD Panel” on page 74.

Edit Object Parts  also affects connections between walls, railings and fences, but does not affect Walkthrough Paths or closed polyline CAD-based objects such as slabs and roof planes.

To use Edit Object Parts

1. Turn on **Edit Object Parts** . Your cursor will display the Edit Object Parts  icon.
2. Click on an individual edge of a polyline, or a segment of wall, railing or terrain path to select it.

A selected Terrain Wall

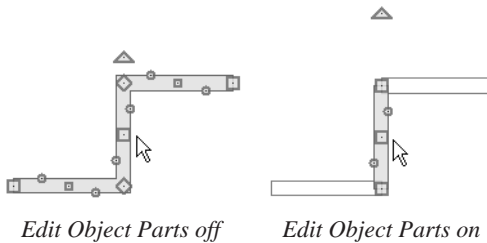

3. Notice that it is no longer connected to the rest of the polyline or adjacent walls.
4. The individual segment can now be edited entirely independent of its neighbors.
5. To connect the segment to the polyline again, turn off **Edit Object Parts**  and move the end handles so that they snap to the ends of adjacent segments.

When **Edit Object Parts**  is enabled, only objects that you click on are actually affected by it. Any objects that you do not select remain intact.

Note: Edit Object Parts is always reset to be off when you close the program.

Select Next Object

 If there is more than one object in a particular space, it may be difficult to select the desired object. When a nearby object is selected, click the **Select Next Object** edit button or press the Tab key until the desired object becomes selected. This function cannot be applied to groups of selected objects.

Marquee Select

Groups of objects can be selected by holding down either the Shift or Ctrl key when the **Select Objects**  tool is active and then dragging a marquee around the objects to be selected.

You can specify whether objects must be totally contained in or intersected by the marquee, or whether an object's center point must be contained in the marquee, in the **Preferences** dialog or using the **Selection Mode**  buttons, which can be added to your toolbars. See “Edit Panel” on page 76.

If an object is currently selected and a selection marquee is drawn around it, that object becomes de-selected. If an object is currently selected and a marquee is drawn around other objects, the original object remains selected and the other objects are added to the selection set.

When using the marquee-select method, both CAD and architectural objects included in the marquee are selected. To remove an object from the selection set, hold down the Shift key and click it.

The Shift key can also be used to marquee-select objects of a similar type. For example, click the **Hinged Door**  child button, hold down the Shift key, drag a marquee, release the mouse button, and only door objects within the marquee are selected. The Ctrl key will always marquee-select objects of all types, regardless of the active tool.



To make marquee selection easier, you can turn off the display of objects you do not want to include in your selection set. See “Displaying Objects” on page 102.

Shift Select

You can select a group of objects by adding them to the selection set one by one. Select an object, hold down either the Shift or Ctrl key, and click additional objects to select them.

More than one type of object can be selected using this method, but the ability to edit the group-selected items is limited to attributes that all selected objects have in common.

To remove an object from a selection set, click it once more - again, with either the Shift or Ctrl key pressed.

Edit Area Tools



The **Edit Area Tools** allow you to define an area of your plan and select the objects within that area for editing. See “Edit Area Tools” on page 168.

Editing Line Based Objects

Objects are considered line-based when they can be edited similar to CAD lines using their edit handles.

CAD lines, framing members, straight walls and railings, straight stairs and straight roads are examples of line-based objects.

Most line-based objects can be connected to other like objects to form polylines or polyline-based objects. See “Editing Open Polyline Based Objects” on page 134 and “Editing Closed-Polyline Based Objects” on page 138.

Some objects, notably walls, have line-based editing behavior only when selected on

certain surfaces. See “Editing Walls” on page 197.

Wall openings such as doors and windows have line-based editing behavior in floor plan view only but cannot be rotated, reversed or converted to an arc. See “Editing Doors” on page 258 and “Editing Windows” on page 289.

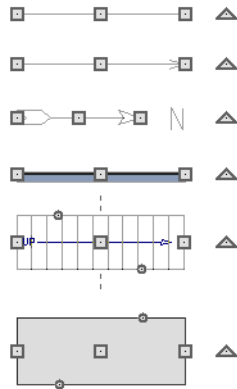

Other objects, such as stairs and roads, have additional edit handles that allow you to concentrically adjust the object's width.

Using the Edit Handles

When selected, a typical line-based object displays four edit handles.

Any action performed using the edit handles can be cancelled by pressing the Esc key or any two mouse buttons at the same time.

 The behavior of the edit handles may depend on the currently active Edit Behavior. See "Edit Behaviors" on page 120.

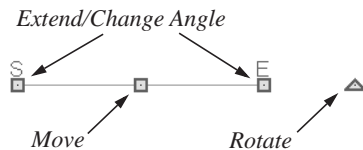

Move

- Click and drag the Move handle to move the object according to the currently

active **Edit Behavior** . See "Edit Behaviors" on page 120.

- Movement may be limited or stopped by other objects or Snap Behaviors. Move restrictions can be overridden by holding down the Ctrl key while dragging. See "Unrestricted Movement" on page 153.

Rotate

- The **Rotate** handle is used to rotate the object, either about its center or about the current CAD point. See "Rotating Objects" on page 161.

Extend/Change Angle

- Drag an end handle parallel to the selected line to change its length.
- Drag an end handle at an angle to the selected line to change its angle. When **Angle Snaps**  are on, the line snaps to Allowed Angles. See "Angle Snaps" on page 111.
- Right-click and drag it to change the adjacent line into an arc, or vice versa. See "Alternate" on page 121.

Adjust Width

Some line-based objects, such as stairs and roads, have additional handles that allow the width of the object to be adjusted.

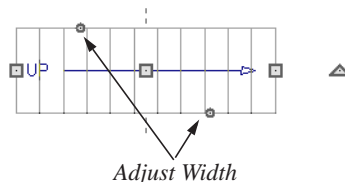

- Click and drag a small, round **Expand** handle to increase or decrease the

object's width. By default, objects are resized in 1" increments. This Snap Unit is defined in the **Plan Defaults** dialog. See "General Plan Defaults Dialog" on page 58.

Using Dimensions

 Dimensions can be used to position line-based objects relative to other objects. See "Moving Objects Using Dimensions" on page 737.

Dimensions cannot, however, be used to adjust the length of line-based objects, or the width of line-based objects such as stairs.











Using the Specification Dialog









 Line-based objects can be edited using their specification dialogs. See "Line Specification Dialog" on page 780.

Using the Edit Toolbar

A selected line-based object can be edited in a variety of ways using the buttons on the edit toolbar.

The following toolbar buttons may display on the edit toolbar for a selected line-based object:

- Click the **Select Next Object**  edit button to select nearby objects instead of the selected object. See "Selecting Objects" on page 124.
- Click the **Open Object**  edit button to open the specification dialog for the selected object(s). See "Specification Dialogs" on page 31.
- Click the **Copy/Paste**  edit button to copy the selected object(s) to the Windows Clipboard so they can be pasted elsewhere. See "Copying and Pasting Objects" on page 114.
- Click the **Copy and Paste in Place**  edit button to create a copy of the selected object(s) at the same location as the original. See "Copy and Paste in Place" on page 117.
- Click the **Delete**  edit button to delete the selected object(s). See "Deleting Objects" on page 171.
- Click the **Transform/Replicate Object**  edit button to copy, move, rotate, resize, or reflect the selected object(s). See "Transform/Replicate Object Dialog" on page 166.
- Click the **Accurate Move**  edit button to slow down the mouse speed when using the edit handles. See "Accurate Move" on page 153.
- Click the **Make Parallel/Perpendicular**  edit button to make the selected object(s) parallel or perpendicular to a straight edge. See "Using Make Parallel/Perpendicular" on page 155.
- Click the **Point to Point Move**  edit button to accurately move the selected object(s). See "Point to Point Move" on page 153.
- Click the **Center Object**  edit button to center an object along along a wall within a room or relative to a cabinet fixture. See "Using Center Object" on page 156.

- Click the **Reflect About Object**  edit button to reflect the selected object(s) about another object. See “Reflecting Objects” on page 163.
- Click the **Move to Front of Group**  edit button to display the selected object in front of other objects in the same drawing group. See “Move to Front of Group” on page 151.
- Click the **Break Line**  edit button to add a new corner or pivot point to the selected object. See “Break Line” on page 158.
- Click the **Reverse Direction**  edit button to reverse the direction of the selected object(s). See “Reverse Direction” on page 164.
- Click the **Convert Polyline**  edit button to convert the object into a special polyline-based object. See “Convert Polyline” on page 165.
- Click the **Change Line/Arc**  edit button to change a line-based object to an arc, or vice versa. See “Change Line/Arc” on page 159.
- Click the **Fillet Two Lines**  edit button, then click on a non-parallel line or arc to create an additional arc connecting the two. See “Fillet Two Lines” on page 159.
- Click the **Chamfer Two Lines**  edit button, then click an edge adjacent to the selected edge to chamfer the corner between them. See “Chamfer Two Lines” on page 160.

Editing Arc Based Objects

Objects are considered arc-based when they can be edited similar to CAD arcs using their edit handles.

CAD arcs, curved walls and railings, curved stairs, and curved roads are examples of arc-based objects.

Most arc-based objects can be connected to other like objects to form polylines or polyline-based objects. See “Editing Open Polyline Based Objects” on page 134 and “Editing Closed-Polyline Based Objects” on page 138.

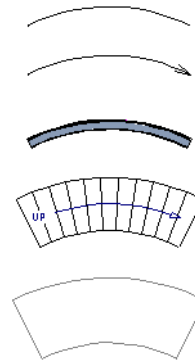

Some objects, notably curved walls, have arc-based editing behavior only when selected on certain surfaces. See “Editing Walls” on page 197.

Other objects, such as curved stairs and roads, have additional edit handles that allow you to concentrically adjust the object's width.

The currently active **Arc Creation Mode**  determines how an arc-based object is drawn. Once an arc is drawn, the active Arc Creation Mode does not affect it. See "Drawing Arcs - Arc Creation Modes" on page 784.

Using the Edit Handles

When selected, a typical arc-based object displays seven edit handles.

Any action performed using the edit handles can be cancelled by pressing the Esc key or any two mouse buttons at the same time.

 The behavior of the edit handles may depend on the currently active Edit Behavior. See "Edit Behaviors" on page 120.

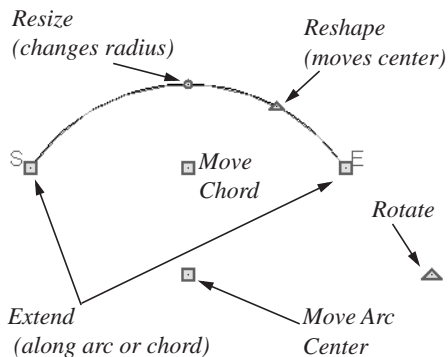

Move

- Two Move edit handles allow the arc to be relocated without changing its shape.

- One is located at the center of the chord and the other, at the arc center.
- If you would like to snap one of these center points to another point, use that handle when moving the arc. See "Aligning Arc Centers" on page 156.
- Click and drag the Move handle to move the object according to the currently active **Edit Behavior** . See "Edit Behaviors" on page 120.
- Movement may be limited or stopped by other objects or Snap Behaviors. Move restrictions can be overridden by holding down the Ctrl key while dragging. See "Unrestricted Movement" on page 153.

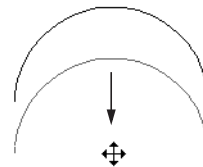

Move edit handle

Rotate

- The **Rotate** handle is used to rotate the arc, either about its center or about the current CAD point. See "Rotating Objects" on page 161.

Extend

- The end edit handles expand or contract the arc when moved along the arc radius or chord.
- If you follow the path of the arc, the end edit handles allow you to adjust the arc length.
- The angle formed by the center point of the arc and its two endpoints is referred to as the **Included Angle**. If **Angle**

Snaps  are on, the Included Angle of the arc, as measured in degrees, can be rotated at Allowed Angles. See “Angle Snaps” on page 111.

- Right-click and drag it to change the adjacent arc into a line, or vice versa. See “Alternate” on page 121.

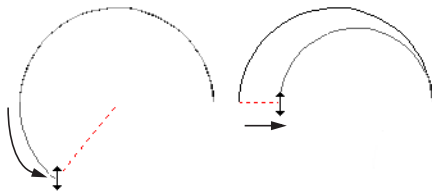

Extend edit handles

Resize

- Drag the small, round **Resize** edit handle to change the radius and included angle of the arc while maintaining its center.

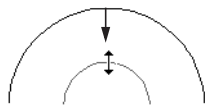

Resize edit handle

Reshape

- Drag the small triangular **Reshape** handle to change the length and location of the center without moving the endpoints.

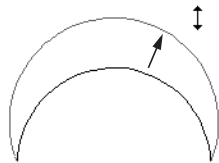

Reshape edit handle

Adjust Width

Some arc-based objects, such as stairs, have additional handles that allow the width of the object to be adjusted.

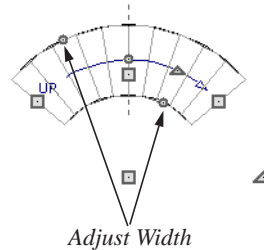

- Click and drag a small, round edit handle to increase or decrease the object’s width. By default, objects are resized according to the Snap Unit defined in the **Plan Defaults** dialog. See “General Plan Defaults Dialog” on page 58.

Using Dimensions

 Dimensions can be used to position arc-based objects. Dimension lines typically locate tangent extension lines and any extension lines that may be parallel to those lines rather than the arc itself. See “Moving Objects Using Dimensions” on page 737.















Using the Specification Dialog



 Arc-based objects can be edited using their specification dialogs. See “Arc Specification Dialog” on page 786.

Using the Edit Toolbar

A selected arc-based object can be edited in a variety of ways using the buttons on the edit toolbar.

The following toolbar buttons may display on the edit toolbar for a selected arc-based object:

- Click the **Select Next Object**  edit button to select nearby objects instead of the selected object. See “Selecting Objects” on page 124.
- Click the **Open Object**  edit button to open the specification dialog for the selected object(s). See “Specification Dialogs” on page 31.
- Click the **Copy/Paste**  edit button to copy the selected object(s) to the Windows Clipboard so they can be pasted elsewhere. See “Copying and Pasting Objects” on page 114.
- Click the **Copy and Paste in Place**  edit button to create a copy of the selected object(s) at the same location as the original. See “Copy and Paste in Place” on page 117.
- Click the **Delete**  edit button to delete the selected object(s). See “Deleting Objects” on page 171.
- Click the **Transform/Replicate Object**  edit button to copy, move, rotate, resize, or reflect the selected object(s). See “Transform/Replicate Object Dialog” on page 166.
- Click the **Accurate Move**  edit button to slow down the mouse speed when using the edit handles. See “Accurate Move” on page 153.
- Click the **Point to Point Move**  edit button to accurately move the selected object(s). See “Point to Point Move” on page 153.
- Click the **Center Object**  edit button to center an object along a wall within a room or relative to a cabinet fixture. See “Using Center Object” on page 156.
- Click the **Reflect About Object**  edit button to reflect the selected object(s) about another object. See “Reflecting Objects” on page 163.
- Click the **Move to Front of Group**  edit button to display the selected object in front of other objects in the same drawing group. See “Move to Front of Group” on page 151.
- Click the **Break Line**  edit button to add a new corner or pivot point to the selected object. See “Break Line” on page 158.
- Click the **Reverse Direction**  edit button to reverse the direction of the selected object(s). See “Reverse Direction” on page 164.
- Click the **Convert Polyline**  edit button to convert the object into a special polyline-based object. See “Convert Polyline” on page 165.
- Click the **Change Line/Arc**  edit button to change an arc-based object to a line, or vice versa. See “Change Line/Arc” on page 159.

- Click the **Fillet Two Lines**  edit button, then click on a non-parallel line or arc to create an additional arc connecting the two. See “Fillet Two Lines” on page 159.
- Click the **Chamfer Two Lines**  edit button, then click an edge adjacent to the selected edge to chamfer the corner between them. See “Chamfer Two Lines” on page 160.

Show Arc Centers

 When working with arc-based objects or circles, it can be helpful to see their center points. Click the **Show Arc Centers and Ends** toggle button on the utility toolbar to turn on their display. You can also turn on their display in the **CAD Defaults** dialog. See “CAD Defaults Dialog” on page 770.

Arc-based objects can be aligned using their center points. See “Aligning Arc Centers” on page 156.

Editing Open Polyline Based Objects

Open polyline-based objects are composed of individual line- and arc-based objects that are connected at their end points but do not form an enclosed area. See “Polylines” on page 790.

Objects are considered open polyline-based when they can be edited similar to open CAD polylines using their edit handles.

Open CAD polylines, connected walls, stairs, and roads are examples of open polyline-based objects.

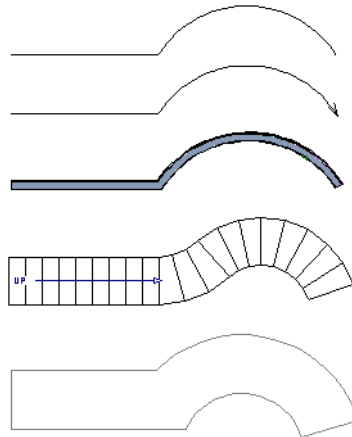

Other objects, such as connected stair and road segments, have additional edit handles that allow you to concentrically adjust the width of all segments of the object.



If Edit Object Parts is enabled, clicking on a CAD polyline edge selects the individual edge rather than the entire polyline. See “Edit Object Parts” on page 125.

Using the Edit Handles

A polyline can be composed of many segments. See “Polylines” on page 790.

When selected, an open polyline-based object displays a Move handle, a Rotate handle, a Reshape handle at the intersection of each segment, and an Extend handle at each end.

Each straight, line-based segment also has a Move edit handle along its length.

Each curved, arc-based segment has its own Move handle at the center of its chord, a Resize handle and, if it has an unlocked center, a Reshape handle. See “Editing Arc Based Objects” on page 130.

When a polyline is selected, the edge that you click nearest is called the selected edge, and certain operations affect only this edge. The Move handle of the selected edge is larger than that of other edges. It displays along the length of a line segment, or at the center of the chord on an arc segment. See “Selected Edge” on page 125.

Any action performed using the edit handles can be cancelled by pressing the Esc key or any two mouse buttons at the same time.



The behavior of the edit handles depends on the currently active Edit Behavior. See “Edit Behaviors” on page 120.

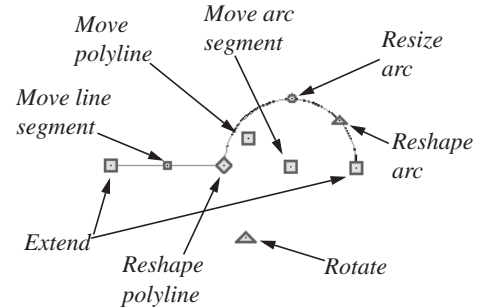

Move

- Click and drag the Move handle to move the object according to the currently active **Edit Behavior** .
- Movement may be limited or stopped by other objects or Snap Behaviors. Move restrictions can be overridden by holding down the Ctrl key while dragging. See “Unrestricted Movement” on page 153.

Rotate

- The **Rotate** handle is used to rotate the object, either about its center or about the current CAD point. Its position varies depending on which edge is currently selected. See “Rotating Objects” on page 161.

Extend

- Click and drag an Extend handle to lengthen or shorten the unconnected end of the selected line or arc segment, or to change the radius of the selected arc. See “Editing Arc Based Objects” on page 130.
- Right-click and drag it to change the adjacent line into an arc, or vice versa. See “Alternate” on page 121.

Reshape

- Click and drag a Reshape edit handle to change the angle and/or length of the segments on either side of it, or the size of the object, depending on the currently active **Edit Behavior** .

Move Line Segment

- The **Move Line Segment** edit handle is found on straight segments of open polylines and moves the straight section according to the currently active **Edit Behavior** . Adjacent segments may extend or contract in their original directions to maintain their connections.

Move Arc

- Click and drag the Move Arc edit handle to change the radius and/or chord length or position, depending on the currently active **Edit Behavior**  and whether the arc has a locked center. Adjacent segments may extend, contract, or change angle to maintain their connections.

Resize Arc

- Click and drag the Resize Arc edit handle to change the radius, chord length and chord position of the arc segment, depending on the currently active **Edit Behavior**  and whether the arc has a locked center. Adjacent segments may extend, contract, or change angle to maintain their connections.

Reshape Arc

- Click and drag the Reshape Arc edit handle to change the radius of the arc without moving its end points. Only available if the arc has an unlocked center.

Adjust Width

Some arc-based objects, such as stairs and roads, have additional handles that allow the width of the object to be adjusted.

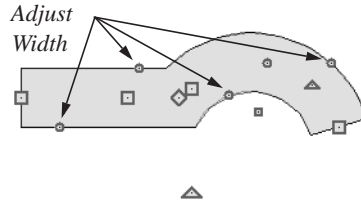

- Click and drag a small, round edit handle to increase or decrease the object's width. By default, objects are resized in 1" increments. This Snap Unit is defined in the **Plan Defaults** dialog. See "General Plan Defaults Dialog" on page 58.

Using Dimensions

 Dimensions can be used to move or reshape polyline-based objects. See "Moving Objects Using Dimensions" on page 737.

















Using the Specification Dialog





 Open polyline-based objects can be edited using their specification dialogs. See "Polyline Specification Dialog" on page 791.

Using the Edit Toolbar



A selected open polyline-based object can be edited in a variety of ways using the buttons on the edit toolbar.

The following toolbar buttons may display on the edit toolbar for a selected open polyline-based object:

- Click the **Select Next Object**  edit button to select nearby objects instead of the selected object. See “Selecting Objects” on page 124.
- Click the **Open Object**  edit button to open the specification dialog for the selected object(s). See “Specification Dialogs” on page 31.
- Click the **Copy/Paste**  edit button to copy the selected object(s) to the Windows Clipboard so they can be pasted elsewhere. See “Copying and Pasting Objects” on page 114.
- Click the **Copy and Paste in Place**  edit button to create a copy of the selected object(s) at the same location as the original. See “Copy and Paste in Place” on page 117.
- Click the **Delete**  edit button to delete the selected object(s). See “Deleting Objects” on page 171.
- Click the **Transform/Replicate Object**  edit button to copy, move, rotate, resize, or reflect the selected object(s). See “Transform/Replicate Object Dialog” on page 166.
- Click the **Accurate Move**  edit button to slow down the mouse speed when using the edit handles. See “Accurate Move” on page 153.
- Click the **Make Parallel/Perpendicular**  edit button to make the selected straight edge parallel or perpendicular to another straight edge. See “Using Make Parallel/Perpendicular” on page 155. Not available when the selected edge is an arc.
- Click the **Point to Point Move**  edit button to accurately move the selected object(s). See “Point to Point Move” on page 153.
- Click the **Center Object**  edit button to center an object along along a wall within a room or relative to a cabinet fixture. See “Using Center Object” on page 156.
- Click the **Reflect About Object**  edit button to reflect the selected object(s) about another object. See “Reflecting Objects” on page 163.
- Click the **Move to Front of Group**  edit button to display the selected object in front of other objects in the same drawing group. See “Move to Front of Group” on page 151.
- Click the **Break Line**  edit button to add a new corner or pivot point to the selected object. See “Break Line” on page 158.
- Click the **Reverse Direction**  edit button to reverse the direction of the selected object(s). See “Reverse Direction” on page 164.
- Click the **Close Polyline**  edit button to convert the selected open polyline into a closed polyline. See “Using Close Polyline” on page 138.
- Click the **Convert Polyline**  edit button to convert the object into a special polyline-based object. See “Convert Polyline” on page 165.

- Click the **Change Line/Arc**  edit button to change a line-based polyline edge to an arc, or vice versa. See “Change Line/Arc” on page 159.
- Click the **Record Walkthrough Along Path**  edit button to record a walk-through video of your model along the path defined by the selected polyline. See “Walkthroughs” on page 819.
- Click the **Fillet Two Lines**  edit button, then click on an adjacent edge to create an arc connecting the two. See “Fillet Two Lines” on page 159. Cannot be used if the adjacent edge is an arc.
- Click the **Chamfer Two Lines**  edit button, then click on an edge adjacent to the selected edge to chamfer the corner between them. See “Chamfer Two Lines” on page 160.

Using Close Polyline

 An open polyline-based object can be converted into a closed polyline using the **Close Polyline** edit tool. This tool adds an edge to the open polyline, connecting its two ends and closing the gap between them. **Close Polyline** is not available when **Edit Object Parts**  is enabled. See “Edit Object Parts” on page 125.

Editing Closed-Polyline Based Objects

Closed polyline-based objects are composed of individual line- and arc-based objects joined end-to-end and forming an enclosed area. See “Polylines” on page 790.

Objects are considered closed polyline-based when they can be edited similar to closed CAD polylines using their edit handles.

Closed CAD polylines, slabs and roof planes are examples of closed polyline-based objects.

Some objects, notably walls, have closed polyline-based editing behavior only when they are selected on certain surfaces in 3D views. See “Editing Walls” on page 197.

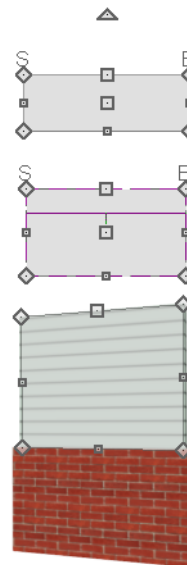

Other objects, such as connected road segments, have additional edit handles that

allow you to concentrically adjust the width of all segments of the object.

 If Edit Object Parts is enabled, clicking on a polyline edge selects the individual edge rather than the entire polyline. See “Edit Object Parts” on page 125.

Using the Edit Handles

A polyline can be composed of many segments. See “Polylines” on page 790.

When selected, a closed polyline-based object displays a Move handle, a Rotate handle, and a Reshape handle at the intersection of each segment.

Each straight, line-based segment has a Move edit handle along its length.

Each curved, arc-based segment has its own Move handle at the center of its chord, a Resize handle and, if it has an unlocked center, a Reshape handle. See “Editing Arc Based Objects” on page 130.

When a polyline is selected, the edge that you click nearest is called the selected edge, and certain operations affect only this edge. The Move handle of the selected edge is larger than that of other edges. It displays along the length of a line segment, or at the center of the chord on an arc segment. See “Selected Edge” on page 125.

Any action performed using the edit handles can be cancelled by pressing the Esc key or any two mouse buttons at the same time.

 The behavior of the edit handles may depend on the currently active Edit Behavior. See “Edit Behaviors” on page 120.

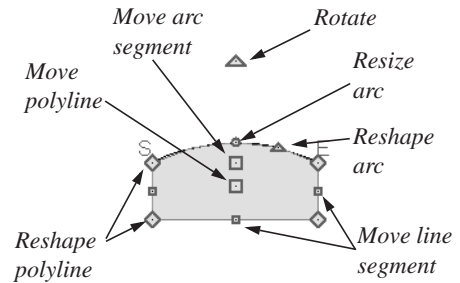

Move

- Click and drag the Move handle to move the object according to the currently active **Edit Behavior** .
- Movement may be limited or stopped by other objects or Snap Behaviors. Move restrictions can be overridden by holding down the Ctrl key while dragging. See “Unrestricted Movement” on page 153.

Rotate

- The **Rotate** handle is used to rotate the object, either about its center or about the current CAD point. Its position varies depending on which edge is currently selected. See “Rotating Objects” on page 161.

Reshape

- Click and drag a Reshape edit handle to change the angle and/or length of the segments on either side of it, or the size of the object, depending on the currently active **Edit Behavior** .

Move Line Segment

- The **Move Line Segment** edit handle is found on straight segments of closed polylines and moves the straight section according to the currently active **Edit**

Behavior . Adjacent segments may extend or contract in their original directions to maintain their connections.

Move Arc

- Click and drag the Move Arc edit handle to change the radius and/or chord length or position, depending on the currently active **Edit Behavior**  and whether the arc has a locked center. Adjacent segments may extend, contract, or change angle to maintain their connections.

Resize Arc

- Click and drag the Resize Arc edit handle to change the radius, chord length and chord position of the arc segment, depending on the currently active **Edit Behavior**  and whether the arc has a locked center. Adjacent segments may extend, contract, or change angle to maintain their connections.

Reshape Arc

- Click and drag the Reshape Arc edit handle to change the radius of the arc without moving its end points. Only available if the arc has an unlocked center.

Using Dimensions

 Dimensions can be used to move or reshape closed polyline-based objects. See “Moving Objects Using Dimensions” on page 737.

Using the Specification Dialog







 Closed polyline-based objects can be edited using their specification













dialogs. See “Polyline Specification Dialog” on page 791.

Using the Edit Toolbar

A selected closed polyline-based object can be edited in a variety of ways using the buttons on the edit toolbar.

The following toolbar buttons may display on the edit toolbar for a selected closed polyline-based object:

- Click the **Select Next Object**  edit button to select nearby objects instead of the selected object. See “Selecting Objects” on page 124.
- Click the **Open Object**  edit button to open the specification dialog for the selected object(s). See “Specification Dialogs” on page 31.
- Click the **Copy/Paste**  edit button to copy the selected object(s) to the Windows Clipboard so they can be pasted elsewhere. See “Copying and Pasting Objects” on page 114.
- Click the **Copy and Paste in Place**  edit button to create a copy of the selected object(s) at the same location as the original. See “Copy and Paste in Place” on page 117.
- Click the **Delete**  edit button to delete the selected object(s). See “Deleting Objects” on page 171.
- Click the **Transform/Replicate Object**  edit button to copy, move, rotate, resize, or reflect the selected object(s). See “Transform/Replicate Object Dialog” on page 166.

- Click the **Accurate Move**  edit button to slow down the mouse speed when using the edit handles. See “Accurate Move” on page 153.
- Click the **Make Parallel/Perpendicular**  edit button to make the selected straight edge parallel or perpendicular to another straight edge by either rotating the selected edge or the entire polyline. See “Using Make Parallel/Perpendicular” on page 155. Not available when the selected edge is an arc.
- Click the **Point to Point Move**  edit button to accurately move the selected object(s). See “Point to Point Move” on page 153.
- Click the **Center Object**  edit button to center an object along along a wall within a room or relative to a cabinet fixture. See “Using Center Object” on page 156.
- Click the **Reflect About Object**  edit button to reflect the selected object(s) about another object. See “Reflecting Objects” on page 163.
- Click the **Move to Front of Group**  edit button to display the selected object in front of other objects in the same drawing group. See “Move to Front of Group” on page 151.
- Click the **Break Line**  edit button to add a new corner or pivot point to the selected object. See “Break Line” on page 158.
- Click the **Reverse Direction**  edit button to reverse the direction of the selected object(s). See “Reverse Direction” on page 164.
- Click the **Convert Polyline**  edit button to convert the object into a special polyline-based object. See “Convert Polyline” on page 165.
- Click the **Change Line/Arc**  edit button to change a line-based polyline edge to an arc, or vice versa. See “Change Line/Arc” on page 159.
- Click the **Fillet Two Lines**  edit button, then click on an adjacent edge to create an arc connecting the two. See “Fillet Two Lines” on page 159. Cannot be used if the adjacent edge is an arc.
- Click the **Record Walkthrough Along Path**  edit button to record a walk-through video of your model along the path defined by the selected polyline. See “Walkthroughs” on page 819.
- Click the **Chamfer Two Lines**  edit button, then click an edge adjacent to the selected edge to chamfer the corner between them. See “Chamfer Two Lines” on page 160.

Editing Box-Based Objects

Objects are considered box-based when they can be edited similar to CAD boxes using

their edit handles.

Box-based objects are similar to closed polyline-based objects, but must always have four sides with right-angled corners.

In addition to the CAD Box tools, Text objects, many library symbols, pictures and images are examples of box-based objects.

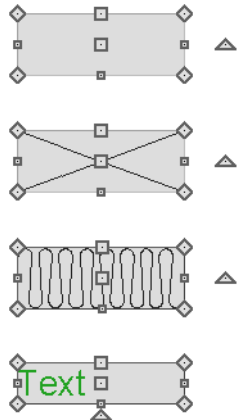



Using the Edit Handles

When selected, a box-based object displays ten edit handles. Unlike polylines, boxes must always have four sides with right-angled corners.

Any action performed using the edit handles can be cancelled by pressing the Esc key or any two mouse buttons at the same time.

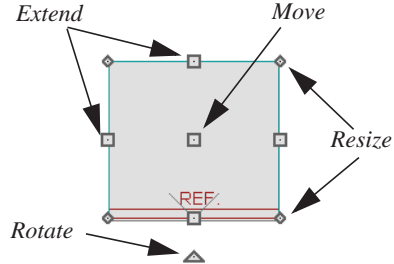
 The behavior of the edit handles may depend on the currently active Edit Behavior. See “Edit Behaviors” on page 120.



- Click and drag the Move handle to move the object according to the currently active **Edit Behavior** . See “Edit Behaviors” on page 120.
- Movement may be limited or stopped by other objects or Snap Behaviors. Move restrictions can be overridden by holding down the Ctrl key while dragging. See “Unrestricted Movement” on page 153.

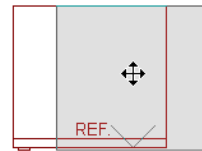

- The four **Resize** handles located at each corner are used to increase or decrease the size of the object.

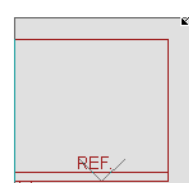

- The four **Extend** handles display along each edge. If you select an object on an edge, the Extend handle displays at the point where you clicked; otherwise, it displays at the center of the edge.

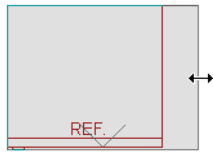

- The triangular **Rotate** handle located near the selected edge of the object is used to rotate it either about its center or the current CAD point. The pointer changes to a circular arrow  when moved over this handle. See “Rotating Objects” on page 161.

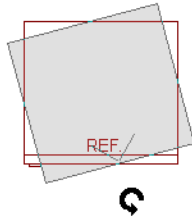

Using Dimensions

-  Dimensions can be used to move or reshape box-based objects. See “Moving Objects Using Dimensions” on page 737.









Using the Specification Dialog

-  Box-based objects can be edited using their specification dialogs. See “Box Specification Dialog” on page 795.



Using the Edit Toolbar



A selected closed polyline-based object can be edited in a variety of ways using the buttons on the edit toolbar.

The following toolbar buttons may display on the edit toolbar for a selected closed polyline-based object:

- Click the **Select Next Object**  edit button to select nearby objects instead of the selected object. See “Selecting Objects” on page 124.
- Click the **Open Object**  edit button to open the specification dialog for the selected object(s). See “Specification Dialogs” on page 31.
- Click the **Copy/Paste**  edit button to copy the selected object(s) to the Windows Clipboard so they can be pasted elsewhere. See “Copying and Pasting Objects” on page 114.
- Click the **Copy and Paste in Place**  edit button to create a copy of the selected object(s) at the same location as the original. See “Copy and Paste in Place” on page 117.
- Click the **Delete**  edit button to delete the selected object(s). See “Deleting Objects” on page 171.
- Click the **Transform/Replicate Object**  edit button to copy, move, rotate, resize, or reflect the selected object(s). See “Transform/Replicate Object Dialog” on page 166.
- Click the **Accurate Move**  edit button to slow down the mouse speed when using the edit handles. See “Accurate Move” on page 153.
- Click the **Make Parallel/Perpendicular**  edit button to make the selected straight edge parallel or perpendicular to

another straight edge. See “Using Make Parallel/Perpendicular” on page 155. Not available when the selected edge is an arc.

- Click the **Point to Point Move**  edit button to accurately move the selected object(s). See “Point to Point Move” on page 153.
- Click the **Center Object**  edit button to center an object along a wall within a room or relative to a cabinet fixture. See “Using Center Object” on page 156.

- Click the **Reflect About Object**  edit button to reflect the selected object(s) about another object. See “Reflecting Objects” on page 163.
- Click the **Move to Front of Group**  edit button to display the selected object in front of other objects in the same drawing group. See “Move to Front of Group” on page 151.
- Click the **Convert Polyline**  edit button to convert the object into a special polyline-based object. See “Convert Polyline” on page 165.

Editing Spline Based Objects

Objects are considered spline-based when they can be edited similar to CAD splines using their edit handles. See “Splines” on page 796.

Sprinkler lines, spline terrain curbs, spline terrain walls and both round and kidney-shaped terrain features are spline-based objects. See “Terrain” on page 537.



Using the Edit Handles

When a spline is selected, several different types of handles display.

Any action performed using the edit handles can be cancelled by pressing the Esc key or any two mouse buttons at the same time.

 The behavior of the edit handles may depend on the currently active Edit Behavior. See “Edit Behaviors” on page 120.

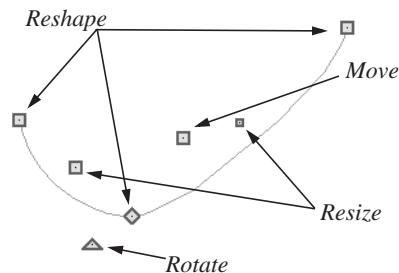

Move

- Click and drag the Move handle to move the object according to the currently

active **Edit Behavior** . See “Edit Behaviors” on page 120.

- Movement may be limited or stopped by other objects or Snap Behaviors. Move restrictions can be overridden by holding down the Ctrl key while dragging. See “Unrestricted Movement” on page 153.

Rotate

- Click and drag the Rotate edit handle to rotate the entire spline.

Reshape

- The Reshape edit handles display along the spline at each vertex. Click and drag a Reshape edit handle to change the length, angle and curve of adjacent segments without affecting other reshape handles.

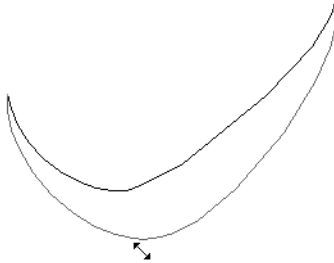

Resize

- The Resize edit handles display along the spline, between each vertex. Click and drag a Resize edit handle to move the adjacent vertices and lengthen or shorten adjacent segments.

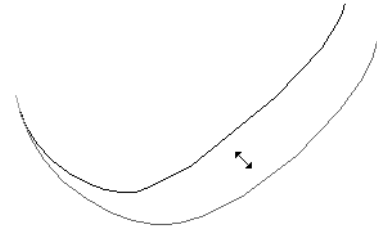



Using the Specification Dialog













 Spline-based objects can be edited using their specification dialogs. See “Polyline Specification Dialog” on page 791.

Using the Edit Toolbar

A selected spline-based object can be edited in a variety of ways using the buttons on the edit toolbar.

The following toolbar buttons may display on the edit toolbar for a selected spline-based object:

- Click the **Select Next Object**  edit button to select nearby objects instead of the selected object. See “Selecting Objects” on page 124.
- Click the **Open Object**  edit button to open the specification dialog for the selected object(s). See “Polyline Specification Dialog” on page 791.
- Click the **Copy/Paste**  edit button to copy the selected object(s) to the Windows Clipboard so they can be pasted elsewhere. See “Copying and Pasting Objects” on page 114.

- Click the **Copy and Paste in Place**  edit button to create a copy of the selected object(s) at the same location as the original. See “Copy and Paste in Place” on page 117.
- Click the **Delete**  edit button to delete the selected object(s). See “Deleting Objects” on page 171.
- Click the **Transform/Replicate Object**  edit button to copy, move, rotate, resize, or reflect the selected object(s). See “Transform/Replicate Object Dialog” on page 166.
- Click the **Accurate Move**  edit button to slow down the mouse speed when using the edit handles. See “Accurate Move” on page 153.
- Click the **Make Parallel/Perpendicular**  edit button to make the selected spline edge parallel or perpendicular to another straight edge. See “Using Make Parallel/Perpendicular” on page 155.
- Click the **Point to Point Move**  edit button to accurately move the selected object(s). See “Point to Point Move” on page 153.
- Click the **Center Object**  edit button to center an object along along a wall within a room or relative to a cabinet fixture. See “Using Center Object” on page 156.
- Click the **Reflect About Object**  edit button to reflect the selected object(s) about another object. See “Reflecting Objects” on page 163.
- Click the **Move to Front of Group**  edit button to display the selected object in front of other objects in the same drawing group. See “Move to Front of Group” on page 151.
- Click the **Break Line**  edit button to add a new corner or pivot point to the selected object. See “Break Line” on page 158.
- Click the **Convert Polyline**  edit button to convert the object into a special polyline-based object. See “Convert Polyline” on page 165.
- Click the **Record Walkthrough Along Path**  edit button to record a walk-through video of your model along the path defined by the selected polyline. See “Walkthroughs” on page 819.



Editing Circles, Ovals and Ellipses



Objects created using the **Circle Tools** are unusual in that no architectural objects share their functionalities.

Using the Edit Handles

When selected, circles, ovals and ellipses display eleven edit handles.

Unlike **Ovals**  and **Ellipses** , a **Circle**  cannot be edited into any other shapes; it can only be a circle.

Any action performed using the edit handles can be cancelled by pressing the Esc key or any two mouse buttons at the same time.

 The behavior of the edit handles may depend on the currently active Edit Behavior. See “Edit Behaviors” on page 120.

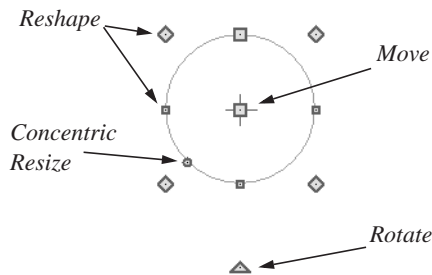

Move

- Click and drag the Move handle to move the object according to the currently active **Edit Behavior** . See “Edit Behaviors” on page 120.
- Movement may be limited or stopped by other objects or Snap Behaviors. Move restrictions can be overridden by holding down the Ctrl key while dragging. See “Unrestricted Movement” on page 153.

Rotate

- Click and drag the Rotate handle of an oval or ellipse to change its orientation.

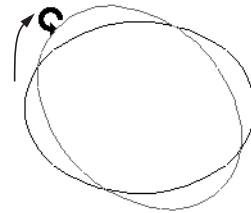

Reshape

- The eight edit handles beyond the perimeter are Reshape edit handles. Move them in or out to resize and reshape an oval or ellipse.

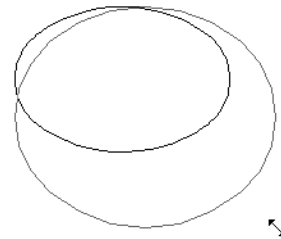

- Unlike ovals and ellipses, circles cannot be reshaped. When a Reshape handle is dragged on a circle, it is only resized.

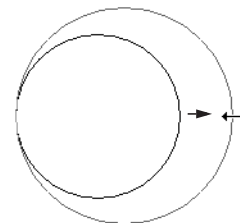

Concentric Resize

- The Concentric Resize edit handle displays on the perimeter of a circle between a corner Reshape handle and the center. Click and drag this handle to resize the circle without moving its center point.

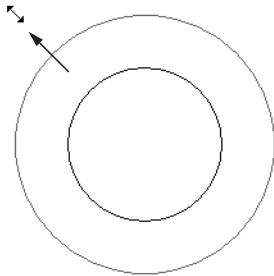

Using Dimensions



Dimensions can be used to move or resize circle-based objects. See “Moving Objects Using Dimensions” on page 737.

Using the Specification Dialog



Circles, ovals and ellipses can be edited using their specification dialogs. See “CAD Circle/Oval/Ellipse Specification Dialog” on page 789.



Using the Edit Toolbar

A selected circle, oval or ellipse can be edited in a variety of ways using the buttons on the edit toolbar.

The following toolbar buttons may display on the edit toolbar for a selected circle, oval or ellipse:

- Click the **Select Next Object** edit button to select nearby objects instead of the selected object. See “Selecting Objects” on page 124.
- Click the **Open Object** edit button to open the specification dialog for the selected object(s). See “Specification Dialogs” on page 31.
- Click the **Copy/Paste** edit button to copy the selected object(s) to the Windows Clipboard so they can be pasted elsewhere. See “Copying and Pasting Objects” on page 114.
- Click the **Copy and Paste in Place** edit button to create a copy of the selected object(s) at the same location as the original. See “Copy and Paste in Place” on page 117.
- Click the **Delete** edit button to delete the selected object(s). See “Deleting Objects” on page 171.
- Click the **Transform/Replicate Object** edit button to copy, move, rotate, resize, or reflect the selected object(s). See “Transform/Replicate Object Dialog” on page 166.
- Click the **Accurate Move** edit button to slow down the mouse speed when using the edit handles. See “Accurate Move” on page 153.
- Click the **Make Parallel/Perpendicular** edit button to make the selected edge parallel or perpendicular to another straight edge. See “Using Make Parallel/Perpendicular” on page 155.
- Click the **Point to Point Move** edit button to accurately move the selected object(s). See “Point to Point Move” on page 153.
- Click the **Center Object** edit button to center an object along along a wall within a room or relative to a cabinet

fixture. See “Using Center Object” on page 156.

- Click the **Reflect About Object**  edit button to reflect the selected object(s) about another object. See “Reflecting Objects” on page 163.
- Click the **Move to Front of Group**  edit button to display the selected object

in front of other objects in the same drawing group. See “Move to Front of Group” on page 151.

- Click the **Convert Polyline**  edit button to convert the object into a special polyline-based object. See “Convert Polyline” on page 165.

Displaying Objects

The display of objects in 2D and 3D views can be controlled by layer. See “Displaying Objects” on page 102.

Text, Line and Fill Styles

In addition to text-based objects, a variety of objects can display text as part of their line style or label. The appearance of this text can be controlled by layer. See “Line and Text Styles” on page 102.

Line style, weight and color can be controlled by layer or overridden in the specification dialogs for many objects. See “Line Style Tab” on page 781.

You can also toggle the on screen display of line weights on and off. See “Show Line Weights” on page 845.

In addition, many objects have a fill style that can be specified in the objects’ specification dialogs. See “Fill Style Tab” on page 792.

Color On/Off





The display of color on-screen can be toggled on and off in all views except perspective views by selecting **Tools> Display Settings> Color On/Off**.

You can set defaults to specify whether cross section/elevations, camera views and overviews using the Orthographic rendering technique are generated with colors turned in the **3D View Defaults** dialog. See “Options Tab” on page 669.



The display of colors may or may not make a view easier to understand. Experiment to see what works for you, then set your default in the **3D View Defaults** dialog for each view.

Colors are used in Orthographic Views to represent different materials. The colors can be printed if you have a color printer, or can appear as shades of gray on a black and white printer. If you have assigned a picture file to represent the texture of a material in perspective views, the program can sample that picture file and define an approximate color to use in all Orthographic views. See “Define Material Dialog” on page 643.

To display views in gray scale

1. Select **Tools> Display Settings> Color Off**  to toggle color off.
2. Select **Edit> Preferences**  to open the **Preferences** dialog.
3. On the Appearance panel, check **Obey Color On/Off Setting**. See “Appearance Panel” on page 61.

To display views in black and white

1. Select **Tools> Display Settings> Color Off**  to toggle color off.
2. Select **Edit> Preferences**  to open the **Preferences** dialog.
3. On the Appearance panel, uncheck **Obey Color On/Off Setting**.

When color is toggled off and **Obey Color On/Off Setting** is unchecked, all lines appear in black and solid fills appear in either white or black, depending on which is closer to the actual line or fill color when color is turned on. The background remains as defined in the **Preferences** dialog. See “Colors Panel” on page 63.

You can also print in color, black and white, or gray scale. See “Print Dialog” on page 855.

Arc Centers and Ends



The display of arc center- and endpoints, and the display of circle center points can be enabled by clicking the **Show Arc Centers and Ends** toggle button or in the **CAD Defaults** dialog. See “CAD Defaults Dialog” on page 770.

Drawing Groups

Each object in a plan or layout file belongs to one of three drawing groups, which influences whether it displays in front of or behind other objects.

- The **Default Group** is where most objects are placed when first created.
- Objects moved to the **Back Group** display behind those in the other two drawing groups.
- Objects moved to the **Front Group** display in front of those in the other two drawing groups.

Most objects are drawn in the Default Group. Notable exceptions are imported pictures, which are placed in the Back Group, and Walkthrough Paths, which are placed in the Front Group. Objects in the Default Group display in front or behind one another according to program-defined rules that can be modified in only limited ways.

Once most CAD or CAD-based objects are created, though, you can control how they display relative to other objects using their specification dialog. See “Line Style Tab” on page 781.

For example, you can move an object to the **Back Group** or **Front Group** so that it displays behind or in front of objects in the other drawing groups.

You can also check **Move to Front of Group** or use the edit button of the same name to display the object in front of other objects in its drawing group, but not necessarily in front of objects in other groups.

Move to Front of Group

 Click the **Move to Front of Group** edit button to move the selected object(s) so that it displays in front of other objects in the same drawing group. **Move to Front of Group** functions like the checkbox of the same name in the object's specification dialog.

An object moved to the front of the Default Group, for example, will display in front of objects in that group and those in the Back Group, but will still display behind objects in the Front Group.

Move to Front of Group  only affects the display of objects in the Default Group when they are of the same type: for example, CAD objects, furnishings, base cabinets, or wall cabinets. It cannot make a base cabinet display in front of a wall cabinet; but it can make a selected wall cabinet display in front of other wall cabinets.

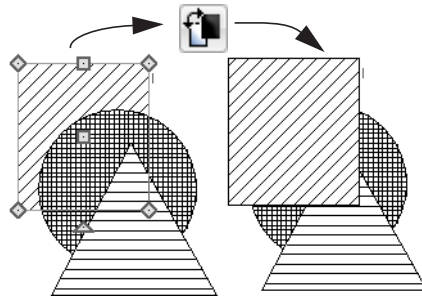

Move to Front of Group  is useful for creating a sense of depth or to improve a drawing's clarity. For example, in a cross section detail, you can move a CAD circle representing rebar to the front of a wall with

a concrete fill pattern so that the rebar is not masked by the wall's fill pattern.

Move to Front of Group  is not available for Walkthrough Paths.

Patterns and Textures

The appearance of architectural objects in 3D views is affected by the materials applied to the objects' surfaces. See "Materials" on page 631.

Material patterns display in Technical Illustration and Vector Views, while textures display in Standard rendered views. See "Rendering Techniques" on page 710.

In 3DStandard rendered views that use textures, you can turn on or off the display of textures by selecting **3D> Toggle**

Textures .

Delete Surface

 In any 3D view, select **3D> Delete Surface**, then click a surface in the view to temporarily remove the surface from the current view. See "Delete 3D Surface" on page 679.

Refresh Display

 **Refresh Display** redraws the current window to clean up extra lines, show missing items, and correct random on-screen effects caused by changes to a model. Select **Tools> Display Settings> Refresh Display** or press the F5 key to refresh the on-screen display.

Moving Objects

Objects can be moved using the edit handles as well as a variety of edit tools. Multiple selected objects can also be moved as a group. See “Selecting Objects” on page 124.

Using the Edit Handles

Select an object, then click the **Move** edit handle and drag it to a new location. When your pointer is over the Move handle, it displays a four-headed arrow.

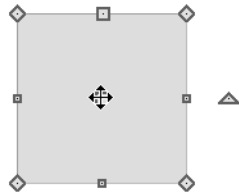



As an object is moved, it jumps at set increments when **Grid Snaps**  are enabled. See “Grid Snaps” on page 112.

When **Object Snaps**  are enabled, a selected object snaps to its original location if it passes over that location while being moved.

The behavior of the Move edit handle varies depending on the currently active **Edit**

Behavior . See “Edit Behaviors” on page 120.

- If the **Default** , **Resize** , **Concentric**  or **Fillet**  edit behavior is active, the object moves orthogonal, or at a right angle to, any of its edges.

- If the **Alternate**  edit behavior is active, the selected object(s) can be moved at Allowed Angles if **Angle Snaps**  are enabled, or orthogonal to any of its edges if they are not. See “Alternate” on page 121.

You can temporarily slow the movement of your mouse as you drag an edit handle by holding down the Shift key on your keyboard.

Bumping/Pushing

When **Edit > Snap Settings > Bumping/Pushing** is enabled, CAD and CAD-based objects with **CAD Stops Move** and/or **Wall Stops Move** enabled, as well as architectural objects, bump into and can push one another as they are moved. See “Line Style Tab” on page 781.

When an object bumps into another similar object while it is being moved, it stops. Continue dragging and the selected item resumes movement through the obstructing object. The **Maximum Bump Distance**, or the distance you must drag to override bumping, is set in the **Preferences** dialog. See “Snap Properties Panel” on page 79.

Bumping/Pushing  also affects objects when they are moved using dimensions. See “Moving Objects Using Dimensions” on page 737.

Walls, wall openings, cabinets, furnishings and fixtures, and CAD and CAD-based objects are examples of objects that can push other objects of these same types once they

have bumped into them. Instead of dragging through the obstructing object(s), release the mouse button and then click and drag the Move edit handle a second time in the same direction to push.

Certain types of objects, notably roof planes, and objects on locked layers can be bumped but cannot be pushed. See “Layer Display Options Dialog” on page 104.

CAD Stops Move/ Wall Stops Move

CAD and CAD-based objects can be set to stop at other CAD objects and/or at walls as they are being moved. See “Line Style Tab” on page 781.

Some objects, such as cross boxes, framing members and insulation, are automatically set to stop when moved against other CAD objects.

CAD Stops Move and **Wall Stops Move** do not function if **Bumping/Pushing**  is turned off.

Unrestricted Movement

Many objects have restrictions placed on their movement by their own properties or specification settings. Architectural objects, for example, bump into other 3D objects as they are being moved when **Bumping/**

Pushing  is enabled.

CAD-based objects may be set to stop at other CAD objects or at walls. See “Line Style Tab” on page 781.

Other move restrictions are activated by the **Snap Settings** . See “Snap Behaviors” on page 109.

These restrictions can be overridden when necessary by holding down the Ctrl key while dragging to move an object.

To move an object freely

1. Select the object.
2. Hold down the Ctrl key.
3. Click the Move edit handle and drag it to the new location.

You can also press the Ctrl key while dragging an object’s Move handle to override move restrictions.

Accurate Move



Click the **Accurate Move** edit button, then move the selected object(s) at a slower speed than normal for greater precision. **Accurate Move** can also be used to resize, reshape or rotate objects.

Accurate Move  is not a toggle button: it only affects the speed of the mouse during the next edit. The next time you want to use this edit tool, you need to click it again.

You can also slow down the movement speed of a selection after you have started moving it by pressing the Shift key. Release the Shift key to resume movement at normal speed.



Point to Point Move





The **Point to Point Move** edit button allows a selected object or group of objects to be accurately moved.

To use Point to Point Move

1. Select one or more objects that you would like to move, then click the **Point to Point Move**  edit button.
2. Click a point that you want to accurately reposition.
3. Click the point in the plan where you would like the selected point to be relocated when it is moved.
4. The selected object(s) are moved so that they maintain their position relative to the point.

Point to Point Move  can be used with the **Copy/Paste**  edit button. See “To point to point copy” on page 118.

Point to Point Move  can also be used with the **Edit Area**  tools. See “Edit Area Tools” on page 168.

Center Object

 The **Center Object** edit button allows you to move walls, cabinets and other

objects so that they are centered along a wall within a room or relative to a window or cabinet.

Move to Framing Reference

 Framing members can be positioned relative to a Framing Reference using the **Move to Framing Reference** edit tool. See “Framing Reference Marker” on page 442.

Using Dimensions

 Objects or the selected edges of some objects can be moved using dimensions. See “Moving Objects Using Dimensions” on page 737.

Using the Transform/ Replicate Object Dialog

 Objects and groups of objects can be moved relative to themselves or an absolute location using the **Transform Replicate Object** dialog. See “Transform/Replicate Object Dialog” on page 166.

Aligning Objects

It is often important to align objects such as text boxes, roof plane edges or walls, or to align objects on different floors. There are several methods to choose from.

Using the Mouse Cross Hairs

Objects can be aligned by eye using the mouse cross hairs as a reference. This

method can help you draw, place and edit objects quickly and with reasonable accuracy, but is not necessarily as accurate as some of the other approaches described here.

The mouse cross hairs can be turned on and off in the **Preferences** dialog. See “Edit Panel” on page 76.

Using Snap Settings

With **Object Snaps**  on, you can snap the edge of a selected object to that of another. Select an edge of an object. Drag it to the edge of another object to reveal an Object Snap point, then release the mouse.

With **Grid Snaps**  on and **Angle**

Snaps  off, select the left side of the object, and drag from the center move handle. This snaps the selected side to the grid.

When both **Grid Snaps**  and **Angle**

Snaps  on, objects snap at increments equal to the **Snap unit** specified in the **Plan Defaults** dialog rather than onto the grid itself. This does not align objects to the grid unless they were already snapped to the grid. See “Snap Behaviors” on page 109.

Using Dimensions

 Create a temporary or manual dimension relative to an object such as a wall or line, and relocate the objects to the same dimension. See “Moving Objects Using Dimensions” on page 737.



Text objects can be aligned using settings in the Text Specification dialog. See “Aligning Text” on page 756.

CAD Stops Move/ Wall Stops Move

CAD and CAD-based objects can be aligned using another CAD object or a wall as a guide. Check the **CAD Stops Move** and/or

Wall Stops Move boxes in the objects’ specification dialogs, then move them until they bump into the CAD object or wall that you wish to use as a guide for alignment. See “Line Style Tab” on page 781.

Using Make Parallel/ Perpendicular



The **Make Parallel/Perpendicular** edit button allows you to make a selected object parallel or perpendicular to any straight edge.

If you select an edge of a polyline-based object, adjacent edges extend or contract to maintain contact, but other edges are remain unchanged. The selected edge rotates about its endpoint if selected near the end, or about its center if you click within its middle third.

To use Make Parallel/Perpendicular

1. Select an object such as a roof plane on the edge that you would like to make parallel or perpendicular to another object.
 - Click near the center of the edge to rotate it about the center.
 - Click near an end to rotate the edge about that end.
2. Click the **Make Parallel/Perpendicular**  edit button
3. Click on a straight edge such as a wall.
4. If the first object is within 45° of parallel to the second object, it is made parallel. Otherwise, it is made perpendicular to the second object.

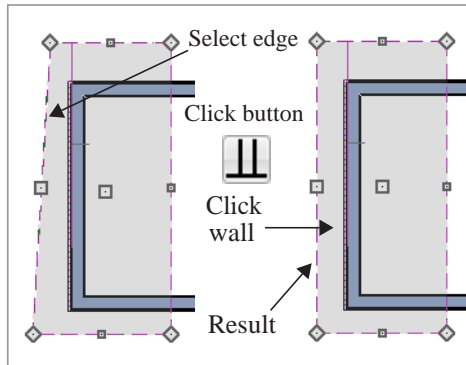

You can also make the selected edge parallel by rotating the entire object. See “Make Parallel/Perpendicular with Polyline Based Objects” on page 162.

Using Center Object



The **Center Object** edit button can be used to center a variety of objects relative to another object.

To center an object

1. Select an object.
2. Click the **Center Object**  edit button.
3. Move the mouse pointer over the object you would like to center the selected object relative to.
 - As the pointer passes over an eligible object, it becomes highlighted and a dashed centering axis line displays.
4. When the desired centering axis displays, click once to center the selected object along that axis line.



To center an object in a room

1. Select an object such as a cabinet.
2. Click the **Center Object**  edit button.
3. Move the mouse pointer in the room that you would like to center the selected object relative to.
 - As you move the pointer, a centering axis will display along the wall it is closest to.
 - The selected object does not have to be inside a room in order to be centered relative to that room.
4. When a centering axis displays along the correct wall, click once.
5. The object is moved perpendicular to the centering axis.

If you click outside an exterior wall instead of clicking inside, the selected object is centered along the edge of the Exterior Room. See “The Exterior Room” on page 232.

Aligning Arc Centers

The center points of circles and arc-based objects can be aligned, even if the objects are on different floors, when the Reference Display is turned on and **Show Arc Centers and Ends**  is enabled. See “The Reference Floor” on page 327 and “CAD Defaults Dialog” on page 770.

To align center points easily, it is helpful to turn on **Object Snaps**  and turn off **Angle Snaps** . See “Object Snaps” on page 110 and “Angle Snaps” on page 111.

Aligning Objects on Different Floors

Objects on different floors can be aligned with one another using **Object Snaps** 

and the **Reference Display** . See “Object Snaps” on page 110 and “The Reference Floor” on page 327.

Resizing Objects

Objects can be resized using the edit handles, specification dialogs, and the **Transform/Replicate Object** dialog.

holding down the Shift key on your keyboard.

Using the Edit Handles

Depending on the currently active **Edit Behavior** , the end, corner and/or side edit handles can be used to resize a selected object. See “Edit Behaviors” on page 120.

When the **Concentric**  edit behavior is active, dragging an object’s corner or end handle resizes it according to the **Concentric Jump** value set in the **Preferences** dialog. See “Concentric” on page 122.

Objects can be resized about either their center points or the current CAD point. See “Behaviors Panel” on page 78.

To override any movement restrictions caused by snap settings or the presence of other objects, press the Ctrl key while dragging an edit handle.

As an object is resized, any dimensions indicating its size will update to reflect your changes. You can use dimensions as references to help you achieve the correct size for most objects.

You can temporarily slow the movement of your mouse as you drag an edit handle by

Using the Specification Dialog

 Most objects can be accurately resized in their specification dialogs. See “Specification Dialogs” on page 31.

Using Dimensions

 Many objects can be resized by selecting an edge and then moving that edge using dimensions. See “Moving Objects Using Dimensions” on page 737.

Walls can also be resized using dimensions; however, it is important to understand that the selected edges of other objects cannot be resized using dimensions - they can only be moved. To resize an edge, select an adjacent edge and move that edge instead.

Using the Transform/Replicate Object Dialog

 Most objects can be resized about either their centers or an absolute point using the **Transform Replicate Object** dialog. See “Transform/Replicate Object Dialog” on page 166.

Reshaping Objects

There is a variety of ways to reshape objects using the edit handles, specification dialogs and edit toolbar buttons.

Some objects, notably circles and box-based objects, cannot be reshaped - only resized. See “Resizing Objects” on page 157.

Using the Edit Handles

Depending on the **Edit Behavior**  in use, the end, corner and/or side edit handles can be used to reshape a selected object. See “Edit Behaviors” on page 120.

When a line-based, arc-based, or open-polyline based object is selected, you can right-click and drag an end handle to change a line into an arc or vice versa. This behavior does not apply to closed polylines.

To override any movement restrictions caused by snap settings or the presence of other objects, press the Ctrl key while dragging an edit handle.

You can temporarily slow the movement of your mouse as you drag an edit handle by holding down the Shift key on your keyboard.

Using the Specification Dialog



A variety of CAD and CAD-based objects can be reshaped by editing values on either the Selected Line or Selected Arc tab of their specification dialogs. See “Polyline Specification Dialog” on page 791.

Using Dimensions



Both temporary and manually drawn dimensions can be used to increase or decrease the distance between the edge a line- or polyline-based object and another, parallel edge or line.

Angular Dimensions  can be used to adjust the angle where two polyline segments meet. See “Using Angular Dimensions” on page 162.

Break Line



The **Break Line** edit button can be used to break an individual line-, arc-, or spline-based object into two segments. The edges of a polyline-based object can also be broken.

Note: The Break Line edit button is not available for box-based objects, objects created with the Circle Tools, North Pointers, Sun Angles, Joist Direction Lines, or some architectural objects such as stairs and trusses.

The **Break Line**  edit tool can be used to create two types of breaks: partial breaks and complete breaks.

When a partial break is created, a new corner edit handle is placed at the location of the break. Partial breaks are also referred to as joints, nodes or pivot points.

- Click the **Break Line**  edit button to add a new corner or pivot point to the selected object.

To create a partial break

1. Click the object or edge that you want to break into two segments.
2. Click the **Break Line**  edit button once or press the 3 key.
3. Click the edge to create a new corner edit handle at that location and two separate edges on either side of that handle.

If you click and drag one of the edit handles on either side of the partial break, the edge moves at a right angle to itself and another edge forms, connecting the moved edge with the one on the other side that does not move.

You can remove an edge from a polyline-based object by clicking and dragging a corner handle until it snaps to an adjacent corner handle.

When a complete break is created, the object or edge is totally severed at that point.

With the exception of framing members, complete breaks cannot be created on CAD-based architectural objects. In the case of framing members, only complete breaks can be created.

To create a complete break

1. Click the object or edge that you want to break into two segments.
2. Double-click the **Break Line**  edit button.
3. Click the edge to create a complete break at that location.

You can now click either side of the location of the break and move the selected object or edge completely independent of the object or edge on the other side of the break.

When **Object Snaps**  are enabled, breaks can be placed at snap locations such as midpoints. See “Object Snaps” on page 110.

If you place a complete break at a polyline corner, the adjacent polyline edges become disconnected.

Change Line/Arc

 Select an individual line-based or arc-based object or a segment of a polyline-based object and click the **Change Line/Arc** edit button to convert the selected segment from a line to an arc or vice versa.

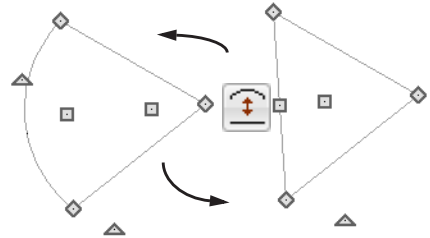
**Make Parallel/Perpendicular**

 The **Make Parallel** edit button can be used to reshape a polyline by making a selected edge parallel or perpendicular to another straight edge. See “Using Make Parallel/Perpendicular” on page 155.

Fillet Two Lines

 The **Fillet Two Lines** edit tool allows you to connect two non-parallel line-based objects using an arc of a specified radius. If the two lines are already connected, this arc is inserted between them.

If the two objects are not connected and one of them is an arc, both objects will extend or

contract as needed to become connected. No additional arc is created.

The **Fillet Two Lines**  edit tool is available for a selected roof or ceiling plane; however, it cannot be used to create an arc at a corner. Instead, it can only be used to remove edges.

To use Fillet Two Lines

1. Click on a line or polyline segment that you would like to connect to another line or segment with a filleted corner.
2. Double-click the **Fillet Two Lines**  edit button to open the **Fillet/Chamfer** dialog.

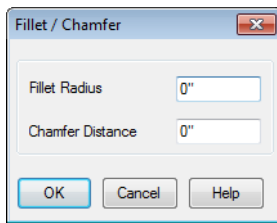

3. Specify the desired **Fillet Radius** and click OK.
4. Click on the line or polyline segment that you want the selected line to connect to with a fillet.
5. Continue filleting two lines by clicking on one line, clicking the **Fillet Two**

Lines  edit button, then clicking on the second line. The same Fillet Radius is used until you open the **Fillet/Chamfer** dialog again and change it.

Once two lines are filleted, the arc between them can be edited. See “Editing Arc Based Objects” on page 130.



The **Fillet Two Lines**  edit tool can also be used to join non-adjacent edges of an open or closed polyline as long as those edges are not parallel. In doing so, the edges will lengthen or shorten and polyline edges may be removed.

To remove polyline edges



1. Click on a polyline edge that you would like to connect to another edge.
2. Click the **Fillet Two Lines**  edit button.
3. Click on a non-adjacent edge of the same polyline. The edges will lengthen or shorten as necessary to join together.

Chamfer Two Lines

 The **Chamfer Two Lines** edit tool allows you to create a straight corner bevel of a specified size connecting any two non-parallel lines. It can also be used to extend an arc so that it joins to another arc.

The **Chamfer Two Lines**  edit tool is used much the way as the **Fillet Two Lines**  edit tool. First, set the Chamfer Distance in the **Fillet/Chamfer** dialog, then select a line, click the button and click a second line to chamfer the two.

Deleting Intervening Lines

Fillet Two Lines  and **Chamfer Two Lines**  can also be used to eliminate parts of a polyline. To use, fillet or chamfer two non-adjacent lines that are in the same closed polyline.

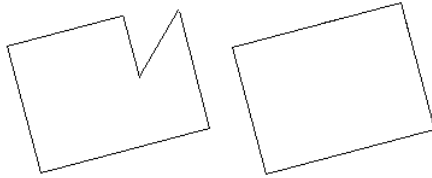

A dialog warns you that lines will be deleted if you proceed. Click **OK** to approve the polyline edit and see the changes occur.

Close Polyline



An open polyline-based object can be converted into a closed polyline using the **Close Polyline** edit tool. See “Using Close Polyline” on page 138.

Rotating Objects

Objects can be rotated using the edit handles as well as a variety of edit tools. Multiple selected objects can also be rotated as a group. See “Selecting Objects” on page 124.

By default, an object or group of objects rotate about the center point of the selection set. You can instead specify that objects rotate about the current CAD point. See “The Current Point” on page 774.

Using the Edit Handles

Select an object, then click the triangular **Rotate** edit handle and drag it in any direction. When your pointer is over the Rotate handle, it displays a curved arrow.

The angles of line-based objects can also be changed by dragging an end handle in a direction other than parallel to the object. The object rotates about the opposite end point. See “Editing Line Based Objects” on page 127.

When **Angle Snaps**  are enabled, objects snap to Allowed Angles as specified in the **Plan Defaults** dialog as they are rotated. See “Angle Snaps” on page 111.

To override any movement restrictions caused by snap settings or the presence of other objects, press the Ctrl key while dragging an edit handle.

You can temporarily slow the movement of your mouse as you drag an edit handle by holding down the Shift key on your keyboard.

Using the Specification Dialog





The exact angle of some objects such as lines, arcs, walls and the selected edges of polylines can be specified on either the General tab, Selected Line tab, or Selected Arc tab of that object’s specification dialog. See “Polyline Specification Dialog” on page 791.

Rotate/Resize About

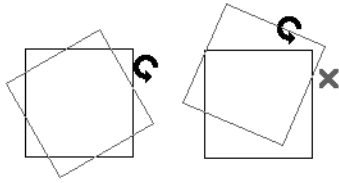

Objects can be rotated or resized about either their own centers or the current CAD point. See “The Current Point” on page 774.



You can specify which behavior is used by selecting **Edit > Edit Behaviors > Rotate/Resize About Current Point** . When this option is selected, objects rotate about the current CAD point; when it is not selected, objects rotate about their centers.

The Rotate/Resize About behavior can also be specified in the **Preferences** dialog. See “Behaviors Panel” on page 78.

Using Angular Dimensions

 **Angular Dimensions** are useful for adjusting the angles of a variety of objects with straight edges. See “Angular Dimensions” on page 729.

To change an angular dimension

1. Draw an **Angular Dimension**  between the objects you want to move.
 - Begin and end as close as possible to the two objects you wish to locate.
2. Select the edge that you want to move.
3. Click the dimension value to open the **Set Angular Dimension** dialog.
 - The **Previous Value** is indicated in degrees, minutes and seconds.

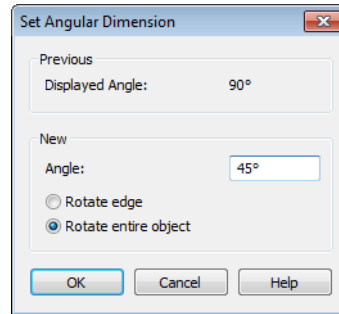

4. Enter a value in the **New Value** field.
5. Select **Rotate Edge** to move the selected edge when OK is clicked or select **Rotate entire polyline** to rotate the entire object the selected edge is a part of, maintaining the Previous Value of the angle.
6. Click **OK** to apply the change.

When an entire polyline is rotated using the **Set Angular Dimension** dialog, it rotates around the vertex of the angle.

Make Parallel/Perpendicular with Polyline Based Objects

 The **Make Parallel/Perpendicular** edit button usually adjusts the angle of a selected polyline edge. See “Using Make Parallel/Perpendicular” on page 155.

To rotate the entire polyline instead, double-click the **Make Parallel**  edit button to open the **Make Parallel** dialog.

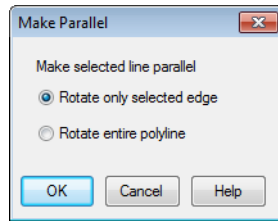

Choose to either **Rotate only selected edge**, as before, or to **Rotate entire polyline**. Your setting remains until you access the **Make Parallel** dialog again and change it.

Polylines rotate according to the current **Rotate/Resize About** setting. See “Behaviors Panel” on page 78.

Using the Transform/Replicate Object Dialog



Objects and groups of objects can be rotated to a relative or absolute angle using the **Transform Replicate Object** dialog. See “Transform/Replicate Object Dialog” on page 166.

Rotate Plan View



To rotate everything in floor plan view, including all objects on all floors, the Snap and Reference Grids, the plan’s Cartesian coordinates, and the

drawing sheet, select **Tools> Rotate Plan View** to open the **Rotate Plan View** dialog.

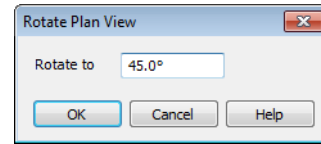

Enter the degrees to rotate the floor plan view to using decimal units with either positive or negative values.

The degrees rotated displays in $\pm 180^\circ$ format. For example, if you enter 270° , it displays as -90° when the dialog is reopened.

Rotate Plan View  rotates a plan relative to its original orientation. For example, entering 90° twice results in a rotation of 90° , not 180° .

Text objects rotate with the plan unless you uncheck **Rotate with plan** in the **Text Specification** dialog for each object. See “Rich Text Specification Dialog” on page 747.



The Rotate Plan View tool does not rotate objects; it literally rotates your view of those objects. As a result, it does not alter the orientation of the plan in layout views or on the printed page.

Reflecting Objects

There are several ways to reflect an object, group of objects, or an entire plan about an axis or another object. Either the original object(s) or copies of the original(s) can be reflected.

Reflect About Object



A selected object or objects can be reflected about another object, regardless of its angle, using the **Reflect About Object** edit tool.

Line-based objects are often used for reflecting a selection, but most objects have an axis that can be used.

- When an open or closed polyline-based object is used as the reflective object, the edge that is clicked on acts as the axis.
- When a circle or box-based object such as a CAD box or cabinet is used as the reflective object, the axis runs down the center of the object from back to front.
- In 3D views, architectural objects can only be reflected about a vertical axis - not a horizontal axis.

To use Reflect About Object

1. Draw a CAD line to act as the reflection line.
2. Select the object(s) to be reflected.
3. Click the **Reflect About Object**  edit button.
4. Click the CAD line to reflect the selection about the line.
5. The selection is reflected around the CAD line, and the original is no longer there.

To retain a copy of the selected object(s) in the original location, click the **Copy/**

Paste  edit button before clicking the

Reflect About Object  button.

Using the Transform/ Replicate Object Dialog



Objects and groups of objects can also be reflected horizontally or vertically using the **Transform Replicate Object** dialog. See “Transform/Replicate Object Dialog” on page 166.

Reverse Plan



The **Reverse Plan** tool is a quick way to mirror a plan so that everything on all floors of the entire plan is swapped left to right.

Select **Tools> Reverse Plan**  to reflect an entire plan right to left, as though it were reflected about a vertical line.

Reversing a plan rebuilds the entire model and affects views sent to layout.

Reverse Direction



Select a line-based, arc-based or polyline-based object and click the **Reverse Direction** edit button to reverse its direction. Not available for Terrain Path objects.

Reversing a line or polyline is useful with certain line styles or with an arrow at one end.

Converting Objects

CAD objects and many CAD-based objects can be converted into a variety of other types of objects.

CAD to Walls



CAD to Walls allows you to convert a 2D line drawing into a 3D model.

Double CAD lines and arcs drawn to represent wall layers and other structural items can be converted to actual Home Designer Pro walls, railings, windows, or doors. See “CAD to Walls” on page 208.

Convert Polyline



The **Convert Polyline** edit button lets you to turn CAD objects into CAD-

based architectural objects such as counter tops and stair landings, special polylines such as materials list polylines, and a variety of slab, hole and terrain objects.

To convert a CAD object into one of these 3D objects, select the object and click the

Convert Polyline  edit button to open the **Convert Polyline** dialog.

Convert Polyline Dialog

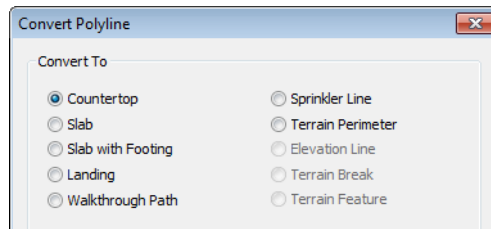

Click the radio button beside one of the objects in this dialog, then click OK.

Countertop - Convert the selected closed polyline to a countertop. See “Custom Countertops” on page 510.

Slab - Convert the selected closed polyline to a slab. See “The Slab Tools” on page 341.

Slab with Footing - Convert the selected closed polyline to a slab with footing.

Landing - Convert the selected closed polyline to a landing. Only available when the closed polyline is not a spline. See “Landings” on page 406.

Walkthrough Path - Convert the selected polyline to a Walkthrough Path. See “Walkthroughs” on page 819.

Sprinkler Line - Convert to a sprinkler line. See “Sprinkler Tools” on page 580.

Terrain Perimeter - Convert to the terrain perimeter. See “Terrain Perimeter” on page 538. This option is only available when:

- The polyline is closed
- A terrain perimeter does not yet exist
- Only one polyline is currently selected

Elevation Line - Convert to an elevation line. See “Elevation Lines” on page 542. Only available when a terrain perimeter exists.

Terrain Break - Convert to a terrain Break. See “Terrain Breaks” on page 544.

Terrain Feature - Convert to a terrain feature. See “Terrain Feature Tools” on page 546. Only available when a terrain perimeter exists.

Click **OK** to convert the object or objects.

The specification dialog appropriate to the newly converted object opens, allowing you to specify its height, material and other information.

Convert to Plain Polyline



Click the **Convert to Plain Polyline** edit button to convert special polylines to plain polylines.

After a special polyline is converted into a plain polyline, it can be converted into a special of the same or different type.

Transform/Replicate Object Dialog



Select any object or group of objects and click the **Transform/Replicate Object** edit button to open the **Transform/Replicate Object** dialog.

If multiple options are selected in the **Transform/Replicate Object** dialog, they are performed in the order they appear in the dialog, from top to bottom.



Always double-check values entered in the Transform/Replicate Object dialog. Large offset values, resize factors, or numbers of copies can result in objects that are time-consuming to create or may be off the screen.

Transform/Replicate Object Dialog

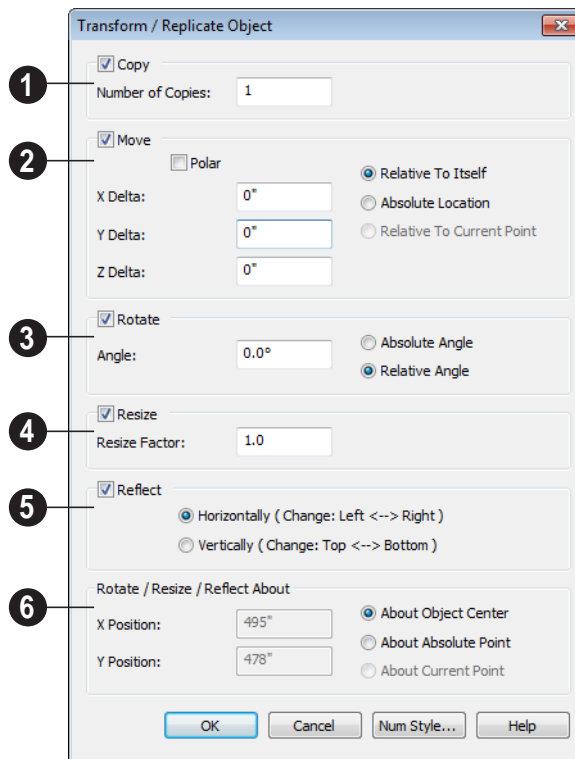

- 1** Check **Copies**, then specify the **Number of Copies** to make.
- 2** Check **Move**, then specify how far or where to move the object(s).
 - Select **Relative to Itself** to move the object relative to its current position, then specify the **X Delta**, **Y Delta** and **Z Delta** values, which are the object's changes in position along each axis.
 - Select **Absolute Location** to move the object to an absolute location. You can either specify its **X** and **Y Position**, or **Angle** and **Distance**, if **Polar** is checked.

- Select **Relative to Current Point** to move the object relative to the current CAD point. See "Point Tools" on page 772. You can either specify its **X Delta** and **Y Delta**, or **Angle** and **Distance**, if **Polar** is checked.



When a CAD-based object is moved to a new floor, only its display in floor plan view is moved - its physical locations in the model remains unchanged. See "Architectural vs CAD Objects" on page 108.

- 3** **Rotate** - Select this option, then specify the **Angle** to rotate the object(s).

- Select **Absolute Angle** to rotate the object relative to an imaginary horizontal line drawn in the positive X direction from the origin. See “3D Drafting” on page 25.
- Select **Relative Angle** to rotate the object the specified angle relative to its current orientation.

You can also specify the point the selected object(s) rotate about, below.

- 4 Select **Resize**, then specify the **Resize Factor** in decimals. A resize factor of 2 doubles the size of the object, while a resize factor of 0.5 halves the object’s size. Not available for all objects, including line- and arc-based objects and Primitives.

You can also specify the point the selected object(s) is resized about, below.

- 5 **Reflect** - Select this option, then specify which axis to reflect about.
 - **Horizontally** - Select this option to reflect the object horizontally.

- **Vertically** - Select this option to reflect the object vertically.

You can also specify the point the selected object(s) is reflected about, below.

- 6 **Rotate/Resize/Reflect About** - This section is enabled when the **Rotate**, **Resize** and/or **Reflect** functions are selected.

- **X Position** - Specify the X coordinate of the point to perform the selected edit function(s) about when **About Absolute Point** is selected.
- **Y Position** - Specify the Y coordinate of the point to perform the selected edit function(s) about when **About Absolute Point** is selected.
- **About Object Center** - Select this option to perform the selected edit function(s) about the object’s center.
- **About Absolute Point** - Select this option to perform the selected edit function(s) about the specified point.
- **About Current Point** - Select this option to perform the selected edit function(s) about the current CAD point.

Edit Area Tools



The **Edit Area Tools** allow you to quickly define an area of your plan and select the objects in that area. Once selected, they can then be repositioned, copied or deleted. Select **Edit > Edit Area** to access the **Edit Area Tools**.

Unlike other selection methods, the **Edit Area Tools**  cut walls, railing and fencing where the selection marquee intersects them,

allowing you to edit only the selected portion of these objects.

Some objects, such as cabinets, are included in the selection only if more than half of the object is contained within the marquee.

A few objects, notably CAD points, are not affected by the **Edit Area Tools** .



The Edit Area tools can cause widespread changes across an entire plan and should always be used with caution.

Edit Area



Select **Edit > Edit Area > Edit Area** and draw a rectangular marquee around the area of the plan to be edited.

Edit Area  affects all objects included in the selection marquee that are located on the current floor, regardless of whether they are displaying in floor plan view or not.

Edit Area Visible



Select **Edit > Edit Area > Edit Area Visible** and draw a marquee around the area of the plan to be edited.

Edit Area Visible  only affects visible objects included in the selection marquee; objects not currently displayed in floor plan view are unaffected.

Edit Area (All Floors)



Select **Edit > Edit Area > Edit Area (All Floors)** and draw a marquee around the area of the plan to be edited.

Edit Area (All Floors)  affects all objects on all floors of the plan that are included in the selection marquee, regardless of whether they display in floor plan view.

Edit Area (All Floors) Visible



Select **Edit > Edit Area > Edit Area (All Floors) Visible** and draw a

marquee around the area of the plan to be edited.

Edit Area (All Floors) Visible  affects all visible objects on all floors of the plan that are included in the selection marquee. Objects not currently displaying in floor plan view are not affected.

Edit Area Polyline

If a rectangular marquee's shape does not allow you to define an area precisely, use a closed polyline instead.

Select a polyline that defines the desired area in floor plan view and then select one of the

Edit Area Tools . The polyline becomes temporarily highlighted and acts as an Edit Area marquee.

Using the Edit Handles

An Edit Area marquee displays edit handles that are similar to those of a closed polyline. See “Using the Edit Handles” on page 139.







- Click the **Move** edit handle to move the entire selection set. See “Moving Objects” on page 152.
- Click the **Rotate** edit handle to rotate the entire selection set. See “Rotating Objects” on page 161.
- Click and drag the **Reshape** and **Resize** edit handles at each corner and along each edge to adjust the size and shape of the marquee. See “Using the Edit Handles” on page 139.



Adjusting the size or shape of an Edit Area marquee may change which objects are included in the selection set but does not otherwise affect those objects.

Using the Edit Toolbar

A selected Edit Area marquee and/or the objects within it can be edited in a variety of ways using the buttons on the edit toolbar. See “Using the Edit Toolbar” on page 140.

The following toolbar buttons may display on the edit toolbar for an Edit Area marquee:

- Click the **Copy/Paste**  edit button to copy the selection set to the Windows Clipboard so it can be pasted elsewhere. See “Copying and Pasting Objects” on page 114.
- Click the **Delete**  edit button to delete the selection set. See “Deleting Objects” on page 171.
- Click the **Transform/Replicate Object**  edit button to copy, move, rotate, resize, or reflect the selection set. See “Transform/Replicate Object Dialog” on page 166.
- Click the **Accurate Move**  edit button to slow down the mouse speed when using the edit handles. See “Accurate Move” on page 153.
- Click the **Make Parallel/Perpendicular**  edit button to rotate the Edit Area marquee and the selection set so that the selected marquee edge is parallel or perpendicular to another straight edge. See “Using Make Parallel/Perpendicular” on page 155.
- Click the **Point to Point Move**  edit button to accurately move the selection set. See “Point to Point Move” on page 153.

- Click the **Center Object**  edit button to center the selection along along a wall within a room or relative to a cabinet fixture. See “Using Center Object” on page 156.
- Click the **Reflect About Object**  edit button to reflect the selection set about another object. See “Reflecting Objects” on page 163.
- Click the **Allowed Angles**  edit button to open the **Place at Allowed Angles** dialog.

Place at Allowed Angles Dialog

 If more than one percent of the straight walls included in an Edit Area marquee are not at an allowed angle, the **Allowed Angles** edit button displays.

Click the **Allowed Angles**  edit button to display the **Place at Allowed Angles** dialog.

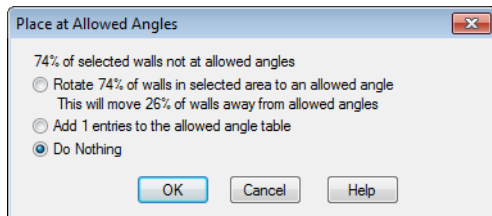

Select the first option and click **OK** to rotate the plan so that the largest group of off-angle walls move to an Allowed Angle. This may place this largest group at Allowed Angles, but has two disadvantages.

- First, other groups of off angle walls remain off angle.

- Second, any walls that were at an allowed angle before this action will move to an off angle. The dialog shows how much (weighted by length) of the selected walls are in each category.

Select the second option and click **OK** to add new entries to the Allowed Angles list and allow new walls to be placed at these angles. Walls already at Allowed Angles remain so. See “Angle Snaps” on page 111.



Select the third option and click **OK** to do nothing, which is the same as clicking **Cancel**.

You may want to rotate the majority of the walls to one of the normal allowed angles.

Then, use an **Edit Area**  tool to select everything again and select the second option to provide new angle entries to cover the remaining walls.

Deleting Objects

Objects can be deleted in a variety of ways:

- Select an object or group of objects, then click the **Delete**  edit button, select **Edit> Delete**  from the menu, or press the either the Delete or Backspace key on your keyboard.
- Entire categories of objects can be deleted using the **Delete Objects** dialog.
- Objects are deleted if the floor they are placed on is deleted. See “Deleting Floors” on page 320.

If an object has a line with arrow or text leader attached to it, the arrow or leader is deleted if the object is deleted. To prevent the arrow from being deleted, drag the attached end away from the object before deleting it.

A variety of objects in the program can be generated automatically, including roofs, the

foundation, and framing. Automatically generated objects cannot be deleted unless the automatic creation option is disabled.

Delete Objects Dialog



Use the **Delete Objects** dialog to delete all objects of one or more specified types in one room, on the current floor, or in the entire plan.



Although objects on locked layers cannot be selected, most can nevertheless be deleted using the Delete Objects dialog.

To use the Delete Objects dialog

1. Select **Edit> Delete Objects**  to open the **Delete Objects** dialog.

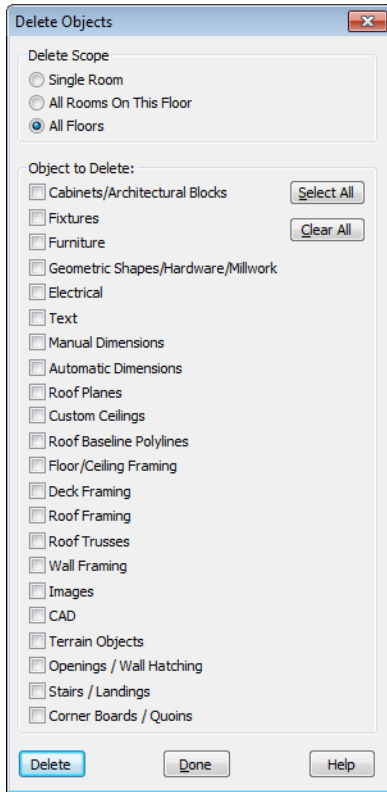



2. Specify the **Delete Scope** as **Single Room**, **All Rooms On This Floor**, or **All Floors**.
3. In the **Delete** section, check the box for each category of objects you want to delete. Click **Select All** to check all the boxes or **Clear All** to uncheck all boxes.
 - If “Roof Planes” cannot be selected, they may be locked. See “Editing Roof and Ceiling Planes” on page 365.
4. When the scope is set to **Single Room**:
 - Move your cursor into the drawing area and click in a room of the plan to delete

objects of the selected type within that room without closing the dialog.

- Continue clicking on rooms or choose a different Delete Scope.
 - Click **Done** when all selections have been deleted.
5. If you select **All Rooms On This Floor** or **All Floors**, you do not need to click in floor plan view. The **Delete** button becomes available, and clicking it closes the dialog and deletes the specified objects.

Deleting Polyline Edges

There are number of different ways to delete individual edges of polyline-based objects:

- Select **Edit Object Parts** . Select the edge and delete. See “Edit Object Parts” on page 125.
- Drag a corner handle until it overlaps an adjacent corner handle to remove the edge between them and merge them into a single handle.
- Create a complete break at both ends. Select the edge and delete. See “To create a complete break” on page 159.
- The **Fillet Two Lines**  and **Chamfer Two Lines**  tools can be used to delete polyline edges. See “Reshaping Objects” on page 158.

Delete Surface

 In any 3D view, select **3D> Delete Surface**, then click a surface in the view to temporarily remove the surface from the current view without permanently



affecting the object. See “Delete 3D Surface” on page 679.

Undo and Redo



The **Undo** and **Redo** commands allow you to both undo the last action performed, as well as redo actions that were recently Undone.

The ten most recent actions can be Undone or Redone, depending on your settings in the **Preferences** dialog. See “General Panel” on page 67. Actions that can be Undone and Redone include creating, editing, and deleting objects.

To Undo an action, select **Edit> Undo** , click the **Undo**  button, or press Ctrl + Z on your keyboard.

The Redo command is only available immediately after Undo has been used. To Redo an Undone action, select **Edit>**

Redo , click the **Redo**  button or press Ctrl + Y on your keyboard.

It is important to note that **Undo**  and

Redo  do not affect all actions in the program, including:

- Save and Save As. See “Saving, Exporting, and Backing Up Files” on page 43.
- Changes made in the Library Browser. See “The Library Browser” on page 604.
- Changes made in a dialog while the dialog box is open. See “Dialogs” on page 30.
- Changes made to the display by panning the display or zooming in or out. See “Undo Zoom” on page 654.

Walls, Railings & Fencing

Walls are the single most important building component in Home Designer Pro. By creating walls and defining the rooms created by the walls, you are telling the program how you want the 3D model built.

There are several ways that walls can be created in Home Designer Pro. The most common is to simply draw them with the Wall Tools.

In addition, exterior walls can be generated automatically when a new floor is built by using another floor as a model. For more, see “Adding Floors” on page 317.

2D CAD lines can also be converted into actual walls using the **CAD to Walls** tool.

Another feature that can be used to generate walls automatically is the **House Wizard**. See “House Wizard” on page 799.

Chapter Contents

- Wall, Railing, and Fencing Defaults
- The Wall Tools
- The Deck Tools
- The Fencing Tools
- Exterior and Interior Walls
- Foundation Walls
- Pony Walls
- Railings
- Invisible Walls
- Polygon Shaped Decks
- Hatch Wall
- Break Wall
- Drawing Walls
- Connecting Walls
- Displaying Walls
- Measuring Walls
- Editing Walls
- Editing Straight/Curved Wall Combinations
- Aligning Walls
- Roof Directives in Walls
- Attic Walls
- Stepped and Raked Walls

- CAD to Walls
- Wall Type Definitions
- Wall Type Definitions Dialog
- Wall Specification Dialog
- Railing and Fencing Specification Dialogs
- Wall Hatch Specification Dialog

Wall, Railing, and Fencing Defaults



There are several defaults dialogs for walls. Default Settings can be accessed by selecting **Edit> Default Settings**. Click the + next to “Walls” to display the walls sub-headings. Select a subheading and click the **Edit** button to open the **Wall Defaults** dialog associated with your selection:

The defaults dialog for each wall tool can also be accessed by double-clicking its toolbar button.

The settings in the various wall defaults dialogs determine what wall types are drawn when the different wall tools are used. It is a good idea to be familiar with these settings and how they relate to your style of building. See “Wall Type Definitions” on page 209.

General Wall Defaults



The **General Wall Defaults** dialog controls the general behavior and display attributes of all walls, railings and fencing.

For quick access, the **General Wall**

Defaults  button can be added to the toolbar or you can press Alt+Q on your keyboard.

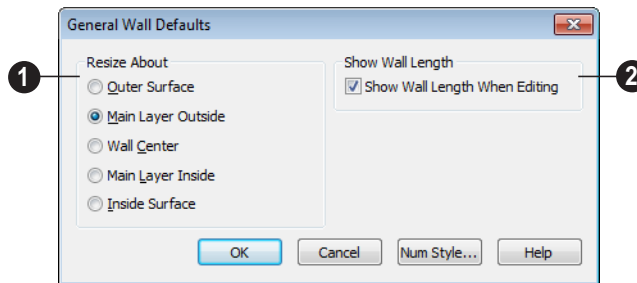

1 **Resize About** - These radio buttons determine what part of a wall retains its position when its wall type or wall type definition is changed. See “Resize About” on page 202.

The **Resize About** location is also where any snap points will be located along a wall as it

is drawn or connected to other walls, and is where a wall’s length is measured.



- **Outer Surface** - Snap to and resize about the exterior surface. When a wall is resized, its exterior surface does not move.

- **Main Layer Outside** - Snap to and resize about the outer line of the Main Layer. When a wall is resized, the outer line of its Main Layer does not move.
- **Wall Center** - Snap to and resize about the center line. When a wall is resized, its center line does not move, but wall layers on either side may.
- **Main Layer Inside** - Snap to and resize about the inner line of the Main Layer. When a wall is resized, the inner line of its Main Layer does not move.
- **Inside Surface** - Snap to and resize about the interior surface. When a wall is resized, its interior surface does not move.

Note: In most circumstances, it is recommended that you Resize About the Main Layer Outside to avoid unexpected results.

- 2 Check **Show Wall Length When Editing** to display a temporary length dimension when a wall is drawn or edited. Wall length only displays when **Display Temporary Dimensions**  is on. See “Display Temporary Dimensions” on page 731.

Exterior/Interior Wall Defaults Dialog

Specify which wall types are drawn using the **Exterior Wall**  and **Interior Wall**  tools in the **Exterior/Interior Wall Defaults** dialog.

You can also double-click the **Straight** or **Curved Exterior** or **Interior Wall** toolbar buttons to open this dialog.

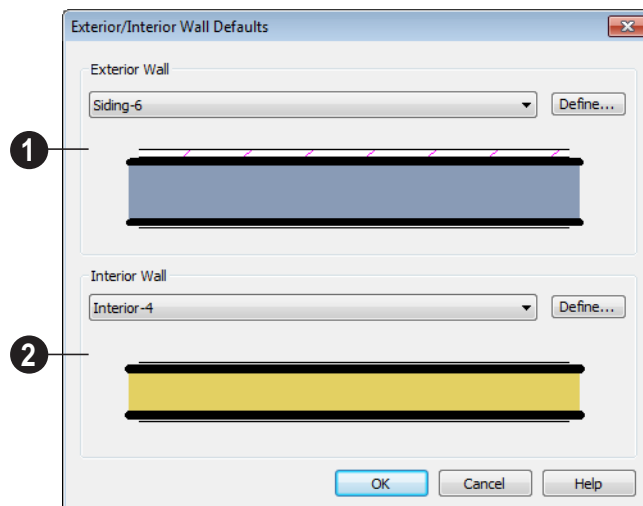

- 1 **Exterior Wall Tool** - From the drop-down list, select the wall type drawn

with the **Exterior Wall**  tool.



Click the **Define** button to open the **Wall Type Definitions** dialog. See “Wall Type Definitions Dialog” on page 211.

2 Interior Wall Tool - From the drop-down list, select the wall type drawn by the **Interior Wall**  tool.

Click the **Define** button to open the **Wall Type Definitions** dialog.

Foundation Wall Defaults

Specify which wall types is drawn when the **Foundation Wall**  tool is used either manually or when a stem wall or pier foundation is generated in the **Foundation Wall Defaults** dialog. See “Foundation Walls” on page 183.

The **Foundation Wall Defaults** dialog also controls the wall type drawn by the **Retaining Wall**  tool. Unlike other walls, **Retaining Walls**  are used to modify your

terrain rather than build a structure. See “Terrain Wall and Curb Tools” on page 549.

Footing size and other information used when building stem wall or pier foundations is also specified here. For more information, see “Foundation Defaults” on page 330.

The tabs in this dialog are the same as their respective tabs in the **Wall Specification** dialog. See “Wall Specification Dialog” on page 214.

Pony Wall Defaults

Specify the wall types used for the upper and lower portions of pony walls and other data associated with pony walls in the **Pony Wall**

Defaults dialog. See “Pony Walls” on page 184.

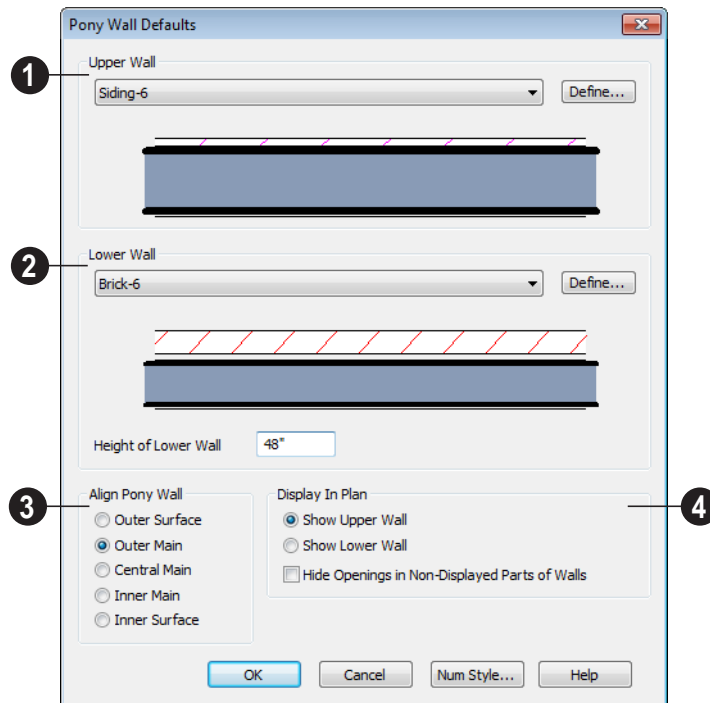

- 1 Upper Wall** - From the drop-down list, select the default wall type for the upper portion of pony walls.

 - Click the **Define** button to open the **Wall Type Definitions** dialog, where you can create and modify wall types. See “Wall Type Definitions Dialog” on page 211.
- 2 Lower Wall** - From the drop-down list, select the default wall type for the lower portion of pony walls.

 - **Height of Lower Wall** - Specify the default height of the lower portion of pony walls.
 - Click the **Define** button to open the **Wall Type Definitions** dialog.
- 3 Align Pony Wall** - Specify the default option for aligning the layers of the upper and lower pony walls. See “Wall Types Tab” on page 221.

 - Select **Outer Surface**
 - **Outer Main** (selected)
 - **Central Main**
 - **Inner Main**
 - **Inner Surface**
- 4 Display In Plan** - Specify how pony walls appear in floor plan view.

 - Select **Show Upper Wall** to display this wall type in floor plan view instead of the lower wall type.
 - Select **Show Lower Wall** to display this wall type in floor plan view instead of the upper wall type.
 - Check **Hide Openings in Non-Displayed Parts of Walls** to hide any doors and windows located in the parts of pony walls that are not visible. When unchecked,

these openings will display along with those located in the visible parts of pony walls.



Railing and Deck Railing Defaults

Specify the types of railings created when the Railing and Deck Railing tools are used. See “Railings” on page 185.

The tabs in these dialogs are the same as their respective tabs in the **Wall Specification** dialog. See “Wall Specification Dialog” on page 214.

Note: By default, Railings and Deck Railings are drawn using two separate wall types: “Interior Railing” and “Deck Railing/Fence”. See “Wall Type Definitions” on page 209.

Half-Wall Defaults

Double-click the **Half-Wall**  or **Curved Half-Wall**  button to open the **Half-Wall Defaults** dialog and specify the attributes of a solid railing drawn using either Half Wall tool.

The tabs in this dialog are the same as their respective tabs in the **Wall Specification** dialog. See “Wall Specification Dialog” on page 214.

Fencing Defaults

Double-click the **Fencing Tools**  parent button or either of its child tools to open the **Fencing Defaults** dialog and specify the attributes of fencing drawn using either **Fencing** tool.

The tabs in this dialog are the same as their respective tabs in the **Wall Specification** dialog. See “Wall Specification Dialog” on page 214.

Invisible Wall Defaults

Double-click the **Invisible Wall**  button to open the **Invisible Wall Defaults** dialog and specify what type of wall is drawn when using the Invisible Wall tool. See “Invisible Walls” on page 187.

The tabs in this dialog are the same as their respective tabs in the **Wall Specification** dialog. See “Wall Specification Dialog” on page 214.

The Wall Tools



Select **Build> Wall** to access the Wall Tools. The type of wall drawn by each wall tool is specified in its corresponding defaults dialog.



The **Curved Wall** tools are similar to their corresponding **Straight Wall Tools**. Select **Build> Curved Wall** to access these tools.

Exterior Walls



The **Exterior Wall** and **Curved Exterior Wall** tools draw walls using the default wall type specified for exterior walls in the **Exterior/Interior Wall Defaults** dialog. See “Exterior and Interior Walls” on page 183.

Interior Walls



The **Interior Wall** and **Curved Interior Wall** tools draw walls using the wall type specified for interior walls. The interior wall type is defined in the **Exterior/Interior Wall Defaults Defaults** dialog.

Note: Whether a wall is recognized as an exterior or interior wall by the program is determined by its position in the model, not by the tool used to draw it. See “Exterior and Interior Walls” on page 183.

Foundation Walls



The **Foundation Wall** and **Curved Foundation Wall** tools draw foundation walls. Foundation walls normally have a footing and can be drawn on any floor of the model, not just the

foundation floor. See “Foundation Walls” on page 183.

Pony Walls



A **Pony Wall**, also called a split wall, is defined as a wall with two separate wall types, one for the upper portion and another for the lower portion.

The **Pony Wall** and **Curved Pony Wall** tools draw pony walls using the information specified in the **Pony Wall Defaults** dialog. You can also convert a normal wall into a pony wall and vice versa in the **Wall Specification** dialog. See “Pony Walls” on page 184.

Railings



The **Railing** and **Curved Railing** tools create railings. The style and height of railings drawn with this tool are defined in **Railing Defaults** dialog. See “Railing and Deck Railing Defaults” on page 180.

Half-Walls



The **Half-Wall** and **Curved Half-Wall** tools create solid railings: walls that are 36” (900 mm) high topped with a handrail. The height and other attributes of solid railings drawn with this tool are defined in **Half-Wall Defaults** dialog. See “Half-Wall Defaults” on page 180.

Invisible Wall



Invisible Walls are walls used to define separate room areas in a plan.

They can display in floor plan view but not in 3D views. You can also convert a normal wall into an invisible wall and vice versa in the **Wall Specification** dialog. See “Invisible Walls” on page 187.

Hatch Wall



The **Hatch Wall** tool applies a hatch pattern to a wall that displays in floor plan views. You must click the wall that you want to apply the hatch pattern to. You can then select the hatch and resize it if you want to only hatch a portion of a wall. See “Hatch Wall” on page 188.

Break Wall



The **Break Wall** tool applies a break in a wall. Once a wall is broken, the

two wall segments are separate walls that can be modified independent of each other. See “Break Wall” on page 189.

Fix Wall Connections



The **Fix Wall Connections** tool connects walls whose ends are within a few inches of each other but are not connected. See “Fix Connections” on page 192.

Define Wall Types



The **Define Wall Types** tool opens the **Wall Type Definitions** dialog, where wall types can be created, copied and edited. See “Wall Type Definitions Dialog” on page 211.

The Deck Tools



Select **Build> Deck** to access the Deck Tools. When a room is defined using deck railing, its **Room Type** is automatically set to “Deck”. See “Decks” on page 238.



Deck Railing



The **Straight Deck Railing** and **Curved Deck Railing** tools draw decks, complete with framing and bounded by a railing. If a foundation level exists, supports for the deck are also created. See “Railings” on page 185.

Deck Edges



The **Straight Deck Edge** and **Curved Deck Edge** draw decks complete with framing, but without a railing. No deck supports are created.

Polygon Shaped Deck



The **Polygon Shaped Deck** tool opens the **New Polygon Shaped Deck**

dialog, where you can specify the exact size and number of sides of a new polygonal deck room and then click in floor plan view to

create that deck room. See “Polygon Shaped Decks” on page 187.

The Fencing Tools



Select **Build> Fencing** or click the **Fencing Tools** to access the fencing tools.



The **Fencing** and **Curved Fencing** tools are used to draw fences, which are similar to railings but by default do not define room areas. Fencing is created and edited much like walls and railings, and normally used outside of a building and follows the shape of the terrain. See “Terrain” on page 537.

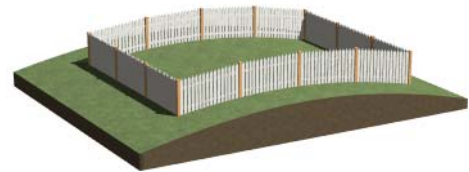

Fencing automatically follows the shape of the terrain. You can choose to have the

fencing follow the terrain smoothly or to have each segment step as it follows the terrain. See “Rail Style Tab” on page 224.



Define the default fence style in the **Fencing Defaults** dialog. See “Fencing Defaults” on page 180.

Exterior and Interior Walls

Most walls are drawn using either the **Exterior Wall**  or **Interior Wall**  tool. The only difference between these two tools is the wall type used. You can specify the default wall type for each tool in the **Wall Defaults** dialog.

To draw a wall using a different wall type, you can change the default wall type for either tool in the **Wall Defaults** dialog. You can also draw a wall using the default type

and then change the wall type in the **Wall Specification** dialog.

Whether a wall is recognized by the program as an actual exterior or interior wall is based on the model, not by which tool you use to draw the wall. Any wall that is entirely surrounded by interior room areas is considered an interior wall. Any wall exposed to the outside of the building is considered an exterior wall.

Foundation Walls



Foundation walls are similar to the interior and exterior walls but also

have a footing. Foundation walls can either be created automatically when a foundation

floor is created or manually by drawing them using the **Straight** or **Curved Foundation Wall** tool. See “Building a Foundation” on page 334.



The initial foundation wall type and footing size are specified in the **Foundation Wall Defaults** dialog. These values can be changed for individual walls in the **Wall Specification** dialog. See “Wall Specification Dialog” on page 214.

You can draw a foundation wall on any floor of a plan, not just on the foundation level. Any wall can be specified as a foundation

wall, regardless of the tool used to draw it. See “Foundation Tab” on page 219.

Foundation walls are placed on the “Walls, Foundation” layer. In floor plan view, foundation wall footings are placed on the “Footings” layer; in 3D views, they are on the “Walls, Foundation” layer. See “Displaying Walls” on page 192.

Slab Footings

When a monolithic slab foundation is created, the slabs are defined by specially defined foundation walls that have footing widths equal to that of the wall type - by default, 16” (350 mm). For Garage curbs, the footings should be wider than the wall type. See “Foundation Tab” on page 219.

Rooms defined by these Slab Footing walls will have a Ceiling Height of 0 and a Monolithic Slab Foundation. See “Structure Tab” on page 245.

Pony Walls



A **Pony Wall**, sometimes called a split wall, is a wall with two separate wall types for the upper and lower portions.

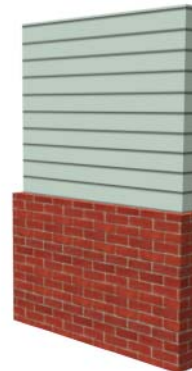

Walls drawn using the **Pony Wall**  tool are created using the wall types and other information specified in the **Pony Wall Defaults** dialog. See “Pony Wall Defaults” on page 178.

You can also convert a normal wall into a pony wall and vice versa in the **Wall Specification** dialog. See “Wall Types Tab” on page 221.

The height where the upper portion meets the lower can be adjusted in the **Wall Specification** dialog and in 3D views using the wall’s edit handles. Because the upper and lower sections of a pony wall are linked, if either portion is modified along the division between the two, such as raking or the stepping of a footing, the other portion of the pony wall adjusts to match. See “Stepped and Raked Walls” on page 207.

You can specify whether the upper or lower portion of pony walls displays in floor plan view in the **Pony Wall Defaults** dialog. This option can also be set for individual walls in the **Wall Specification** dialog.

Changing Wall Types for Pony Walls

The default upper and lower parts of a pony wall can be specified in the **Pony Wall Defaults** dialog. See “Pony Wall Defaults” on page 178.

The upper and lower parts of a pony wall can be redefined as different wall types in the **Wall Specification** dialog. See “Wall Types Tab” on page 221.

Note: The only way to control the materials displaying on a pony wall is by changing the wall types.

Railings

 Railings are created and edited just like walls. See “Drawing Walls” on page 189. The attributes for railings when they are first drawn are defined in the **Railing Defaults** dialog. See “Railing and Deck Railing Defaults” on page 180.

Railings are ideal for a number of tasks:

- Creating changes in floor and/or ceiling height. See “Floor & Ceiling Heights” on page 239.
- Creating stairwells. See “Creating a Stairwell” on page 419.
- Drawing decks. See “Decks” on page 238.



To produce a break in a railing for a stairway or other access, use a **Doorway** . This keeps the railing continuous and maintains

room definition. See “Room Definition” on page 231.

When first drawn, railings are specified as **No Locate**, which prevents **Auto Exterior Dimensions**  from locating them. The **No Room Def** attribute may also be helpful if you do not want a railing to divide an area into two separate rooms. See “General Tab” on page 214.

By default, newels and balusters do not display in floor plan view, but their display can be turned on. See “Newels/Balusters Tab” on page 226.

Railing Types

A variety of railing types can be specified in the **Railing** and **Deck Railing Specification** dialogs. See “Rail Style Tab” on page 224. Available types include:

- **Baluster** creates railings composed of newel posts, balusters, a railing, and an optional bottom rail.
- **Solid** produces a framed railing wall, or Half Wall. See “Half-Walls” on page 181.
- If **Panels** is selected, you can choose a panel style such as cable, glass, or iron-work from the library. See “Newels/Balusters Tab” on page 226.

Wall Types and Railings

Just like regular walls, railings are assigned a wall type: “Interior Railing”. This wall type has three layers: a framing layer in the

middle and a layer of drywall on each side. See “Wall Type Definitions” on page 209.

You can use a different wall type definition for railings if you wish, but bear in mind that this wall type definition determines several important things:

- The railing’s appearance in floor plan view. See “Displaying Walls” on page 192.
- The actual thickness of Solid railings in 3D views.
- The extent of the floor platform, if a platform edge is defined by the railing. is defined by the outer surface of the wall type. See “Floor and Ceiling Platforms” on page 321.
- If the railing is used to create a change in floor height, this wall type controls the structure and position of the partial wall built beneath the railing, if one is required. See “Floor & Ceiling Heights” on page 239.

If the railing is a type other than Solid, its sizing is specified on the Newels/Balusters tab of the **Railing Specification** dialog, and the railing is centered along the width of the wall type. This will not be evident in floor plan view unless newels and balusters are set to display.

Deck Railing is also assigned a wall type: “Deck Railing/Fencing”. This wall type has a single framing layer and is recommended for use only with deck railing and fencing.

Invisible Walls



Invisible walls can display in floor plan view but not in 3D views or the Materials List. They are used to create or modify room definition, most often by defining smaller areas within larger rooms. See “Room Definition” on page 231.

Invisible walls can also be used to define areas with different floor or ceiling materials or heights.

Common uses for invisible walls include dividing areas of an open floor plan into areas with different purposes.

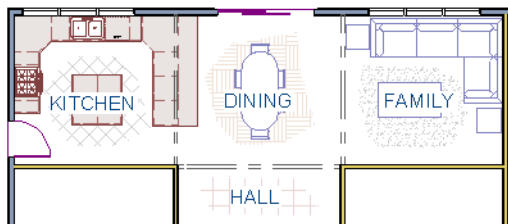

Invisible walls separate this dining area from adjacent rooms

An invisible wall can be turned into a normal wall, or vice versa, by clicking the **Invisible** check box in its **Wall Specification** dialog. See “General Tab” on page 214.

Invisible walls are drawn using the attributes specified in the Invisible Wall Defaults dialog and are placed on the “Walls, Invisible” layer by default. A wall placed on a non-default layer and then specified as Invisible, however, will not move to the “Walls, Invisible” layer. See “Invisible Wall Defaults” on page 180.

Important Notes on Invisible Walls

- Floor, wall and ceiling areas are calculated separately for rooms divided by invisible and normal walls.
- Invisible walls are ignored by the **Auto Place Outlets**  tool; it functions as though they were not present.
- Cabinets, fixtures and furniture can be moved freely through Invisible walls.
- Invisible walls can be drawn through a cabinet to attach to the wall behind.
- Invisible Walls are automatically generated to connect “island” rooms to the larger structure around them. See “Room Definition” on page 231.

Polygon Shaped Decks



Select **Build > Deck > Polygon Shaped Deck** to open the **New**

Polygon Shaped Deck dialog and create a polygon shaped deck with regular sides.

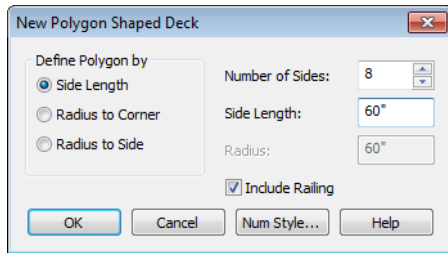

The settings in this dialog are saved between program sessions.

To create a polygon shaped deck

1. Click the radio button beside an option to specify whether you want to **Define**

Polygon by Side Length, Radius to Corner or Radius to Side.

2. Specify the desired **Number of Sides**.
3. Specify the desired **Side Length** or,
4. Specify the desired **Radius**.
5. Uncheck **Include Railing** to produce a deck platform defined by Deck Edges. This option is not available in the **New Polygon Shaped Room** dialog.
6. Click **OK**, then click once in floor plan view to create the specified polygon shaped deck.

Hatch Wall



The **Hatch Wall** tool can be used to fill wall segments with a single hatch pattern in floor plan view.

To apply wall hatching, select **Build > Wall > Hatch Wall** , then click on a wall. The hatch pattern covers the entire length and width of the wall segment.

Note: The Hatch Wall tool cannot be used to apply a hatch pattern to Invisible Walls. See “Invisible Walls” on page 187.

Hatch Wall  places a hatch pattern across all layers of the selected wall, covering any fill styles specified for that wall type.

In many cases, it is preferable to create a wall type definition rather than use the **Hatch**

Wall  tool because multiple fill styles can

be created for display purposes. See “Wall Type Definitions Dialog” on page 211.

Once created, wall hatching can be selected, edited and deleted much like other line-based objects. See “Editing Line Based Objects” on page 127.

If you use the **Hatch Wall**  tool to apply a hatch pattern to a wall that has been divided into multiple segments using the **Break**

Wall  tool, the pattern is only applied to the segment that you clicked on. See “Break Wall” on page 189.

Like doors and windows, wall hatching cannot extend across multiple wall segments. Unlike these objects, hatching cannot be located by dimension lines.

The wall hatch pattern and its line weight can be specified in the **Wall Hatch Specification**

dialog. See “Wall Hatch Specification Dialog” on page 227.

When editing or deleting wall hatching, make sure that it is selected rather than the

wall by noting that “Wall Hatching” displays in the Status Bar. See “The Status Bar” on page 31.

Break Wall



To divide a wall or railing, select **Build> Wall> Break Wall** and click on the wall. The wall is divided into two wall sections at the point where you click.

The **Break Wall**  tool remains active, so you can continue to place breaks in walls. When you are finished, select a different tool.

If a wall break is placed near the intersection of two walls, the break is positioned at the center of the intersection.

Once a break is placed, click the **Select**

Objects  tool and select the original wall. If edit handles display near the break, the wall was correctly broken.

Walls separated by a break can be rejoined. Select one of the segments, then click on the end edit handle located at the break and drag it a few plan inches (mm) away from the break. See “Connecting Walls” on page 191.

The **Break Wall**  tool can be used to create aligned walls on either side of a gap. See “Creating a Nook” on page 202.

Drawing Walls

Walls are drawn similar to the way CAD lines are drawn and can be drawn in floor plan view, camera views, and overviews. See “Draw Line” on page 776.

Drawing walls to create a floor plan is simple if you keep a few things in mind:

- Draw exterior walls first to define the building’s footprint, then draw the interior walls after the perimeter is in place.
- It is easiest to draw walls at the approximate location and length needed and then move or resize them precisely using dimensions later. See “Moving Objects Using Dimensions” on page 737.
- If you wish to input wall lengths as you draw, make sure your General Wall Defaults are set to **Resize About Outer Surface**. See “Entering Wall Lengths and Angles” on page 190.
- As walls are drawn, “sticky” points and extension lines identify points that are either collinear or orthogonal to the end points of other walls, making alignment easier. See “Extension Snaps” on page 111.
- When walls enclose an area to form a room, the program will orient all exterior walls so that the siding material faces out-

ward. See “Wall Type Definitions” on page 209.

- To flip the layers of a wall after it is drawn, select it and click the **Reverse Layers**  edit button. See “Editing Walls” on page 197.
- Initial wall heights are determined by the default floor and ceiling heights of the current floor. See “Floor Defaults Dialog” on page 316.

Wall Positioning

The recommended method of drawing walls is to draw them at their approximate location and length, then move them into position with accuracy using dimensions. To make this task quick and efficient:

- Notice the temporary wall that displays as you draw. Its length and angle display in the Status Bar at the bottom of the window and adjust as you move the mouse. Release the mouse button to draw the wall at the displayed length and angle. See “The Status Bar” on page 31.
- Use Snaps to help ensure proper wall alignment and orientation. See “Snap Behaviors” on page 109.

Once walls are drawn, they can be accurately dimensioned and moved as needed. See “Measuring Walls” on page 195.

Entering Wall Lengths and Angles

The fastest way to draw walls is to draw them at their approximate position and length, and then move or resize them accurately using dimensions. See “Using Dimensions” on page 198.

For those that wish to enter walls’ lengths and angles as they are drawn, first select **Resize About Outer Surface** in the **General Wall Defaults** dialog. See “Resize About” on page 202.

Then draw a wall, select it, and specify its **Length** and **Angle** in the **Wall Specification** dialog. Draw a second wall and specify its length and angle, and so on. See “General Tab” on page 214.

Wall Openings

To create a door or doorway, do not draw wall sections with a gap between them. Walls should be drawn to completely enclose rooms, and then door and window objects should be placed in the walls to create openings later. See “Doors” on page 253 and “Windows” on page 279.

Masonry fireplaces placed in walls are also considered to be types of wall openings. See “Fireplaces” on page 343.

Temporary Dimensions

Temporary dimensions will display along the length of a wall as it is drawn when **Display**

Temporary Dimensions  is toggled on and **Show Wall Length When Editing** is checked in the **General Wall Defaults** dialog. See “Display Temporary Dimensions” on page 731 and “General Wall Defaults” on page 176.

Drawing Curved Walls

Drawing a curved wall, curved railing, or curved fence is similar to drawing a CAD arc. See “Arc Tools” on page 785.

As with CAD arcs, the method used to draw a curved wall depends on which **Arc**

Creation Mode  is currently active. See “Drawing Arcs - Arc Creation Modes” on page 784.

A straight wall can also be converted into a curved wall and vice versa using the **Change**

Line/Arc  edit button. See “Change Line/Arc” on page 159.



To create a room in the shape of a circle, you must draw two curved walls.

A curved wall always has a center point. The center displays as a small cross when **Show**

Arc Centers and Ends  is enabled. See “Show Arc Centers” on page 134.

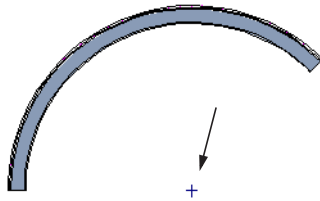

Show Arc Center

The radius of a curved wall is measured from the center to a surface or layer of the wall.

The radius can be defined in the **Wall Specification** dialog. You may elect to define the radius to the exterior or interior wall layers. See “General Tab” on page 214.

House Wizard



The House Wizard allows you to place and arrange room “objects” that can then be converted into a fully editable house plan, including walls. See “House Wizard” on page 799.

Wall Framing

Once walls have been drawn, they can be framed. For best results, avoid generating framing until your model is in its final form. See “Wall Framing” on page 436.

Connecting Walls

When walls are drawn sufficiently close to one another, they will snap together to form an intersection. This snapping occurs when the walls’ center lines are within a distance defined by the larger of the two walls’ widths and will occur even when **Object Snaps**  are turned off. See “Object Snaps” on page 110.

If the two walls in question have the same wall type and identical specifications, and are collinear, they will merge to become a single wall. See “Aligning Collinear Walls” on page 202.

When three or more walls connect to form a completely enclosed area, that area defines a room. See “Rooms” on page 229.

When walls snap together to form an intersection and **Object Snaps**  are enabled, the program joins them at their **Resize About** line, which is specified in the **General Wall Defaults** dialog. See “Aligning Walls” on page 201.

- The wall that is being drawn or edited will move, lengthen, or shorten slightly to meet the other wall.
- The other wall will not move; however, its length may be affected.

Wall Intersections

Any time two walls intersect, one wall will build through the other. You can turn on the display of the “Walls, Thru Wall Lines” layer in floor plan view to see which walls build through and which do not. See “Displaying Objects” on page 102.

When a wall builds through another wall, it will extend into the intersected wall until it meets the interior surface of that wall’s Main Layer. See “The Main Layer” on page 209.

Fix Connections



Occasionally, one or more walls do not properly connect. To clean up most connections throughout the plan, select **Build> Walls> Fix Connections**.

If you have only one connection to fix, the **Connect Walls**  edit button is faster to use.

Connect Walls



Use the **Connect Walls** edit button to complete an intersection of two walls. Select a wall, click the **Connect Walls** edit button, then click on the other wall to connect the two.

If the unconnected wall ends are sufficiently close to one another, the tool connects them. If the separation is too great, extend one towards the other and try again.

Removing Wall Breaks

The **Break Wall**  tool allows you to break a wall into two or more separate wall segments. See “Break Wall” on page 189.

To merge two collinear walls separated by a break, select one of the segments, then click on the end edit handle located at the break and drag it a few plan inches (mm) away from the break.

If the two walls do not merge, either one or both walls have been moved and they are no longer collinear, or one or both has been edited in some way and they are no longer identical. Open the **Wall Specification** dialog for each wall and determine how they differ. See “Wall Hatch Specification Dialog” on page 227.

Displaying Walls



While the structure and appearance of each wall type is controlled in the

Wall Type Definitions dialog, the display of walls in all views is controlled in the **Layer**

Display Options dialog. See “Displaying Objects” on page 102.

If a “Walls” layer is turned off, any doors and windows placed in walls on that layer will not display, either. See “Displaying Doors” on page 257 and “Displaying Windows” on page 287.

In Floor Plan View

The appearance of each wall type, including line weights and colors and wall layer fill styles, is specified in the **Wall Type Definitions** dialog. See “Wall Type Definitions Dialog” on page 211.

There are also several options for controlling how walls are displayed in floor plan view. In the **Layer Display Options** dialog, you can specify whether or not various types of walls display. Walls are placed on layers with “Walls” at the beginning of the layer name, such as “Walls, Normal”.

The display of the wall layers specified in the **Wall Type Definitions** dialog can be controlled. If you turn off the display of the layer called “Walls, Layers”, wall types display with two lines representing the inside and outside surfaces.

In addition, you can turn off the display of non-structural layers and show only the walls’ Main Layers by turning on the display of the “Walls, Main Layer Only” layer. This allows you to create both fully configured walls and framing layouts. The “Walls, Main Layer Only” layer affects the display of walls in floor plan view only. See “The Main Layer” on page 209.

The “Walls, Thru Wall Lines” layer controls the display of lines indicating which walls build through at wall intersections.

Note: In floor plan view, railings not specified as Solid display their Main Layer regardless of whether “Walls, Layers” or “Walls, Main Layer Only” is turned on. See “Wall Types and Railings” on page 186.

Foundation Walls have footings that display in floor plan view as long as the “Footings” layer is turned on. See “Displaying Foundations” on page 335.

It is sometimes helpful to display the walls from a floor other than the current floor. To do this, select and display a reference floor. See “The Reference Floor” on page 327. You can also specify which layers are included in the Reference Display Layer Set in the **Layer Display Options** dialog.

In 3D Views

As in floor plan view, the display of walls can be controlled by layer in the **Layer Display Options** dialog.

Each layer of a wall is generated when you create a 3D view. You can see the different layers in 3D using the **Delete Surface**  tool. See “Delete 3D Surface” on page 679.

A wall’s framing layer displays as a solid layer rather than studs and plates until wall framing is built. See “Framing” on page 435. Wall framing is placed on the “Framing, Wall” layer by default.

While most architectural objects in the program can display in both floor plan and 3D views, a few cannot. Invisible walls and wall hatching are examples of objects that do not display in 3D.

Wall Materials

There are several ways that materials can be assigned to walls, depending on how the walls and the rooms they define have been defined. See “Rooms” on page 229.

When you draw a wall, it uses the materials specified in its wall type definition. See “Wall Type Definitions” on page 209.

You can change the surface material of an individual wall in the **Wall Specification** dialog. If you select “Use Default” as the material and the wall is used to define a room, the program refers to the material specified in the **Room Specification** dialog. See “Wall Specification Dialog” on page 214.

You can also change a room’s wall material in the **Room Specification** dialog. See “Materials Tab” on page 635. To restore the default Wall Type material, select **Use Default** in the **Select Library Object** dialog. See “Select Library Object Dialog” on page 622.

When neither the wall nor the room has a material assigned to it, the program refers to the general material for walls in the **Material Defaults** dialog. See “Material Defaults” on page 650.

Note: Wall materials that are specified on the Materials tab of either the Wall or Room Specification dialog are not calculated in the Materials List.

Displaying Pony Walls in Floor Plan View

Either the upper or lower portion of a pony wall can display in floor plan view. Only the

portion that displays can be snapped to or aligned with walls above or below. See “Aligning Walls” on page 201.

By default, the upper portion of a pony wall displays in floor plan view. To show the lower pony wall in floor plan view instead, select **Show Lower in Plan View** in the **Pony Wall Defaults** dialog. See “Pony Wall Defaults” on page 178.

When **Object Snaps**  are enabled, you can only snap to the outer, inner and Main Layer surfaces of the part of the pony wall set to display.

Note: A window or door that is completely contained by one part of a pony wall will display in floor plan view if the other part of the pony wall is shown, but will display the wall’s layer or Hatch Wall fill patterns through it.

By default, windows and doors in pony walls are visible in floor plan view regardless of which part of the pony wall displays. You can, if you wish, select **Hide Openings in Non-Displayed Parts of Walls** in the **Pony Wall Defaults** dialog.

In the Materials List

The materials that make up wall assemblies are listed under different Categories in the Materials List:

- **Siding** - Lists all materials located outside of each wall’s Main Layer, such as siding, sheathing, and housewrap.
- **Framing** - Lists the Main Layer material for all walls as well as railings specified as Solid. Non-framed walls’ Main Layer materials are also listed here when those walls are not specified as Foundation.

Wall framing, including studs, plates, and headers, is only counted when a wall's Main Layer is a framing material and wall framing has been built. See "Framing" on page 435.

- **Insulation** - Insulation is calculated for all exterior walls that are not specified as Railing, regardless of the wall type definition.
- **Wallboard** - Lists all materials located inside of each wall's Main Layer, such as drywall. Includes all materials aside from framing, concrete, and rebar in walls that do not define rooms.

Does not include Wall Coverings or materials specified in either the **Room** or **Wall Specification** dialog. See "Materials Tab" on page 223.

- **Interior Trim** - Lists base, crown and chair rail moldings, and Wall Covering

materials specified in the **Wall** and **Room Specification** dialogs. See "Wall Covering Tab" on page 223.

- **Foundation** - Lists the concrete and rebar for all walls specified as Foundation as well as their footings. See "Foundation Walls" on page 183.

With the exception of wallboard, windows and doors are taken into account in the calculation of these totals.

Additional wall-related information is listed in the **General** category, including the total linear feet of each wall type per floor and the total heated wall area per floor.

A wall type's Main Layer plays a central role in determining how - or whether - wall materials are calculated. For this and other reasons, correct Main Layer assignment is very important. See "The Main Layer" on page 209.

Measuring Walls

Accurate wall measurements are an essential aspect of any drawing, and can be achieved by following two basic rules:

- Be aware of what part of a wall assembly dimensions are locating;
- Position walls using dimensions rather than edit handles or edit tools.

These rules can easily be met when you keep the following recommendations in mind.

Use Dimension Defaults

Manually-drawn and automatic dimensions can be set to locate walls at their Main

Layers or at surfaces. Before drawing dimensions - and particularly, before using them to move your walls into position - make sure that your Dimension Defaults are set up to meet your needs. See "Dimension Preferences and Defaults" on page 719.

Be aware, too, that the wall length dimension that displays when a wall is selected as well as the **Length** specification in the **Wall Specification** dialog do not inherit their settings from the Dimension Defaults. Instead, they follow the **Resize About** line. See "Resize About" on page 202.

Edit Dimension Lines

Once a dimension line has been drawn, its extension lines can be edited to locate a number of locations on a wall assembly:

- The exterior surface
- The Wall Dimension Layer's exterior
- The center line of the wall assembly
- The Main Layer's center line
- The Main Layer's interior
- The interior surface

See "Editing Extension Lines" on page 735.

Moving Walls Using Dimensions

By far, the most precise method of positioning walls is using dimension lines. To produce accurate measurements, remember to:

- Be aware of what part of your walls is being located by each type of dimension.
- Avoid specifying dimension values with greater accuracy than your dimensions are set to display. See "Format Tab" on page 722.

See "Using Dimensions" on page 198.

Remember that the temporary wall length dimension that displays when a wall is selected may be set to locate a different part of the wall assembly than other dimension lines. See "Wall Length" on page 200.

Use Object, Angle and Grid Snaps

Object Snaps, Angle Snaps, and Grid Snaps make it easier to align walls when they are

being drawn as well as when they are edited. See "Snap Behaviors" on page 109.



Object Snaps  help to ensure consistent wall connections and are particularly helpful when aligning collinear walls.

When **Grid Snaps**  are enabled, walls are drawn on a regularly spaced grid, which helps avoid inaccurate wall placement. This can become particularly important if you forego positioning walls using dimensions in favor of using edit handles to move them.

Angle Snaps  make it easy to accurately draw walls at regular angles, ensuring walls that are truly parallel or perpendicular to one another and separated by consistent distances.

No Locate

If a wall is specified as **No Locate** in the **Wall Specification** dialog, it will be ignored by **Auto Exterior Dimensions**  in floor plan view, as will any doors or windows placed in it. By default, **Railings**, **Deck Railings**, and **Invisible Walls** are specified as No Locate. See "General Tab" on page 214.

The **No Locate** setting also affects the behavior of **Manual Dimensions** , and **End to End Dimensions** , and **Angular Dimensions** . If a Manual or End to End Dimension is drawn between two No Locate walls, a dimension line will be created; however, if one of the walls is No Locate and one is not, no dimension line will be drawn.

Angular Dimensions  do not recognize

No Locate walls under any conditions. See “Dimensions” on page 719.

If a wall is on its default layer and is specified as **No Locate**, it will be moved to the “Walls, No Locate” layer. If this box is later unchecked, the wall will return to its default layer. If a wall is on a non-default layer, it

will remain there. See “Displaying Walls” on page 192.

Once a dimension line has been created, it can be edited so that it locates a No Locate wall or railing that is perpendicular to it.

Angular Dimensions  cannot be edited in this manner and are the exception to this statement. See [Editing Dimension Lines](#).

Editing Walls

Walls can be selected individually and as a group in all views. When a wall is selected, it displays edit handles and an edit toolbar that can be used to edit it in various ways. When a wall is selected, temporary dimensions may also display. See “Display Temporary Dimensions” on page 731.

The ways in which a wall can be edited depends on the current view and which edge is selected. See “Selecting Objects” on page 124.

Selecting Walls

- When you try to select a wall in a cross section/elevation or 3D view, the interior or exterior room that it defines may be selected first. Click the **Select Next**

Object  edit button or press the Tab key on your keyboard to select the wall itself. See “Selecting Rooms” on page 231.

You can specify that the wall be selected first instead of the room in the **Preferences** dialog. See “Appearance Panel” on page 61.

- In floor plan view, if wall hatching has been applied to a wall using the **Hatch**

Wall  tool, the hatching may be selected first. Click **Select Next**

Object  to select the wall itself. See “Hatch Wall” on page 188.

- The **Edit Area**  tools allow you to select only part of a wall or walls. See “Edit Area Tools” on page 168.

Using the Edit Handles

Depending on the type of view, a wall displays a different set of edit handles when selected.

- In floor plan view, straight and curved walls can be edited like other line- and arc-based objects. See “Editing Line Based Objects” on page 127 and “Editing Arc Based Objects” on page 130.
- In floor plan view, a wall’s edit handles display along its **Resize About** line. See “Resize About” on page 202.
- In a camera view or overview, click on the top surface of a wall to display the same edit handles as in floor plan view, allow-

ing you to rotate, move, and extend or shorten the length of the wall.

- Moving a wall in any view will move any cabinets attached to that wall, as well.
- In a cross section/elevation view, the top and bottom edges of straight and curved walls can be edited like closed polylines. See “Editing Closed-Polyline Based Objects” on page 138. Only the top and bottom edges of walls can be broken, angled or curved: the side edges cannot.
- In a camera view or overview, click on an interior or exterior surface to display the same edit handles as in an elevation view: one at each corner and one on the top and bottom edges.
- When a wall is connected to other walls and **Edit Object Parts**  is turned off, it can only be moved perpendicular to itself or, in the case of curved walls, perpendicular to its chord using the Move edit handle. Unconnected walls can be moved at Allowed Angles.
- The footings of Foundation Walls and Slab Footings can be selected in 3D views and edited using the edit handles. See “Footing Width and Height” on page 337.
- The **Same Wall Type** edit handles can be enabled, allowing you to draw a new wall segment of the same type as the selected wall.

Same Wall Type Edit Handles

When the **Same Wall Type** edit handles are enabled, two edit handles display just beyond a selected wall’s Extend edit handles in floor

plan view or when the top edge of the wall is selected in a 3D view.

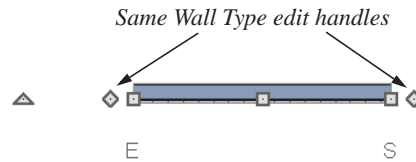

Click and drag a **Same Wall Type** edit handle at any angle to draw a new wall segment of the same type as the selected wall.

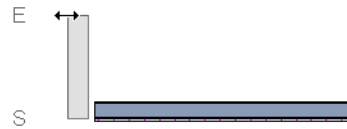

To temporarily enable the Same Wall Type edit handles, select a wall and click the **Same Wall Type**  edit button. You can also enable these handles globally in the **Preferences** dialog. See “Architectural Panel” on page 73.

In the Specification Dialog

 The appearance and structure of walls can be customized in the **Wall Specification** dialog. See “Wall Specification Dialog” on page 214.

The characteristics of the roof directly above a selected wall can also be specified in the **Wall Specification** dialog. See “Roof Tab” on page 218.

Using the Edit Tools

A selected wall or walls can be edited in a variety of ways using the buttons on the edit toolbar. See “The Edit Toolbar” on page 29.

The characteristics of the roof directly above a selected wall can also be specified in the **Wall Specification** dialog. See “Roof Tab” on page 218.

Using Dimensions

 Automatic, manually-drawn, and temporary dimension lines can be used to both resize and move walls with accuracy. Select a wall, then click on a dimension line that locates it and type in the value that you need. See “Moving Objects Using Dimensions” on page 737.

When a wall is resized using dimensions, the inline text field used to edit the dimension will have three unique buttons: **Move Start**, **Move End**, and **Move Both Ends**. Choose the option that you want to use before pressing the Enter key.

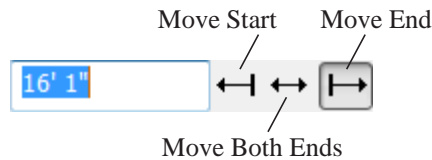

If both ends of the selected wall intersect walls that are not parallel to one another, a fourth option will be available: **Move Along Rails** . When this option is used, the selected wall both resizes and changes position so that it remains connected to the other walls when you press the Enter key.

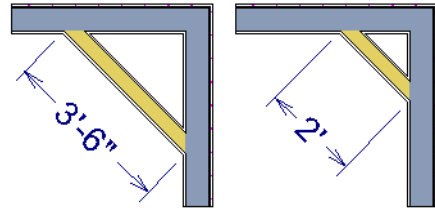

Move Along Rails resizes and moves a selected wall.

Depending on your **Dimension Defaults** settings, manual and/or automatic dimension lines may locate wall surfaces or wall dimension lines. See “Locate Objects Tab” on page 723.

 Dimension Defaults and Temporary Dimension Preferences settings can have a significant effect on wall position. It is recommended that you review these settings and make sure that they meet your needs.

Wall Thickness

The initial thickness of a wall is determined by its wall type definition. You can change a wall's thickness by modifying the definition of its wall type. If you do this, all instances of the wall type used in the plan will be affected - not just an individual object. See “Wall Type Definitions” on page 209.

You can also specify a selected wall's thickness in its **Wall Specification** dialog. See “General Tab” on page 214.

If a selected wall's thickness is changed:

- A copy of the wall's wall type is created with the same name but appended with a number equal to the thickness of the Main Layer, and that new type is assigned to the wall. See “The Main Layer” on page 209.

- The change in thickness will be applied to new wall type's Main Layer.
- The Main Layer must be at least 1/16" thick, and the wall's thickness cannot be less than the original wall type's total thickness minus the thickness of its Main Layer.

If a wall type's thickness is modified, the wall will resize about the **Resize About** line specified in the **General Wall Defaults** dialog. In some instances, the wall may appear to move as a result of changes made to the thicknesses of its layers. See "General Wall Defaults" on page 176.

Wall Heights

The height of a wall is controlled by the ceiling height of the room(s) it defines. If the ceiling or floor height of a room is changed, the height of the walls that define it also change.

- The initial ceiling height for all rooms on a floor is set in the **Floor Defaults** dialog for that floor. See "Floor Defaults" on page 230. Whenever possible, it is best to set all ceiling heights using the default.
- The ceiling height of a single room can be set in its **Room Specification** dialog. See "General Tab" on page 244.
- The default Floor and Ceiling Heights for a given floor can be adjusted by editing the top and/or bottom edges of the Exterior Room in a 3D view. See "The Exterior Room" on page 232.
- If the wall height of the Exterior Room is adjusted in a 3D view, the default Floor or Ceiling Height of the entire floor is changed. See "The Exterior Room" on page 232.

- The top or bottom edge of any wall can be adjusted independent of floor or ceiling heights using the mouse in Cross Section/Elevation and 3D views. Top and bottom edges can also be stepped and raked. See "Stepped and Raked Walls" on page 207.
- The edge dividing an upper and lower pony wall can be edited in Cross Section/Elevation and 3D views. In addition, its height can be defined in the **Wall Specification** dialog. See "Wall Types Tab" on page 221.

Wall Length

Wall length can be modified in several different ways:

- Using dimensions. See "Measuring Walls" on page 195.
- In the **Wall Specification** dialog. See "General Tab" on page 214.
- By dragging the end edit handles. See "Editing Line Based Objects" on page 127 and "Editing Arc Based Objects" on page 130.

Bear in mind that if you try to resize a wall by a small amount using one of its edit handles and that wall is connected to another wall at that end, its length will not change because its end will snap back to the existing intersection. See "Connecting Walls" on page 191.

The most accurate way to specify wall length is using dimensions. By default, wall length is measured at the outside edge of the Main Layer. You can instead specify that manual and/or automatic dimension lines locate surfaces in the **Dimension Defaults** dialogs. See "Dimension Preferences and Defaults" on page 719.

Be aware that the wall length dimension that displays when a wall is selected as well as the **Length** specification in the **Wall Specification** dialog do not inherit their settings from the Dimension Defaults. Instead, they follow the **Resize About** line. See “Resize About” on page 202.

Note: By default, dimensions and the Resize About line all use the exterior edge of the Main Layer. When Resize About is set to use a different location, dimension lines may not agree with a wall's length specification. See “Measuring Walls” on page 195.

Editing Straight/Curved Wall Combinations

If you move a straight wall connected to a curved wall with a locked center and the connection cannot be maintained without changing the center of the arc, the walls lose their connection.

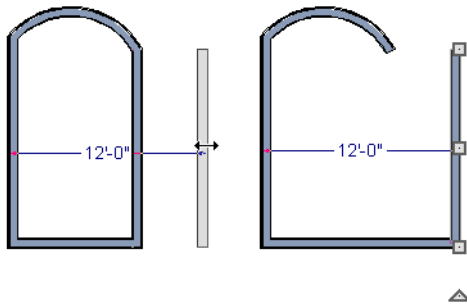

When an Extend edit handle of a curved wall with a locked center is dragged with the **Alternate** **Alt** Edit Behavior active, the

locked center setting will be overridden. See “Edit Behaviors” on page 120.

If you move a straight wall connected to a curved wall with a locked center, the curved wall extends along its curve and the straight wall will either lengthen or shorten as needed to stay connected to the curved wall.

If the connection between the straight and curved wall cannot be maintained because of the curved wall's radius, it will be broken.

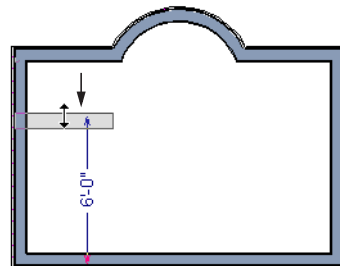

Aligning Walls

Wall alignment refers to the way wall segments line up with one another, either on the same floor or on the floor above or below. Walls may need to be aligned in a variety of situations.

To make alignment easier when drawing or resizing walls, “sticky” points and extension lines identify points that are either collinear or orthogonal to the end points of other walls. See “Extension Snaps” on page 111.

Resize About

The **Resize About** line specified in the **General Wall Defaults** dialog controls two important aspects of wall alignment:

- What part of a wall retains its position when its wall type or wall type definition is changed. See “Wall Type Definitions” on page 209.
- Where walls snap together to form an intersection. See “Connecting Walls” on page 191.

The **Resize About** line is the line along which a selected wall’s length is measured in the **Wall Specification** dialog. See “Wall Length” on page 200.

The **Resize About** line is also the line along which a selected wall’s edit handles display, and is the line along which any snap points will be located. See “Editing Walls” on page 197.

Aligning Collinear Walls

Collinear walls are parallel walls connected end to end and drawn on the same floor. When collinear walls join end-to-end, the walls snap together. If these walls have the same wall type and identical specifications, and if **Object Snaps**  are enabled, they will merge to become a single wall segment.

Creating a Nook

Walls can be aligned across an opening such as a nook, so that they are collinear, using the **Break Wall**  tool.

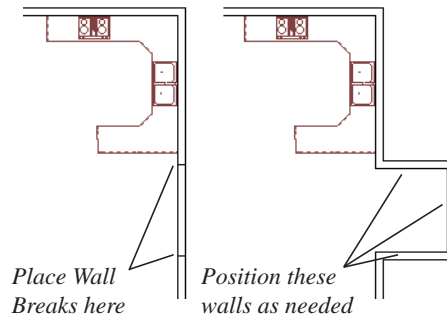

To align walls across a gap

1. Select a wall to build a nook into and click the **Break Wall**  edit button.
2. Click at a point on the wall close to one side of the nook area. Do not worry about exact placement right now.
3. Click again near the other side of the nook. Two short lines at each location where you clicked indicate Wall Breaks.



4. Right-click the middle section of the wall to select the wall section.
5. Click the middle Move handle and drag the wall outward.
6. Draw side walls to connect the wall back to the rest of the house.
7. Move these short walls using dimensions to accurately size the nook.

Aligning Walls Between Floors



Walls can be aligned between floors by clicking the **Align With Wall Above**  and **Align With Wall Below**  edit buttons.

By default, walls on different floors are aligned by the outer edges of their Main Layers. See “The Main Layer” on page 209.





In order for these edit tools to be available, the areas of the walls in question must be partially aligned, or overlapping.

To align walls between floors



1. Select a wall that you want to align with another wall either above or below it.
2. If the wall is above or below the other wall along only part of its length, you must click on it along that part. Select **Tools > Reference Floors > Reference Display On**  to help make sure you click on the correct part of the wall.
3. When you have selected the wall at the desired location, click either the **Align With Wall Above**  or **Align With Wall Below**  edit button.

Aligning Curved Walls Between Floors

Curved walls are aligned between floors using the same technique to align straight walls. If the centers and radii of the walls are within a few inches of each other, the **Align With Wall Above**  and **Align With Wall Below**  edit buttons are enabled for the selected wall. The selected curved wall will take on the radius and center of the referenced wall when the walls are aligned.

Aligning Pony Walls Between Floors

When aligning a pony wall with either the wall above or below:



- **Align With Wall Below**  will always align the lower pony wall with the wall below, as specified in the lower pony wall’s Wall Type Definition. See “Wall Type Definitions” on page 209.
- **Align With Wall Above**  will always align the upper pony wall with the wall above, as specified in the upper pony wall’s Wall Type Definition.

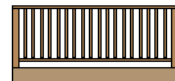

Aligning Railing on Different Platforms

Two collinear Railings or Deck Railings on the same floor can be aligned one above the other when they define rooms with different floor heights.



To align railing on different platforms

1. Click and drag to draw a Railing or Deck Railing that divides a room such as a deck in two.
2. Click the **Select Objects**  button, then click in one of the room areas.
3. Click the **Open Object**  edit button, and on the General tab of the **Room Specification** dialog:

- Specify a **Floor Height** that differs from that of the other by at least the height of the railing, then click OK.
 - The default railing height is 36”, so for best results the Floor Height should be changed by at least this amount.
4. Click on the railing drawn in step 1, then click the **Open Object**  edit button. On the Rail Style tab of the **Railing** or **Deck Railing Specification** dialog, check **Generate on Low Platform**. See “Rail Style Tab” on page 224.
 5. Click and drag a second railing parallel to the one drawn in step 1.
 6. Select this second railing and click the **Open Object**  edit button. On the General tab of the **Railing** or **Deck Railing Specification** dialog, check the box beside **No Room Def** and click OK.
 7. With the railing still selected, Ctrl + drag it into the same position as the first railing. See “To move an object freely” on page 153.

Roof Directives in Walls

To automatically generate a roof plane using values other than the defaults or to not generate a roof plane bearing on a particular wall (as for a gable or the sides of a shed roof), you can change the settings in the **Wall Specification** dialog. See “Roof Tab” on page 218.

Hip, Gable, and Shed Roofs

By default, the program will produce a roof plane over each exterior wall to create a hip roof. You can instead specify a gable or shed roof above the selected wall.

- Check **Full Gable Wall** to create a gable with a ridge centered above the selected wall(s).
- Check **High Shed/Gable Wall** for the side walls or the wall under the high side of a shed roof.
- You can also select a wall and click the **Change to Gable Wall(s)**  edit button,

or change it back by clicking the **Change to Hip Wall(s)**  edit button.

Pitch

The default pitch for roof planes is set in the **Build Roof** dialog. However, any exterior wall can define the pitch of the roof plane built above it.

You can also specify a second, upper pitch above a given wall. Mansard, gambrel, gull wing and half-hip are examples of roof styles that use two pitches. See “Roof Tutorial” on page 69 of the User’s Guide.

Overhangs and Roof Returns

You can specify the overhang of the roof plane to be generated above the selected wall. This setting only takes effect when Same Height at Exterior Walls is unchecked in the the **Build Roof** dialog, which is also where the default Overhang value is set.

Check **Auto Roof Return** to generate roof returns on the selected wall. In most cases, roof returns only generate on Full Gable Walls. See “Roof Returns” on page 393.

Extend Slope Downward

Check **Extend Slope Downward** to extend the roof plane downward over a bumpout, instead of creating additional roof planes. The two connecting walls that create the bumpout must be Full Gable walls.

In the following image, the bearing wall of the bumpout has **Extend Slope Downward** checked. The two short side walls are **Full Gable Walls**.

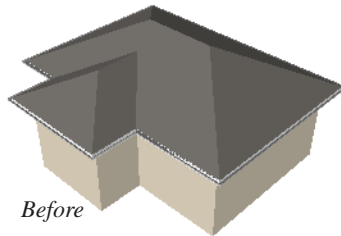

Before

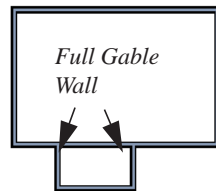

Extend Slope Downward

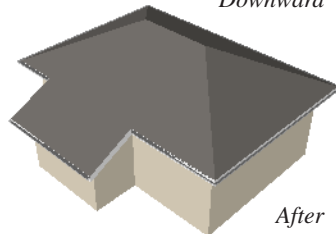

After

Clerestory and Dormer Walls

Occasionally, walls are built between two roof planes rather than between a roof plane and a floor platform. Common examples include clerestory walls and the side, or the cheek, walls of floating dormers.

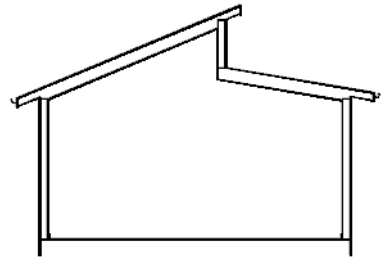

Clerestory wall built between two roof planes

Check **Roof Cuts Wall at Bottom** to have the bottom of the selected wall clipped by the roof plane below, as where a floating dormer wall meets the main roof plane.

Exterior/Interior Pony Walls

It's not uncommon for an individual wall to be an exterior wall near its top, and an interior wall near its bottom.

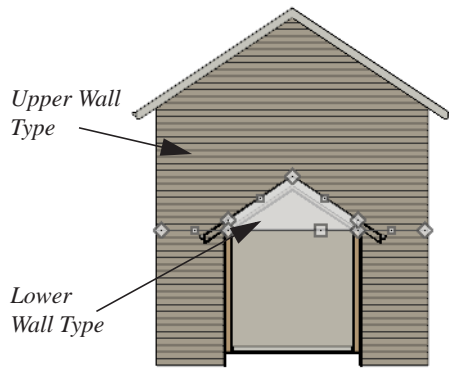

Lower Wall Type If Split By Butting Roof

Check **Lower Wall Type If Split By Butting Roof** to achieve this. When this option is checked, the selected wall is specified as a

pony wall and a second, lower wall type can be specified. Unlike with other pony walls, the change in wall type occurs wherever a roof plane builds to the exterior of the wall. See “Pony Walls” on page 184.

Attic Walls

In Home Designer Pro, walls are built between the floor and ceiling platforms of the current floor. See “Floor & Ceiling Heights” on page 239. When the program detects an open space between a wall and the roof plane above it, it automatically creates an Attic Wall on the floor above that wall to fill in the gap.

Attic Walls are typically found above Full Gable Walls, forming a gable or closing the top portion of a side wall of a shed roof. They are also generated above all exterior walls when the **Raise Off Plate** value in the **Build Roof** dialog is 3” (175 mm) or greater. See “Build Roof Dialog” on page 355.

Attic walls are often found on the Attic floor, but can be generated on other floors, as well. See “The Attic Floor” on page 327.

You can eliminate an existing Attic wall by combining it with the wall below it. To do this, select **Combine with Above Wall** in the **Wall Specification** dialog for the wall below. See “Roof Tab” on page 218.

Attic Walls are specified as such in the **Wall Specification** dialog. If needed, you can specify a regular wall as an Attic Wall. See “General Tab” on page 214.

When you **Rebuild Walls/Floors/**

Ceilings , all Attic Walls in the plan are deleted and rebuilt.



Knee Walls

Knee Walls are a bit like Attic Walls in that they are not meant to generate to full ceiling height. Instead, they build upward until they encounter a roof plane. Unlike Attic Walls,

however, Knee Walls are used in the interior of a structure, typically to separate unused areas from rooms on the upper floor of a story-and-a-half structure. See “Room Types” on page 234.

Home Designer Pro does not specify walls as Knee Walls automatically. If an interior wall is drawn in a location where the roof is lower than the ceiling height, you should specify it as a Knee Wall in the **Wall Specification** dialog. See “Roof Tab” on page 218.

Stepped and Raked Walls

Stepped and raked walls can be created using the **Break Line**  tool and the wall's edit handles in any 3D or Cross Section/Elevation view. In many cases, working in a **Back-clipped Cross Section**  is easiest and allows the greatest accuracy.



 When you try to select a wall in a 3D view, the interior or exterior room that it defines may be selected first. Click the Select Next Object edit button to select the wall itself. See “Selecting Walls” on page 197.

Stepped Walls & Footings

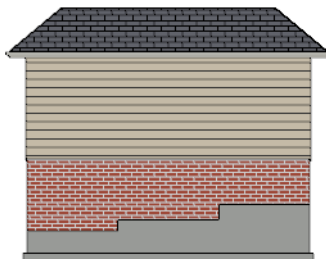
A typical example of stepped walls is a stepped foundation with pony walls. In the illustration below, the lower part of the pony wall is the concrete wall with footing, and the upper part of the pony wall is a framed wall with brick siding built to the first floor platform. See “Pony Walls” on page 184.



To add a step to a wall

1. Select the wall in a **Backclipped Cross Section**  view.
2. Click the **Break Line**  tool, then click the top or bottom edge of the wall to place the break.
3. In addition to the corner handles, two handles display along the broken edge.
4. Select one of these two handles, and drag up or down.
5. A square step is created.

The vertical edges of a wall cannot be broken, although they can be raked as well as moved side to side.



By default, a stepped foundation wall displays an “S” symbol at the location of each step in floor plan view. The display of this “S” is controlled in the **Foundation Defaults** dialog. See “Foundation Tab” on page 331.

Raked Walls

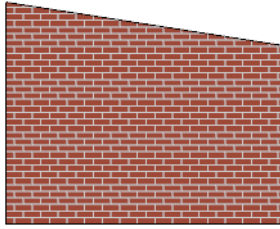
A raked wall has an angled top or bottom edge.



To create a simple raked wall

1. Select the wall in Cross Section/Elevation or 3D view.
2. Click one of the corner edit handles and drag that handle either up or down.
3. To rake a wall at a specific angle, you can:
 - Use Angle Snaps  and Allowed Angles. See “Angle Snaps” on page 111.
 - Draw a CAD Line  at the desired angle and use the **Make Parallel/Perpendicular**  edit tool. See

“Using Make Parallel/Perpendicular” on page 155.

Compound Raked Walls

A compound raked wall is a wall that has a top or bottom edge with multiple angles.

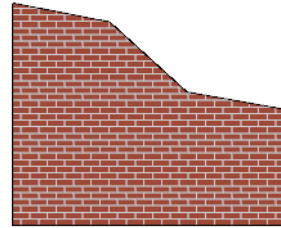

To create a compound raked wall

1. Select the wall in Cross Section/Elevation or 3D view.
2. Use the **Break Line**  tool to add breaks to the wall edge, as for a stepped wall.
3. Select a segment of the edge and adjust its angle, as for a raked wall.

CAD to Walls



The **CAD to Walls** tool can be used to convert CAD lines in floor plan view into architectural objects. Two or more parallel CAD lines can be converted to both straight or curved walls or rails. CAD lines representing windows and doors can also be converted.

All lines that you want to convert to walls must be located on one layer. The same is true for windows, doors, and rails. See

“Layer Display Options Dialog” on page 104.

To convert the lines of an imported drawing using **CAD to Walls** , map its layers in the **Import Drawing Wizard**. Do not check “Boxes” or “Polylines”. See “Select File” on page 830.

When CAD objects are located properly, select **CAD > CAD to Walls**  to display the **CAD to Walls** dialog.

Convert CAD to Walls Dialog

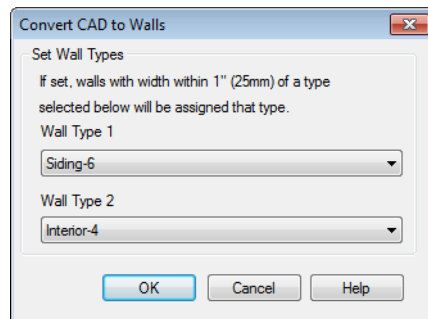

Specify wall types for the new walls. One, two, or neither can be specified.

To convert to a specific wall type, the lines must be within one inch or 25mm of that wall type's width. If two wall types are specified,

new walls are converted to the one having the closest width. The new wall expands or contracts about its centerline to reach the width of the wall type. Typically, only two wall types are used in a plan and an interior and exterior wall type are specified.

Conversion works better if lines representing windows and doors are on different layers, although it may still be satisfactory if they are on the same layer. In either case, the arc indicating door swing helps to identify a door and should be placed on the same layer as doors.

Click **OK** to complete the conversion. Converted items are found in the **Layer Display Options** dialog.

Wall Type Definitions

Every wall drawn in a plan is assigned a wall type, and its Wall Type Definition determines its structure, its appearance in floor plan view, and its default materials.

Material information in the Wall Type Definition can be calculated for take-offs in the Materials List. See “Materials Lists” on page 887.

Wall types can be viewed, edited and created in the **Wall Type Definitions** dialog. See “Wall Type Definitions Dialog” on page 211.

Walls can have up to ten layers defined, each representing a different material. All of these layers can be calculated in the Materials List. Materials that are applied to the outer layers of the wall type definition also determine the wall's appearance in 3D views.

You can specify the default wall types used when walls are first created, and can specify the wall type of any wall after it is drawn in the **Wall Specification** dialog. See “Wall, Railing, and Fencing Defaults” on page 176 and “Wall Types Tab” on page 221.

The Main Layer

In most circumstances, the Main Layer should be specified as the structural layer of the wall, particularly when the wall is a framed type. The Main Layer determines many things, including:

- Floor and ceiling platforms and automatically built foundation walls normally build to the outer edge of the Main Layer.

- At intersections, walls join at the interior surfaces of their Main Layers. See “Connecting Walls” on page 191.
- Exterior walls on different floors are aligned by the exterior edges of their Main Layers.
- Roof baselines are placed at the outer edge of the Main Layer when roofs are automatically generated. See “The Baseline” on page 363.
- Roof base lines and gable/roof lines that are manually drawn snap to the edge of this layer.
- When wall framing is generated, stud depth is based on the thickness of each wall’s Main Layer.
- By default, walls resize about the exterior surface of their Main Layer when their wall type or Wall Type Definition is changed. See “Resize About” on page 202.
- By default, Object Snaps  locate the exterior surface of a wall’s Main Layer. See “Object Snaps” on page 110.

 Wall framing will only generate in a wall when a Framing material such as Fir Stud 16” OC or Metal Stud 24” OC is specified for its framing layer. See “Material Types” on page 640.

All of this information is reliant on the Main Layer, so creating your wall type definitions accurately beforehand and specifying the Main Layer is very important.



The Dimension Layer

Dimension Defaults can be set to locate walls at their surfaces or at the exterior line of their

Wall Dimension Layer. See “Locate Objects Tab” on page 723.

The Main Layer is the default Wall Dimension Layer for installed wall types; however, this can be changed if need be in the **Wall Type Definitions** dialog. In addition to the Wall Dimension Layer, the program will locate the inside surface of the Main Layer, as well.

Whether Surface or Wall Dimension Layer is selected on the Locate Objects tab of the **Dimension Defaults** dialog determines a number of aspects related to how dimensions locate walls:

- How Auto Exterior and Manual Dimensions measure the lengths of walls.
- Where both Manual and Automatic Reach are measured from.
- Where Extension line lengths and their Gap From Marked Object are measured from.
- Where First Line Offset for **Auto Exterior Dimensions**  is measured from.
- How the minimum enclosed area required by **Auto Exterior Dimensions**  is measured.

The settings on the Locate Objects tab control how dimensions initially locate walls. Once a dimension line has been created, you can move its extension lines or add new extensions to locate other points along a wall’s assembly. See “Measuring Walls” on page 195.

Interior and Exterior Surfaces

Every wall has an interior and exterior surface - including walls in a plan that are

recognized by the program as being interior walls. See “Exterior and Interior Walls” on page 183.

Having separate designations for a wall’s two surfaces allows you to specify different materials for each in the **Wall Specification** dialog. See “Materials Tab” on page 223.

In the **Wall Type Definitions** dialog, the exterior surface is shown at the top of the wall assembly diagram. In floor plan view, you can identify a selected wall’s exterior surface by the location of its edit handles, which display on the exterior of the Main Layer by default. See “Resize About” on page 202.

Legacy Wall Types

In Home Designer Pro version X2 and prior, generic, single-layer wall types were used as the default for railings, deck railings and fencing. In the earliest program versions, they were the defaults for walls, as well.

- In Home Designer Pro X1 and prior, there were two such wall types: “Default (wood frame 16”OC)” and “Default (concrete)”.
- In Home Designer Pro X2, these two wall types were replaced by one named “Adjustable Thickness Wall”.

When plans that include either of these wall types - in the drawing itself or set as a default - are opened in Home Designer Pro 2014, the

legacy wall type is replaced by a new wall type named “Wall-X”, where X is the thickness of the wall’s Main Layer, rounded up. There are a few exceptions:

- If legacy wall types with the same thickness but different materials are found, they use the same naming convention appended with and additional **_X**.
- If a wall using a legacy wall type is specified as a Foundation wall, the resulting wall type will be named “Foundation Wall-X”.
- If a legacy wall type has the same attributes as a wall type installed with Home Designer Pro 2014, such as 8” Concrete Stem Wall, it will be replaced by that wall type.

Unless a wall is specified as a Foundation wall, Deck Railing, or Fencing, it will be treated as a framed wall and its new wall type will acquire two additional 1/2” (13 mm) thick wall layers: an interior and an exterior layer. These new layers will use the interior and exterior materials of the original wall. The wall’s original layer will maintain its original thickness, acquire a framing material, and will become the new wall type’s Main Layer.

Foundation, Deck Railing, and Fencing wall types converted in this manner will continue to have only one layer.

Wall Type Definitions Dialog



The **Wall Type Definitions** dialog is used to define new wall types and redefine existing wall types in the current

plan file. Select **Build> Wall> Define Wall Types** to open this dialog.

You can also click the **Define** button on the Wall Types tab of the **Wall Specification** or

in most **Wall Defaults** dialogs. See “Wall Types Tab” on page 221.

Changes made to an existing wall type definition affect all walls in the current plan using that wall type. Walls in other plan files are unaffected.

If changes to a wall type affect its thickness, the position of any walls in the plan using that wall type may be affected. See “General Wall Defaults” on page 176.

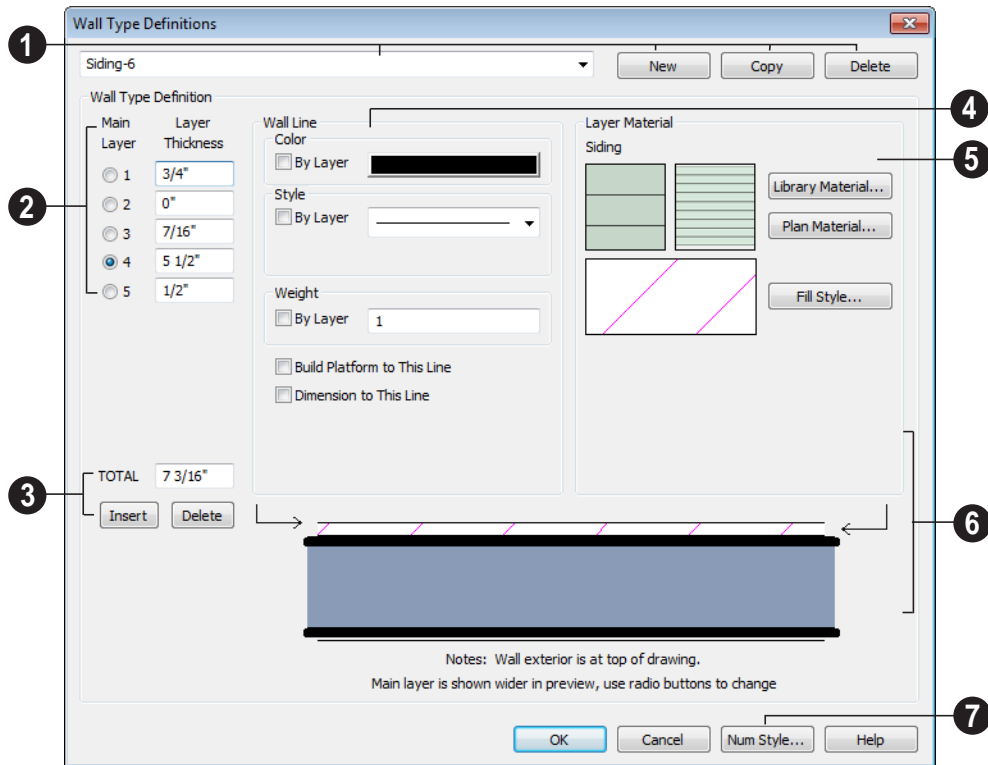

- 1 Manage the list of wall types available in the current plan.
- Click this drop-down list to display all available wall types in the current plan. Select a wall type from the list to display its definition. You can rename a wall type by typing in a new name.

- To create a new wall type, click **New** to define a new wall type from scratch or click **Copy** to copy the current wall type. A copied wall type can then be renamed and redefined.
- To remove a wall type, select it and click **Delete**. Wall types currently being used in your plan or set as plan defaults cannot be deleted.

- 2** The selected wall type's layers are listed here.
- Wall layers are numbered and are listed from exterior at the top to interior at the bottom.
 - If the selected wall type has multiple wall layers, select a radio button to specify the **Main Layer**. The Main Layer is usually the structural layer and is often thicker than other layers.
 - Define the **Thickness** for each wall layer. Very thin layers can be created, but for best results, avoid using a thickness of 0. The number format can be changed by clicking the Num Style button.
 - To select a layer for editing, click in its Layer Thickness text field. The arrow to the right of the wall assembly diagram points to the selected layer, while the arrow to the left of the diagram points to its exterior surface.



You can also select a wall layer by clicking on it in the wall assembly diagram at the bottom of the dialog.

- 3** Manage the layers associated with the selected wall type definition.
- The **TOTAL** thickness of the wall type definition displays here. If you change this value, the thickness of the Main Layer automatically updates to account for the difference.
 - Click the **Insert** button to create a new layer directly above the selected layer in the wall type definition.
 - To insert a layer at the bottom, or interior, of the wall type definition, click on the

bottom line in the wall assembly diagram and then click the **Insert** button.

- Click **Delete** to remove the selected layer from the wall type definition.
- 4** Specify the attributes of the selected **Wall Line**. Wall Lines define the extents of the layers in the wall assembly diagram at the bottom of the dialog. To select a Wall Line for editing, simply click on it in the diagram. The arrow to the left of the diagram points to the selected line.
- Define the **Color**, **Style**, and **Weight** for the selected Wall Line.
 - Check **By Layer** if you want the line to assume the attributes of the wall's layer as defined in the **Layer Display Options** dialog. See "Displaying Objects" on page 102.
 - Check **Build Platform to This Line** to build floor and ceiling platforms to the selected Wall Line. This option can only be selected for one Wall Line at a time. By default, this option is checked for the exterior side of the Main Layer.

Note: If Floor Platform to This Line is checked for the exterior surface line of the wall type, no siding material will generate to cover the floor platform.

- Check **Dimension to This Line** to have dimensions locate the selected Wall Line. This option can only be selected for a single wall layer, and can only be selected for the Main Layer or a layer located between the Main Layer and the exterior surface. By default, this option is checked for the Main Layer. Does not affect Interior Dimensions. See "The Dimension Layer" on page 210.

5 Specify the **Layer Material** for the selected wall layer, which is calculated in the Materials List, as well as the layer's fill pattern, which displays in floor plan view.

- Click the **Library Material** button or either of the two material preview boxes to open the **Select Library Object** dialog and choose a material for the selected wall layer. See “Select Library Object Dialog” on page 622.
- Click **Plan Materials** to open the **Plan Materials** dialog and choose a material for the selected wall layer. See “Plan Materials Dialog” on page 642.
- Click the **Fill Style** button to open the **Layer Fill Style** dialog and specify a fill style for the selected wall layer. This dialog is similar to the Fill Style tab for CAD objects. See “Fill Style Tab” on page 792.
- Wall layer fill styles are overridden if you use the **Hatch Wall**  tool on a wall in floor plan view.

6 An assembly diagram of the selected wall type definition displays here. Any changes made in this dialog display in the diagram, which illustrates how the wall displays in floor plan view. See “Displaying Walls” on page 192.

- The arrow to the left of the diagram points to the selected Wall Line. Wall Lines define the extents of each wall layer. To select a Wall Line, simply click on it.
- The arrow to the right of the wall assembly diagram points to the selected layer. To select a layer, click on a layer in the diagram or click in its **Thickness** field.

7 Click the **Num Style** button to open the **Number Style/Angle Style** dialog.

Here you can change the numbering format. See “Number Style/Angle Style Dialog” on page 89.

Wall Specification Dialog



To open the **Wall Specification** dialog, select a wall or group of walls and click the **Open Object** edit button.

The tabs of the **Wall Specification** dialog are also found in the **Railing**, **Deck Railing**, and **Fencing Specification** dialogs. See “Railing and Fencing Specification Dialogs” on page 224.

The settings in this dialog are also similar to those in the various **Wall Defaults** dialogs. The settings in these defaults dialogs determine the initial characteristics of railings, deck railings and fencing when they are first drawn. See “Wall, Railing, and Fencing Defaults” on page 176.

General Tab

The settings on the General tab determine the basic use of the selected wall, as well as its length, angle, and other attributes.

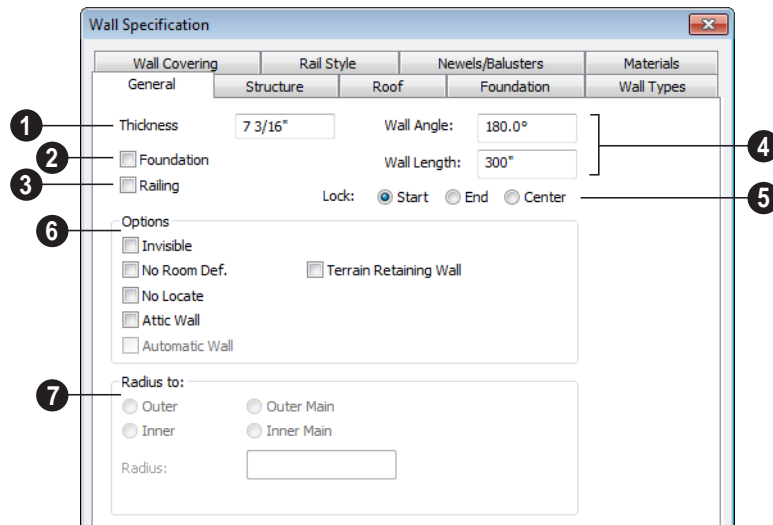

Some items on the General tab are available only when they apply to the selected wall(s) or railing(s).

- 1** The **Thickness** of the selected wall displays and can be changed here. If the wall is a Post to Overhead Beam railing, this setting also affects the width of the beam. See “Wall Thickness” on page 199.
- 2** Check **Foundation** to specify the selected wall as a foundation wall. More foundation wall settings are available on the Foundation tab.
- 3** Check **Railing** to specify the selected wall as a railing. More railing settings are found on the Railing and Newels/Balusters tab.
- 4** Specify the **Wall Angle** and **Wall Length** of a straight wall. These options are not available for curved walls.

- **Wall Angle** - The current absolute angle of the wall in a floor plan view is shown. Type in a new angle to rotate the wall about its locked point. See “3D Drafting” on page 25.
- **Wall Length** - The current length, as measured along the **Resize About** line, is shown. Type in a new length. The part of the wall that extends or contracts is determined by where it is locked. See “Resize About” on page 202.
- 5** Select a radio button to **Lock** the selected straight wall at its Start, End or Center. When the **Wall Angle** or **Wall Length** of the selected wall is changed, this point along the wall does not move. Not available for curved walls.
- 6** Check any of the **Options** to modify the selected wall accordingly. In most cases, multiple options can be selected.

- Check **Invisible** to specify the wall as invisible. Invisible walls can display in floor plan view but not 3D views and are used to divide rooms areas not separated by a wall or railing. Unless the wall is on a non-default layer, it will be moved to the “Walls, Invisible” layer when this box is checked. See “Invisible Walls” on page 187.



Select Railing and Invisible to place walls where there is a vertical break in the floor or ceiling level at the invisible wall's location. If railing is not selected, there will be a gap where the levels change.

- Check **No Room Def.** to display the wall in floor plan and/or 3D views but not create room definition. See “Room Definition” on page 231.
- Check **No Locate** to prevent **Auto Exterior Dimensions**  from locating the wall in floor plan view. See “No Locate” on page 196.
- Check **Attic Wall** to prevent the wall from extending through the roof above. Unless the wall is on a non-default layer, it will be moved to the “Walls, Attic” layer when this box is checked. See “Attic Walls” on page 206.

- **Automatic Wall** displays for reference and is checked whenever the selected wall was generated by the program. Typically, automatic walls are also Attic walls.
- Select **Terrain Retaining Wall** to treat the wall as a terrain retaining wall. See “Retaining Walls” on page 550.

7 Radius To - This section is only active for curved walls and controls the definition of the curved wall radius.

- Select **Outer** to define the radius from the center of the curved wall to the outer surface of the wall.
- Select **Inner** to define the radius from the center of the curved wall to the inner surface of the wall.
- Select **Outer Main** to display or modify the radius from the center of the curved wall to the outside of the main layer of the wall.
- Select **Inner Main** to define the radius from the center of the curved wall to the inside of the main layer of the wall.
- **Radius** - Displays the radius length as defined by the above radio buttons. Modify this value to change the curvature of the wall.

Structure Tab

The settings on the Structure tab control the height and other structural attributes of the selected wall(s).

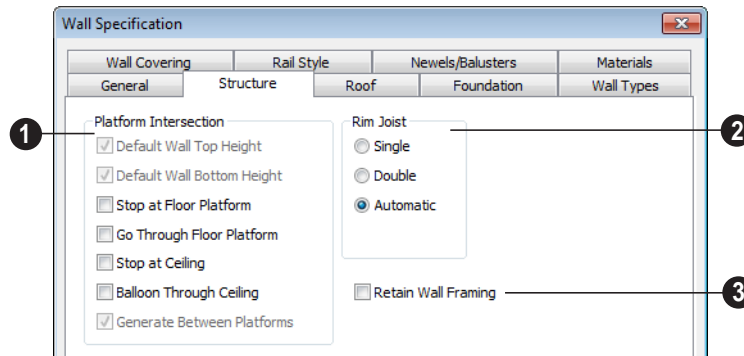

- 1** The **Platform Intersection** settings control the relationship between the selected wall and the floor and ceiling platforms above and below it.
- **Default Wall Top Height** and **Default Wall Bottom Height** are enabled if the selected wall top and/or bottom height has been edited. Check these boxes to restore the default heights.
 - Select **Stop at Platform** to have the bottom of the wall stop at the top surface of a floor platform. This is the default for framed wall types.
 - Select **Go Through Platform** to have the bottom of the wall go through a floor platform. If there is a wall directly below, the framing will continue downward to its top plate. This is the default for concrete wall types. Does not affect interior walls.

Whether a wall is a framed or concrete type is determined by material assigned to its Main Layer. See “Wall Type Definitions Dialog” on page 211.

- Select **Stop at Ceiling** to have the top of the wall stop at the bottom of a ceiling platform.

- Select **Balloon Through Ceiling** to have the top of the wall go past the ceiling platform. If there is a wall directly above, the framing will continue upward to its bottom plate. The two walls remain separate objects on different floors, however, unless the wall above is an Attic Wall. Does not affect interior walls.
 - Select **Generate Between Platforms** to fill in the gap between floor and/or ceiling platforms when the selected railing or invisible wall separates rooms with different floor and/or ceiling heights. When unchecked, this gap is not closed. Only available for railings, invisible railings, and invisible walls. See “Stepped Floor & Ceiling Platforms” on page 321.
- 2** Specify the number of **Rim Joists** for the floor platform below the selected wall(s). See “Framing” on page 435.
- Select **Single** or **Double** to generate one or two rim joists, respectively.
 - Select **Automatic** to generate two rim joists if there is no wall below the selected wall, and one rim joist when there is a wall below. Automatic produces a single rim joist for Deck Railing.

- 3 Check **Retain Wall Framing** to preserve the framing of the selected wall when the wall framing is globally

rebuilt. See “Keeping Framing Current” on page 461.

Roof Tab

Any automatically generated roof style other than a hip requires roof information to be defined in the exterior walls. On the Roof tab, you can specify how the selected wall

interacts with the roof plan, defining the portion of the roof plan that bears on it. See “Automatic vs. Manual Roofs” on page 350.

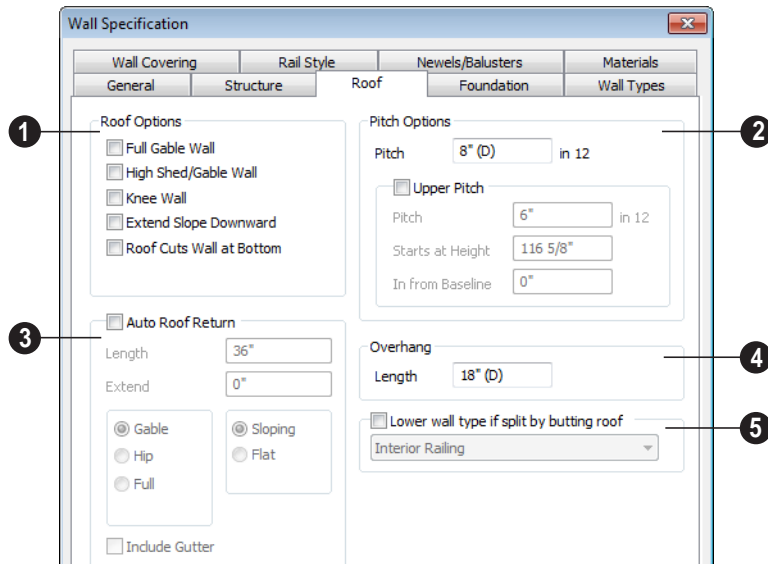

- 1 **Roof Options** - Specify the shape of the wall relative to the roof.
 - Check **Full Gable Wall** to create a gable end over the selected wall.
 - Check **High Shed/Gable Wall** to specify the selected wall as the high end of a shed roof.
 - Check **Knee Wall** to define the selected interior wall as a knee wall. Only an interior wall can be defined as a knee wall. A knee wall’s height is defined by the roof

- Check **Extend Slope Downward** to continue a roof down over a bumpout in an exterior wall. See “Extend Slope Downward” on page 205.
- Check **Roof Cuts Wall at Bottom** to prevent the portion of a selected wall located below an intersecting roof plane from building.

- **Combine with Above Wall** is only available when a selected wall has an Attic wall above it. Check this box to balloon frame the two walls when automatic framing is built. The two walls remain separate objects. See “Attic Walls” on page 206.

- 2 **Pitch Options** - Specify the pitch or pitches of the roof plane(s) above the selected wall.
 - Enter a value to define the **Pitch** of the roof plane bearing on the selected wall.
 - Check **Upper Pitch** to create a roof with two pitches or, if the selected wall is a Full Gable Wall, a half hip condition.
 - Enter the **Pitch** of the second, upper roof.
 - Specify the **Height** that the Upper Pitch **Starts at**, or define the distance **in from Baseline** that the second pitch begins. The two values are dynamic. Press the Tab key to update the relative numbers.
- 3 Check **Auto Roof Return** to generate roof returns on the selected wall. In

most cases, roof returns only work for Full Gable Walls. See “Roof Returns” on page 393.

- Specify the horizontal **Length** of the roof return in inches.
 - Enter a value in inches to **Extend** the roof returns from the overhang.
 - Specify a **Gable, Hip, or Full** roof return. Specify a **Sloping or Flat** roof return. See “Roof Tutorial” on page 69 of the User’s Guide.
 - Check the boxes to **Include Gutter** on the roof returns.
- 4 Specify the **Overhang Length**, which is the horizontal distance from the baseline to the eave. See “The Baseline” on page 363.
 - 5 Check **Lower wall type if split by butting roof** to specify the desired wall type for the portion of the selected wall located beneath an adjacent, abutting roof plane, should one be present. The upper portion is defined on the Wall Types tab.

Foundation Tab

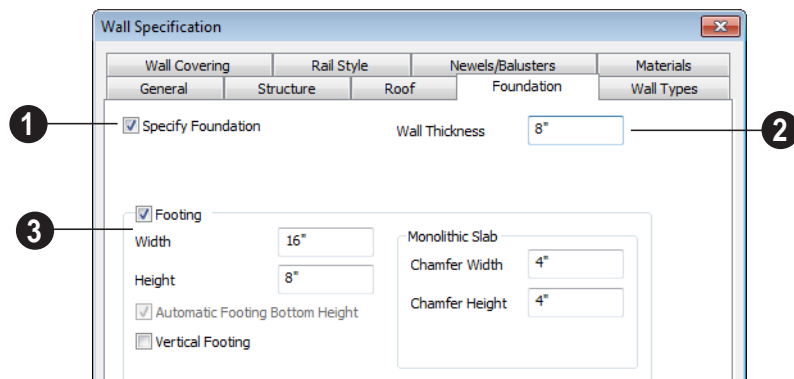

1 Check **Specify Foundation** to turn the selected wall into a foundation wall and enable the settings on this tab. This box is checked by default for automatically generated foundation walls as well as walls drawn with the **Foundation Wall**  tool, and produces a footing beneath the wall.

2 The **Thickness** of the selected wall displays and can be changed here.

3 Check **Footing** to assign a concrete footing to the selected wall(s) and enable the settings below.

- Specify the **Width** and **Height** of the footing below the selected foundation wall(s). The **Height** value will be unavailable if the bottom height of the footing

has been edited. See “Stepped Foundations” on page 340.

- Check **Automatic Footing Bottom Height** to restore the default height of the selected wall’s footing. Only available when the footing bottom height has been edited.
- Check **Vertical Footing** to generate footings that run up and down along any steps in the foundation wall’s bottom height.

Specify how **Monolithic Slab** footings generate.

- Specify the **Chamfer Width** and **Height**, which define the angled corners where the footing meets the underside of the slab.

Wall Types Tab

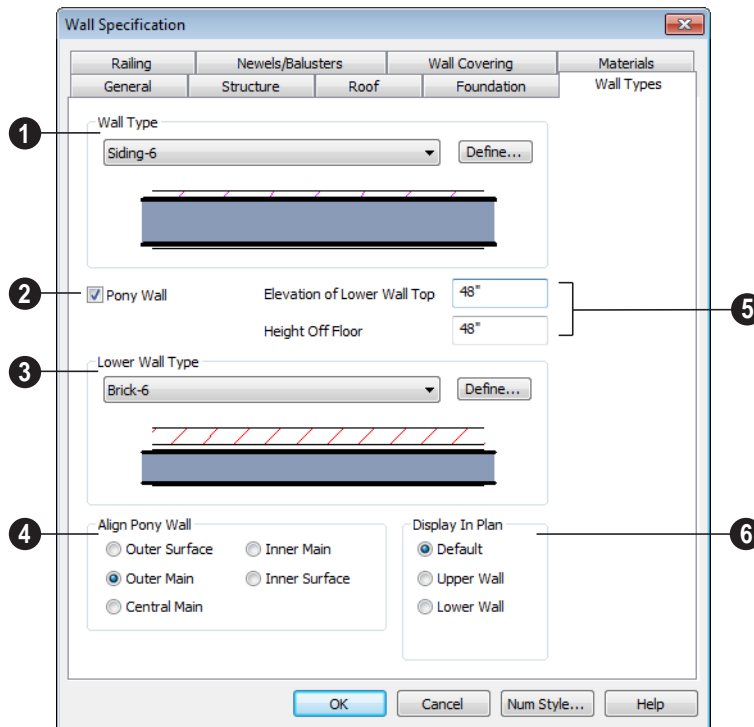

- 1 Choose the selected wall's **Wall Type** from the drop-down list of all currently available types. A preview of the selected wall type displays below the drop-down list.
- 2 Check **Pony Wall** to specify the selected wall as a pony wall having different wall types on its upper and lower portions. See "Pony Walls" on page 184.

If the selected wall is a Foundation Wall, its initial wall type will become the Lower Wall

Type. For all other walls, the initial wall type will be the upper Wall Type.

- 3 Specify the **Lower Wall Type**: the wall type of the lower portion of the pony wall. A preview of the selected wall type displays below the drop-down list.
 - Click the **Define** button to open the **Wall Type Definitions** dialog.
- 4 **Align pony wall** - Specify how the layers of the selected wall's Upper and Lower portions align.
 - **No change** is used by default when multiple pony walls with different alignment settings are selected. Choose this to leave

the alignment as it was when the dialog was opened.

- Select **Outer surface** to align wall types at their outer surfaces.
- Select **Outer main** to align wall types at the exterior edge of their main layers.
- Select **Central main** to align the centers of the main layers of both wall types.
- Select **Inner main** to align the wall types at the interior side of their main layers.
- Select **Inner surface** to align wall types at their interior surfaces.

- 5 Specify the height of the division between the upper and lower walls.

These two settings are dynamic: if one is changed, the other will update accordingly.

- Specify the **Elevation of Lower Wall Top**, which is the division between the upper and lower walls. If the top of the lower pony wall is stepped or raked, this value will be “No Change”. This value is measured from 0” (mm) - the default floor

height for Floor 1. See “Floor Defaults Dialog” on page 316.

- Specify the **Height Off Floor** of the division between the upper and lower walls. This value is measured from the floor height of the room(s) defined by the selected wall. If the wall defines rooms with different floor heights, “No change” will display.

- 6 Specify which part of the pony wall you would like to **Display in Plan** view.

- Select **Default** to display the portion of the pony wall specified in the **Pony Wall Defaults** dialog. See “Wall, Railing, and Fencing Defaults” on page 176.
- Select **Upper Wall** to display the upper portion of this pony wall in floor plan view regardless of the default setting.
- Select **Lower Wall** to display the lower portion of this pony wall in floor plan view regardless of the default setting.
- When walls are group-selected, choose **No Change** to allow each wall in the selection set to maintain its own setting.

Wall Covering Tab

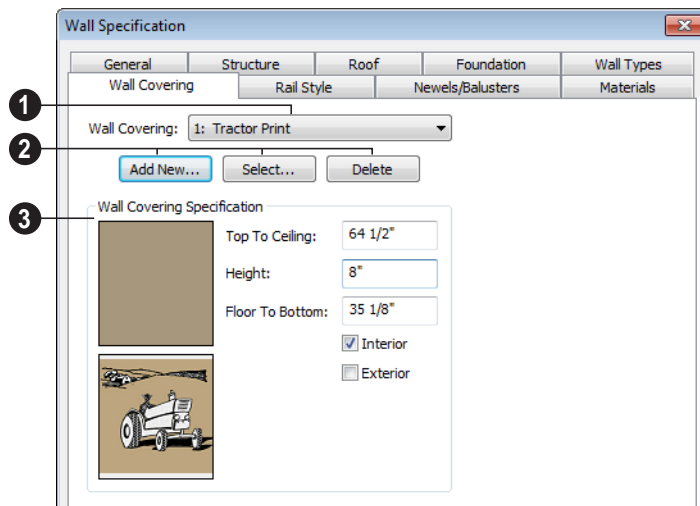

1 All wall covering materials applied to the selected wall are listed here. Select one from the drop-down list to edit it or remove it from the wall.

2 Add, replace or remove the selected wall's wall coverings.

- Click **Add New** to apply a new wall covering to the selected wall. See “Select Library Object Dialog” on page 622.
- Click **Select** to replace the current wall covering with a new one from the library.
- Click **Delete** to remove the current wall covering from the selected wall.

3 Specify the position of the current wall covering. Preview panes of the current wall covering also display here.

- Enter the heights of the current wall covering's **Top To Ceiling** and **Floor To Bottom**. The wall covering's **Height** from its top edge to its bottom edge can also be specified.

- Check **Interior** and/or **Exterior** to apply the wall covering to the inside and/or outside of the selected wall. Interior is checked by default. See “Wall Type Definitions” on page 209.

Rail Style Tab

The settings on the Rail Style tab are only available for Railings. See Rail Style Tab.

Newels/Balusters Tab

The settings on the Newels/Balusters tab are only available for Railings. See Newels/Balusters Tab.

Materials Tab

All walls - including interior walls, railings and fencing - have an “Exterior Wall Surface” and an “Interior Wall Surface”. See “Interior and Exterior Surfaces” on page 210.

The materials specified on the Materials tab affect the appearance of walls and Solid Railings in 3D views but are not calculated in the Materials List. See “Materials Lists” on page 887.

For most railing types, the “Exterior Wall Surface” component only affects the appearance of the floor platform under the railing, and “Interior Wall Surface” component is not used. For fencing, neither material component is used.

Railing and Fencing Specification Dialogs





To open the **Railing** or **Fencing Specification** dialog, select a railing or fencing, or a group of railings or fencing, and click the **Open Object** edit button.

The **Railing** and **Fencing Specification** dialogs are the same as the **Wall Specification** dialog, but have two tabs that apply only to Railings, Deck Railings, and Fencing. See “Wall Specification Dialog” on page 214.

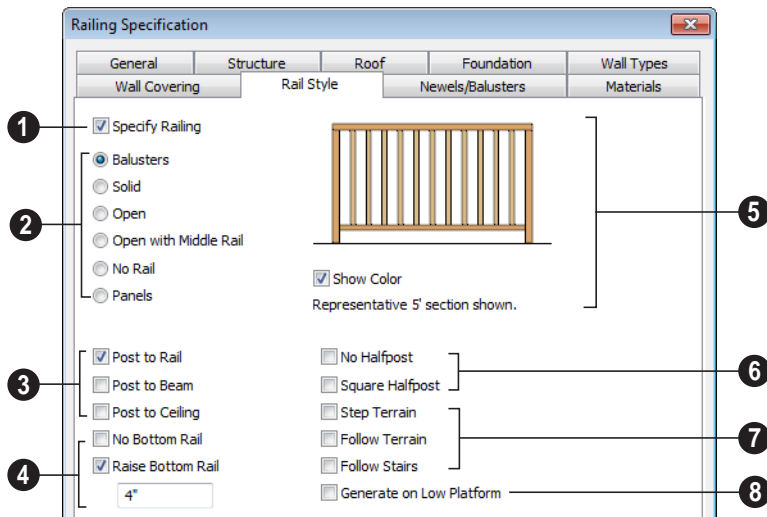
Rail Style Tab



1 Check **Specify Railing** to specify the selected wall as a railing and enable the other options on this tab. Railings can be also drawn directly using the **Railing**  or **Deck Railing**  tools.

2 **Railing Type** - Select the radio button for the desired railing type. A preview of the selected type displays to the left.

- Check **Balusters** to create balusters.

- Check **Solid** to create a solid, wall style railing. The wall is the type defined by the current wall layer definition.
- Check **Open** to create a railing with only a top rail.
- Check **Middle Rail** to create a railing with a top and a middle rail.
- Check **No Rail** to eliminate rails, leaving only pillars or posts (and overhead beam, if selected).
- Check **Panels** to create a solid panel. You can specify the panel style on the Newels/Balusters tab.

3 Newel Posts -

- Check **Post to Rail** to create newel posts from floor to rail height. This option is selected by default.
- Check **Post to Overhead Beam** to create newel posts from floor to an overhead beam placed just under the ceiling height. The beam's width is based on the Thickness of the selected railing wall.
- Check **Post to Ceiling** to extend the newel posts to the ceiling.

4 The **Bottom Rail** options control the placement of the bottom rail, or shoe. If neither box is checked, the bottom rail is placed at floor platform level. Not available for railings specified as Solid or No Rail.

- Uncheck **Include Bottom Rail** to eliminate the bottom rail and extend the balusters to the floor. Not available for Panel railings.
- Check **Raise Bottom Rail**, then specify the bottom rail's height off the floor platform in the text field below.

- 5 A preview of the railing displays here and updates as options are changed.
- Uncheck **Show Color** to display the preview as a line drawing rather than in color.
- 6 Choose a **Halfpost** option for the desired halfpost placement and shape.
- Check **No Halfpost** to prevent a half-width post from being placed when a railing intersects a wall.
- Check **Square Halfpost** to use a square halfpost where a railing intersect with a wall. Not available if No Halfpost is checked.
- 7 Specify whether the selected railing follows the slope of terrain or that of stairs. These options only apply when railing or fencing is drawn outside of a building on top of a defined terrain, or when the railing is drawn at the same location as a staircase.
- Check **Step Terrain** to have the railing or fencing follow the terrain in horizontal steps between each newel.
- Check **Follow Terrain** to have the railing or fencing follow the terrain smoothly.
- Check **Follow Stairs** to have the railing or fencing follow the rise of stairs drawn in the same location. See "Railing Panels" on page 418.
- 8 Check **Generate on Low Platform** to display the selected railing on the lower floor platform when the railing defines two room areas with different floor heights. See "Aligning Railing on Different Platforms" on page 203.

Newels/Balusters Tab

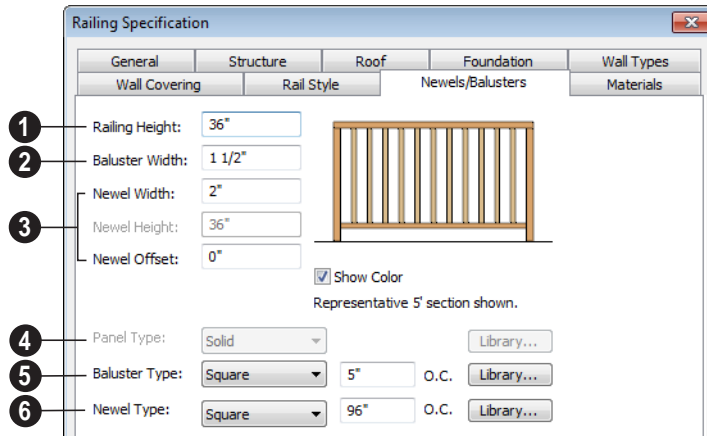

1 Railing Height - Specify the railing height. For interior railings, this is measured from the height of the floor finish. See “Floor and Ceiling Platform Definitions” on page 322.

2 Baluster Width - Specify the width or diameter of each baluster at its widest point. For a Panel railing, this is the panel’s thickness and can be no larger than the railing’s total thickness, shown on the General tab.

3 Specify the characteristics of the selected railing’s newels.

- Specify the **Newel Width**. For a library newel, this is its width or diameter at its widest point.
- Specify the **Newel Height**, which is the height from the ground to the top of the newel. Not available if Post to Rail, Post to Overhead Beam or Post to Ceiling is selected on the Rail Style tab.
- Specify the **Newel Offset**, which is the amount each newel is offset from the cen-

ter of the railing. Use this when creating a fence with the newels to one side of the fence boards.

4 Panel Type is only available when the railing type has been specified as Panels on the Rail Style tab. Select “Solid”, “Framed”, or “Library” to select a symbol to be used as a railing panel.

5 Baluster Type - Only available when the railing type is “Balusters.” Select square, round, or Library balusters and specify their on-center (**O.C.**) spacing.

6 Newel Type - Select square, round, or Library newels and specify their on-center (**O.C.**) spacing.

Note: Selecting Library from the Panel, Baluster or Newel Type drop-down list is the same as clicking the Library button to the immediate right and allows you to select a symbol from the library. See “Select Library Object Dialog” on page 622.

Wall Hatch Specification Dialog



To open the **Wall Hatch Specification** dialog, select a Wall Hatch and click the **Open Object** edit button. See “Hatch Wall” on page 188.

The settings in the **Wall Hatch Specification** dialog are found on the Fill Style tabs of the specification dialogs for many different objects. See “Fill Style Tab” on page 792.

Rooms

When walls or railings create an enclosed area, a “room” is created. You can select rooms defined in this manner like other objects in Home Designer Pro.

Rooms are assigned a Room Type. Each Room Type has predefined characteristics. For example, a room defined as Porch is assigned certain attributes that are different than a Kitchen.

Floor and ceiling heights, baseboard, chair-rail, and crown moldings and materials can be defined room-by-room or for the entire floor.

Chapter Contents

- Floor and Room Defaults
- Room Definition
- Selecting Rooms
- Displaying Rooms
- Editing Rooms
- Room Types
- Room Labels
- Decks
- Floor & Ceiling Heights
- Special Ceilings
- Room Specification Dialog

Floor and Room Defaults



Select **Edit > Default Settings** to open the **Default Settings** dialog where you can access several defaults dialogs which directly affect rooms.

Floor Defaults

Default values for rooms are specified in the **Floor Defaults** dialog for the current floor. This dialog also controls important information that the program uses to create 3D models - particularly floor and ceiling heights and materials. Moldings can also be specified in the **Floor Defaults** dialog.

The default **Floor** and **Ceiling Structure** and **Finish** definitions in the **Floor Defaults** dialog are drawn from the **Normal Room Defaults**. See “Floor and Ceiling Platforms” on page 321.

Only the defaults for the first floor of a building can be set ahead of time. The program uses the setting from the first floor to create subsequent floors. Once a new floor is built, its floor defaults can be changed. See “Floor Defaults Dialog” on page 316.

Room Defaults

Additional structural and material defaults for several categories of Room Types can also be specified:

- Normal Rooms
- Kitchens/Baths/Utility Rooms

- Decks
- Garage/Porches/Slabs

These Room Defaults dialogs are accessed by expanding the “Rooms” category in the **Default Settings** dialog. Select a room type and click the **Edit** button to open the defaults dialog for that room type. See “Room Types” on page 234.

These dialogs allow you to specify the floor and ceiling structures and finishes for different Room Types. See “Structure Tab” on page 245.

Room Label Defaults

The **Room Label Defaults** dialog allows you to specify the initial appearance of room labels. This dialog is also accessed by expanding the “Rooms” category in the **Default Settings** dialog. See “Room Labels” on page 236.

The options on most tabs of the **Room Label Defaults** dialog are similar to those in the **Text Specification** dialog.

Any text added to the **Room Label Defaults** dialog displays in all subsequently created room labels, after the Room Name. Changes made to default settings do not alter existing room labels. To update existing labels so that they reflect changes made to the defaults, delete and replace them. See “Editing Room Labels” on page 237.

Room Definition

A room is a totally enclosed area defined by any combination of joined walls or railings, visible or invisible. To be recognized as a room by Home Designer Pro, a room must have an unbroken perimeter.

Unless otherwise specified, rooms generate floor and ceiling platforms automatically. Most rooms are also automatically covered by the roof when one is built. There are exceptions to this, such as rooms defined as Decks. See “Room Types” on page 234.

If a room is drawn within a larger structure and none of its walls connect to the exterior walls, either directly or indirectly by connecting to walls that do, it is referred to as an “island” room. The program will connect such a room to the larger structure with an Invisible Wall. See “Invisible Walls” on page 187.

Room definition disappears if part or all of a surrounding wall is deleted. It is a good idea to finalize the position of walls before defining rooms with names and attributes such as floor height and ceiling height.

Subdividing Rooms

When a room area is first defined, it inherits its characteristics from the **Floor Defaults** dialog for that floor. If the room is then specified as a particular type, it may inherit properties from the **Room Defaults** dialog associated with its type.

If a new room is created by subdividing a larger room, it inherits its characteristics from that larger room - including any non-default settings.

Selecting Rooms

Room definition is established when a room is completely enclosed by walls. You can confirm that a room has room definition by using the **Select Objects**  tool to select it. When a fully-enclosed room is selected, the room highlights.



The room at left is selected

Note: The selection color can be specified in the Preferences dialog. See “Colors Panel” on page 63.

The Exterior Room

You can also select the exterior of a model. This allows you to control the building’s exterior wall coverings and materials using the **Room Specification** dialog.

Click just outside an exterior wall using the

Select Objects  tool to select the Exterior Room. When it is selected, a highlighted band around the plan’s exterior displays. This band represents the selection area for the Exterior Room.

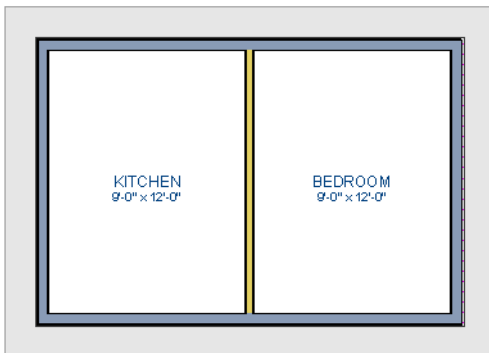

The Exterior Room is selected

In camera views and overviews, the Exterior Room can be selected by clicking on the exterior surface of an exterior wall using the

Select Objects  tool, provided that **Select Room Before Wall** in 3D is selected in the **Preferences** dialog. See “Architectural Panel” on page 73.

In 3D Views

Click on the floor of a room or on a wall surface inside the room in a 3D view using

the **Select Objects**  tool. If you select another object instead of the room, click

Select Next Object  edit button or press the Tab key until the room is selected. The Status Bar indicates which object is currently selected.

The Exterior Room can also be in 3D views selected by clicking once on the exterior surface of an exterior wall using the **Select**

Objects  tool, provided that **Select Room Before Wall** in 3D is selected in the **Preferences** dialog. See “Architectural Panel” on page 73.

Note: If the wall height of the Exterior Room is adjusted in a 3D view, the default Floor or Ceiling Height of the entire floor is changed. See “Floor and Room Defaults” on page 230.

Displaying Rooms

Unlike most things in Home Designer Pro, a room is not an individual object. Rather, a room is defined by the walls that enclose it.

In Floor Plan View

Rooms typically display a transparent fill in floor plan view. You can, however, specify a solid color or fill pattern for all the rooms on an entire floor in the **Floor Defaults** dialog,

or for individual rooms in the **Room Specification** dialog. See “Fill Style Tab” on page 250.

In order for room fill styles to display, the “Rooms” layer must be turned on. See “Displaying Objects” on page 102.

Room labels that include the room’s name as well as its size and other information can be set to display in floor plan view. See “Room Labels” on page 236.

In 3D Views

Rooms can be viewed in 3D views created by any of the 3D view tools. The **Dollhouse View** tools can be used to see all rooms on the current floor without their ceilings. See “Creating Overviews” on page 674.

In the Materials List

The contents of a room, including furnishings and floor and ceiling materials can be calculated using the **Calculate From Room** tool. See “Calculate From Room” on page 888.

Editing Rooms

Once a room is defined by walls or railings, its structure and appearance can be edited using the edit buttons or the **Room Specification** dialog.

In 3D Views

The floor and ceiling heights for floors, rooms, and individual walls can be edited using edit handles in 3D views. Lowered ceilings cannot be edited in 3D. See “3D Views” on page 663.

The default floor and ceiling heights for an entire model can be edited by selecting the Exterior Room. See “The Exterior Room” on page 232.

To change default ceiling heights in 3D

1. Create a 3D or Cross Section/Elevation view of the exterior of your plan.
2. Click on the exterior surface of a wall to select the Exterior Room. The Status Bar

indicates when the exterior room is selected. See “The Exterior Room” on page 232.

3. Click and drag the edit handle on the top wall edge to adjust the default ceiling height, or the edit handle on the bottom edge to adjust the default floor height. Temporary dimensions display.

Note: Any rooms that do not update when the default floor or ceiling height is changed are not using the default values. To use the default values for a specific room, check Default for any of the room height values in its specification dialog. See “General Tab” on page 244.

To adjust room heights in 3D

1. Create a 3D or Cross Section/Elevation view of your plan.
2. Click on the surface of a wall that faces the room to select it. When the room is selected in 3D:

- The room highlights.
 - The Status Bar says “Room”. See “The Status Bar” on page 31.
 - Two edit handles display on the top and bottom edges of the highlighted wall.
3. Click and drag the edit handle on the top wall edge to adjust the room ceiling height, or the handle on the bottom edge to adjust its floor height. Temporary dimensions display.
 4. As you drag a handle, notice that all walls defining that room are affected.

To adjust the height of a wall in 3D

1. Create a 3D or Cross Section/Elevation view of your plan.
2. Click on a surface of the wall. By default, the room will be selected. You can change this behavior in the **Preferences** dialog. See “Architectural Panel” on page 73.
3. Click the **Select Next Object**  edit button to select the wall. The Status Bar says “Wall.” See “The Status Bar” on page 31.

4. Click and drag the edit handles. Temporary dimensions display in elevation views. See “Editing Closed-Polyline Based Objects” on page 138.

Room materials such as floor, ceiling, and wall materials can be changed in 3D views using the **Material Painter** . See “The Material Painter” on page 632.

In the Specification Dialog

 Floor and ceiling heights, floor platform structure, moldings, wall coverings, and materials can all be specified in the **Room Specification** dialog. See “Room Specification Dialog” on page 244.

Using the Edit Tools

A selected room can be edited using the edit toolbar. See “The Edit Toolbar” on page 29.

- Click the **Calculate Materials for Room**  edit button to create a materials list of the contents of the selected room, not including walls. See “Calculate From Room” on page 888.

Room Types

When a room is first created by enclosing an area with walls, it is assigned a generic room type of “Unspecified.”

Once your floor plan is laid out, each room should be assigned a **Room Type** in the **Room Specification** dialog. See “General Tab” on page 244. The Room Type applies appropriate structural and display properties to the room.

When you assign a Room Type, a label showing the room’s Type displays in floor plan view.

You can edit the text of a room label in floor plan view, but the type of room originally assigned remains until it is changed in the **Room Specification** dialog. See “Editing Room Labels” on page 237.

Available Room Types

There are three categories of room types: Interior, Exterior and Hybrid.

Interior - Living, Dining, Family, Kitchen, Nook, Bath, Master Bath, Master Bedrm, Bedroom, Study, Office, Entry, Hall, Closet, Dressing, Storage, Laundry, Utility and Unspecified.

Exterior - Court, Deck, Balcony.

Hybrid - Open Below, Garage, Slab, Porch, Attic.

Effects of Room Types

The program applies specific structural and display properties to rooms depending on the assigned Room Type.

Living Area

- All interior type rooms are included in Living Area calculations by default; exterior and hybrid rooms are not.

Ceilings and Roofs

- Interior rooms have a ceiling and roof above them unless specified otherwise.
- Exterior rooms are assumed to be open to the outside and do not generate a roof above them, or room moldings.
- Attic rooms are ignored by the program's automatic roof generator.
- Garage, Slabs, and Porches are treated like exterior rooms in all cases except that they generate a ceiling and a roof above them.
- A room's default ceiling structure and finish definitions are determined by its Room Type. See "Room Defaults" on page 230.



Floors and Foundations

- Open Below is a unique type of interior room. It has no floor platform and can be used for defining stairwell openings.
- Exterior walls of rooms default to create the foundation type specified in the **Foundation Defaults** dialog.
- Walls that define the garage have a foundation under them defined by the **Foundation Defaults** dialog with a concrete slab at the top of stem wall or grade beam.
- The floor in Garage and Slab rooms display in 3D on Floor 0, not the first floor. See "Garages" on page 338.
- A room's default floor structure and finish definitions are determined by its Room Type. See "Room Defaults" on page 230.
- Defining a room as Slab causes the floor platform thickness to equal the slab thickness value in the **Foundation Defaults** dialog.
- Courts, decks and balconies do not generate foundations.

Doors and Windows

- A window placed in a wall between an exterior room and an interior room always faces out toward the exterior.
- Windows placed between interior rooms generate a warning message.
- Door placed between interior and exterior type rooms display threshold lines.
- Interior doors do not display thresholds.
- Open Below rooms are treated as interior rooms for window and door placement.

Electrical

- The **Auto Place Outlets**  tool adds outlets automatically to all interior rooms except bathrooms. Only one outlet over each sink is added for a bathroom.
- The **Auto Place Outlets**  tool places fewer outlets in hybrid rooms.
- The **Auto Place Outlets**  tool does not place outlets in exterior type rooms, Porches or Open Below rooms.
- Any outlet manually placed in an exterior room automatically becomes a waterproof outlet designed for exterior use.

Trim and Molding

- Moldings are not automatically drawn in exterior or hybrid rooms.
- Baseboards and chair rails are not initially drawn in Open Below rooms, but crown molding, if present, is.

Plan Check

- **Plan Check**  uses the room type and its characteristics for basic plan checking. For example, a closet does not need a smoke detector but a bedroom does. See “Plan Check” on page 801.

Room Labels

A label can display in floor plan view for any area defined as a room. There are two parts to each room label:

- The Room Name, which is similar to a **Text**  object and can be selected and edited. See “The Text Tools” on page 746.
- The room area, which is not a standard text entry and cannot be directly edited.

You can assign a custom Room Name, move a room label or even delete it without affecting the Room Type. See “Room Types” on page 234.



Room labels can move or even disappear when room entries are revalidated.

Room Label Defaults



The initial settings that control the size, font, color and other aspects of room label appearance are controlled in the

Room Label Defaults dialog. See “Room Label Defaults” on page 230.

Custom Room Labels

The Room Names that display in room labels are often based on the Room Types assigned in the **Room Specification** dialog. You can, however create a custom name for a selected room, also in the **Room Specification** dialog. See “General Tab” on page 244.

Before creating a custom Room Name, assign the Room Type most similar to the room’s actual use. For example, if you wish to name a room “Guest Room”, begin by specifying it as a “Bedroom” since these rooms have similar uses.

When a Room Name is based on its Room Type, the name in the label will be in all capital letters. When a custom Room Name is used, capitalization is user-defined.

If you wish to further customize a room's label by adding text, uncheck **Show Room Label** in the **Room Specification** dialog and create your own label using a Text object. See "The Text Tools" on page 746.

Displaying Room Labels

The display of room labels is controlled in the **Layer Display Options** dialog. Room labels are placed on the "Rooms, Labels" layer and use the Text Style assigned to that layer. See "Layer Display Options Dialog" on page 104.

You can specify how the area of rooms is calculated by the program by turning on the display of one or more of these layers:

- **Rooms, Standard Area** is measured from the center of interior walls to either the outside surface of exterior walls or exterior wall framing, depending on the **Living Area to** setting in the **Floor Defaults** dialog. It is rounded to the nearest square foot or mm and does not include the area within bay, box and bow windows. See "General Tab" on page 316.
- **Rooms, Interior Area** is measured from the inner surfaces of all the room's walls. Its format is set on the Dimension Format tab of the **Room Label Defaults** dialog for the current floor. See "Room Label Defaults" on page 230.
- **Rooms, Interior Dimensions** is also measured from the inner surfaces of the room walls. Its format is set in the **Floor Defaults** dialog for the current floor.

The display of room labels can also be controlled on a room by room basis in the **Room Specification** dialog. See "General Tab" on page 244.

Editing Room Labels

Room labels are similar to simple **Text**  objects and can be changed, moved and resized much like any other text object. You can also modify a room label's Text Style and other attributes in the **Room Label Specification** dialog.

The text of a room label cannot be modified in its specification dialog, however: it must be specified in the **Room Specification** dialog. See "General Tab" on page 244.

If you delete a room label, the Room Type and Room Name remain unchanged in the **Room Specification** dialog. To restore the label, check the **Show Room Label** check box on the General tab of that dialog.

Room Area

Unlike the rest of a room label, the room area and dimensions are not standard text entries and cannot be edited or changed. The room area moves, resizes and rotates with the rest of the room label, but you can turn the area and dimensions on or off separately in the **Layer Display Options** dialog. See "Displaying Rooms" on page 232.

The **Interior Area** room area calculation includes the areas within bay, box or bow windows, while the Standard Area and Interior Dimensions calculations do not.

Living Area

The **Living Area** label displays the area of the floor platform for living areas in a plan. It is found near the bottom center of the plan as soon as a room area is defined by walls and/or railing. The area is recalculated every time

you add, delete, or move walls, or **Rebuild Walls/Floors/Ceilings** .

The Living Area displays for an individual building if half or more of that building's area is living area. For example, a living area label would not display for a detached garage that contains a bathroom or small shop.

You can choose not to display this label by clearing the **Show “Living Area”** check box in the **Plan Defaults** dialog or by turning off the display of the Room Labels layer in the **Layer Display Options** dialog.

The Living Area label can be moved or deleted. To restore a deleted Living Area label, select **Tools> Checks> Plan**

Check . You can click the **Done** button immediately, without actually completing Plan Check. See “Plan Check” on page 801.

Living Area vs. Footprint

The Living Area should not be mistaken for the footprint of the house. Only true livable areas are included in the Living Area calculation. By default, exterior and hybrid room types such as Garage, Deck, and Porch are not included. Neither is any room labeled Open Below or Attic. See “Available Room Types” on page 235.

Regardless of its room type, you can specify whether a room is included in the Living Area calculation in the **Room Specification** dialog. See “General Tab” on page 244.

Living Area is measured from either the outside surface or the outer surface of the Main Layer of exterior walls. When walls separate the living area from exterior or hybrid room types, it is measured to the wall center line. See “Wall Type Definitions” on page 209.

Decks

A Deck room is an exterior-type room that uses deck planking and framing to create a floor platform rather than using a floor finish that spans the entire room area. See “Floor and Ceiling Platform Definitions” on page 322.

The default settings for deck planking and framing are set in the **Deck Room Defaults** dialog. The defaults for deck post footings are set in the **Framing Defaults** dialog. See “Room Defaults” on page 230 and “Posts/Beams Tab” on page 449.

To draw a deck, select **Build> Deck> Deck Railing** , then click and drag to draw a railing.

- To create a deck without a railing, use one of the **Deck Edge** tools. See “The Deck Tools” on page 182.
- You can also create a regular, polygon-shaped deck using the **Polygon Shaped Deck**  tool. See “Polygon Shaped Deck” on page 182.

A room does not have to be defined by Deck Railing to be specified as a “Deck.” See “Room Types” on page 234. You can also define a room as a “Deck” in the **Room Specification** dialog. See “General Tab” on page 244.

By default, decks do not have roofs. If you want a roof over a deck, check **Roof Over This Room** in the **Room Specification** dialog. See “Structure Tab” on page 245.

To give the roof a visible means of support, you can select the **Post to Beam** option in the **Wall Specification** dialog. See “Rail Style Tab” on page 224.

Openings in deck railings can be created using **Doorways** . See “Openings in Railings” on page 264.

Deck Framing and Planking

When a Deck room is created, the floor platform is modeled using joists, beams, posts, and planking as specified in the **Deck Room Defaults** dialog. See “Structure Tab” on page 245 and “Deck Tab” on page 248.

- If a floor is present below the one that the Deck room is created on, the framing will be created there. If needed, beams may be generated with posts beneath them, if specified. When terrain is present, the posts will have footings, again, if specified.
- If a floor is not present below the Deck, framing will be generated on the same floor as the room. Beams may be created but posts will not.
- Deck framing and planking are placed on the “Framing, Deck Framing” and “Fram-

ing, Deck Planking” layers, which are often turned off in floor plan view. See “Layer Display Options Dialog” on page 104.

If standard floor framing is present when a room is specified as a Deck, that framing is deleted and replaced with deck framing.

If changes are later made to the settings on the Deck tab of the **Room Specification** dialog, the deck framing and planking will be automatically rebuilt in response. To prevent this from happening, uncheck **Automatic Deck Framing**.

Once created, the individual planking and framing objects generated for a Deck room can be selected and edited like other framing objects, provided that **Automatic Deck Framing** is turned off. See “Editing Framing” on page 460.

To rebuild a deck’s framing and remove any changes you may have made to individual deck framing or planks, select the Deck room and click the **Build Deck Framing**  edit button.

If you delete a Deck room, its deck framing and planking will be automatically deleted, as well. To prevent this from happening, check **Keep Deck Framing After Deck Room is Deleted**. See “Deck Tab” on page 248.

Floor & Ceiling Heights

Default floor and ceiling heights are defined in the **Floor Defaults** dialog for each floor, including the foundation. Use the **Floor**

Defaults dialog to change these values on a floor-by-floor basis. See “Floor and Room Defaults” on page 230.

Use the **Room Specification** dialog to set floor heights on a room-by-room basis. See “Room Specification Dialog” on page 244.

Different rooms on the same floor can have unique floor and ceiling heights, allowing you to create:

- Split levels and bi-levels
- Sunken living rooms and garages
- Cathedral, vaulted, and coffered ceilings.

In 3D views, you can adjust the default floor and ceiling height for the entire floor, the floor and ceiling height for an individual room, or the top and bottom heights of an individual wall. See “In 3D Views” on page 233.



All floor and ceiling heights are measured relative to zero, which is the default floor height for Floor 1. Unlike other default floor and ceiling heights, the default floor height for Floor 1 cannot be changed, but the floor heights of rooms on Floor 1 can be edited individually.

In order to raise or lower an area’s floor or ceiling height, you must give it a room definition. To create room definition without enclosing an area with solid walls, use

Railings .

Invisible walls and railings will fill in the vertical space between floor platforms of different heights as long as **Generate Between Platforms** is checked in their specification dialog. See “General Tab” on page 214.

Ceiling and floor heights are interrelated. Changing the floor height in one room can affect ceiling heights of the rooms below.

- If a room’s floor is lowered, its ceiling height is increased while the ceiling below that room drops.
- If the floor is raised, the ceiling height decreases while the ceiling below that room is raised.

If the rooms above a particular room have more than one floor height, the room’s ceiling is stepped.

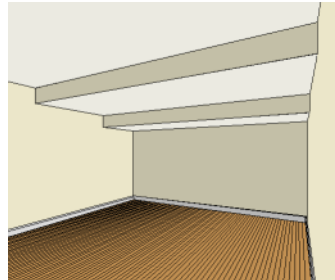

In a situation like this, a Lowered Ceiling can be used to cover “steps” made by different floor heights on the floor above. See “General Tab” on page 244.

Dropped Ceilings

You can create a dropped, or suspended, ceiling by specifying its structure in the **Ceiling Finish** dialog either for a room or the defaults for a floor. See “Floor and Ceiling Platform Definitions” on page 322.

To create a framed dropped ceiling

1. Select a room and click the **Open Object**  edit button.
2. On the Structure tab of the **Room Specification** dialog, click the **Ceiling Finish** button. See “Structure Tab” on page 245.
3. In the **Ceiling Finish** dialog:
 - Check **Frame Lowered Ceiling**.
 - Specify the depth of the **Air Gap**, or the distance between the bottom of the ceiling platform and the top of the lowered ceiling framing.
 - Specify the **Framing Thickness**, which is the depth of the framing layer.

A dropped ceiling composed of a metal grid requires only two layers: one for the plenum and one for the tiles. To achieve this, set the Framing Thickness to 0” (mm).

Split Levels

A split level can be created by raising or lowering the floor and ceiling heights of various areas of the plan.

In the following example, the lowest floor height is 0, the next is 24, and the next is 48 inches. The ceiling height in each room is set at 109 inches. See “Split Levels” on page 325.

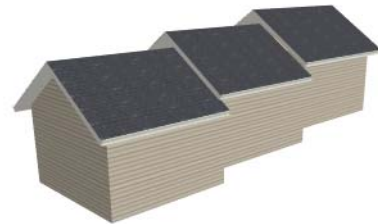

Special Ceilings

By default, the program builds a flat ceiling platform on top the wall plates of a room. More varied and complex ceilings are made using settings in the **Room Specification**

dialog and the **Ceiling Plane**  tool. Ceiling planes are drawn and can be edited much like roof planes. See “Ceiling Planes” on page 379.

Lowered Ceilings

You can define a lowered or dropped ceiling in a room without affecting the top plate height of the walls by specifying the lowered ceiling framing as a layer in the ceiling finish.

In the following illustration, the default ceiling height for the entire first floor is 120", and the room on the right has a ceiling finish lowered to 96".

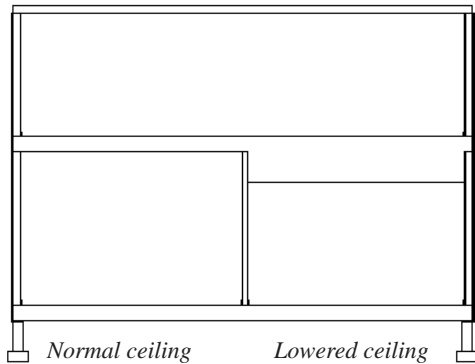

To create a lowered ceiling

1. Select the room in which you would like to specify a lowered ceiling.
2. Click the **Open Object**  edit button to open the **Room Specification** dialog.
3. On the Structure tab, click the **Ceiling Finish** button to open the **Ceiling Finish** dialog. See “Floor/Ceiling Structure Definition Dialog” on page 323.
 - Check **Frame Lowered Ceiling**.

- Specify the **Air Gap**, which is the distance between the bottom of the platform above and the top of the lowered ceiling framing.
 - Specify the **Framing Thickness**, which is the depth of the lowered ceiling joists.
4. When you are finished, click OK to close the **Ceiling Finish Definition** dialog.
 5. On the Structure tab, notice that the preview diagram represents the Finished Ceiling height (F).

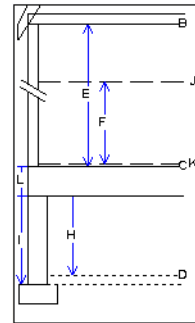

Vaulted and Cathedral Ceilings

A cathedral ceiling has the same pitch as the roof and is created using the underside of the roof above the room. A vaulted ceiling typically has a different pitch from that of the roof and is often framed using scissor trusses. See “Scissors Trusses” on page 478.

To create a cathedral ceiling

1. Build a roof for your plan. See “Roofs” on page 349.
2. Select the room and open the **Room Specification** dialog. See “Room Specification Dialog” on page 244.

3. On the Structure tab, clear the check box for **Ceiling Over This Room**.

By default, cathedrals ceiling use the ceiling material set in the **Room Specification** dialog. If you require a different material on a given roof plane, uncheck **Use Room Ceiling Finish** in the **Roof Plane Specification** dialog. See “Options Tab” on page 374.

To create a vaulted ceiling

1. To create a ceiling pitch different from the roof’s, select **Build> Roof> Ceiling**

Plane  and draw ceiling planes. See “Ceiling Planes” on page 379.

2. Select each ceiling plane and specify its pitch. See “Ceiling Plane Specification Dialog” on page 380.

Tray Ceilings

A tray ceiling is flat in the center and sloped around the perimeter, and is easily created using the underside of roof planes above.

To create an automatic tray ceiling

1. In the **Room Specification** dialog, make sure that **Ceiling Over this Room** is checked, then specify the desired height of the walls as the **Ceiling Height**. See “Structure Tab” on page 245.
2. Make sure that **Auto Rebuild Roofs** is unchecked, then build the roof. See “Build Roof Dialog” on page 355.
3. Change the **Ceiling Height** of the room to the desired height of the flat ceiling surface in its center.

In floor plan view, dashed lines indicate where the ceiling changes from sloped to flat. These lines are located on the “Ceiling Break Lines” layer in the **Layer Display Options** dialog. See “Layer Display Options Dialog” on page 104.

If the roof is rebuilt after the ceiling height is adjusted upward, the new roof will be raised to match the new ceiling height and a tray ceiling will not be created.

In the following example, a hip roof is built on 8’ (2400 mm) ceilings. After the roof is built, the Ceiling Height is raised to 10’ (3000 mm). The resulting ceiling follows the roof pitch for 2’ (600 mm), then becomes a flat ceiling.

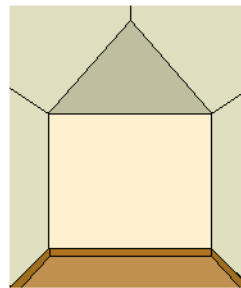

Hip roof with cathedral ceiling over.

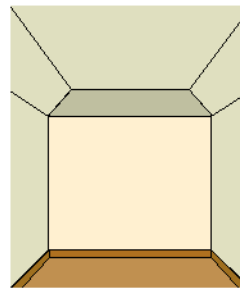

Hip roof, ceiling over, ceiling height raised.

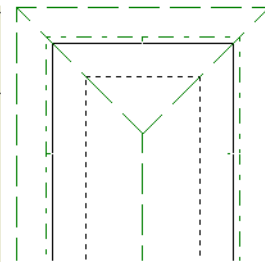

Ceiling Break lines in floor plan view.

Cantilever Undersides

Occasionally, a room will cantilever out past an exterior wall. You can specify the surface material of the underside of a cantilever on the Materials tab of the **Room Specification**

dialog. For no material, select “No Material” from the **Plan Materials** dialog. See “Room Specification Dialog” on page 244.

Other Special Ceilings

Soffits  can be used in various ways to enhance the 3D model. Soffits' ability to follow the slope of the roof offers unlimited possibilities, such as exposed beams or trusses and coffered ceilings. See "Special Applications for Soffits" on page 590.



Framing members and locked roof trusses can also be used for similar purposes.

Room Specification Dialog

 The **Room Specification** dialog controls the structural characteristics and appearance of a selected room. To open the **Room Specification** dialog, select a room and click the **Open Object** edit button. See "Selecting Rooms" on page 231.

Several of the tabs in the **Room Specification** dialog are also found in the **Floor** and **Room Defaults** dialogs. See "Floor and Room Defaults" on page 230.

Some values in this dialog are dynamic. A value with Default checked is referenced from the **Floor Defaults** dialog. To return a value to the default, replace the check mark. See "Dynamic Defaults" on page 57.

The settings in this dialog are similar to those in the **Floor Defaults** dialog, but affect only the selected room. See "Floor Defaults Dialog" on page 316.

General Tab

The General tab is not available in the **Room Defaults** dialog, and only two of the settings

here are active in the **Floor Defaults** dialog. See "Floor and Room Defaults" on page 230.

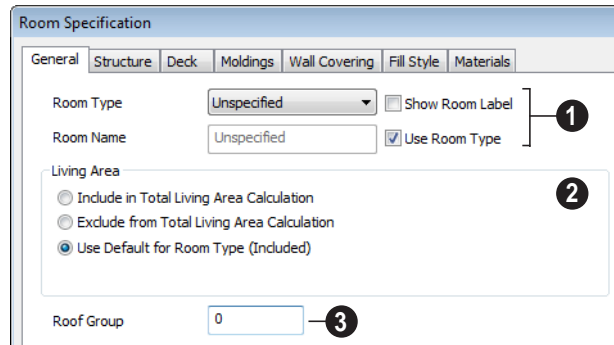

- 1 The settings here control the Room Type and the appearance of the Room Label.
 - Select the **Room Type**. This affects some of the room’s characteristics. Not available when multiple rooms are selected. See “Room Types” on page 234.
 - Check **Show Room Label** to display the room label in floor plan view. This option is unchecked automatically if you select “Unspecified” as the room type. See “Room Labels” on page 236.
 - If you wish to use a custom name in the room label, uncheck **Use Room Type**, then specify the desired **Room Name** in the text field.
- 2 Specify whether the selected room is included in the **Living Area** calculation. See “Living Area” on page 237.

- Select **Include in Total Living Area Calculation** to include the room in the Living Area regardless of its Room Type.
 - Select **Exclude from Total Living Area Calculation** to exclude the room in the Living Area regardless of its Room Type.
 - Select **Use Default for Room Type (Included/Excluded)** to base the selected room’s inclusion in the Living Area on its Room Type.
- 3 Specify the **Roof Group** of the selected room. Change this value to control how the program combines the selected room’s roof system with that of the rest of the building when automatic roofs are built. This value is nearly always left at zero. See “Roof Groups” on page 353.

Structure Tab

The Structure tab is also found in the **Floor** and **Room Defaults** dialogs and features a cross section diagram that shows the relationships between its various heights and platform thicknesses. It is meant to represent the relationships between heights and

thicknesses rather than provide a scaled drawing of the model.

Two floors can be included in the diagram: the floor that the selected room is located on, and the floor below it, if one exists.

What appears in both the diagram and in the settings to its left may be affected by the location where you clicked to select the room. For example:

- If the selected room is located above two rooms with different structural settings, the position of the pointer relative to these two lower rooms determines which of them displays as the floor below.

- If the selected room is located below two rooms with different floor heights, its absolute and relative ceiling height settings will be disabled.

When multiple rooms are selected, only the Floor and Ceiling Structure and Finish can be specified. In some **Room Defaults** dialogs, only the **Floor Structure** and/or **Finish** can be modified. See “Floor and Room Defaults” on page 230.

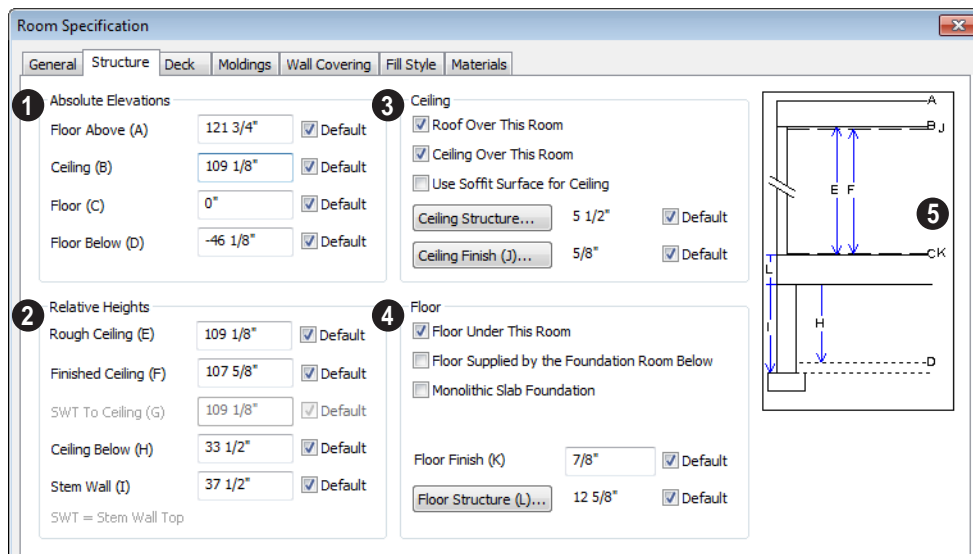

Check the **Default** box beside any height value to restore the default setting. In the **Floor Defaults** dialog, the Floor and Ceiling Structure and Finish defaults are drawn from the **Normal Room Defaults** dialog. See “Dynamic Defaults” on page 57.

1 Absolute Elevations - These height values are measured from the default first floor height of zero. See “Floor & Ceiling Heights” on page 239.

- Specify the **Floor Above** height, which is the floor height of the room or rooms on the floor above the selected room. If multiple floor heights are specified directly above the selected room, this setting will be inactive and “No Change” will display.
- Specify the **Ceiling** height of the selected room. Not available in the **Room** or **Floor Defaults** dialog or if multiple floor heights are specified above the selected room.
- Specify the **Floor** height.

Note: The default floor height for Floor 1 is 0. It can be modified in the Room Specification dialog, but not in the Floor 1 Defaults dialog. See “Floor and Room Defaults” on page 230.

If a room is defined directly beneath the selected room on the floor below, additional settings may be available.

- Specify the **Floor Below** height, which is the floor height of the room directly below where you clicked to select the currently selected room.
- If the selected room is directly above a Garage and there is a foundation present, you can specify the **SWT Below** height, which is the top height of the concrete stem walls around the perimeter of the garage.

2 Relative Heights - These height values are measured from surfaces within the selected room or the room below.

- Specify the **Rough Ceiling** height, as measured from the subfloor surface to the bottom of the ceiling framing. Not available if multiple floor heights are specified directly above the selected room.
- Specify the **Finished Ceiling** height, as measured from the finished floor surface to the finished ceiling surface. Not available if multiple floor heights are specified directly above the selected room.
- Specify the distance from the **Stem Wall Top to Ceiling**. Only available when **Floor for this Room is Supplied by the Foundation ‘Room’ from the Floor Below** has been checked.
- Specify the **Ceiling Below** height, which is the height of the ceiling of the room

below, as measured from that room’s sub-floor to rough ceiling surfaces. Not available when Auto Rebuild Foundation is enabled or if there is no room below the selected room. See “Rebuilding Foundations” on page 336.

- Specify the **Stem Wall** height, which is measured from the bottom of the room’s floor framing to the top of the foundation wall footing and including a treated sill plate, if one is specified. Only available if the selected room or the room below it is defined by foundation walls.
- 3** Specify the characteristics of the room’s **Ceiling**.
- If **Roof Over This Room** is checked, a roof automatically generates over the room. If unchecked, no roof generates.

If this option is unchecked and a roof plane is manually drawn over this room, its structure will be that of an eave rather than a regular roof. See “Roof Tab” on page 451.

- If **Ceiling Over This Room** is checked, the room has a flat ceiling. If unchecked, the ceiling follows the underside of the roof or manually drawn ceiling planes.
- Check **Use Soffit Surface for Ceiling** to frame the roof over the selected room using the framing defaults for fascia rather than for rafters.
- Click the **Ceiling Structure** button to open the **Ceiling Structure Definition** dialog and define the layers of materials that form the ceiling platform. Not available for rooms on Floor 0. See “Floor/Ceiling Structure Definition Dialog” on page 323.

- Click the **Ceiling Finish** button to open the **Ceiling Finish** dialog and define the layers of materials that form the finished ceiling surface. See “Floor/Ceiling Structure Definition Dialog” on page 323.
 - Check the **Default** box to the right of either button to restore the default structure and/or finish.
- 4** Specify the characteristics of the room’s **Floor**.
- When **Floor Under This Room** is checked, the room has a floor platform as specified below.
 - If **Floor Supplied by the Foundation Room Below** is checked, the floor for this room is a slab located on the floor below.
 - If **Monolithic Slab Foundation** is checked, a slab is generated beneath the selected room when a stem wall or pier and grade beam foundation is generated. If unchecked, the room receives a foundation like the rest of the plan. Only available if the selected room is on Floor 1 and does not have a room beneath it.
- Specify the thickness of the **Floor Finish** layer.
 - Click the **Floor Structure** button to open the **Floor Structure Definition** dialog and define the layers of materials that form the floor platform. See “Floor/Ceiling Structure Definition Dialog” on page 323.
 - If the selected room is a Deck, the Floor Structure button will be labeled **Planks, Joists** instead. See “Decks” on page 238.
 - Check the **Default** box to the right of either button to restore the default structure and/or finish.
- 5** A cross section diagram showing the relationship between the various height settings displays here for reference.

Deck Tab

The options on the Deck tab are only available for rooms designated as Decks, and control how deck framing and planking are generated. See “Deck Framing and Planking” on page 239.

The settings on this tab are also found in the **Deck Room Defaults** dialog, but affect the selected Deck room(s) only rather than Decks as they are initially created. See “Room Defaults” on page 230.

1 Check **Automatic Deck Framing** to generate planking and support framing for the deck that updates as changes are made to the deck. See “Decks” on page 238.

- Check **Keep Deck Framing After Deck Room is Deleted** to retain the automatically generated framing and planking when the selected deck room is deleted. When this box is unchecked, the framing is automatically removed if the room is deleted.

2 Specify the appearance of the **Deck Planking**.

- Specify how far the deck planking **Overhangs** the rim joists.
- Specify the **Plank Width** of the deck planking.
- Specify the **Plank Gap Width**, which is the distance between individual planks.
- If you want to enter a **Plank Direction**, remove the checkmark from **Automatic**. Enter the direction as degrees.

4 **Deck Support Joists**
Set joist depth and type in second layer of floor structure.

Joist Width

Joist Spacing

Joist Direction Automatic

5 **Deck Support Beams**

Deck Support Beams

Beam Depth

Beam Width

Beam Spacing

Beam Type:

- Specify the **Number of Border Planks**. These are planks that follow the outside edge of the deck and may not be parallel with the rest of the planking. Border planks generate as long as the length of an inside edge is greater than 0”. They do not generate on curved deck edges.

Note: Planking thickness and joist depth are specified in the Floor Structure Definition dialog. See “Floor and Ceiling Platform Definitions” on page 322.

- Check **No Border Against Walls** to prevent border planking from being generated along any walls defining the deck.
 - Check **Herringbone** to produce a herringbone pattern where the border planks meet.
- 3 Specify whether **Deck Posts And Footings** are generated beneath the selected deck.

The default footing size is set in the Framing Defaults dialog, and the default deck post size is based on the width of the deck beam directly above it. See “Posts/Beams Tab” on page 449.

4 Specify the configuration of the **Deck Support Joists**.

- Enter the **Width** of the joists that support the deck.
- Specify the **Spacing** between joists, as measured from joist center to joist center.
- If you want to specify joist **Direction**, uncheck **Automatic** and enter the direction as degrees. When checked, joists are run in the direction that results in the shortest spans.

5 Specify the configuration of the **Deck Support Beams**.

- Enter the **Depth** and **Width** of the beams that support the deck. The **Width** value also controls the size of automatically generated deck posts.
- Specify the **Spacing** between beams, as measured from beam center to center.
- Select the **Type** of deck joists from the drop-down list. See “Framing Member Types” on page 463.

Moldings Tab

Chair rail, crown and base moldings can be assigned to one or more rooms on the Moldings tab. Moldings are placed around the wall surfaces of a room and continue around the surface of any soffit that is attached to the wall at the molding height.

The settings on the Moldings tab are similar to those found in other specification dialogs

throughout the program. See “Moldings Tab” on page 503.

The settings on this tab are also similar to those found in the **Floor Defaults** dialog, but affect only the selected room instead of all rooms on the current floor.

Wall Covering Tab

The settings on the Wall Covering tab of the **Room Specification** dialog are the same as those on the same tab of the **Wall Specification** dialog. When a wall covering is assigned in the **Room Specification** dialog, it is applied to all walls in the selected room only. See “Wall Covering Tab” on page 223.



Wall coverings can be applied to exterior rooms as well by selecting the exterior room and opening it for specification. See “Selecting Rooms” on page 231 for information about selecting exterior rooms.

Fill Style Tab

The settings on this tab affect the appearance of the room in floor plan view. This tab is also found in the **Floor Defaults** dialog. For more information, see “Fill Style Tab” on page 792.

Materials Tab

The settings on this tab affect the appearance of a selected room’s walls, floor, ceiling and moldings in 3D views. See “Materials Tab” on page 635.

Default molding and ceiling and floor covering materials can be set in the **Floor Defaults** dialogs.

Doors

Home Designer Pro comes with tools for creating a wide variety of interior and exterior doors. In addition, the library offers a large selection of specialty doors and doorways including hinged, sliding, pocket, bifold, and garage doors. Additional name-brand door catalogs are also available for download from our web site, www.HomeDesignerSoftware.com.



Chapter Contents

- Door Defaults
- The Door Tools
- Displaying Doors
- Editing Doors
- Changing Door Swings
- Special Doors
- Door Specification Dialog

Door Defaults

 Default Settings are accessed by selecting **Edit> Default Settings**.

Click the “+” next to **Doors** to show the door sub-headings. Select a subheading and click the **Edit** button to open the defaults dialog associated with your selection:

Door Defaults can also be accessed by double-clicking the **Door Tools**  parent button or the **Hinged Door**  or **Sliding Door**  child button. Double-clicking the other Door Tools child buttons will open the defaults dialog for that particular door type.

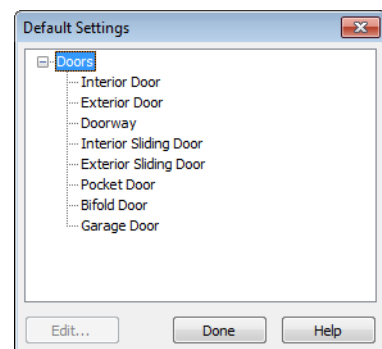

The values in the **Door Defaults** dialog are initial values for interior or exterior doors. Individual doors can be edited after they are created.

The **Door Defaults** dialogs look nearly the same as the **Door Specification** dialog. See “Door Specification Dialog” on page 265. There are only a couple of differences:

- Since default settings are specified here, “Use Default” is not an option for some settings as it is in the **Door Specification** dialog.
- The **Door Type** cannot be changed in the Defaults dialogs.

Dynamic Door Defaults

A variety of door default values are dynamic, including the **Add for Rough Opening** values, **Casing** and **Lintel Specifications**, and **Hardware**. When a dynamic default is changed, existing doors using the default

value are affected. See “Dynamic Defaults” on page 57.

All **Materials** listed under “Doorway” on the Materials tab are also dynamic. Materials assigned to doors and hardware items from the library are listed separately and are dynamically linked to the “Interior Door”, “Exterior Door” and “Fixture Trim” and “Hardware” materials set in the **Material Defaults** dialog rather than the **Cabinet Defaults** dialog. See “Material Defaults Dialog” on page 650.

Door Framing

The default Rough Opening for doors can be defined in the **Door Defaults** dialogs. You can also specify an additional amount to cutout for door openings in concrete garage curbs and foundation walls. See “General Tab” on page 266.

The defaults for trimmers and headers can be specified in the **Build Framing** dialog. See “Framing Defaults” on page 436.

The Door Tools



To place a door, select the type you want from the **Build> Door** submenu.

With a Door Tool active, move your mouse pointer over a wall section. If there is room enough along the wall to fit a 12” (300 mm) wide door, a preview of the door will display. When a preview can be seen, click on a wall to place a door in the wall at that location.

Hinged and Sliding Doors have both Interior and Exterior Door Defaults. If the wall is an exterior wall or one that separates an interior from an exterior room, the program places an

exterior door based on the default settings for exterior doors. If the wall is an interior wall, the program places an interior door based on the default settings for interior doors. This rule applies to doors copied and pasted from one location to another just as it does to newly placed doors. See “Door Defaults” on page 253.

Doors can also be placed in curved walls. See “Options Tab” on page 268.

Once placed, any door may be changed into any other type of door using the **Door**

Specification dialog. See “Door Specification Dialog” on page 265.

Hinged Doors



Select **Build> Door> Hinged Door** and click a wall where you want to place a hinged door. Hinged doors can be placed on interior or exterior walls, and can be set up so that different door styles are placed in each. A hinged door becomes a double door when its width is four feet or greater.

The initial swing direction of a hinged door depends on the location of the mouse pointer relative to the wall when you click. The door will swing towards the side of the wall that you click nearest.

The initial hinge side of a hinged door can be set by clicking to place the door and then holding the mouse button down rather than releasing it. Move the mouse toward the end of the door that you would like the hinges to be on: as the mouse pointer nears either end, the door preview’s hinge side will move to that end. You can also adjust the door’s swing direction in this manner. When the swing direction and hinge side are correct, release the mouse button.

Doorways



Choose **Build> Door> Doorway** and click a wall to place a doorway (an opening without a door). Doorways can be placed on interior or exterior walls, or in railings and fences to provide an opening. You can assign a door from the library to a doorway.

Sliding Doors



Select **Build> Door> Sliding Door** and click a wall where you want to place a sliding door. Sliding doors can be placed on interior or exterior walls and can be set up so that different door styles are placed in each. If placed in an exterior wall, the door is glass; if placed in an interior wall, it is a solid slab.

The initial opening side of a sliding door can be specified by moving the mouse pointer along the wall while the mouse button is still pressed.

The default sliding door dimensions are 5’-0” x 6’-8” with a 12” bottom frame and a 6” frame on the sides and top.

Pocket Doors



Select **Build> Door> Pocket Door** and click a wall where you want to place a pocket door.

As with sliding doors, the initial opening side of a pocket door can be specified by moving the mouse pointer along the wall while the mouse button is still pressed.

The default pocket door dimensions are 2’-6” x 6’-8” high. A pocket door becomes a double pocket door if its width is four feet or greater.

Bifold Doors



Choose **Build> Door> Bifold Door** and click a wall where you want to place a bifold door.

Like a hinged door, the initial opening side of a bifold door depends on the location of the mouse pointer relative to the wall when you

click. The door will open towards the side of the wall that you click nearest.

Similarly, the initial hinge side of a sliding door can be specified by moving the mouse pointer along the wall while the mouse button is still pressed.

The default interior single bifold door is 2'-6" x 6'-8". A bifold door becomes a double bifold if its width is greater than three feet.

Bifold doors always display closed in all 3D views.

Garage Doors



Choose **Build> Door> Garage Door** and click a wall to place a garage door.

The default garage door is 8'-0" x 7'-0" high. A garage door must be at least two feet wide.

In floor plan view, dashed lines show the size and location of the garage door when open.

Garage doors will build into a garage stem wall provided the room is designated as a garage before the door is inserted. See "Room Types" on page 234.

The Doors & Doorways Library



The Doors & Doorways library can be accessed by selecting **Library> Library Browser** and browsing to Home Designer Content> Architectural. This library folder contains a variety of interior

and exterior doors, as well as special entryways and wrapped openings.

Entryways and wrapped openings are examples of Doorways, which are wall openings that do not have doors within them.



To add a door to the Doorway, select a **Door Type** other than "Doorway" from the drop-down list in the **Door Specification** dialog. See "General Tab" on page 266.

You can also select a custom door from the library and place it into a doorway in floor plan view or any 3D view.

To place a library door in a doorway

1. Go to floor plan view or any 3D view.
2. Open the Library Browser.
3. Navigate through the Doors library category until you find the custom door style desired.
4. Select the door in the Library Browser, then click on the doorway to place the selected door within it. If a door already exists, it is replaced.
5. Continue clicking other doorways until all changes have been made.

Displaying Doors

 The display of doors, door labels, opening indicators, headers, and casing is controlled in the **Layer Display Options** dialog. See “Layer Display Options Dialog” on page 104.

Doors can only be placed in walls, so if a wall’s layer is turned off, any doors placed in that wall will not display, either. See “Displaying Walls” on page 192.

If the “Doors” layer is turned off, doors and their casing do not display but openings in the walls where they are located are visible.

In Floor Plan View

When the “Doors” layer is turned on in floor plan view, door symbols represent the width of the opening and indicate its swing. If a door is recessed, the affected wall layers will adjust to accommodate the casing.

Doors in exterior walls and doors that open to exterior type rooms such as a Garage, Porch, or Deck have a threshold line across the opening in floor plan view. See “Room Types” on page 234.

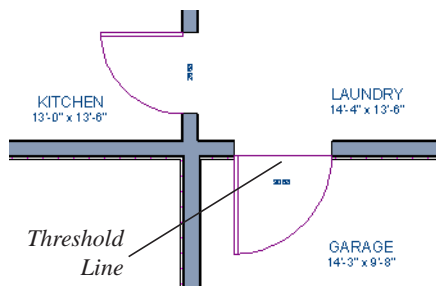



If an exterior door to a Garage room on Floor 1 extends into a Garage stem wall or curb on Floor 0, its location will be indicated on

Floor 0. You can control the display of this concrete cutout in the **Door Specification** dialog. See “Garages” on page 338.

When the “Doors, Headers” layer is turned on in floor plan view, door headers are represented by dashed lines within each door’s opening. These lines do not correspond to actual framing objects and cannot be selected. See “Wall Framing” on page 436.

The vertical casing on the sides of doors will display in floor plan view when the “Casings, Exterior” and “Casings, Interior” layers are turned on. See “Casing Tab” on page 269.

In 3D Views

You can specify whether a selected door is shown open or closed in 3D views by clicking the **Show Door Open in 3D**  and **Show Door Closed in 3D**  edit buttons as well as in the **Door Specification** dialog. See “Options Tab” on page 268.

If a door is set to display open in 3D, the angle of the open door can be changed using the edit handles. See “Using the Mouse” on page 258.

To display opening indicator arrows in Vector Views, turn on the “Opening Indicators” layer in the **Layer Display Options** dialog. See “Vector View” on page 711.

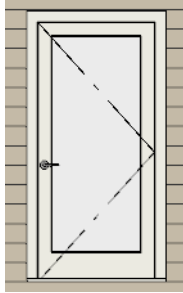

Door with opening indicator

Reverse door opening indicators on the Architectural panel of the **Preferences** dialog. See “Architectural Panel” on page 73.

You can also specify whether door and window glass is opaque or transparent in Vector Views in the **3D View Defaults** dialog. See “Options Tab” on page 669.

Door Labels

Door labels display in floor plan view, centered on the doors they represent, when the “Doors, Labels” layer is turned on. Door labels use the Text Style assigned to this layer, as well. See “Object Labels” on page 884.

Door labels indicate Width and Height. For example:

- In Imperial plans, the automatic label for a 3’-0” wide, 6’-8” high double hung window will read 3068.
- In metric plans, the automatic label for a 900 mm wide, 2100 mm high double hung window will read 900x2100.

Customized labels as well as label position and orientation can also be specified in the **Door Specification** dialog.

Editing Doors

Before a door can be edited, it must be selected. To select a door, click it when the

Select Objects  tool or any of the **Door**

Tools  are active. Doors and/or windows can also be group selected and edited. See “Selecting Objects” on page 124.

Blocked units are made up of individual doors and windows that have been grouped together to act as one object. You can create what is essentially a blocked door unit by assigning a library door to a doorway from the library

Select a blocked unit by clicking on it in any view. To select a door that is a component of a blocked unit, click at the location of the component in question, then click the **Select**

Next Object  edit button. See “Selecting Objects” on page 124.

In the Specification Dialog

 The most precise method of editing a door or group of doors is to use the **Door Specification** dialog. Door type, size, casing, materials, shape, and more can all be specified in this dialog. See “Door Specification Dialog” on page 265.

Using the Mouse

In floor plan view, click either of the two end handles and drag along the wall to change the width. The label showing the size updates as the handles are dragged. Click and drag the

Move handle at the center to move the door along the wall it is placed in. Use the triangular Rotate handle to adjust the door's swing. If the door's label displays, an additional handle is available to move the label.

In 3D views, a selected door has five edit handles: the Move handle at the center and a Resize handle on each edge. Click and drag an edge handle to resize the door.

Using the edit handles, a door resizes according to the currently active **Edit**

Behavior . See "Edit Behaviors" on page 120.

A door or window moved against an intersecting wall temporarily stops when the casing meets the intersecting wall. You can continue to drag and it resumes movement past the intersecting wall.

Using Dimensions







 Like various other objects, doors can be moved using dimensions. See "Moving Objects Using Dimensions" on page 737.

You can specify how doors and windows are located by dimensions in the **Dimension Defaults** dialog. See "Locate Objects Tab" on page 723.

Dimensions can be set to locate the centers, sides, casing, or rough opening of wall openings, or you can choose to not locate openings at all. If you wish, you can move a dimension's extension lines to locate non-default locations on a door after the dimension is drawn. See "Editing Extension Lines" on page 735.

Using the Edit Tools

A selected door or doors can be edited in a variety of ways using the buttons on the edit toolbar. See "The Edit Toolbar" on page 29.

- Click the **Change Opening/Hinge Side**  edit button to change the side of the door that its hinges are on. See "Changing Door Swings" on page 260.
- Click the **Change Swing Side**  edit button to change which direction the selected door swings.
- Click the **Show Door Open in 3D**  or **Show Door Closed in 3D**  edit button to control the selected door's appearance in 3D views. See "In 3D Views" on page 257.
- Click the **Gable Over Door/Window**  to create a gable over the selected door(s) the next time the roof is rebuilt. See "Gable/Roof Lines" on page 382.
- Click the **Components**  edit button to modify or add information related to the selected door in the Materials List. See "Components Dialog" on page 901.

Centering Doors

 The **Center Object** edit button allows you to center a selected door along a wall within a room or relative to a cabinet or window. See "Using Center Object" on page 156.

To center a door along a wall

1. Select a door or combination of windows and doors in floor plan view.

2. Click the **Center Object**  edit button then choose from one of the following options:
 - Click near a wall inside a room to center the door along that wall in that room.
 - Click outside the house (on the exterior room) near an exterior wall to center the door along an exterior wall.

Door Sides

Like walls, all doors have two sides: an interior side and an exterior side. This is the case even for doors placed in interior walls. See “Exterior and Interior Walls” on page 183.

By default, the interior side of the door will face the direction that the door swings to open. If you prefer, you can specify that the interior side face the opposite direction in the **Door Specification** dialog. See “General Tab” on page 266.

You can specify the materials for the two sides separately in the **Door Specification** dialog. See “Materials Tab” on page 277.

You can also specify different casing for the interior and exterior sides of exterior doors -

that is, doors placed in exterior walls or walls defining a Garage or other exterior room type. See “Room Types” on page 234.

Door Casing

Doors typically feature casing, or trim, on both sides of the wall opening.

- Interior doors use the same casing profile on both sides.
- Exterior doors can have different casing profiles on their interior and exterior sides.

The default casing for interior and exterior doors is a basic rectangular stock profile. You can specify a door’s casing profiles in the **Door Specification** dialog, or you can choose to suppress casing altogether. See “Casing Tab” on page 269.

A separate molding profile can be specified for the lintel, or top horizontal molding. See “Lintel Tab” on page 271.

Interior and exterior door casing will display in all views when the “Casings, Exterior” and “Casings, Interior” layers are turned on. In floor plan view, only the vertical side casing will be shown.

Changing Door Swings



Door swing direction and hinge side can be changed using the **Change Opening/Hinge Side** and **Change Swing Side** edit buttons.

Note: If the door is set to draw closed, the swing as it appears in floor plan view has no effect on the 3D view. See “Options Tab” on page 268.

The **Change Opening/Hinge Side**  edit button is available for all doors except double doors and garage doors.

The **Change Swing Side**  edit button is available for all doors except pocket doors.

Hinged Doors

In addition to using the edit buttons, hinged doors' hinge side and swing direction can be changed using the triangular Rotate edit handle.

To adjust the angle of swing:

1. In floor plan view, select the door and grab the triangular handle.
2. Drag to change the amount of swing.

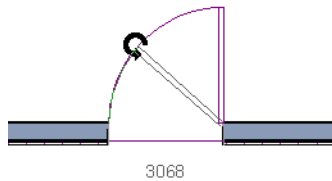

3. Release the mouse.

If you drag near the closed position, the door snaps to a closed position.

To change the swing using edit handles:

1. In floor plan view, select the door and grab the triangular edit handle.

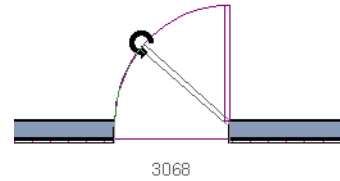

2. Drag the pointer along the path of the new arc to change the hinge side and/or swing direction.

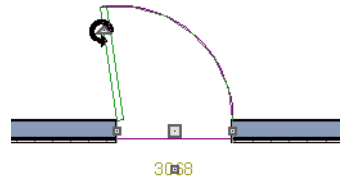

3. Release the mouse.



You can specify a Double Hinged Door to swing from its center in the Door Specification dialog. See "Options Tab" on page 268.

To change the swing using edit buttons:

1. In floor plan view, select the door.
2. To change the hinge side, click the **Change Opening/Hinge Side**  edit button.

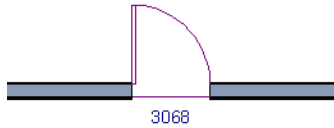
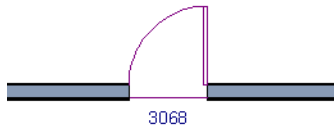

3. To change the swing direction, click the **Change Swing Side**  edit button.

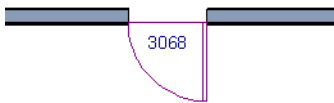
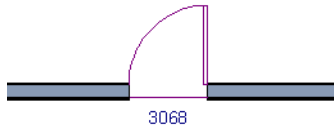

 You can also specify a Hinged Door to swing in both directions in the Door Specification dialog. See "Options Tab" on page 268.

Sliding Doors

To change the side of a sliding door that is fixed, select the sliding door then click the

Change Opening/Hinge Side  edit button.



To flip the fixed and moving sides of the door, click the **Change Swing Side**  edit button.



As with hinged doors, you can also change the Opening/Hinge and Swing sides of a sliding door by clicking and dragging the triangular edit handle.

Pocket Doors

To change the direction of a pocket door, select it and click the **Change Opening/Hinge Side**  edit button.





Note: There must be enough room for the entire door to fit in the opposite wall or the door does not change.

As with hinged doors, you can also change the Opening/Hinge side of a pocket door by clicking and dragging the triangular edit handle.

Bifold Doors

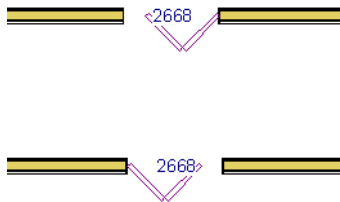
To change the side of a bifold door that is fixed, select it then click the **Change Opening/Hinge Side**  edit button.



To change the hinged side of the door, click the **Change Swing Side**  edit button.

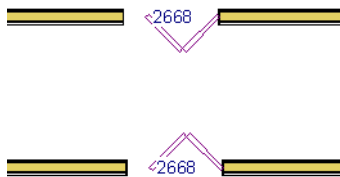

As with hinged doors, you can also change the Opening/Hinge and Swing sides of a bifold door by clicking and dragging the triangular edit handle.

Garage Doors

To change the side of a garage door that it faces, select it and click the **Change Swing Side**  edit button.

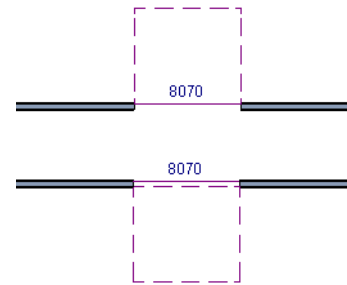

As with other door types, you can also change the Swing side of a bifold door by clicking and dragging the triangular edit handle.

Special Doors

A variety of special doors and doorways can be created in Home Designer Pro.

Wrapped Openings

Wrapped openings of various shapes are available in the **Doors & Doorways Library**.

You can also create a wrapped opening by placing a doorway in the wall and checking **Suppress Casing** in the **Door Specification** dialog. See “Casing Tab” on page 269. If base molding is present, it will wrap around the opening.



Openings in Railings

Use the **Doorway**  tool to open a railing for a stairway or other access.

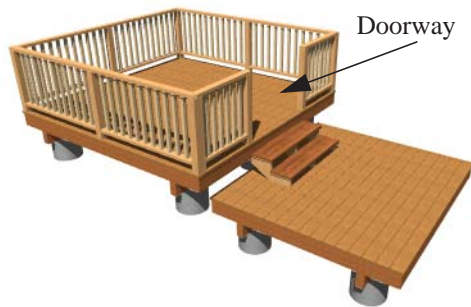

To open a railing across an entire section, resize the doorway's **Width** so that it is greater than the length of the railing in the **Door Specification** dialog. The opening resizes to the maximum width possible for that space. See "General Tab" on page 266.

To add a gate, specify the doorway's **Door Type** as a Door, then choose an appropriate gate as the **Door Style**. A selection of gates is available in the Fences & Railings library folder. See "Placing Library Objects" on page 620.

Transoms Above Doors

Transom windows above doors are created the same as other stacked windows. See "Grouped Windows" on page 284.

Recessed Doors

A door placed in a brick or stone wall is often recessed into the wall's exterior. In the illustration below, the door to the right is recessed, so the brick wraps the opening. The door on the left is not recessed, so the casing is outside the brick.

You can specify a door as recessed in the **Door Specification** dialog. See "Options Tab" on page 268.



Creating a Doorway with a Railing

When a railing is specified as **No Room Def**, it can be positioned within a **Doorway** .



To create a doorway with railing

1. Place a **Doorway**  at the desired location in your plan.

2. Select **Build> Wall> Straight**
Railing , then click and drag to draw a railing parallel to the wall with the doorway.
3. Click on the railing, then use the Resize edit handles to adjust the length of the railing as needed. See “Using the Edit Handles” on page 128.
4. With the railing selected, click the **Open Object**  edit button.
5. On the General tab of the **Railing Specification** dialog, check **No Room Def** and click OK. See “General Tab” on page 214.
6. With the railing still selected, Ctrl + drag it into position within the doorway. See “To move an object freely” on page 153.

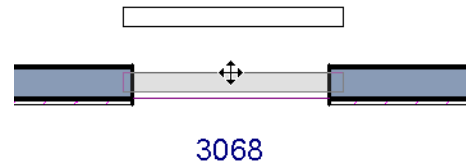



Positioning a railing in a doorway

Placing a Gable Over a Door

 Click the **Gable Over Door/Window** edit button to produce a gable roof over the selected door(s) the next time automatic roofs are built. See “Gable/Roof Lines” on page 382.

You can manually edit or delete this gable line at any time. Your changes take effect when the automatic roofs are rebuilt. This can also be used with group selected doors.

Door Specification Dialog

 To open the **Door Specification** dialog, select a door or a group of doors and click the **Open Object** edit button or double-click on a door using the **Select Objects**  or a **Door**  tool.

If a group of doors is selected, changes made in the **Door Specification** dialog are applied to all the selected doors. If interior doors have different attributes than exterior doors, they must be selected and edited as a separate group.

General Tab

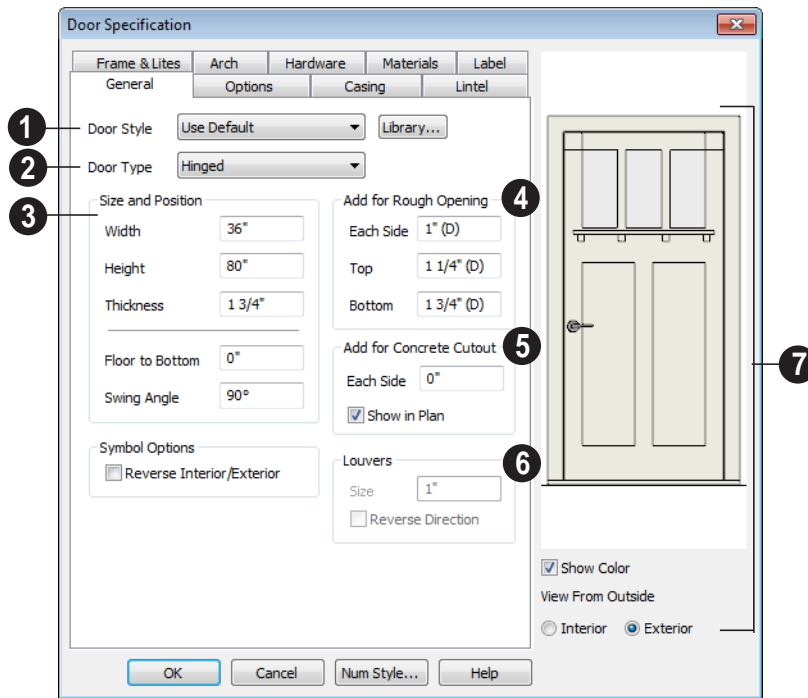

- 1 **Door Style** - Define the door as slab, glass, panel, or louvered, or select a door style from the library. Choose “Use Default” to use the default door style set in the **Door Defaults** dialog. See “Door Defaults” on page 253.
 - Select “Library” from the list or click the **Library** button to choose a door symbol from the library. Once a library door is selected, that door is added to the Door Style list. See “Select Library Object Dialog” on page 622.
- 2 **Door Type** - Specify doorway, hinged, slider, pocket, bifold, or garage door.

Slider, pocket, bifold and garage are not allowed as Exterior Door Defaults.

- 3 Specify the **Size and Position** of the selected door.
 - Specify the **Width, Height, and Thickness** of the door.
 - **Floor to Bottom** - Specify the height of the bottom of the door frame as measured from the subfloor.
 - Specify the **Swing Angle** of the selected door in floor plan view, between 0° and 180°. An angle of 0° displays the door as closed and an angle of 180° displays it as wide open. The Swing Angle for Bifold doors and double doors that swing from the center can be no more than 90°.

The Swing Angle also affects the door’s

appearance in 3D views if **Draw Closed** is unchecked on the Options tab.

6 Add for Rough Opening - Specify the amount to add to **Each Side**, the **Top** and the **Bottom** for the door's framed rough opening. The rough opening should be large enough to accommodate the door frame and space for shims. If the Bottom Rough Opening value is greater than the Floor to Bottom value, the difference is added to the top of the rough opening when framing is built.

5 Add for Concrete Cutout - Specify the amount to add to **Each Side** of the door opening when the upper part of the door is in a framed wall and the lower part is located in a concrete wall, stem wall, or garage curb. See "Garages" on page 338.

- Uncheck **Show in Plan** to suppress the display of the concrete cutout in floor plan view. See "In Floor Plan View" on page 257.

6 Louvers Size - Specify the vertical height of the selected door's louvers. Only available for doors specified as Louvered.

By default, louvers face the direction that the door swings. Check **Reverse Direction** to reverse the direction that they face.

7 A preview of the door displays on the right side of the dialog box.

- Check **Show Color** to show the door in color in the preview.
- Select **Interior** or **Exterior** to specify which side of the door displays in the preview.

Options Tab

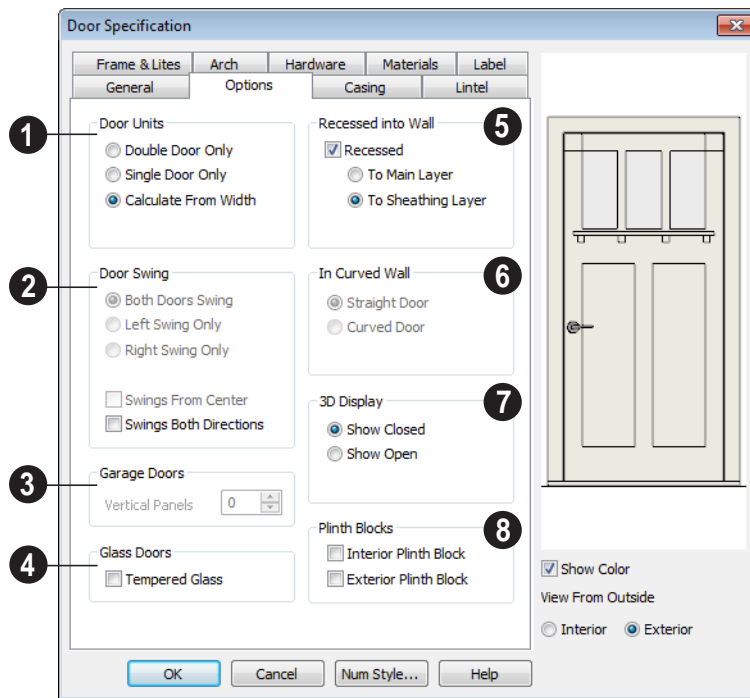

- 1 Specify the number of **Door Units** or panels that the selected door has. Not available for garage doors.
 - Select **Single Door** to force the selected hinged, pocket or bifold door to be a single door, regardless of its width.
 - Select **Double Door** to force the selected hinged, pocket or bifold door to be a double door, regardless of its width.
 - Select **Calculate From Width** to use the program defaults. Hinged, pocket and bifold doors default to **Single Door** when less than four feet (1200 mm) wide. If the width is greater than four feet, **Double Door** is the default.

- If a Slider door is selected, instead choose **Four, Three or Two Panel**.

Note: The defaults for Calculate From Width are not editable.

- 2 **Door Swing** - Specify how the selected door swings. Most options here are only available when the selected hinged or pocket door is a Double Door. Not available for bifold, slider or garage doors. See “Changing Door Swings” on page 260.
 - Check **Both Doors Swing** to allow both sides of a Double Door to swing.

- Check **Left Swing Only** or **Right Swing Only** to allow only the left or right side of a Double Door to swing.
 - Check **Swings From Center** to create a Double Door with hinges at the center rather than at the outside edges.
 - Check **Swings Both Directions** to allow a door or both sides of a Double Door to swing both directions.
- 3** Specify the number of **Vertical Panels** to be placed on a selected garage door. Only available for garage doors.
- 4** Check **Tempered Glass** to specify the selected door's glass as tempered.
- 5** The **Recessed into Wall** options allow you to recess the selected door into a wall, away from the exterior surface. Only available if the door is placed in a multi-layered wall. See "Wall Type Definitions" on page 209.

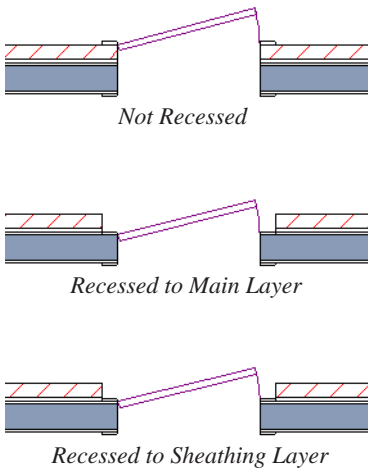

- Check **Recessed** to activate the settings that follow.
- Select **To Main Layer** to recess the door to the wall's Main Layer.
- Select **To Sheathing Layer** to recess the door to the wall's sheathing layer.

6 In Curved Wall - Specify whether a door placed in a curved wall is **Straight** or **Curved**. Curved is selected for Pocket Doors and cannot be changed. See "Drawing Curved Walls" on page 190.

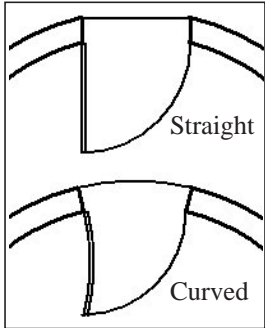

7 3D Display - Specify whether the selected door is drawn open or closed in 3D and cross section/elevation views.

If **Draw Open** is selected, the Swing Angle set on the General tab is used in 3D views.

8 Plinth Blocks - Add an **Interior Plinth Block** and/or **Exterior Plinth Block** to the selected door. Plinth blocks do not display in 3D views, but are counted in the Materials List.

Casing Tab

Changes made on the Casing tab can only be seen in 3D views.

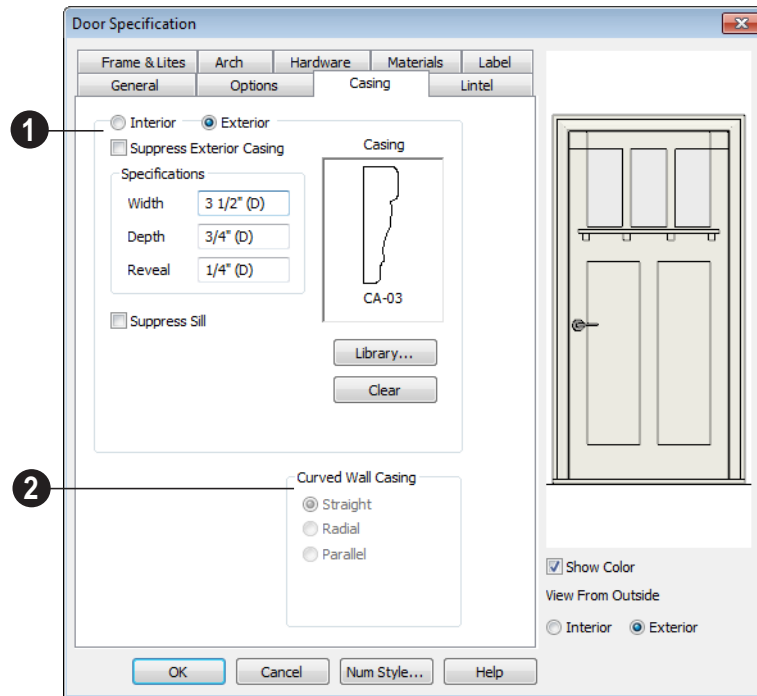

1 Specify the casing for the selected door.

- Select the **Interior** or **Exterior** radio button to define the casing for that door side and display it in the preview image. This choice is not available for interior doors, which use the same values for both sides.
- Check **Suppress Interior/Exterior Casing** to have a wrapped opening instead of casing.
- Define the **Width** of the selected casing.
- Define the **Reveal**, the distance between the inside edge of the door frame and the inside edge of the casing. Define the **Width** of the selected casing.

- Check **Suppress Sill** to prevent a sill from being generated under the door.
- Click the **Library** button to select a molding profile for the casing. A preview of the casing profile displays in the window above. See “Select Library Object Dialog” on page 622.
- Click the **Clear** button to remove a selected casing profile from the door.

2 The **Curved Wall Casing** settings are enabled if the door is placed in a curved wall. See “Drawing Curved Walls” on page 190.

Door and window casing and jamb can be constructed three ways in curved walls:

- **Straight** - Both the door and casing are straight. This can be used where the wall's curvature is not too sharp and the opening is not too wide. It cannot be selected for Pocket Doors, which must be curved if placed in a curved wall.

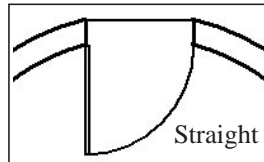

- **Radial** - A vertical surface that would be perpendicular to a straight wall has its plane pass through the wall's center of curvature.

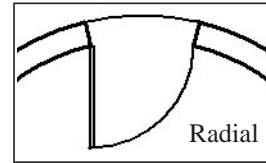

- **Parallel** - A vertical surface that would be perpendicular to a straight wall remains parallel to the line from the wall center through the opening center.

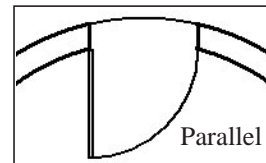

Lintel Tab

The settings on the Lintel tab allow you to assign a lintel, or top molding that meets the side casing using a butt joint instead of a

mitred joint. These settings are not available if the door has a reflected arch. See "Arch Tab" on page 274.

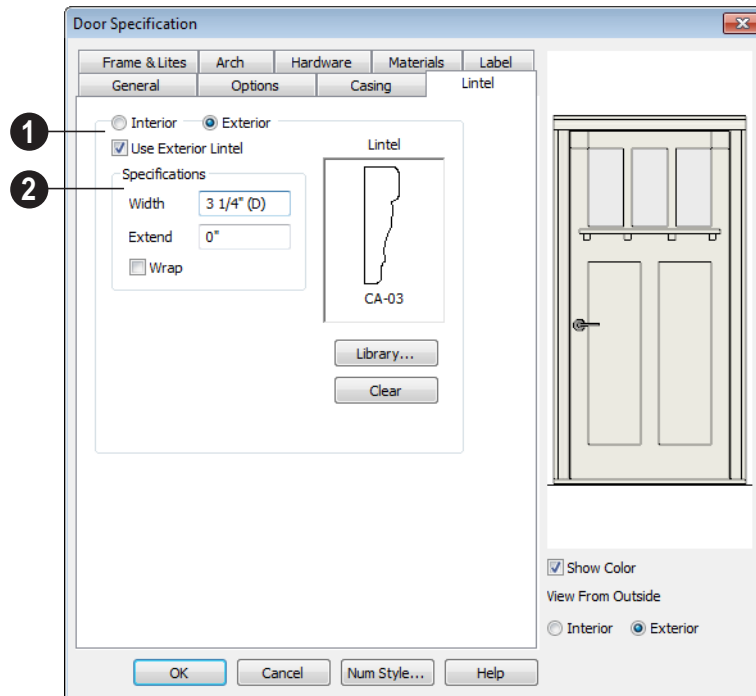

1 Select the **Interior** or **Exterior** radio button to define the casing for that door side and display it in the preview image. This choice is not available for interior doors, which use the same values for both sides.

- Check **Use Exterior/Interior Lintel** to have a lintel on the selected side of the door instead of the regular top casing.

2 Specify a lintel for the selected side of the door.

- Define the **Width** of the lintel. This value is independent of the casing's width;

however, the lintel does inherit its depth from the casing.

- Specify how far to **Extend** the lintel past the outside edges of the casing on each side.
- Check **Wrap** to wrap the lintel profile back toward the wall.
- Click the **Library** button to select a molding profile for the lintel. A preview of the selected profile displays in the window above the button.
- Click the **Clear** button to remove the selected lintel profile from the door.

Frame & Lites Tab

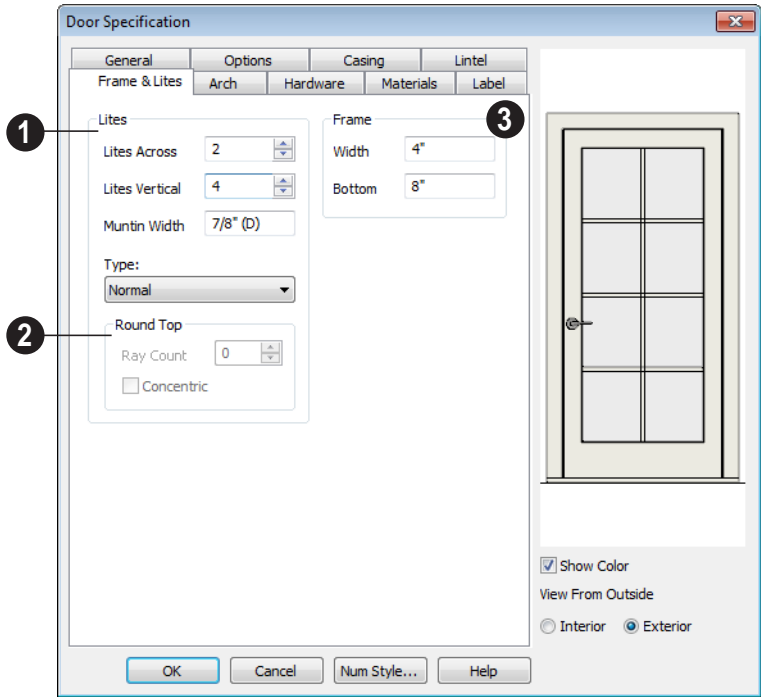

1 Specify the number of **Lites**, or panes of glass, as well as their configuration. Only available for Glass doors.

- Specify the number of horizontal **Lites Across**.
- Specify the number of **Lites Vertical**.
- **Muntin Width** - Specify the width of the muntins used to divide the lites.
- Choose a **Type**, or style, from the drop-down list.
- **Normal** style is the most common, with vertical and horizontal muntin bars.

- **Diamond** style uses angled muntins to divide the lites.
- **Prairie** style is based on the normal style, but with all the central muntins removed, leaving only the two outside muntins, both horizontally and vertically. Lites Across and Vertical are typically set between 6 and 8.
- **Craftsman** style is based on the normal style, but only the topmost horizontal muntin is kept with all the portions of the vertical muntins above it. Lites Across and Vertical are typically set between 4 and 8.

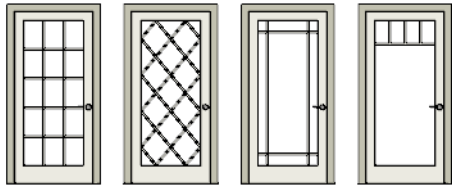

Normal Diamond Prairie Craftsman

2 If the door is defined as **Round Top** on the Arch tab, you can specify a **Ray Count** of up to 10 radial muntin bars in the portion of the door within the arch. There is one more pane of glass than the number of rays specified.

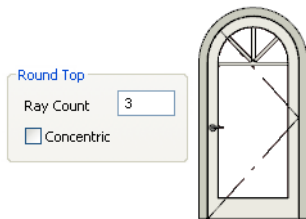

- Check **Concentric** to produce muntins radiating from a curved inner muntin that is concentric with the door's arch. You must have at least three lites across for this to be used.

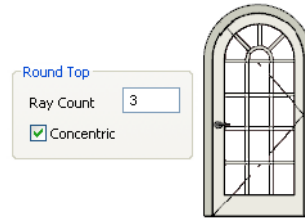

- 3 **Frame** - If the door is a glass, panel or louvered door, you can specify the dimensions of the door's rails and stiles.
- Specify the **Width** of the stiles and top rail.
 - Specify the height of the **Bottom** rail.

Arch Tab

The settings on the Arch tab are not available if the selected door is a Sliding, Bifold or Garage door. They are also unavailable if the

selected door has been assigned a lintel. See "Lintel Tab" on page 271.

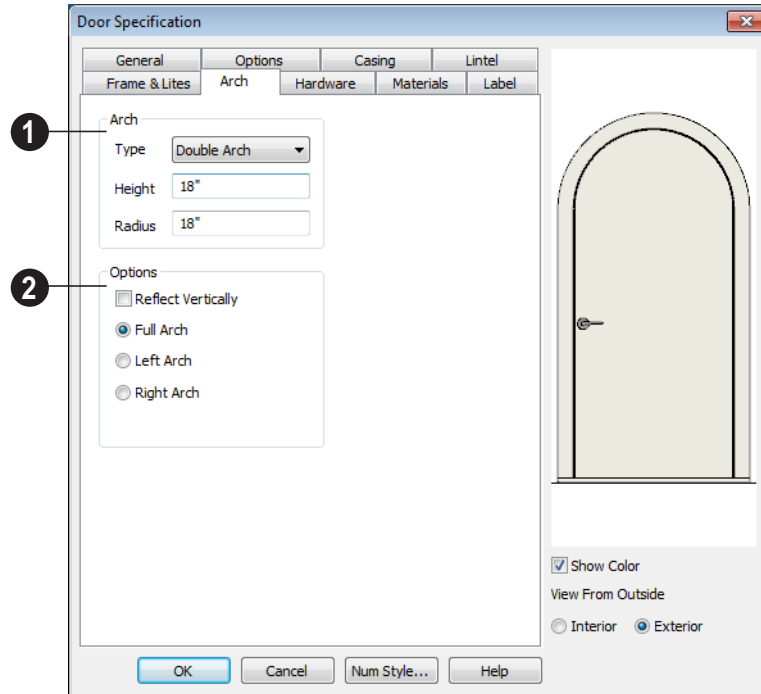

1 Define the style and size of the **Arch**.

- Select a **Type** of arch from the drop-down list.
- Specify the **Height** of the arch, as measured from the base of the arch to the top of the door. The height can be defined for all arch types except Round Top and Octagonal Arches.
- The **Radius** can also be defined for Tudor and Double Arches.

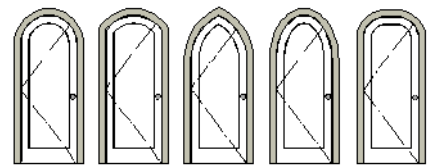

Round Top Broken Gothic Elliptical Flat Top

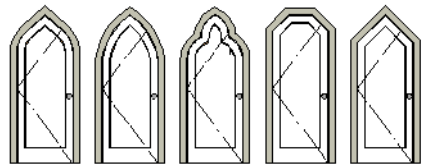

*Tudor Double Trifoil Octo-
gonal Dogear*

- 2 Options** - Define the orientation of the arch.
- Check **Reflect** to reflect the arch, top to bottom. This is rarely used for doors, but can be specified for windows to create unique configurations. Not available if a lintel is specified for the selected door. See “Lintel Tab” on page 271.

- Select **Full Arch** to produce an arch with the apex at the door’s center.
- Select **Left Arch** to produce an arch with the apex on the door’s right side.
- Select **Right Arch** to produce an arch with the apex on the door’s left side.

Hardware Tab

Many of the settings on the Hardware tab are Dynamic Defaults: if “Use Default” is selected, the setting in the **Door Defaults**

dialog is used. See “Dynamic Defaults” on page 57.

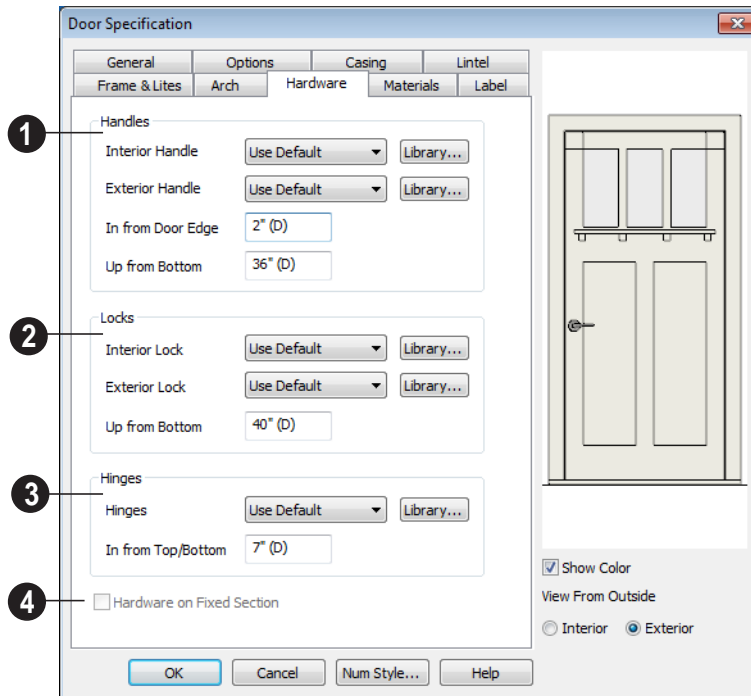

- 1** Specify the **Handles** to be used on the selected door.
- Select an **Interior Handle** and/or **Exterior Handle** from the drop-down lists.

Select “Library” or click the **Library** button to select a handle from the library. See “Select Library Object Dialog” on page 622.

- Specify the location of the door handles **In From Door Edge**.
 - Specify the location of the door handles **Up From Bottom**.
- 2 Specify the door's interior and exterior **Locks**.
 - Select an **Interior Lock** and/or **Exterior Lock** from the drop-down lists. Select "Library" or click the **Library** button to select a lock from the library.
 - Specify the location of the door locks **Up From Bottom**. The locks use the same In From Door Edge value as the handles.
 - 3 Specify the **Hinges** to be used on the door. Two hinges are placed for interior doors, and three for exterior doors.
 - Select a style of **Hinges** from the drop-down list. Select "Library" or click the **Library** button to select a hinges from the library.
 - Specify the distance **In From Top/Bottom** of the door to the center of the top and bottom hinges.

Note: For hinges to look right, it is best to have at least a 1/4" (6 mm) reveal for the interior, or hinge side, door casing.

- 4 Check **Hardware on Fixed Section** to include handles, locks, and hinges on the fixed side of a double Hinged door. Only available for Double Doors with Left or Right Swing Only selected. See "Options Tab" on page 268.

Materials Tab

The Materials tab is available for numerous objects. For more information, see "Materials Tab" on page 635.

Label Tab

Door labels display in floor plan view when the "Doors, Labels" is turned on and use the Text Style assigned to that layer. See "Door Labels" on page 258.

For information about the settings on this tab, see "Label Tab" on page 885.

Windows

Home Designer Pro can model a wide variety of windows. Fixed glass, hung, casement, sliding, awning, hopper, and louver window styles can all be created with the standard Window tool, and even set as the default. The shape of a window can be angled or made into a round top or other arch styles. Home Designer Pro can create bay, box, and bow windows at the click of a button. In addition, the library contains many mullied window combinations.

Chapter Contents

- Window Defaults
- The Window Tools
- Special Windows
- Grouped Windows
- Window Levels
- Displaying Windows
- Editing Windows
- Bay, Box, and Bow Windows
- Bay, Box, Bow Windows & Roofs
- Window Specification Dialog
- Bay/Box Window Specification Dialog
- Bow Window Specification

Window Defaults



Default Settings can be accessed by selecting **Edit> Default Settings**. Select Window from the **Default Settings** dialog and click the **Edit** button.

You can also double-click the **Window**

Tools  parent button to open the **Window Defaults** dialog.

The settings in the **Window Defaults** dialog control the attributes of a window when it is initially placed in a plan, so you should define the type of window that will be placed most often in your model. See “Default Settings” on page 56.

The tabs in the **Window Defaults** dialog are similar to those found in the **Window Specification** dialog, with one exception:

On the General tab of the **Window Defaults** dialog, you can specify the **Minimum Separation** for components windows and doors in mulled units in the plan.

Minimum Separation

The **Minimum Separation** value in the **Window Defaults** dialog specifies how close windows in a mulled unit can be to each other. This setting also determines the width

of the shared casing. If 0 is specified, no casing is created between mulled units.

For more information, see “Window Specification Dialog” on page 294.

Dynamic Window Defaults

A variety of window default values are dynamic, including the **Window Type**, **Add for Rough Opening** values, **Casing**, **Lintel** and **Sill Specifications**, **Sash & Frame** sizes, and **Treatments**. All **Materials** are also dynamic. When a dynamic default is changed, existing windows using the default value are affected. See “Dynamic Defaults” on page 57.

Window Framing

The default Rough Opening for windows can be defined in the **Window Defaults** dialogs. You can also specify an additional amount to cutout for window openings in concrete walls when the upper part of the window is located in a framed wall. See “General Tab” on page 295.

The defaults for headers can be specified in the **Build Framing** dialog. See “Framing Defaults” on page 436.

The Window Tools



To place a window, select **Build> Window** and choose the desired window type. Click on a wall to place a window of the selected type at that location.

Bay, box and bow windows can only be placed in straight walls, while standard windows can be placed in both straight and curved walls.

Standard Windows

 Select **Build> Window> Window**, then click on a straight or curved wall to place a standard window at that location.

A standard window is a single window that is not a bay, box, bow window, a corner window or a blocked unit. These special types are made up of multiple standard windows.

A standard window that is part of a special window is called a component window.

Standard windows can be specified as any of a variety of window types, such as double hung, casement and awning. See “Window Specification Dialog” on page 294.

Bay Windows

 The roof is affected by Bay, Box and Bow Windows. These windows should therefore be placed before the roof is built.

 A **Bay Window** is composed of three wall sections, each with a single component window. The two side walls are at an angle to the main wall. Select **Build> Window> Bay Window** and click on a straight wall to produce a bay window.

When initially placed, bay windows measure 2'-2" across at the front, 4'-2" across at the back, and are 1'-0" deep. The component windows are specified in the **Window Defaults** dialog and their sizes adjust to fit the available space.

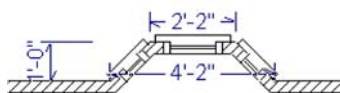

Box Windows

 A **Box Window** is a bay window with side angles set at 90°. Select **Build> Window> Box Window** and click on a straight wall to produce a box window.

Box windows initially measure 4'-2" wide with a depth of 1'-6". The component windows are specified in the **Window Defaults** dialog and their sizes adjust to fit the available space.

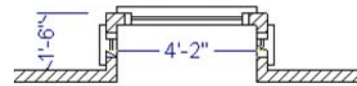

Bow Windows

 A **Bow Window** is a group of identical wall segments that form a segmented curve. Select **Build> Window> Bow Window** and click on a straight wall to produce a 5-section bow window.

Bow windows can be composed of between two and twenty sections. The number of bow window components can be changed in the **Bow Window Specification** dialog. See “Bow Window Specification” on page 313.

The component windows are specified in the **Window Defaults** dialog. Their sizes adjust to fit the available space.

The 5-section bow below has a 4'-10" radius centered 3'-9" inside the wall, giving an opening 5'-10" across and a depth of 11½".

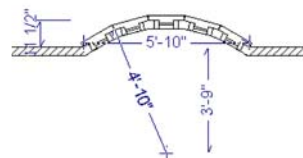

Note that for a bow with an odd number of sections, the radial dimension is from the center of the arc to an outside corner where two window sections join. The depth (11 ½") is measured to the flat area of the center section, not to a corner. As a result, the radius is a bit greater than the sum of the depth and the distance from the center of the bow's curve to the exterior of the wall.

Note: Bay, box, and bow window areas are not included in the living area or in room standard area calculations. They are included in room interior area calculations.

Pass-Thru



Select **Build> Window> Pass-Thru**, then click on a straight or curved wall to place a Pass Thru at that location.

A Pass-Thru is simply a wall opening without a window unit placed inside. Like a window, it can have casing and a sill. It does not, however, have a sash, frame, or glass. It is one of the window **Types** available in the **Window Specification** dialog. See "General Tab" on page 295.

Windows Library



Select **Library> Library Browser**, then browse to Home Designer Core Catalogs> Architectural to access a selection of special windows. Select the desired window, then click on a wall to place the window at that location.

Special Windows

A variety of special windows can be created using multiple standard windows, the edit tools or custom symbols.

Creating Manual Bay, Box and Bow Windows

Sometimes it is easier to draw bay, box and bow windows manually than to use the automatic tools. Bays created using walls can have more than one window per section, which is not possible using a bay window unit.

Bear in mind that moving a manually created bay, box or bow window is generally more difficult than moving a unit created with one

of the **Window Tools**  since it is composed of individual walls.

Corner Windows

Corner windows are produced when each window has one edge at or past the interior side of the adjacent wall.



To create a corner window, first create the desired window on each side of the corner. The header height and the sill height of both windows must be the same.



To move a window all the way into a corner, check Ignore Casing for Opening Resize in the Plan Defaults dialog. See “General Plan Defaults Dialog” on page 58.

Slant top, or shaped windows can be components of corner windows as long as their heights are equal at the corners. Windows with single or two segment tops can be used, but windows with three cannot. If a two segment window is used, the segment nearest the corner must be flat.

Once the corner window is formed, its components and corner post size can be adjusted using dimension lines. Blocked units can also meet at a corner this way.

Special Window Shapes

A selection of special shaped windows is available in the Windows Library, including arched windows and mullied units.

In addition, you can create a wide variety of window shapes in the **Window Specification** dialog, including:

- Arched windows. See “Arch Tab” on page 306.
- Trapezoidal windows. See “Shape Tab” on page 304.

Recessed Windows

A window or mullied unit placed in a brick or stone wall is often recessed into the wall’s exterior, so the brick wraps the opening.

You can specify a window as recessed in the **Window Specification** dialog. See “Options Tab” on page 296.

Placing a Gable Over a Window



Click the **Gable Over Door/Window** edit button to produce a gable roof over the selected window(s) the next time automatic roofs are built. See “Gable/Roof Lines” on page 382.

You can manually edit or delete this gable line at any time. Your changes take effect when the automatic roofs are rebuilt. This tool can also be used with group selected windows.

Stained Glass

A selection of solid stained glass materials is available in the Home Designer Core Catalogs> Materials> Glass library. See “Materials” on page 631.

Vents

A selection of attic, foundation and gable vents are available in the Library Browser. See “The Library” on page 603.

Vents are placed in the same manner as regular windows and can be edited in much the same way, as well.

Grouped Windows

Windows can be grouped together to create a wide variety of custom configurations. Stacked windows are easy to create in 3D views, particularly cross section/elevation views, using their edit handles. See “Editing Windows” on page 289.



Notice how the windows and door in this example are separate, with spaces between them. Doors and/or windows can also be organized into a unit in which there are no spaces between the windows and door units, and the casing between them is shared.

To help organize their display in floor plan view, you can place stacked windows of varying heights on different Window Levels. See “Window Levels” on page 285.

Automatically Mullered Openings

To form a mulled group of windows and/or doors, move them close enough together so that their casings touch. Once the casings touch, the windows are mulled together with one casing between the two of them.

The sill of each window in the group must be at the same level for them to share the middle casing. The casing tops do not have to be at

the same level. The casings are modeled as if they are one unit but the windows remain separate objects for dimensioning and the Materials List.

Windows can be automatically mulled to doors if the bottom of the window is at the elevation of the floor, equal to the bottom of the door.

The **Minimum Separation** value in the **Window Defaults** dialog specifies how close mulled window and door units can be to each other. Define a value that specifies the desired width for the shared casing. See “Window Defaults” on page 280.

Mulled Units in the Library

A selection of mulled window units is available in the Windows library. To place one in your plan, select it and click on a wall in any view. See “Placing Library Objects” on page 620.

Selecting Components of Mullered Units

To select a component of a mulled unit from the library, click at the location of the component in question, then click the **Select**

Next Object  edit button or press the Tab key until that individual component is selected. Only the component clicked on is selectable using this method. If you need to select a different component, click on it and repeat the process.

The selected component may be on any window level in the mulled unit. If there are multiple levels, it is easiest to select the

components in a 3D view. When you have selected an individual component, you can change its parameters in the **Window Specification** dialog. See “Window Specification Dialog” on page 294.

If the selected component is not itself a mullered unit and has no components above it, its **Height** and **Arch** parameters can be changed. Changing the Height causes the component top to move. The bottom remains stationary.

Displaying Mullered Units



As with other windows, the display of mullered window units is controlled in the **Layer Display Options** dialog. See “Displaying Objects” on page 102.

Mullered units are placed on the “Windows” layer by default and have a single label, which is on the “Windows, Labels” layer. Mullered units from the library are also included in the windows category of the Materials List. If the component objects of a mullered unit have unique moldings or materials, they will not be noted in the Materials List.

If a mullered unit includes a door, **Treat as Door** will be checked in the **Mullered Unit Specification** dialog. When this box is checked, the unit’s label is placed on the “Doors, Labels” layer but the unit itself remains on the “Windows” layer unless you change it. Units set to **Treat as Door** are also included in the Doors category of the Materials List. See “Options Tab” on page 296.

You can, if you wish, display a mullered unit’s individual component labels instead of a single label for the unit. Labels are placed on the layers they would be on were the unit not mullered. A mullered unit’s label setting also affects how it is listed in the Materials List. See “Label Tab” on page 311.

- When **Suppress All Labels** is selected, individual components are counted in the Materials List.
- When **Show Component Labels** is selected, components are counted in the Materials List.
- When **Show Single Label for Entire Unit** is selected, the unit is treated as a single object in schedules and the materials list.

Window Levels

It is often necessary to position more than one window, mullered unit, and/or door at the same location along a wall in floor plan view: for example, to create an entry with side lites and transom.

To help control and organize the appearance of stacked wall openings in floor plan view, you can assign windows at various heights to different **Window Levels**.

Window Levels do not define the height of a window, just the appearance and behavior of windows and doors in floor plan view.

- In floor plan view, windows and doors on the **Default Level** display the line color and style of the layer they are on. See “Layers” on page 101.
- Windows on any other level appear light gray, regardless of the layer they are on.

The Default Level

The **Default Level** is the Window Level that Standard Windows are initially placed on when created and affects several things:

- In floor plan view, windows and doors on the **Default Level** display the line color and style of the layer they are on.
- When you click on stacked doors and windows in floor plan view, those on the Default Level are selected first. To select an opening on another level, use the

Select Next Object  edit button. See “Select Next Object” on page 126.

Typically, the Default Level is set as 0 (zero).

Window Level Zero

Window Level 0 (zero) is the level that all bay, box and bow windows and doors are always placed on. Typically, it is also the Default Level that standard windows are placed on, as well.

Because doors are always on Level 0 and because Window Levels affect line colors in printouts, it is usually best to keep the Default Level at 0. If you do change the Default Level, remember to change it back before printing.

If you specify the Default Level as a value other than zero and then place a window in your plan, it will not use all Window Defaults settings. Instead:

- The program will position it above any windows that are at the same location but on a lower level rather than use the default Floor to Top height;
- Its Type will be Fixed Glass;
- Its Height will be 12” (300 mm);

- It will have no Sill.

Once the window is created, its parameters can be changed. See “Editing Windows” on page 289.

Using Window Levels

The door and windows in the illustration below were created on different Window Levels.

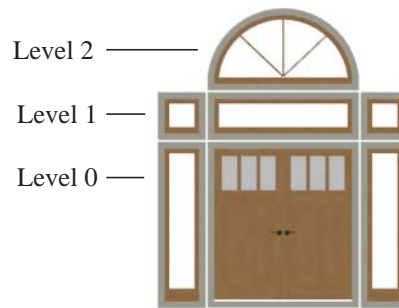

To stack windows using Window Levels

1. Place the door and side lites on Window Level Zero.
2. Open the **Window Defaults** dialog and change the Default Level to 1.
3. Place the second row of windows above the door and side lites on Level Zero. The program will automatically position fixed glass windows above the door and side lites.
4. Edit these fixed glass windows’ Widths and other attributes as needed.
5. Open the **Window Defaults** dialog and change the Default Level to 2.
6. Place the top window above the others. The program will place a fixed glass window above the windows on Level 1.

7. Edit this window's Arch and other attributes as needed.
8. When you are finished, open the **Window Defaults** dialog and change the Default Level back to 0.

Displaying Windows



The display of windows, window labels, openings, casing, and headers in floor plan and 3D views can be controlled in the **Layer Display Options** dialog. See “Layer Display Options Dialog” on page 104.

Windows can only be placed in walls, so if a wall's layer is turned off, any windows placed in that wall will not display, either. See “Displaying Walls” on page 192.

If the “Windows” layer is not set to display, window casing and other components are not visible, but the openings in the walls where they are located can still be seen.

In Floor Plan View

A window's frame, glass, casing, and sill are all represented in floor plan view. This makes some window types, notably Sliding and Double and Triple Casement windows, distinguishable.



Double Hung

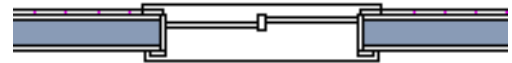

Left Sliding

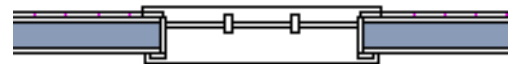

Triple Casement

Window types in floor plan view

Bay, box, and bow windows have dimensions lines associated with them.

- You can suppress their display by turning off the “Manual Dimensions” layer or on a unit by unit basis in the unit's specification dialog. See “Bay/Box Window Specification Dialog” on page 311.
- The arrow style and fill are set in the **Dimension Defaults** dialog. See “Dimension Defaults Dialog” on page 720.

Windows in pony walls display in floor plan view regardless of which part of the pony wall is visible. If you wish, you can instead display only openings located entirely in the portion of a pony wall that is set to display in floor plan view. See “Pony Wall Defaults” on page 178.

If a window is placed in a Garage room at a height where it extends into the stem wall or curb, a cutout in the concrete will display on the floor below. You can specify the cutout's size and whether it displays in floor plan view in the **Window Specification** dialog. See "General Tab" on page 295.

Interior and exterior window casings will display in all views when the "Casings, Exterior" and "Casings, Interior" layers are turned on. In floor plan view, the sills and vertical side casings will be shown, but the horizontal top casing or lintel will not.

In 3D Views

To show opening indicator arrows in Vector Views, turn on the "Opening Indicators" layer in the **Layer Display Options** dialog. See "Vector View" on page 711.

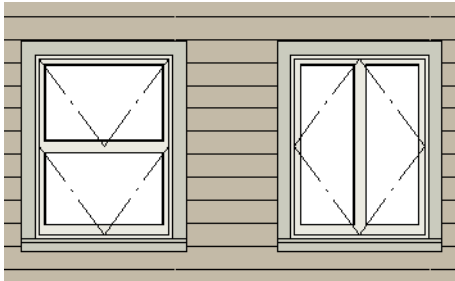

Windows showing opening indicators

You can change the direction of indicator arrows in the **Preferences** dialog. See "Architectural Panel" on page 73.

You can also specify whether window and door glass is opaque or transparent in Vector Views in the **3D View Defaults** dialog. See "Options Tab" on page 669.

Window Labels

Window labels display in floor plan view, centered on the windows they represent, when the "Windows, Labels" layer is turned on. Window labels use the Text Style specified for this layer, as well. See "Object Labels" on page 884.

Automatic window labels indicate Width and Height, followed by Type. For example:

- In Imperial plans, the automatic label for a 3'-0" wide, 4'-0" high double hung window will read 3040 DH.
- In metric plans, the automatic label for a 900 mm wide, 1200 mm high double hung window will read 900x1200 DH.

You can specify whether a Bay, Box or Bow Window displays a single label or displays the labels of its component windows and/or doors.

- When **Suppress All Labels** is selected, individual components of Bay, Box and Bow Windows are counted in the Materials List.
- When **Show Component Labels** is selected, components of Bay, Box and Bow Windows are counted in the Materials List.
- When **Show Single Label for Entire Unit** is selected, the Bay, Box or Bow Windows has one label in floor plan view but each component is counted separately in the materials list.

These options are also available for mullied units but affect their display the materials list somewhat differently. See "Displaying Mullied Units" on page 285.

Customized labels as well as label position and orientation can also be specified in the **Window Specification** dialog.

Editing Windows

Before a window can be edited, it must be selected. Click on a window when the **Select**

Objects  tool or any of the **Window**

Tools  are active. Doors and/or windows can also be group-selected and edited. See “Selecting Objects” on page 124.

To select a window that is part of a blocked unit, click the component window, then click the **Select Next Object**  edit button. See “Selecting Components of Muller Units” on page 284.

Windows can be edited using their edit handles, the edit toolbar buttons, and the **Window Specification** dialog. See “Window Specification Dialog” on page 294.

When you select a window in floor plan view, the window size label displays the width followed by the height. For example, a 3036 window is 3’-0” wide by 3’-6” high.

In the Specification Dialog

 The most precise method of editing an individual window or group of windows is to use the **Window Specification** dialog. The window type, size, casing, materials, shape, and more can all be specified in this dialog. See “Window Specification Dialog” on page 294.

Using the Mouse

- In floor plan view, click either of the two end handles and drag along the wall to change the width. The label showing the size updates as the window is resized.
- In 3D views, a selected window has five edit handles: the Move handle at the center and a Resize handle on each edge. Click and drag an edge handle to resize the window.
- Using the edit handles, a window resizes according to the currently active **Edit Behavior** . See “Edit Behaviors” on page 120.

Note: Using the edit handles is the only way to resize bay, box and bow window systems.

- A single window or a group of windows can be moved with the center edit handle.
- A door or window moved against an intersecting wall temporarily stops when it is the casing distance from the intersecting wall. You can continue to drag and it resumes movement past or onto the intersecting wall. Enable **Ignore Casing for Opening Resize** in the **Plan Defaults** dialog to turn off this behavior. See “General Plan Defaults Dialog” on page 58.

Using Dimensions





Like various other objects, windows can be moved using dimensions. See “Moving Objects Using Dimensions” on page 737.

You can specify how windows and doors are located by dimensions in the **Dimension Defaults** dialog. See “Locate Objects Tab” on page 723.

Dimensions can be set to locate the centers, sides, casing, or rough opening of wall openings, or you can choose to not locate openings at all. If you wish, you can move a dimension’s extension lines to locate non-default locations on a window after the dimension is drawn. See “Editing Extension Lines” on page 735.

Using the Edit Tools

A selected window or windows can be edited in a variety of ways using the buttons on the edit toolbar. See “The Edit Toolbar” on page 29.

- Click the **Gable Over Door/Window**  to create a gable over the selected window(s) the next time the roof is rebuilt. See “Gable/Roof Lines” on page 382.
- Click the **Components**  edit button to modify or add information related to the selected window in the Materials List. See “Components Dialog” on page 901.

Window Casing & Sills

Windows often feature casing, or trim, on both sides of the wall opening as well as a sill on one or both sides.

The default casing for windows is a basic rectangular stock profile. You can specify a window’s casing profiles in the **Window Specification** dialog, or you can choose to suppress casing altogether. See “Casing Tab” on page 297.

A separate molding profile can be specified for the lintel, or top horizontal molding. A sill profile can be specified, as well. See “Lintel & Sill Tab” on page 299.

Bay, Box, and Bow Windows



Bay, Box and Bow Windows are created much the way regular windows are: select a tool, then click a wall to place that window type.

Home Designer Pro automatically builds a foundation under bay/box/bow windows placed on floor 1 unless they are raised from their original position. That section of the foundation wall is also a bay/box/bow, but without windows. If the foundation was generated before the window is placed, the

foundation must be rebuilt or edited manually.

Editing Bay, Box and Bow Windows

Bay, box and bow windows are edited similar to regular windows, with one exception: in floor plan view, a diamond-shaped Depth edit handle displays on the section. Drag this Depth handle outward to increase the depth, or inward to decrease the

depth of the unit. See “Editing Windows” on page 289.

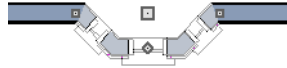

Depth edit handle on a bay window

Bay, box and bow windows can also be edited in their respective specification dialogs. See “Bay/Box Window Specification Dialog” on page 311 or “Bow Window Specification” on page 313.

Displaying Bay, Box and Bow Windows

The display of bay, box and bow windows is controlled in the **Layer Display Options** dialog. See “Layer Display Options Dialog” on page 104.

Like other windows, bay, box and bow windows can display labels. See “Window Labels” on page 288.

Bay, box and bow window width and radius dimensions, which display in floor plan view, are placed on the “Dimensions, Manual” layer. See “Displaying Objects” on page 102.

Component Windows

A component window within a bay, box or bow window can be resized like any other standard window. To select a component window, click at the location of the component in question, then click the **Select Next Object**  edit button or press the Tab key.

- Only the bay or box window component that was clicked on is selected using this method. If you need to select a different component, click on it and repeat the process.
- In a bow window, all components are identical, so only one component can be selected. Changing this component changes them all.

Resizing Components

An individual component window can be resized using the edit handles, by changing settings in the component’s **Window Specification** dialog, or by using the **Transform/Replicate Object** dialog. See “Transform/Replicate Object Dialog” on page 166.

When a bay/box/bow window is first created, there is room for one standard trimmer on each side of each component window. When the bay as a whole is moved and resized, its components automatically resize so that a standard trimmer is still accommodated.

If you increase a component window’s width to the point where there is not enough room for standard trimmers, a thinner trimmer can be used. The size of this thinner trimmer is specified in the **Build Framing** dialog. See “Openings Tab” on page 448.

If a component window is resized, it retains its size if at all possible when the containing bay/box/bow window is moved or resized. If the bay is resized in such a way that the component is too large to fit even with a thinner trimmer, the component resumes its default behavior, resizing as the containing bay window is resized.

Floors and Ceilings

When originally created, the floor and ceiling within a bay, box, or bow window are the same heights as the floor and ceiling of the room in which it is placed.



Both the top and bottom heights of these window units can be adjusted in a 3D view using the window's edit handles to create a lowered ceiling and/or a bench seat or garden window.



When the ceiling is lowered, the top heights of the walls that define the window unit are also lowered. When a roof is built over the unit, its height will be affected, as well.

When the bottom of the window is raised to create a bench seat, the unit's walls will not reach the ground. As a result, window units with bench seats will have no foundation beneath them when the foundation is built.

Bay, Box, Bow Windows & Roofs

Several different roof styles can be specified for bay, box and bow window units in the **Bay/Box** and **Bow Specification** dialogs. See "General Tab" on page 312 and "General Tab" on page 313.

If you change a bay, box, or bow window's roof specification, you will need to rebuild the roofs to see the changes. See "Rebuilding Roofs" on page 355.

roof directives need to be selected in the specification dialog to produce this roof.

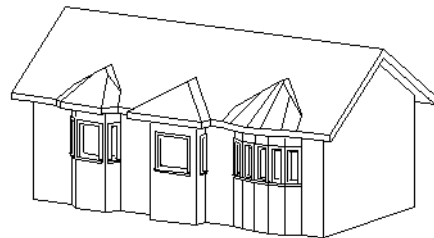

Hip Roofs

By default, a hip roof is built above the unit when roofs are automatically generated. No

Use the Existing Roof

To generate a standard roof that ignores a bay, box, or bow window, check **Use Existing Roof**.

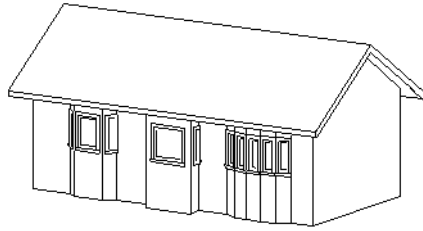

With this option the bay, box, or bow windows is tucked under the roof eave. You may find it helpful to increase the width of the eaves. See “Roof Tab” on page 356.

Extend the Existing Roof

To have the main roof extend down over the window unit and follow the shape of the unit, select **Extend Existing Roof Over**.

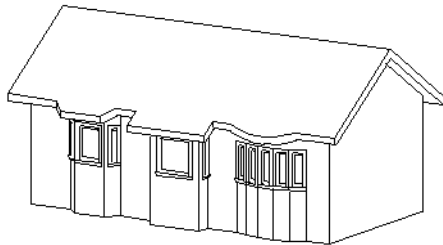

For this roof style, the ceiling heights of the window unit and the adjacent room must be the same. If you lower the ceiling of the window unit and then build the roof, a lower hip roof over the window is created. See “Floors and Ceilings” on page 292.

If a header is desired over the window unit, first build the roof, then lower the ceiling of the window unit. Once the ceiling is lowered,

select **Rebuild Walls/Floors/Ceilings** . Do not rebuild roof planes.

Rectangular Hip Roofs

To create a rectangular-shaped hip roof above a bay, box, or bow window, select **Rectangular Roof Over**.

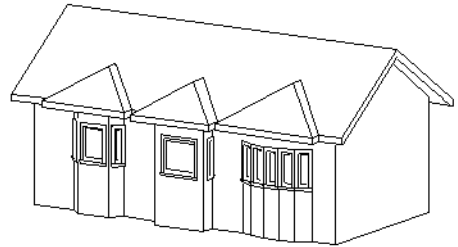

Extend Existing Roof - Rectangular

To extend the main roof down over a window unit to create a rectangular roof over it rather than one that follows its shape, select both **Extend Existing Roof over** and **Rectangular Roof Over**.

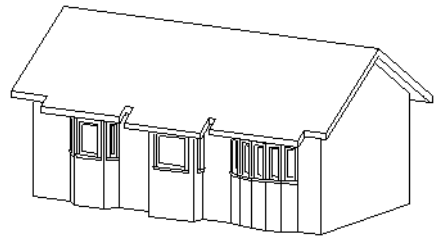

Gable Roof

A gable roof is not one of the automatic options for the roof above a bay, box or bow window. A gable can be created by manually editing the rectangular hip roofs that are automatically created. See “Roof Planes” on page 362.



To create a gable over a bay window

1. Select the front ridge corner handle of each side hip roof plane and drag the edge forward until the fascia snaps to the edge of the front hip section.
2. Delete the front hip section.
3. Adjust the roof's overhang as needed.



 To create a gable roof over a normal window, use the Gable Over Door/Window edit button. See “Gable/Roof Lines” on page 382.

Window Specification Dialog

 To open the **Window Specification** dialog, select a window or a group of windows and click the **Open Object** edit button or double-click the window using the **Select Objects**  or a **Window**  tool.

The settings in this dialog are similar to those in the **Window Defaults** dialog. See “Window Defaults” on page 280.

The settings in this dialog are also similar to those in the **Mulled Unit Specification** dialog for mulled units. Although similar, a number of the options cannot be edited when a mulled unit is selected. See “Grouped Windows” on page 284.

General Tab

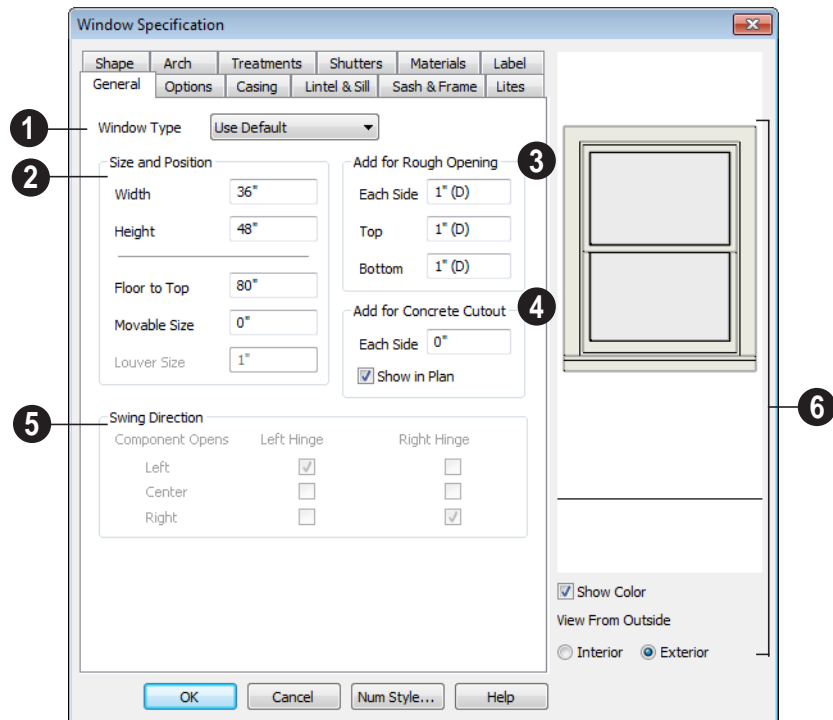

1 Window Type - Select the type of window from the list. The first entry in the list is the Default type set in the **Window Defaults** dialog.

2 Specify the **Size and Position** of the selected window.

- Specify the **Width** and **Height** of the window.
- **Floor to Top** - Specify the height of the top of the window frame as measured from the subfloor.
- **Movable Size** - Specify the dimension of the movable portion of the window. A value of 0 defaults the movable size to whatever is normal for that type of win-

dow. Not available for Fixed Glass, Single or Double Casement, Single Awning or Hopper, Louvered, Pass-Thru or mullied units.

- **Louver Size** - Specify the vertical height of the selected window's louvers. Only available for Louvered windows.

3 Add for Rough Opening - Specify the amount to add to **Each Side**, the **Top** and the **Bottom** for the window's framed rough opening. The rough opening should be large enough to accommodate the window frame and space for shims.

4 Add for Concrete Cutout - Specify the amount to add to **Each Side** of the

window opening when the upper part of the window is in a framed wall and the lower part is located in a concrete wall, stem wall, or garage curb. See “Garages” on page 338.

- Uncheck **Show in Plan** to suppress the display of the concrete cutout in floor plan view. See “In Floor Plan View” on page 287.
- 5** **Swing Direction** - Select from the available hinge options. The preview in the dialog updates as options are changed.

Only available for Casement, Double and Triple Awning, and Double and Triple Hopper windows.

- 6** A preview of the selected window displays here.
- Check **Show Color** to show the window preview in color.
 - Select **Interior** or **Exterior** to specify which side of the window displays in the preview.

Options Tab

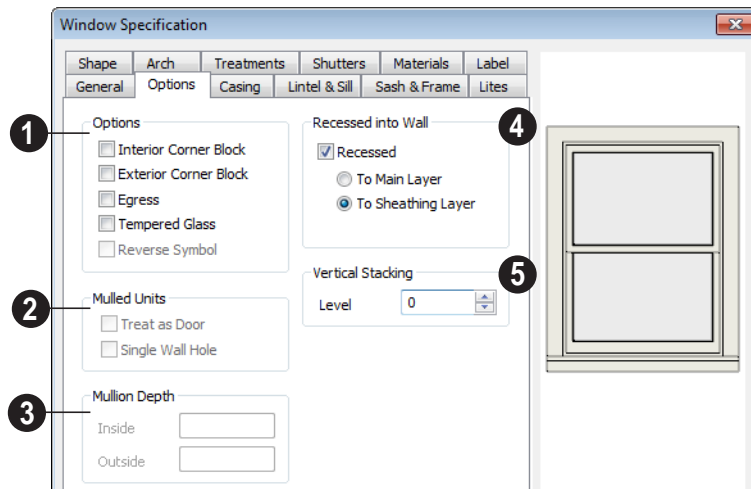

- 1** **Options** -
- Check **Interior Corner Block** to count interior corner blocks in the materials list. These do not display in 3D views.
 - Check **Exterior Corner Block** to count exterior corner blocks in the materials list. These do not display in 3D views.

- Check **Egress** to specify the window as an egress window in the Materials List. Not available for Pass-Thrus.

 Consult your local building and fire code authorities for your local egress window requirements.

- Check **Tempered Glass** to specify the selected window’s glass as tempered.

- Check **Reverse Symbol** to reverse the window as though it were reflected about a vertical line through its center.
- 2** The **Mulled Units** options are available when a mullied unit is selected.
- Check **Treat as Door** to include the unit in Door category of the Materials List rather than in the Materials List category. Only available when the selected unit contains a door.
 - Uncheck **Single Label** to produce labels and Materials List entries for each component of the unit. When checked, the unit is treated as a single object for labeling in floor plan view and in the Materials List.
 - Uncheck **Single Wall Hole** to produce individually framed wall openings for each unit in a mullied unit. When this box is checked, a single wall opening with one header for the entire unit is produced.
- 3** Specify the **Mullion Depth** for the casing between the components of a blocked unit, measured from wall surface. Positive values move the mullion surface towards the wall center; negative values, away from it. Only available when a mullied unit is selected.
- Specify the **Inside** depth of the mullion on the interior surface of the wall.
 - Specify the **Outside** depth of the mullion on the exterior surface of the wall.
- 4** The **Recessed into Wall** options allow you to recess the selected window or mullied unit into a wall, away from the exterior surface. Only available if the window or mullied unit is in a multi-layered wall. Check **Recessed** to enable these options.
- Select **To Main Layer** to recess the window to the wall's Main Layer.
 - Select **To Sheathing Layer** to recess the window to the wall's sheathing layer.

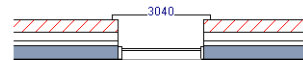

Not Recessed

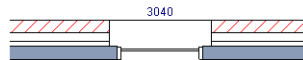

Recessed (to Main Layer)

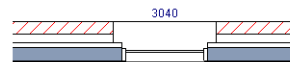

Recessed to Sheathing Layer

- 5** **Vertical Stacking** - Specify the window **Level** that the selected window is placed on. See “Window Levels” on page 285.

Casing Tab

Changes made on the Casing tab can only be seen in 3D views.

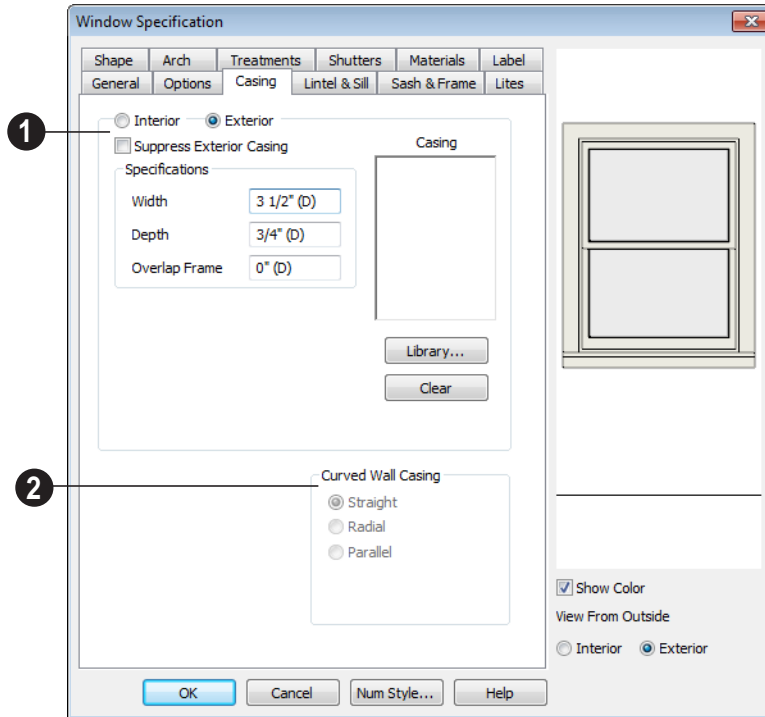

- 1 Specify the casing for the selected window or mullied unit.
- Select the **Interior** or **Exterior** radio button to define the casing for that window side and display it in the preview image.
 - Check **Suppress Exterior/Interior Casing** to have a wrapped opening instead of casing on the selected side of the window.
 - Define the **Width** of the selected casing, including the Apron, if one is being used. If a Lintel is defined, this setting does not affect the top. See “Lintel & Sill Tab” on page 299.
 - Define the **Depth** of the selected casing, as measured from the back to the front of the casing profile. This setting also

affects the lintel, sill, and apron if specified. See “Lintel & Sill Tab” on page 299.

- Define the **Overlap Frame** value, which is the the distance between the outside edge of the window frame and the inside edge of the casing. The default is 0”, which places the inside edge of the casing against the outside edge of the frame.

Type a positive value to overlap the casing over the frame by that amount.

Type a negative value to produce a gap between the casing and the frame.

To produce a reveal of a certain width, subtract the desired reveal from the total

width of the frame and type the result here.

- Click the **Library** button to select a molding profile for the casing. A preview of the casing profile displays in the window above.
- Click the **Clear** button to remove a selected casing profile from the window.

2 Door and window casing and jamb can be constructed three ways in curved walls:

- **Straight** - Both window sash and casing are straight. Straight casing may not fit properly into a wall if the window is too wide or the curvature of the wall, too tight.

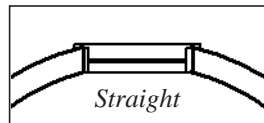

- **Radial** - The sides of the casing or jambs are inserted in the wall at an angle that passes through the center of the curve.

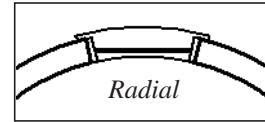

- **Parallel** - The sides of the casing are inserted in the wall at a right angle to the line tangent to the curved wall at the center of the window.

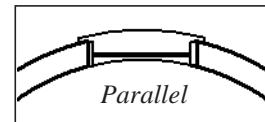

Normally, parallel casing has a straight sash. Radial casing is more like traditional curved windows, and typically has a curved sash.

Lintel & Sill Tab

The settings on the Lintel tab of the **Window** and **Mulled Unit Specification** dialogs allow you to assign a sill and lintel, or top molding that meets the side casing using a butt joint

instead of a mitred joint. These settings are not available if the window has been assigned a reflected arch. See "Arch Tab" on page 306.

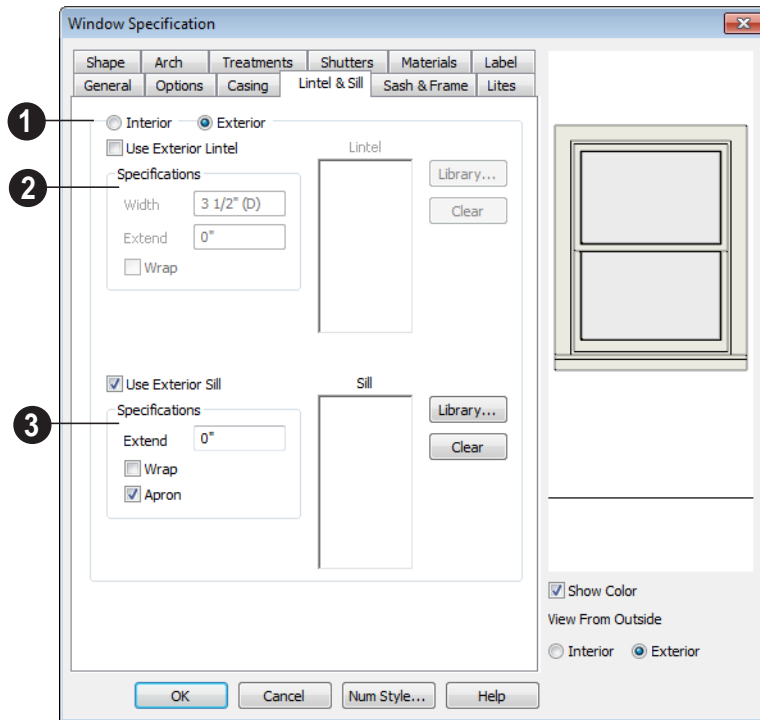

1 Select the **Interior** or **Exterior** radio button to define the lintel and/or sill for that window side and display that side in the preview image.

- Check **Use Exterior/Interior Lintel** to have a lintel on the selected side of the window instead of regular top casing.

2 Specify a lintel for the selected window or mullid unit.

- Define the **Width** of the lintel. This value is independent of the casing's width; however, the lintel does inherit its depth from the casing.
- Specify how far to **Extend** the lintel past the outside edges of the casing on each side.

- Check **Wrap** to wrap the lintel profile back toward the wall.
- Click the **Library** button to select a molding profile for the lintel. A preview of the selected profile displays in the window to the left of the button.
- Click the **Clear** button to remove the selected lintel profile from the window.

3 Specify the sill for the selected window or mullid unit.

- Check **Use Exterior/Interior Sill** to have a sill on the selected side of the window.
- Specify how far to **Extend** the sill past the outside edges of the casing on each side.

side. If an Apron is specified, it will also be affected by this setting.

- Check **Wrap** to wrap the sill profile back toward the wall.
- Check **Apron** to include an apron under the sill. When Wrap is checked, the Apron will always be 1/2" (12 mm) shorter than the sill on each side; when Wrap is unchecked, it will be the same length as the sill.
- Click the **Library** button to select a molding profile for the sill. A preview of the sill profile displays in the window to the left of the button.
- Click the **Clear** button to remove the selected sill profile from the window.

Sash & Frame Tab

The settings in the Sash & Frame tab are not available in the **Mulled Unit Specification** dialog.

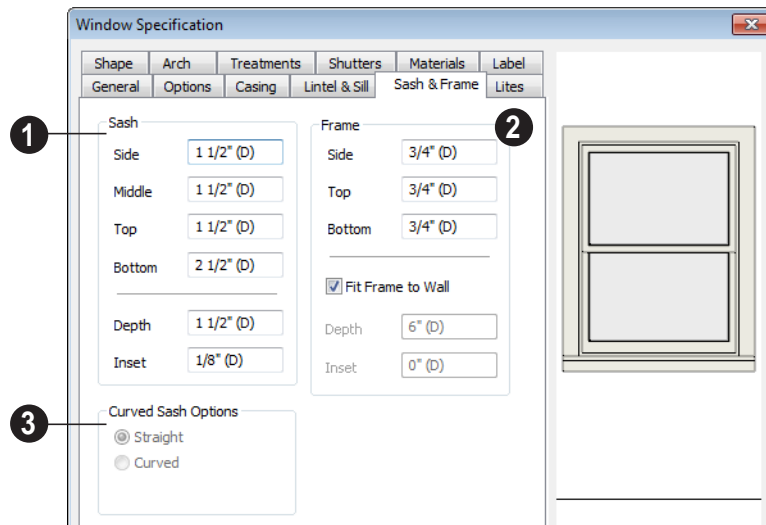

- 1 Specify the size and position of the **Sash**. Increasing the Side, Middle, Top or Bottom decreases the area of the glass.
- Specify the **Side** width of all vertical sash members: those at the window sides as well as the central members of casement and sliding windows. This is also the width of the top portion of the window when an arch is specified.
 - Specify the **Middle** width of horizontal components between the top and bottom sash in double hung, double and triple awning, and double and triple hopper windows. It does not affect casement and sliding windows.
 - Specify the **Top** and **Bottom** sash widths. The **Top** value is not used if the window has an arch.

- Specify the **Depth**, or thickness, of the sash stock measured from the exterior to the interior.
 - Specify the **Inset**, the distance between the frame and the outermost sash. If there is no frame, the inset is measured from the outer surface of the wall's main layer.
- 2** Specify the size and position of the **Frame**. If this value is set to zero, the wall's main layer thickness is used as the frame depth.
- Specify the **Side, Top and Bottom** widths of the window frame.
 - Uncheck **Fit Frame to Wall** to specify the Depth and Inset of the selected window's frame. When this box is checked, the frame's outside surface aligns with the outer surface of the wall layer outside of the Main Layer, and its depth extends to the wall's interior surface.
 - Specify the frame **Depth**.
 - Specify the distance that the frame is **Inset** from the exterior of the wall's Main Layer. When this value is 0, the outer surface of the frame aligns with the outer surface of the Main Layer. A positive value moves the frame towards the wall's

interior while a negative value moves it towards the exterior.

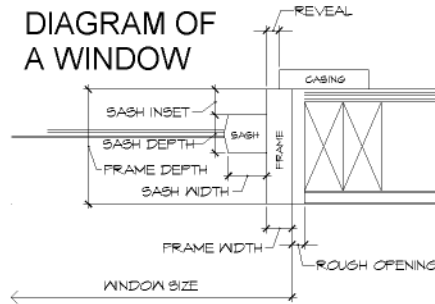

- 3 Curved Sash Options** - Specify whether a window placed in a curved wall is also curved or is straight. Normally, a curved sash is used with radial casing. See "Casing Tab" on page 297.

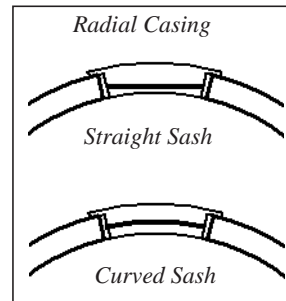

Lites Tab

The Lites tab allows you to add muntins to various window styles. There are four possible styles of muntin bars for regular windows, plus two additional options for arch top or round top windows.

A window that has been modified using the Shape tab cannot have divided lites or shutters added.

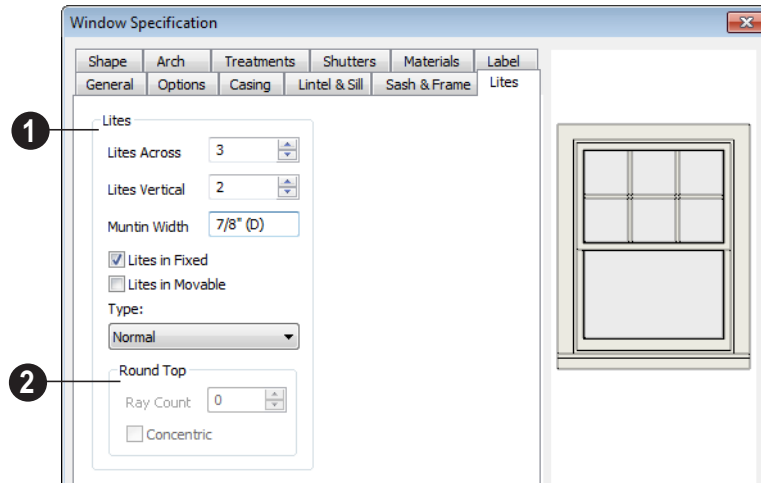

- 1 Specify the number, position and style of **Lites** for the selected window.
 - Enter the number of horizontal **Lites Across** in each sash.
 - Enter the number of vertical **Lites Vertical** in each sash.
 - Specify the **Muntin Width**, which is the width of the bars dividing the panes of glass.
 - Check or uncheck **Lites in Fixed** and **Lites in Moveable** to specify either one or both of the sashes to have divided lites.

Note: Because the fixed window in a Triple Sliding window is twice the size of the movable windows, the fixed section has a vertical muntin bar. To eliminate this, clear the Lites in fixed check box.

- 2 Select a **Type**, or style, of window lite from the drop-down list.

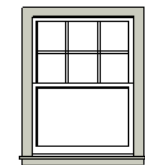

Lites in Fixed

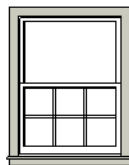

Lites in Movable

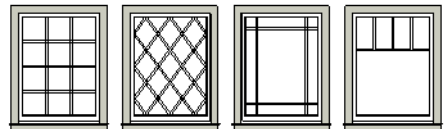

Normal Across = 3 Vertical = 4	Diamond Across = 3 Vertical = 3	Prairie Across = 6 Vertical = 8	Craftsman Across = 4 Vertical = 3
--------------------------------------	---------------------------------------	---------------------------------------	---

- **Normal** style is the most common, with muntins going horizontally and vertically. Colonial windows are an example of the normal style.
- **Diamond** style uses angled muntin bars to divide up the lites. French windows are an example of the diamond style.

- **Prairie** style is based on the normal style, but with all the central muntin bars removed, leaving only the two outside muntin bars both horizontally and vertically. Typically, both Lites Across and Lites Vertical should be set between 6 and 8. Federal or Federation windows are an example of the Prairie style.
- **Craftsman** style is based on the normal style, but only the topmost horizontal muntin bar is kept with all the portions of the vertical muntin bars above it. Typically, both Lites Across and Lites Vertical should be set between 4 and 8.

3 If the window is defined as **Round Top**, you can specify a **Ray Count** of up to 10 radial muntin bars in the portion of the window within the arch. There is one more pane of glass than the number of rays specified. See “Arch Tab” on page 306.

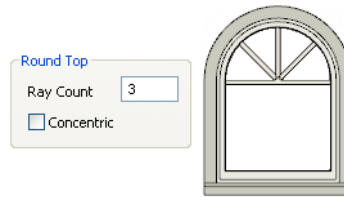

- Check **Concentric** to produce muntins radiating from a curved inner muntin that is concentric with the window’s arch. You must have at least three lites across for this to be used.

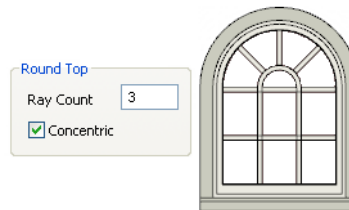

Shape Tab

Any type of non-symbol window may be shaped. All “shaped” windows are defined as “Fixed Glass” on the General tab.

If the selected window has an arch assigned to it on the Arch tab and changes are made on Shape Tab, the window will lose its arch assignment.

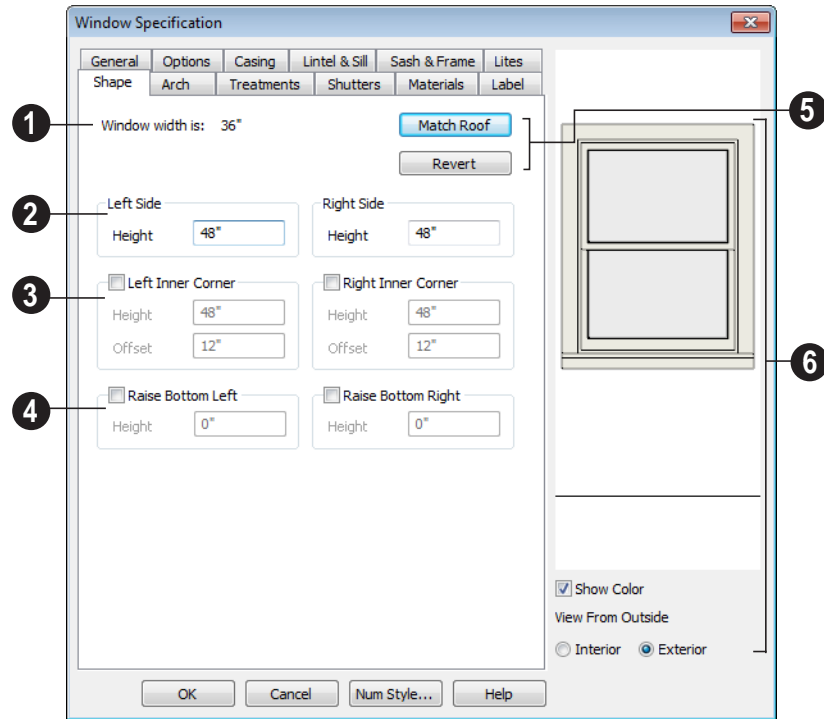

- 1 **Window Width** displays for reference. It can be changed on the General tab.

Note: The Left Side settings for a window's Interior affect the Right Side settings for its Exterior, and vice versa.

- 2 **Left Side** - Specify the **Height** of the left upper corner, as measured from the bottom of the window. Unless changed, this matches the window height. Minimum value is 1/4" (4 mm).

The height of the **Right Side** can be specified in a similar manner.

- 3 Check **Left Inner Corner** to add an additional corner along the top edge.

- Specify the **Height** of the left inner corner, as seen from the exterior, measured from the bottom of the window.
- Specify the **Offset** of the left inner corner, as measured from the left side of the window. Minimum value is 1" (10 mm).

An additional **Right Inner Corner** can be specified in a similar manner.

- 4 Check **Raise Bottom Left** to raise the height of the bottom left corner.
- Specify the **Height** of the bottom left corner, as seen from the exterior, measured from the bottom of the window. This value cannot exceed the Height of the Left Side.

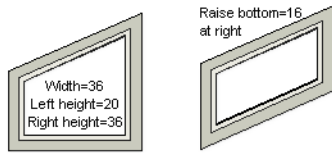

The height of the **Bottom Right** corner can be raised in a similar manner.

5 Click **Match Roof** to match the angle of the top of the window to the pitch of the roof on a gable end. The window maintains the angle even when resized and repositioned. Left and Right Inner Corner must both be unchecked for this to work. This option does not work for curved roofs.

- Click **Revert** to restore the window to its original shape, type and arch settings.

A shaped window must have two vertical sides at least 1/4" high.

The following diagram represents added Inner corners using open circles and the left and right corners using solid black circles:

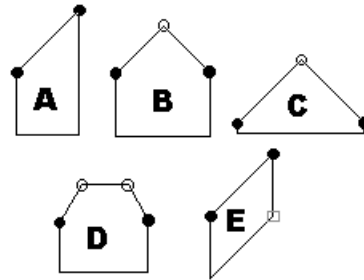

- **A** has different left and right heights with no Inner corner added.
- **B** has matching left and right heights with an added Inner corner.
- **C** is the same as **B**, except that the left and right heights have been shortened to 1/4".
- **D** is the same as **B** except it has two added Inner corners.
- **E** is the same as **A** except that Raise Bottom Right has been defined.

- 6 A preview of the selected window displays here.
- Check **Show Color** to show the window preview in color.
 - Select **Interior** or **Exterior** to specify which side of the window displays in the preview. This can significantly affect a shaped window's appearance in the preview, as the Left and Right Side settings refer to the side of the window shown in the preview.

Arch Tab

The settings on Arch tab of the **Mulled Unit Specification** dialog define the overall shape of the blocked unit's top. If the mulled unit

already includes a component window with an arch, these settings cannot be modified.

A window that has been modified using the Shape tab cannot have an arched top.

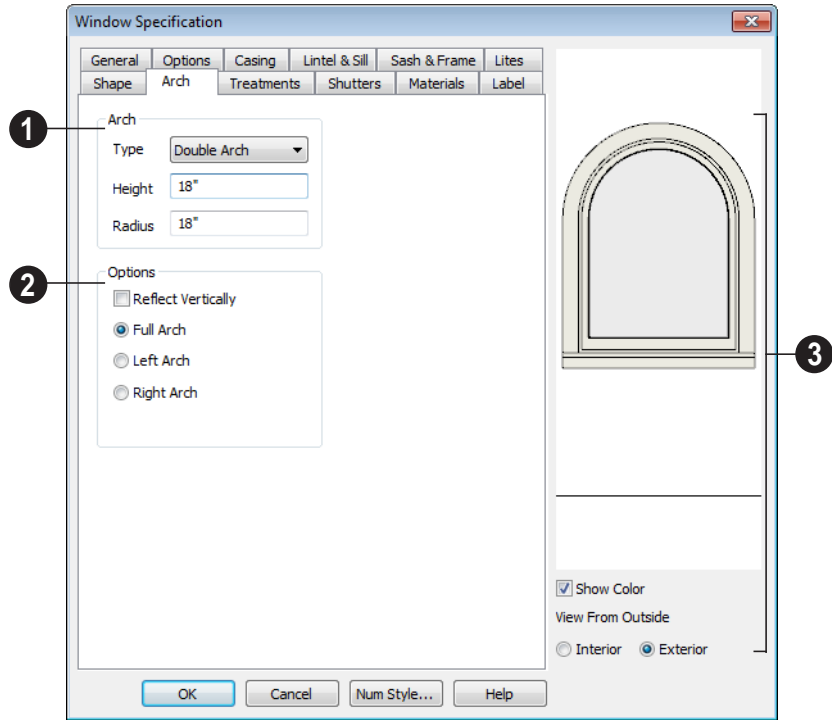

1 Define the style and size of the **Arch**.

- Select the **Type** of arch desired from the drop-down list.



Round Top Broken Gothic Elliptical Flat Top



Tudor Double Trifoil Octagonal Dogear

Note: The settings on the Shape tab take precedence over those on the Arch tab. If the window's Shape has been modified, you can select an Arch but it will have no effect on the window's appearance.

- Specify the **Height** of the arch, as measured from the base of the arch to the top of the window. The height can be defined for all arch types except Round Top and Octagonal Arches.
- The **Radius** can also be defined for Tudor and Double Arches.
- ② **Options** - Define the orientation of the arch.
- Check **Reflect** to reflect the arch, top to bottom. You can reflect a window with a Round Top arch to create a round window. Not available if a lintel is specified

for the selected window. See “Lintel & Sill Tab” on page 299.

- Select **Full Arch** to produce an arch with the apex at the window's center.
- Select **Arch on Left** to produce an arch with the apex on the window's right side.
- Select **Arch on Right** to produce an arch with the apex on the window's left side.
- ③ A preview of the selected window displays here.
- Check **Show Color** to show the window preview in color.
- Select **Interior** or **Exterior** to specify which side of the window displays in the preview. This can significantly affect a shaped window's appearance in the preview, as the Left and Right Side settings refer to the side of the window shown in the preview.

Treatments Tab

The settings on the Treatments tab allow you to assign embellishments to the interior and

exterior of the selected window or mullied unit.

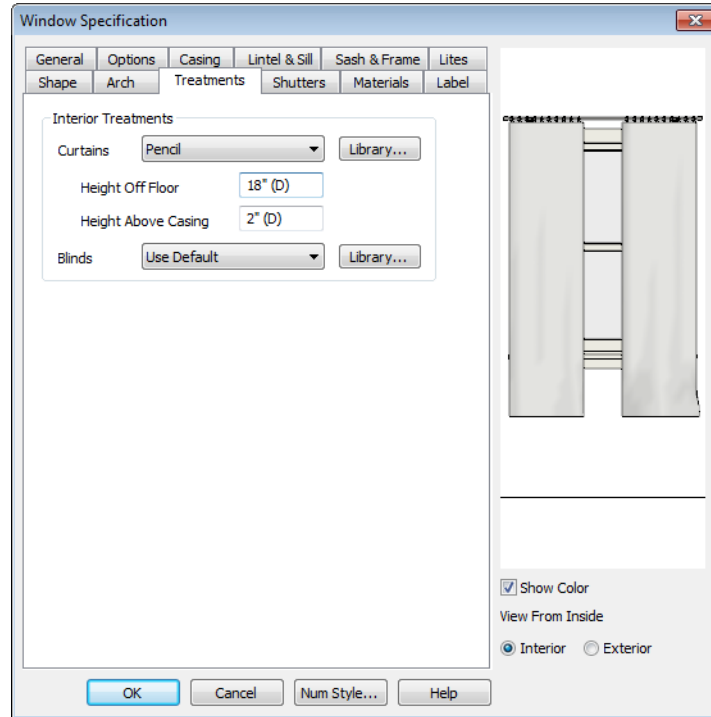

Specify **Interior Treatments** for the selected window or mullied unit.

- Specify a style of **Curtains** by selecting “Use Default”, “None” or “Library” from the drop-down list. If a non-default library item has been selected, its name will display in the list, as well.
- Click the **Library** button or select “Library” from the Curtains drop-down list to choose a style of curtain from the library. See “Select Library Object Dialog” on page 622.
- Specify the **Height Off Floor** of the bottom edge of the curtains.

- Specify the **Height Above Casing** of the top of curtains.
- Specify a style of **Blinds** in the same manner that Curtains are chosen, above.

A preview of the selected window displays on the right.

- Check **Show Color** to show the window preview in color.
- Select **Interior** or **Exterior** to specify which side of the window displays in the preview. In order to see interior treatments in the preview, Interior must be selected.

Shutters Tab

The settings on the Shutters tab allow you to specify exterior shutters for the selected window or mullied unit.

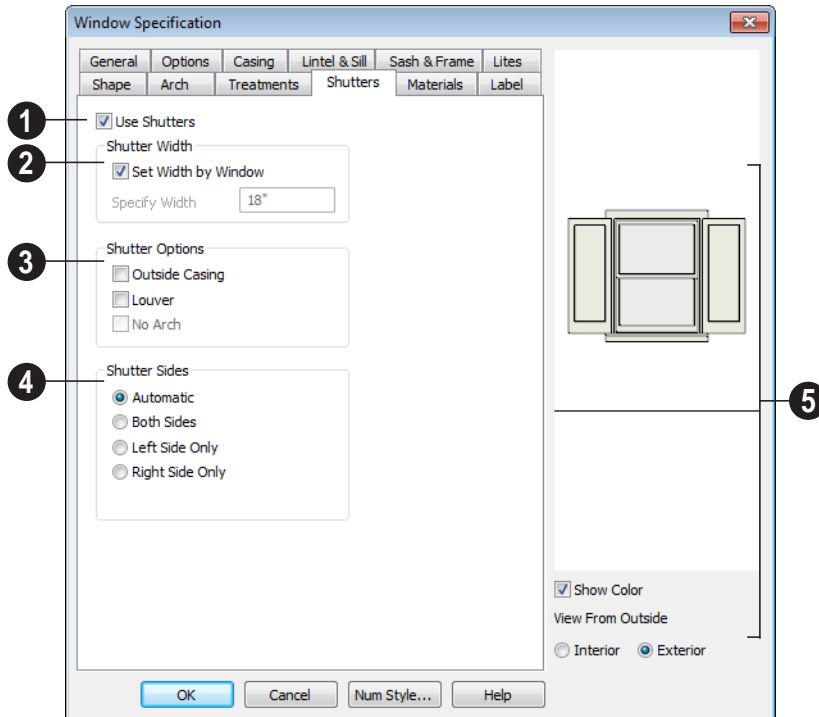

1 Check **Use Shutters** to apply shutters to the selected window's exterior and enable the settings below.

2 Specify the **Shutter Width** for the selected window.

- Uncheck **Set Width by Window** to type a width in the **Specify Width** field. If the window is later resized, the shutters width will not adjust in response.
- When **Set Width by Window** is checked, a shutter width exactly half that of the window, excluding casing, is used.

3 Additional **Shutter Options** can be specified here.

- Check **Outside Casing** to position shutters outside the window casing, as decorative shutters often are. Uncheck this to position the shutters just outside the window frame, like functional shutters.
- Check **Louver** for louvered shutters. Uncheck this for solid shutters. If **Outside Casing** is checked, the louvers face outward, away from the wall; if checked, louvers face toward the wall.

- Check **No Arch** for shutters with flat tops that reach the bottom of the curved portion of an arched window. Only available when an Arch is selected. See “Arch Tab” on page 306.
- 4** **Shutter Sides** - Specify which sides of the selected window receive shutters.
- Select **Automatic** to assign shutters to both sides of the window as long as there is sufficient room on the wall. If the window is next to a wall intersection or corner, the shutter closest to the intersection will not generate.
 - Select **Both Sides** to assign shutters to both sides of the window under all circumstances, even if there isn’t enough room on the wall for one or both of them.
 - Select **Left Side Only** to assign a shutter to the left side of the window and none on the right.
 - Select **Right Side Only** to assign a shutter to the right side of the window and none on the left.
- 5** A preview of the selected window displays on the right.
- Check **Show Color** to show the window preview in color.
 - Select **Interior** or **Exterior** to specify which side of the window displays in the preview. In order to see exterior shutters in the preview, Exterior must be selected.

Materials Tab

The settings on the Materials tab are the same as those found on the same tab in dialogs throughout the program. See “Materials Tab” on page 635.

The settings on the Materials tab of the **Mulled Unit Specification** dialog apply to all components of the blocked unit. Any settings made for individual components of the blocked unit are overridden here.

Label Tab

Window labels display in floor plan view when the “Windows, Labels” layer is turned on and use the Text Style assigned to that layer. See “Window Labels” on page 288.

For more information about the settings on this tab. See “Label Tab” on page 885.

Bay/Box Window Specification Dialog



To open the **Bay/Box Window Specification** dialog, select one or more bay or box windows and click the **Open Object** edit button.

The options in this dialog can only be set for objects placed in a plan: bay or box windows do not have defaults dialogs. Many of these same options are available for Bow windows. See “Bow Window Specification” on page 313.

General Tab

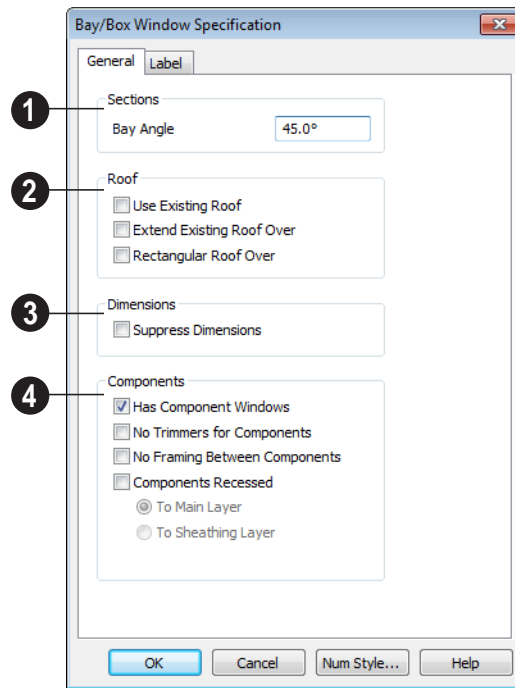

1 Specify the **Bay Angle**, which is the angle of the side components of the bay or bow window. Bay windows have an angle of 45° by default; box windows have an angle of 90°.

2 Specify the structure of the automatic **Roof** over the selected window unit. See “Bay, Box, Bow Windows & Roofs” on page 292.

- Check **Use Existing Roof** if the existing roof needs no changes to accommodate the bay window.
- Check **Extend Existing Roof Over** to extend the existing roof plane to cover the bay window below.

- Check **Rectangular Roof Over** to create a roof over the bay window that is square across the end instead of following the profile of the roof.

3 Specify the appearance of the selected window unit’s **Labels** in floor plan view and the Materials List.

- Check **Suppress Dimension** to suppress the automatically-produced dimensions that show the size of the window unit in floor plan view.

4 Specify the structure of the selected window unit’s **Components** and the wall sections containing them.

- Uncheck **Has Component Windows** to remove the component windows of the

bay or box window unit and disable the settings that follow.

By default, Bay and Box Windows have one standard trimmer when first created.

- Check **No Trimmers for Components** to eliminate the trimmer stud for bay components, allowing the component window width to increase. See “Wall Framing” on page 436.
- Check **No Framing Between Components** to remove both studs between the bay components.

If the selected unit is later moved or resized, its components automatically resize to use a standard trimmer, regardless of whether either of the two options above are selected.

- Check **Components Recessed** to recess the exterior casing into the wall. Typically used if the window is placed in a

brick wall and you want to produce a brick molding. When checked, the options below become available.

- Select **To Main Layer** to recess the components to the wall’s Main Layer instead of the outside wall layer. See “The Main Layer” on page 209.
- Select **To Sheathing Layer** to recess the components to the sheathing layer instead of the outside wall layer.



Label Tab

Bay and Box Window labels display in floor plan view when the “Windows, Labels” layer is turned on and use the Text Style assigned to that layer. See “Window Labels” on page 288.

For more information about the settings on this tab. See “Label Tab” on page 885.

Bow Window Specification



To open the **Bow Window Specification** dialog, select one or more Bow Windows and click the **Open Object** edit button or double-click on a Bow Window using the **Select Objects**  or a **Window**  tool.

Many of the options in this dialog are the same as the **Bay/Bow Window Specification**. See “Bay/Box Window Specification Dialog” on page 311.

General Tab

Four options are unique to the **Bow Window Specification** dialog:

- 1 Specify the **Number of Sections**, or components, in the window unit.
- 2 Check **Suppress Standard Dimension** to suppress the automatically produced
- 3 Check **Suppress Dimension to Center** to suppress the radial dimension.
- 4 Check **Connect Outer Casing** to have the exterior casing surround all three

dimensions that show the width and depth of the bow in floor plan view.

bay component windows together, not separately. Mullions are provided between components. This is how casing is always done for the interior.

Label Tab

Bow Window labels display in floor plan view when the “Windows, Labels” layer is

turned on and use the Text Style assigned to that layer. See “Window Labels” on page 288.

For more information about the settings on this tab. See “Label Tab” on page 885.

Multiple Floors

When a new plan file is opened in Home Designer Pro, two floor levels are present: Floor 1 and the Attic Floor. You can add more floors whenever you like: up to 3 total. Once created, floors can also be copied and deleted.

Home Designer Pro also supports special floors for foundations and attics. Only one foundation level and one attic can exist in a plan. Foundations are discussed in their own chapter. See “Foundations” on page 329.



Chapter Contents

- Floor Defaults Dialog
- Floor Tools
- Adding Floors
- Displaying Floors
- Deleting Floors
- Floor and Ceiling Platforms
- Floor and Ceiling Platform Definitions
- Copying Floors
- Rebuilding Walls, Floors & Ceilings
- Split Levels
- The Current Floor
- The Attic Floor
- The Reference Floor

Floor Defaults Dialog



There is a **Floor Defaults** dialog for each floor in a plan file. The defaults for the current floor can be accessed by selecting **Edit> Default Settings**. Select “Floor” from the category tree and click the **Edit** button to open the **Floor Defaults** dialog for the currently active floor. See “Default Settings vs Preferences” on page 56.

- The **Floor Defaults** dialog can also be opened by double-clicking the **Floor Tools**  parent button.
- In addition, the **Floor Defaults**  button can be added to a toolbar for quick access to the **Floor Defaults** dialog. See “Toolbar Customization Dialog” on page 93.

The **Floor Defaults** dialog also opens whenever you add a new floor to the plan. See “Adding Floors” on page 317.

The **Floor Defaults** dialog does not open when you build a foundation; however, the **Floor 0 Default** settings are created based on the current Foundation Defaults. See “Foundation Defaults” on page 330.

The **Floor Defaults** dialog is similar to the **Room Specification** dialog, but controls the default settings for all rooms on the current floor. The settings here also control the height of individual walls as they are drawn on the floor in question. See “Room Specification Dialog” on page 244.

Note: The default floor height for Floor 1 is 0. It can be modified in the Room Specification dialog, but not in the Floor 1 Defaults dialog. See “Floor and Room Defaults” on page 230.

General Tab

Only one setting on the General tab is unique to the **Floor Defaults** dialog.

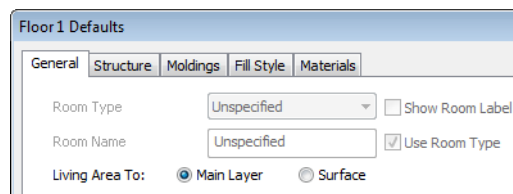

On Floor 1 only, define the wall layer that you would like to calculate the **Living Area To**. See “Living Area” on page 237.

Structure Tab

The settings on the Structure tab are similar to those in the **Room Specification** dialog. See “Structure Tab” on page 245.

Moldings Tab

The settings on the Moldings tab are similar to those in the **Room Specification** dialog. See “Moldings Tab” on page 250.

Fill Style Tab

The settings on the Fill Style tab are similar to those in the specification dialogs for many

objects throughout the program. See “Fill Style Tab” on page 792.

Materials Tab

The settings on the Materials tab are similar to those in the specification dialogs for many objects throughout the program. See “Materials Tab” on page 635.

Floor Tools



Select **Build> Floor** to access the floor tools.



Select **Build> Floor> Build New Floor** to build a new floor. A new floor can be generated based upon the perimeter of the floor below or a blank floor can be created and drawn from scratch. See “Adding Floors” on page 317.



Select **Build> Floor> Insert New Floor** to insert a new floor below the current floor. See “Adding Floors” on page 317.



Choose **Build> Floor> Delete Current Floor** to remove the current floor from the plan. For more information, see “Deleting Floors” on page 320.



Choose **Build> Floor> Build Foundation** to open the **Foundation Defaults** dialog and build a foundation floor. See “Building a Foundation” on page 334.



Select **Build> Floor> Delete Foundation** to remove the foundation from the plan. See “Deleting Foundations” on page 338.



Choose **Build> Floor> Rebuild Walls/Floors/Ceilings** to force Home Designer Pro to recalculate the relationship between the walls, floors, and ceilings in your model. See “Rebuilding Walls, Floors & Ceilings” on page 324.



Select **Build> Floor> Rebuild Slabs** to force the rebuild of any slabs in the plan.

Adding Floors

New floors can be added in floor plan view and 3D views.

To create a new floor

1. Select **Build> Floor> Build New Floor**  to open the **New Floor** dialog.

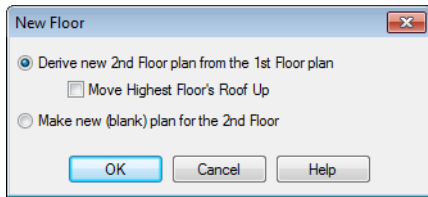

2. Select the options that you need and click **OK**.
 - **Derive new 2nd floor plan from the 1st floor plan** creates a new top floor with exterior walls generated directly over the exterior walls of the floor below. Wall types and roof directives associated with the walls on the floor below are duplicated; however, interior walls are not. See “Roof Tab” on page 218.
 - Check **Move Highest Floor’s Roof Up** to move any roof planes displaying on the highest floor in the plan up one floor when the new floor is created. Roof planes displaying on floors other than the top floor are unaffected. This option is only available if there are roof planes built on the top floor and is not available when **Auto Rebuild Roofs** is enabled. See “Build Roof Dialog” on page 355.

 When Move highest floor roof up is checked, roof planes on the top floor will move even if the “Roof Planes” layer is locked and manually edited roof planes are set to be retained. See “Roof Tab” on page 356.

- **Make new (blank) plan for the 2nd floor** creates a new top floor that is blank. This option is typically selected only if none of the exterior walls on the

new floor will be directly above the exterior walls on the floor below. If you choose this method, it may be helpful to turn on the Reference Display when drawing walls on the new floor. See “The Reference Floor” on page 327.

3. The **Floor Defaults** dialog for the newly created floor opens next. Make any necessary changes to the floor structure, moldings, or materials and click OK. See “Floor Defaults Dialog” on page 316.
4. The new floor becomes the current floor in floor plan view. If, however, the new floor is created in a 3D view, the camera remains on its original floor and does not move.

Note: Home Designer Pro allows only one floor, the foundation/basement, below the first floor. Keep this in mind when you begin an as-built or plan for a multi-story building.

Inserting Floors

A floor can be inserted beneath the current floor in both floor plan view and 3D views.

If you are in a 3D view, begin by selecting **Tools> Reference Floors> Change Floor/Reference**  and select the floor you would like to insert a floor under as the Current Floor. See “Change Floor / Reference” on page 328.

To insert a floor

1. Select **Build> Floor> Insert New Floor** . The **Insert Floor** dialog opens.

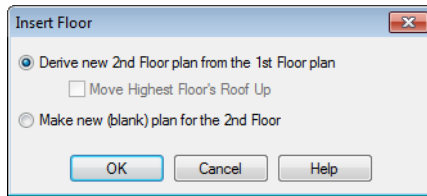

2. Select one of the two available options:
 - Select **Derive new 2nd Floor plan from the 1st Floor plan** to insert a new floor below the current floor, based on the exterior walls of the current floor.

- Select **Make new (blank) plan** to insert a blank floor below the current floor.
3. Click **OK**. The existing floor and any floors above it are moved up, and a new floor is created below.

Adding a Foundation

To add a foundation, select **Build> Floor> Build Foundation** . See “Building a Foundation” on page 334.

Displaying Floors

Home Designer Pro allows you to view the floors in your plan in a variety of ways.

In Floor Plan View





In floor plan view, only one floor can be active for editing at a time. This is referred to as the Current Floor. See “The Current Floor” on page 326.

In addition to the Current Floor, one other floor can be displayed for reference purposes: the Reference Floor. Objects on the Current Floor can snap to those on the Reference Floor, helping you align objects. See “The Reference Floor” on page 327.

Floor and ceiling platforms do not display in floor plan view. When floor and/or ceiling framing is present, its display can be turned on; however, other components of floor and ceiling platforms like sheathing, drywall, and finish materials, cannot.

In 3D Views

In most 3D views, all floors in a plan are visible, from the foundation up to the attic. There are three exceptions:

- **Perspective Floor Camera**  views.
- **Orthographic**  and **Perspective Doll House Views** .
- **Wall Elevation**  views.

Floor Cameras and **Doll House Views** show the Current Floor only, not including its ceiling, while the **Wall Elevation** tool creates an elevation of a wall on a single floor in a single room. See “3D View Tools” on page 672.

In the Materials List

The materials that make up floor and ceiling platform assemblies are listed under different Categories in the Materials List:



- **Subfloor** - Lists floor framing and structural subflooring materials specified in all Floor Structure Definitions in the current plan. See “Floor and Ceiling Platform Definitions” on page 322.
 - **Flooring** - Lists flooring and subflooring materials specified in all Floor Finish Definitions in the current plan.
 - **Framing** - Lists ceiling framing and any other materials specified in all Ceiling Structure Definitions in the current plan.
 - **Wall Board** - Lists ceiling finish materials specified in all Ceiling Finish Definitions in the current plan.
 - **Insulation** - Floor insulation is calculated for all rooms that have a floor, and ceiling insulation is calculated for all rooms that have a ceiling - regardless of the Floor or Ceiling Structure Definition. When a ceiling is not present, insulation is calculated for the roof. See “Structure Tab” on page 245.
 - **Foundation** - Lists the concrete and mesh for all Floor Structure Definitions in the current plan with a layer of concrete material. See “Material Types” on page 640.
- See “Materials Lists” on page 887.

Copying Floors

The **Edit Area**  tools can be used to make copies of entire floors in a plan. See “Edit Area Tools” on page 168. You can use these tools to:

- Make a copy of an existing floor to be pasted onto a new floor.
- Make a copy of all existing floors in a plan to be pasted into a different plan.

You can also copy the information on a floor by pressing Ctrl + A (Select All), then using

Copy  and **Paste Hold Position** . See “Paste Hold Position” on page 117.

Copying Between Plans

While you can copy and paste floors from one plan file to another, this is not always the best approach.

- To make a copy of the plan for backup or your records, use **Save As**  to save the file using a new name. See “Saving, Exporting, and Backing Up Files” on page 43.
- To copy the model into another plan with multiple structures, consider exporting it as a symbol and importing it into the new plan. See “Custom Symbols” on page 43.

Deleting Floors

 Select **Build> Floor> Delete Current Floor** to remove the current floor from the plan. If there is a floor above, it becomes the current floor; if there is no floor

below, the floor beneath becomes the current floor.

 To delete Floor 0, select **Build> Floor> Delete Foundation**. You can

delete the foundation without actually being on Floor 0. Floor 0 cannot be deleted while **Auto Rebuild Foundation** is turned on. See “Deleting Foundations” on page 338.



When a floor is deleted, all objects on that floor are deleted with it, including locked roof planes and any other objects on locked layers. See “Locking Layers” on page 103.

Floor and Ceiling Platforms

In many ways, floors in Home Designer Pro are defined by the floor platforms below them and the floor and/or ceiling platforms above.

You can specify the thickness and framing materials used to construct floor and ceiling platforms on a floor-by-floor basis in the **Framing Defaults** dialog. See “Floor Tabs” on page 443.

You can also specify the floor and ceiling structures of individual rooms in the **Room Specification** dialog. See “Structure Tab” on page 245.

Floor vs Ceiling Platforms

Floor and ceiling platforms are not the same thing in Home Designer Pro. Floor platforms have living space above them and are designed to be weight-bearing. Ceiling platforms, on the other hand, have living space below them but not above them. They are not designed to bear weight and are typically less strong - and less thick - than floor platforms.

Stepped Floor & Ceiling Platforms

Each floor has default floor and ceiling heights. You can, however, use the **Room**

Specification dialog to specify floor and ceiling heights on a room by room basis to create stepped floors and ceilings. See “Structure Tab” on page 245.

If you require a single floor platform with a uniform height and thickness but different ceiling heights for the rooms below, specify a lowered ceiling using the **Ceiling Finish Specification** dialog. See “Lowered Ceilings” on page 241.

By default, the gap between floor and ceiling platforms that step at a railing or invisible wall is closed off by a short section of solid wall. If you require a gap between the platforms, uncheck **Generate Between Platforms** in the **Wall** or **Railing Specification** dialog. See “General Tab” on page 214.

Cantilever Undersides

If a room cantilevers out past an exterior wall, the cantilever will use the floor platform of the room above it. You can specify the surface material of the underside of a cantilever on the Materials tab of the **Room Specification** dialog. For no material, select “No Material” from the **Plan Materials** dialog. See “Room Specification Dialog” on page 244.

Platform Edges

Typically, floor and ceiling platforms are built so that they bear on top of walls. The edges of the platform structures extend through exterior walls to the layer of the wall type definition with the **Build Platform to This Line** setting. See “Wall Type Definitions” on page 209.

- For framed walls, the **Build Platform to This Line** layer is set as the outside of the wall’s Main Layer,
- For concrete walls, it’s the inside of the wall’s Main Layer.

- The platforms of rooms with raised floors and/or lowered ceilings build in the same manner: to the **Build Platform to This Line** layer of the wall type assigned to the railing or invisible wall defining the room. See “Floor & Ceiling Heights” on page 239.

For a given wall type, you can specify a different **Build Platform to This Line** wall layer surface provided that it is on the exterior side of the Main Layer.

In addition, you can specify that individual walls build through floor and ceiling platforms in the **Wall Specification** dialog. See “General Tab” on page 214.

Floor and Ceiling Platform Definitions

Floor and ceiling platforms are made up of layers of different materials such as framing, subflooring, drywall, and finish materials. You can specify the composition of floor and/or ceiling platforms on a floor-by-floor and also a room-by-room basis. You can specify how these platforms are constructed in the **Floor** and **Ceiling Structure Definition** dialogs.

- To specify the composition of the floor and ceiling platforms for an entire floor: open the Structure tab of the **Floor Defaults** dialog and click the **Floor Structure** or **Ceiling Structure** button.
- To specify the floor and/or ceiling structure for an individual room, open the Structure tab of its **Room Specification** dialog and click the **Floor Structure** or

Ceiling Structure button. See “Structure Tab” on page 245.

In addition to the structural layers of a platform, floors and ceilings also have a finish layer. You can specify floor and ceiling finish materials for an entire floor or individual room on the Materials tab of either the **Floor Defaults** or **Room Specification** dialog. See “Materials Tab” on page 635.

Floor and ceiling platform definitions play a role in determining floor and ceiling heights. Floor and ceiling finishes can be used to create dropped ceilings. See “Floor & Ceiling Heights” on page 239.

All floor and ceiling materials are used for the calculation of the materials list.

Floor/Ceiling Structure Definition Dialog

The settings in the **Floor** and **Ceiling Structure Definition** dialogs are similar to one another. They are also similar to the

settings found in the **Floor Finish Definition** dialog.

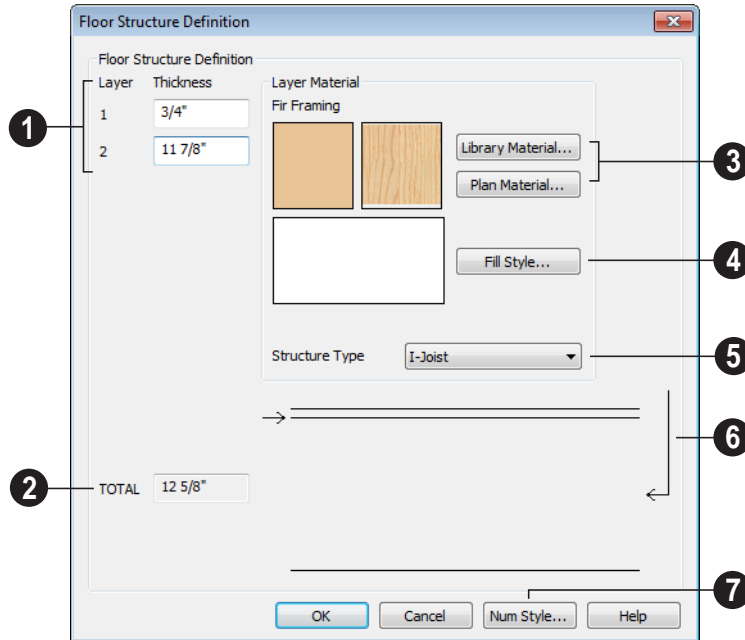

1 The layers of the floor or ceiling platform structure definition are listed here. Layers are numbered and listed from the top of the structure to its bottom.

To select a layer for editing, click in its Layer Thickness text field. The arrow to the right of the structure diagram points to the selected layer, while the arrow to the left of the diagram points to its top surface.

Define the **Thickness** for each structural layer by typing in the text field. The layer thickness format can be changed by clicking the Num Style button.

 You can also select a layer by clicking on it in the structure diagram at the bottom right of the dialog.

2 The **Total** thickness of the structure definition displays here as a reference.

3 Specify the **Layer Material** of the selected structural layer.

- Click the **Library Material** button to open the **Select Library Object** dialog. See “Select Library Object Dialog” on page 622.

- Click the **Plan Materials** button to open the **Plan Materials** dialog. See “Plan Materials Dialog” on page 642 .

Previews of the selected material’s pattern and texture display in the boxes to the left of the **Library** and **Plan Materials** buttons.

- 4 Click the **Fill Style** button to open the **Layer Fill Style** dialog and specify a fill style for the selected wall layer. This dialog is similar to the Fill Style tab for CAD objects. See “Fill Style Tab” on page 792.

A preview of the selected layer’s fill style displays to the left of the **Fill Style** button.

- 5 Click the **Structure Type** drop-down and select the type of framing member used for the platform structure. Only available when the selected material is a Framing type. See “Framing Member Types” on page 463.

- 6 The arrow to the right of the structure diagram points to the selected layer. To select a layer, click on a layer in the diagram or click in its **Thickness** field.

The arrow to the left of the structure diagram points to the selected layer’s surface.

- 7 Click the **Num Style** button to open the **Number Style/Angle Style** dialog. Here you can change the numbering format

used in dialogs like this one. See “Number Style/Angle Style Dialog” on page 89.

Ceiling Finish Dialog

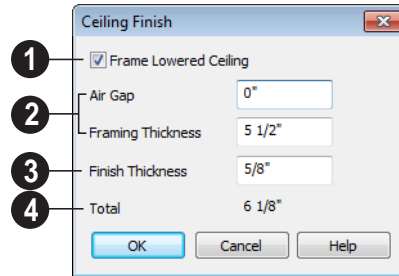

- 1 Check **Frame Lowered Ceiling** to enable the two settings that follow.
- 2 These settings are only available when **Frame Lowered Ceiling** is checked.
 - Specify the **Air Gap**, which is the vertical distance between the lowered ceiling framing and the framing of the platform above it.
 - Specify the **Framing Thickness**, which is the vertical depth of the framing of the lowered ceiling.
- 3 Specify the **Finish Thickness**, which is the vertical depth of the ceiling finish material.
- 4 The **Total** thickness of the structure definition displays here for reference.

Rebuilding Walls, Floors & Ceilings



When you make a change to the walls or to the floor or ceiling platforms in your plan, they may not immediately resize or move in the 3D model. The program does detect such changes, though, and the next

time you generate a 3D or section/elevation view, walls, floors and ceilings are rebuilt.

By default, walls, floors and ceilings are also rebuilt when an automatic roof is generated. See “Build Roof Dialog” on page 355.

You can direct the program to rebuild walls, floors and ceilings at any time by selecting **Build> Floor> Rebuild Walls/Floors/**

Ceilings  or by pressing the F12 key.

If you do not want the program to rebuild walls, floors and ceilings when a 3D view is created, uncheck **Auto Rebuild Floors &**

Ceilings in the **3D View Defaults** dialog.

This may speed up plan view editing for very large plans. When this is unchecked and the structure is not up to date, the Rebuild Walls, Floors, Ceilings  icon displays near your mouse pointer. See “Options Tab” on page 669.

Split Levels

Both split level floor plans and split level entries can be created by controlling the floor and ceiling heights of individual rooms in a multiple story structure.

Split Level Floor Plans

A split level, or tri-level, structure is a building where the floor level in one part of the plan is located approximately half way between the floor and ceiling levels of another part of the plan.



Split Level Home

To create a simple split level plan

1. Draw a simple rectangular structure divided into two separate halves by an interior wall.
2. Select one of the rooms and click the **Open Object**  edit button. See

“Room Specification Dialog” on page 244.

3. Raise the **Floor Height** then press the Tab key.
4. Restore the **Relative Rough Ceiling** to the default value, then click OK.
5. Build a stem wall foundation. See “Foundations” on page 329.
 - The foundation under the room with the lower floor height will have the specified Min Stem Wall Height.
 - The foundation under the room with the raised floor will have taller stem walls.
 - Both can be edited in the **Room Specification** dialog.
6. If you add a Floor 2, note that the **Ceiling Height** in the room on Floor 1 will be reset to the default value.
 - To maintain a stepped condition on multiple floors, return to this room and set the **Relative Rough Ceiling** back to using the default.

For more detailed instructions, visit www.HomeDesignerSoftware.com.



Split Level Entries

A split level entry, or divided entry, is characterized by an entry door that opens onto a landing positioned half way between the basement floor and first floor levels.



Split Level Entry

To create a simple split level entry

1. Create a plan file with a full basement at the location of the entry door. See “Basement Rooms” on page 339.
2. Go to Floor 0 and draw a stair **Landing**  at the location of the entry. See “Landings” on page 406.
3. Specify the desired height of the landing. See “Stair Landing Specification Dialog” on page 433.
4. Draw stairs upward from the basement floor to the landing.
5. Draw a second stair section from the landing upward.
6. Select the stairs and click the **Auto Stairwell**  edit button. See “Creating a Stairwell” on page 419.

Split level entries are often associated with daylight basements. See “Daylight Basements” on page 340.

For more detailed instructions, visit www.HomeDesignerSoftware.com.

The Current Floor

Only one floor can be active at any given time. The active floor is referred to as the **Current Floor**, and it is the only floor on which objects can be edited.

If you want to edit two different floors at the same time, you can open the plan again. This opens a second window on the current open plan that has the same editing abilities as the first. Only one of these windows can be active at any given time.

Floor Up / Floor Down



If you are working with more than one floor, you can select **Tools> Reference Floors> Up**

One Floor or **Down One Floor** to switch from one floor to another.

You can change the current floor in floor plan, cross section/elevation and 3D views.

The current floor displays on the **Change Floor/Reference**  button, which can be found between the **Down One Floor** and the **Up One Floor** buttons.

Floors become available once they have been built. The Attic and foundation levels are also accessible using these tools.

Change Floor / Reference



If there are multiple floors, select **Tools> Reference Floors> Change**

Floor/Reference to open the **Change Floor/Reference** dialog, where you can select both the current floor and which floor is used in

the Reference Display, as well as control the appearance of the Reference Display.

The Attic Floor



Home Designer Pro automatically creates a floor above the top numbered floor level of each plan. This floor is called the Attic floor and has only one purpose: to provide a space for automatically generated Attic walls. See “Attic Walls” on page 206.

Because the Attic floor is not meant to be a living area, a warning message will display if

you try to draw walls or other objects on this floor.

In some situations, you may find it necessary to draw one or more walls on this floor; however, even if you enclose an area with walls, rooms cannot be created on the Attic floor.

If you wish to create an attic loft, bonus room, or storage area in your plan, you will need do so on a numbered floor level.

The Reference Floor

When there is more than one floor in a model, it is often helpful to see how different floors relate to each other. Any floor can be shown as the **Reference Floor** along with the current floor.

When the Reference Display is turned on, the floor that you were last on prior to the current floor is used as the Reference Floor. Objects on the current floor can snap to objects on the Reference Floor; however, objects on the Reference Floor cannot be selected or edited.

Reference Display



To display the Reference Floor, select **Tools> Reference Floors> Reference Display** or press F9 on your keyboard. The reference floor can also be toggled on or off

quickly in floor plan view by clicking the **Reference Display** toggle button on the utility toolbar.

If the Reference Display is on when a floor plan view is sent to layout, the Reference Display is always on in that layout view and cannot be turned off.

If the Reference Display is turned on when a view is printed, it will be included in the printed output. See “Display Options and Printing” on page 844.

Note: If objects on the current floor and the Reference Floor have edges that line up, the Reference Floor may be difficult to see on screen. When lines of two different colors are superimposed upon each other, discoloration may result.

Reference Display Options



The display of objects in the Reference Display is controlled by selecting **Tools> Reference Floors> Reference Display Options**. See “Layer Display Options Dialog” on page 104.

Change Floor / Reference



By default, the floor below the current floor is the Reference Floor, but any floor can be referenced using the **Change Floor/Reference** dialog. To open the dialog, select **Tools> Reference Floors> Change Floor/Reference** button.

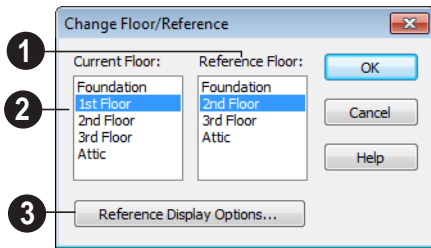

1 The **Reference Floor** currently used for reference is highlighted here. You can select another floor.

2 The **Current Floor** is highlighted here. You can select another floor to make it the current floor.

3 Click the **Reference Display Options** button to open the **Layer Display Options** dialog and change the settings for the reference display. See “Layer Sets” on page 103.

Swap Floor/Reference



If one floor is defined as the current floor and another floor is defined as the reference floor, select **Tools> Reference Floors> Swap Floor/Reference** to switch the status of the two floors.

Foundations

There are three foundation types in Home Designer Pro: stem walls with footings, walls with piers and monolithic slab. All three can be generated automatically or manually. The foundation type can be specified in the **Foundation Defaults** dialog when the foundation is built.

There can be only one foundation level in your plan, Level 0. Foundation walls can be drawn on upper floors using the **Foundation Wall** and Slab tools.



Always consult registered geotechnical and civil engineers for information regarding the proper foundation for your site.

Chapter Contents

- Foundation Defaults
- Building a Foundation
- Displaying Foundations
- Editing Foundations
- Aligning Foundation Walls
- Deleting Foundations
- Foundations and Rooms
- Foundations and the Terrain
- The Slab Tools
- Editing Slabs
- Editing Piers and Pads
- Slab Specification Dialog
- Fireplaces
- Fireplace Specification Dialog
- Library Fireplaces
- Chimneys

Foundation Defaults



There are several defaults dialogs that affect the foundation. They can be accessed by selecting **Edit > Foundation Defaults Settings**.

Select “Foundation” and click the **Edit** button to open the **Foundation Defaults** dialog.

If a foundation has been built and you are on Floor 0, select “Floor” and click the **Edit** button to open the **Floor 0 Defaults** dialog.

The settings here are initially drawn from those in the **Foundation Defaults** dialog. See “Floor Defaults Dialog” on page 316.

Click the + beside “Walls” to display the subheadings, then select “Foundation Wall” and click the **Edit** button to open the defaults dialog for the Foundation Wall tool. See “Wall, Railing, and Fencing Defaults” on page 176.

Foundation Defaults Dialog

The **Foundation Defaults** dialog allows you to specify stem wall height, slab thickness, treated sill plates, and other characteristics of a foundation. These values determine how a new foundation is generated as well as the sizes for manually drawn foundation walls added to an existing foundation.

The settings in the **Foundation Defaults** dialog are similar to those in the **Build Foundation** dialog, which opens when

Build > Floor > Build Foundation  is selected. The primary difference is that when you click **OK** in the **Foundation Defaults** dialog, no changes are made to the model. See “Building a Foundation” on page 334.

Foundation Tab

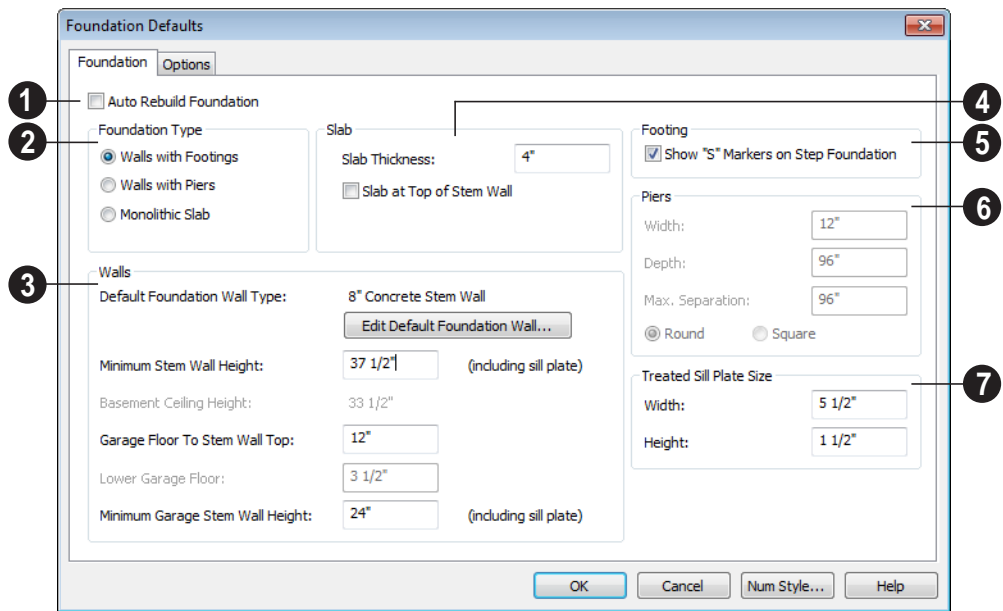

- 1 Check **Auto Rebuild Foundation** to automatically rebuild the foundation whenever changes are made to Floor 1 that affect the structure of the foundation. See “Rebuilding Foundations” on page 336.
 - 2 Three different **Foundation Types** can be created in Home Designer Pro. Select the radio button next to the desired type.
 - Select **Walls with Footings** to produce a foundation composed of stem walls with footings that run continuously under the base of the walls.
 - Select **Walls with Piers** to generate a pier and grade beam foundation. The floor framing rests directly on top of the grade beam.
 - 3 The **Walls** settings affect the generation of all three Foundation Types.
 - The name of the **Default Foundation Wall Type** displays here for reference.
 - Click the **Edit Default Foundation Wall** button to open the **Foundation Wall Defaults** dialog and change the default settings for foundation walls. See “Foundation Walls” on page 183.
 - If Monolithic Slab is the selected Foundation Type, the **Edit Garage Curb** but-
- Select **Monolithic Slab** to build a slab foundation defined by slab footings. The foundation forms the floor platform for Floor 1. It is visible on Floor 0 and can be selected and edited.
- Each type of foundation has different default settings, options, and behaviors.

ton will be available. Click it to open the **Foundation Wall Defaults** dialog and define the walls that form curbs around Garage and Slab rooms.

- Specify the **Minimum Stem Wall Height**, which is the minimum height for foundation walls and grade beams and includes the treated sill plate.
- The **Basement Ceiling Height** displays here as a reference. This is the distance from the top of the slab floor to the basement ceiling and is equal to the Minimum Wall Height minus the Slab Thickness.

If the Minimum Wall Height is at least 76" (1900 mm), a Ceiling Finish is added to the foundation room automatically. A slab floor is also generated above the footing. The ceiling height and finish can be changed later. See "Room Specification Dialog" on page 244. To remove this slab, specify the room areas in the basement as "Open Below". See "Room Types" on page 234.

- Specify the **Garage Floor to Stem Wall Top**, which is the distance between the slab and the tops of the stem walls in both Garage and Slab rooms. Available for Walls with Footings and Walls with Piers foundation types. See "Foundation Defaults" on page 330.

Note: The Garage Floor to Stem Wall Top setting only affects Garage rooms that have a Floor Height of 0. See "Structure Tab" on page 245.

- Specify the **Lower Garage Floor** height, which is the distance that Garage and Slab room floors are lowered when a

Monolithic Slab foundation is built. This value is also the height of the curbs around these rooms. See "Garages" on page 338.

- Specify the **Minimum Garage Stem Wall Height**, which is the minimum height that stem walls defining a Garage foundation will be, regardless of the Minimum Stem Wall Height for the rest of the foundation.

4 Slab

- Specify the **Slab Thickness**, which is the thickness of the slab produced above the footing or at the top of the stem wall.
- Check **Slab at top of Stem Wall** to raise the slab so its top is flush with the top of the stem walls. Only available when Walls with Footings is the selected Foundation Type.

If **Slab at top of Stem Wall** is selected, all rooms on the first floor are automatically set to **Floor Supplied by the Foundation Room Below** in the **Room Specification** dialog. See "Structure Tab" on page 245.

- Check **Show "S" Markers on Step Foundation** to include an "S" symbol in floor plan view anywhere there is a step in foundation wall height. See "Displaying Foundations" on page 335.

- The **Piers** options are only available when Walls with Piers is the selected Foundation Type.

- Specify the **Width, Depth, and Maximum Separation** of the piers.
- Choose either **Round or Square** piers.

7 Treated Sill Plate Size - Enter a **Width** and **Height** for the treated sill plate, also referred to as a mudsill. If the Height is set to zero, no sill plate is produced. A sill plate is only produced if the Main Layer of

the wall above is a framing type. Not available if **Monolithic Slab** is the selected **Foundation Type**. See “Treated Sill Plates” on page 437.

Options Tab

The Options tab allows you to include rebar and other materials related to the foundation in the Materials List. See “Materials Lists” on page 887.

Some options on this tab may be unavailable depending on the foundation type selected on the Foundation tab.

	#bars/course	Course Spacing	Bar Size	Overlap	
Rebar					
Footing	2		No. 4	40.0	Diameters
Wall Horizontal	2	12"	No. 4	40.0	Diameters
Wall Vertical	2	24"	No. 4	0.0	Diameters
Pier	4		No. 4	0.0	Diameters
Slab	0	12"	No. 4	40.0	Diameters

Use Mesh

Foundation Options

Foam Seal

Termite Flashing

1 # bars/course - Specify the number of rebar in the **Footing**, the number of **Horizontal** and **Vertical** rebar courses in the stem walls, and the number of rebar layers in the **Slab**. If piers are used, specify how many rebar are used per **Pier**. Rebar does not display in 3D or cross section/elevation views, but is added to the Materials List.

2 Course Spacing - Define the Wall Horizontal and Wall Vertical spacing for the rebar in the stem wall, and in Slabs. If

slabs are to have rebar instead of mesh, this spacing value applies to both directions.

3 Bar size - Define the rebar size in 1/8th inches. 4 represents 4/8, or 1/2 inch.

4 Specify the **Overlap** where sticks of rebar meet, in terms of the rebar's **Diameter**. A value of 40.0, for example, equals 40 times the Rebar Size.

5 Check **Use Mesh** to reinforce the slab floor with mesh instead of rebar, or uncheck it to use rebar.

- 6 Select either **Foam Seal**, **Termite Flashing** or both. These options are

added to the Materials List, but do not display in the model.

Building a Foundation



Foundations can be generated automatically or drawn manually. A combination of the two methods can also be used.

Three foundation types are available: stem walls with footings, walls with piers and monolithic slabs. The first two options are created using walls; the last creates concrete slabs with footings.

Automatically built foundations are placed on Floor 0 and are based on wall positions and floor heights on Floor 1. Foundation walls or slab footings are generated under:

- All exterior walls on Floor 1 that define a room other than a Court, Deck or Balcony room type. See “Room Definition” on page 231.
- Any interior walls on Floor 1 defining rooms with different floor heights. See “Floor & Ceiling Heights” on page 239.

At least one room must be defined on Floor 1 for a foundation to be automatically generated. If no rooms are defined on Floor 1, a blank Floor 0 is created.

Once a foundation is generated, you can add walls, piers, and slabs to customize it.

There can be only one Floor 0 per plan. If your plan requires a foundation on more than one floor, you will need to draw the required foundation walls or slabs yourself.

To build an automatic foundation

1. Select **Build> Floor> Build Foundation** .
2. Specify the desired foundation type and other information in the **Build Foundation** dialog. The settings in this dialog are similar to those in the Foundation Defaults dialog. See “Foundation Defaults” on page 330.
3. In the **New Floor** dialog, select **Derive new Foundation plan from the 1st floor plan** and click **OK** to build a foundation based on Floor 1.

If you prefer, you can instead select **Make new (blank) plan for the Foundation** to create an empty foundation level where you can manually draw foundation walls or slabs.

In most cases, it is preferable to base Floor 0 off the first floor plan and then manually edit the foundation as needed. See “Editing Foundations” on page 335.

Openings in Foundation Walls

Any doors placed in walls around a Garage will receive cutouts in the garage stem wall or curb. The width of that cutout can be specified in the **Door Specification** dialog. See “General Tab” on page 266.

Displaying Foundations



The display of foundation walls, slabs, curbs, piers and footings is controlled in the **Layer Display Options** dialog. See “Layer Display Options Dialog” on page 104.

- Foundation Walls, including grade beams, slab footings and Garage curbs, are placed on the “Walls, Foundation” layer.
- Footings under Foundation Walls and slab footings are placed on the “Footings” layer, as are foundation piers.
- Slabs created using the **Slab Tools**  are placed on the “Slabs, Custom” layer.

In Floor Plan View

The appearance of foundation wall types, including line weights, colors and fill styles, is specified in the **Wall Type Definitions** dialog. See “Wall Type Definitions Dialog” on page 211.

Changes in stem wall and monolithic slab foundation heights are represented in floor plan view with S markers. These markers are located on the “Footings, Step Markers” layer and use the Text Style assigned to that

layer. See “Stepped Foundations” on page 340.

If a door on Floor 1 extends into a stem wall or curb defining a Garage room, its location will be indicated on Floor 0. See “Displaying Doors” on page 257.

In 3D Views

In 3D views, all objects on Floor 0 will only display when the “Foundation” layer is turned on.

While the display of foundation walls and their footings can be controlled independent of one another in floor plan view, in 3D views this is not the case. If a foundation wall is set to display, its footing will as well - even if the “Footings” layer is turned off. The reverse is also true - if a foundation wall’s display is turned off, so will its footing’s.

The display of monolithic slab foundations in 3D views is controlled by the “Foundation” layer. Slab footings are located on the “Walls, Foundation” layer; but if this layer is turned off, any slab footings that define a foundation room will continue to display as long as the “Foundation” layer is on.

Editing Foundations

Stem wall with footings, wall with piers and monolithic slab foundations are all created using walls which enclose room areas.

- Foundation walls can be selected and edited much like other walls. See “Editing Walls” on page 197.
- Footing size can be changed on a wall by wall basis. See “Footing Width and Height” on page 337.
- Foundation rooms can also be selected and edited like other rooms. See Foundations and Rooms.

Rebuilding Foundations

By default, foundations do not update automatically when changes are made to the structure on Floor 1. For example, if exterior walls are moved or floor platforms are raised or lowered, the foundation must be rebuilt.

You can direct the program to rebuild an automatically generated foundation whenever changes are made on Floor 1 that affect the foundation by checking **Auto Rebuild Foundation** in the **Foundation Defaults** dialog. See “Foundation Tab” on page 331.

You can also rebuild an automatically generated foundation by selecting **Build> Floor> Build Foundation**  from the menu.

When **Auto Rebuild Foundation** is enabled, walls cannot be edited, manually drawn or deleted on Floor 0. When the foundation is rebuilt, any manually drawn or edited walls are deleted. Similarly, rooms on Floor 0 cannot be edited while this option is enabled.

Changing Foundation Types

When a foundation is generated, the program creates **Floor Defaults** settings for Floor 0 based on the information in the **Build Foundation** dialog. If you specify a Monolithic Slab foundation, the default Floor Structure on Floor 1 will also be changed to a slab rather than a framed platform. See “Floor Defaults Dialog” on page 316.

If you rebuild the foundation using a different Foundation Type, it is advisable to check the floor heights of all rooms on Floor 1 - particularly Garage and Slab rooms, as

well as any rooms that do not use the default floor height of 0”.



To avoid unexpected results, it is recommended that you not change the Foundation Type once the foundation is built.

Stem Wall Height

When a foundation is created, all of Floor 0 uses the stem wall height specified in the **Foundation Defaults** dialog,

This height is measured from the bottom of floor platform of Floor 1 to top of the stem walls’ footings. If Floor 1 has multiple floor platform heights, the foundation stem walls will be stepped.

Once a foundation is created, stem wall heights can be adjusted either on a room-by-room basis or for individual walls.

To change a room’s stem wall height

1. Select a room on Floor 0 and click the **Open Object**  edit button.
2. Specify the desired **Stem Wall Height** in the **Room Specification** dialog. See “General Tab” on page 244.
3. If you wish to reduce the **Stem Wall Height**, you will first need to reduce the **Ceiling Height** value by the same amount.

If adjacent rooms have stem wall heights that differ by at least 1/16 of an inch, the stem wall separating them uses the larger of these two values.

In 3D views, individual stem walls can be selected and edited. In most cases, this method should only be used for stepping the

bottom of the foundation wall. See “Stepped Walls & Footings” on page 207.

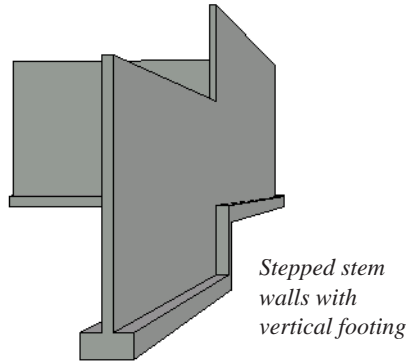

Footing Width and Height

Foundation Wall footings derive their Width and Height from in the **Foundation Wall Defaults** dialog. Once a Foundation Wall is created, its footing can be adjusted in its specification dialog. See “Foundation Tab” on page 219.

Stem wall footing heights can also be edited in 3D views just as the rest of the stem wall can. Slab footing heights, on the other hand, cannot be adjusted in 3D.



You can specify whether stepped stem walls have vertical footings on the Foundation tab

of the **Foundation Wall Defaults and Specification** dialogs.

Interior Footings

Slab foundations often have interior footings: to support posts, for example. See “Foundation Tab” on page 219. Home Designer Pro does not generate interior footings automatically, but you can easily draw them using the **Slab**  tool. See “The Slab Tools” on page 341.

To create an interior footing

1. Select **Build > Slab > Slab** , then click and drag to draw a slab on Floor 0. This slab will serve as a footing.
2. Select the slab and click the **Open Object**  edit button.
3. In the **Slab Specification** dialog, specify the desired **Height** and **Thickness**. See “General Tab” on page 342.
 - The **Height** should be set so that it meets the bottom surface of the monolithic slab above.
4. Use the edit handles, dimensions and/or the Reference Display to position the slab at the desired location.

Aligning Foundation Walls

By default, foundation walls and slab footings will align with walls on the floor above along the outside surface of the Main Layer of both wall types. See “Wall Type Definitions” on page 209.

If there is only one layer for both the stem wall and the first floor wall above it, the exterior surfaces of the walls align. The footing is centered on the stem wall.

Deleting Foundations



Select **Build> Floor> Delete Foundation** to delete the entire foundation floor.

You can also select and delete individual foundation walls and slabs by clicking the

Delete edit button or pressing the Delete key. See “Deleting Objects” on page 171.

Deleting and rebuilding the foundation is often the quickest way to update the model when substantial changes are made to Floor 1 after the foundation is built.

Foundations and Rooms

When a foundation plan is created, rooms included in the Living Area calculation generate a stem wall, grade beam, or slab foundation below them. Garage rooms generate slab foundations, but exterior rooms such as Decks, Courts and Balconies do not generate any foundation.

Interior foundation walls are not generated unless:

- They separate the area under a Slab or Garage room from the rest of the plan;
- They separate the area under a room specified as having a slab foundation from the rest of the plan;
- They define areas under rooms with different floor heights.

Note: To remove all or part of the concrete slab in the basement area, select a basement room and define it as Open Below in the Room Specification dialog.

Garages

When a foundation is generated based on the floor plan of Floor 1, a room on the first floor specified as either a Garage or Slab type will

receive a stem wall or pier foundation with a slab floor and stem walls. If a monolithic slab foundation is generated, the room will receive a slab floor with curbs.

An opening placed in a wall defining a Garage will receive a cutout in the stem wall or curb that displays in floor plan view on the floor below. The width of the concrete cutout can be defined, and you can specify whether the cutout displays, in the **Door or Window Specification** dialog. See “General Tab” on page 266.

By default, a room on Floor 1 specified as a Garage or a Slab will be assigned a lower floor height when the foundation is built. The amount that it is lowered depends on the foundation type:

- The floor height will drop the default thickness of the floor platform for Floor 1 plus 12” (300 mm) in a Walls with Footings or Walls with Piers foundation.
- The floor height will drop 3 1/2” (88 mm) in a Monolithic Slab foundation.

These values are set in the **Foundation Defaults** dialog. See “Foundation Tab” on page 331.

To build a Garage slab with stem walls

1. Before the foundation is generated, specify the room as a Garage or Slab.
2. Build an automatic Wall with Footings or Walls with Piers foundation.

In the Floor 1 Garage's **Room Specification** dialog, **Floor Supplied by the Foundation Room Below** will now be checked. See "Structure Tab" on page 245.

By default, the program produces a 4" (100 mm) slab and 24" (600 mm) high stem walls around the garage. These stem walls are drawn on Floor 0 and will indicate the locations of any doors that extend into them.

To build a Garage slab with curbs

1. Before the foundation is generated, specify the room as a Garage or Slab.
2. Build an automatic Monolithic Slab foundation, specifying the required Lower Garage Floor value.

By default, the program produces a 4" (100 mm) slab and 3 1/2" (88 mm) high curb around the garage. The curbs are drawn on Floor 0, use the Default Foundation Wall type, and will indicate the locations of any doors that extend into them.

The floor height of the garage and the stem wall or curb height can then be adjusted, if necessary, in the Garage room's **Room Specification** dialog. See "Structure Tab" on page 245.

Basement Rooms

When a foundation's type is Walls with Footings or Walls with Piers, and it is assigned a Minimum Wall Height of 76" (1900 mm) or greater, the resulting basement is automatically created with a 4" (100 mm) concrete slab floor.

Similarly, if a foundation is set up to have a Basement Ceiling Height of 72" (1800 mm) or greater when built, it is automatically given a painted drywall Ceiling Finish. See "Foundation Tab" on page 331.

Regardless of its ceiling height, however, you can specify a ceiling finish for any room in the **Room Specification** dialog. See "Structure Tab" on page 245.

The resulting basement can be divided into separate rooms using **Interior Walls**  or any wall type you wish. If the rooms in a basement have different floor heights, it is best to separate them using walls specified as

Foundation Walls .

Foundations and the Terrain

Home Designer Pro automatically positions the terrain a set distance below Floor 1. See "Terrain Height vs Floor Height" on page 539.

In a plan with a foundation present, this distance will be:

- 6" (187 mm) below the top of the stem walls or grade beams in a Walls with Footings or Walls with Piers foundation.
- 8" (200 mm) below the top of the slab in a Monolithic Slab foundation.

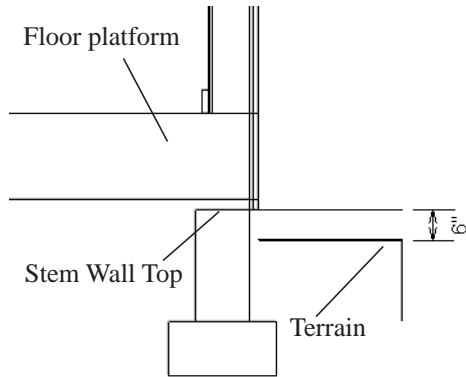

By default, the program will also create a flattened pad under the building footprint.

Not all foundations have these requirements, of course, so you can customize your foundation and terrain to suit your needs.

Daylight Basements

Daylight basements, also referred to as look-out basements, have walls that are tall enough for basement windows to be positioned above the terrain. They are often found in split level or split entry structures.

To create a daylight basement condition, build a stem wall foundation and modify these settings in the **Terrain Specification** dialog:

- Uncheck **Auto Calculate Elevation**.
- Increase the **Building Pad Elevation**, which is the distance between the default floor height of Floor 1 and the terrain.

Walkout Basements

Walkout basements are a type of daylight basement typically located on sloped terrain. They feature walls that are above ground at

the lower end of the slope so that a door can be positioned above the terrain at that end.

To create a walkout basement, build a stem wall foundation and modify these settings in the **Terrain Specification** dialog:

- Uncheck **Flatten Pad**.
- Uncheck **Auto Calculate Elevation**.

You will also need to create sloped terrain and adjust the **Building Pad Elevation** and/or terrain data so that the terrain is at the appropriate height relative to the structure at both the high and low ends of the slope.

Stepped Foundations

Stepped foundations are usually built on sloping terrain. A stepped foundation will be produced automatically if more than one floor height is present on Floor 1 when the foundation is built.

In floor plan view, steps in stem wall and monolithic slab foundations are represented using S markers. See “Displaying Foundations” on page 335.

As with a walkout basement, you will need to build a stem wall foundation and modify these settings in the **Terrain Specification** dialog:

- Uncheck **Flatten Pad**.
- Uncheck **Auto Calculate Elevation**.

You will also need to create sloped terrain and adjust the **Building Pad Elevation** and/or terrain data so that the terrain is at the appropriate height relative to the structure at both the high and low ends of the slope.

You can also create a stepped foundation by editing foundation rooms and walls. See “Stem Wall Height” on page 336.

The Slab Tools



Select **Build> Slab** to access the Slab Tools. The Slab Tools are designed for more generic purposes than foundations and should not be substituted for a foundation plan. The settings in the **Foundation Defaults** dialog do not affect slabs created with the Slab Tools.

Slabs



Select **Build> Slab> Slab** or **Slab With Footing**, then either click or click and drag a rectangle to draw a slab. See “Rectangular Polyline” on page 794.

Once created, slabs can be edited like other closed polylines. See “Editing Closed-Polyline Based Objects” on page 138.

Piers & Pads



Piers and pads can be manually placed under walls, railings, or beams on any floor. Select **Build> Slab> Round Pier** or **Build> Slab> Square Pad** and click in floor plan view to place a pier or pad.

For information about editing Piers and Pads, see “Editing Piers and Pads” on page 341.

Slabs and the Materials List

If the slab material type is specified as Concrete or Volume, the materials list calculates the total volume of the slab and all footings. See “Define Material Dialog” on page 643.

Editing Slabs

Slabs and Slab Holes can be selected in 2D and 3D views both individually and as a group and can be edited using the edit handles, the edit toolbar and the **Slab Specification** dialog. See “Slab Specification Dialog” on page 342.

Using the Mouse

Slabs and Slab Holes can be edited like other closed-polyline base objects in both 2D and

3D views. See “Editing Closed-Polyline Based Objects” on page 138.

Using the Edit Tools

One or more selected Slabs or Slab Holes can be edited in a variety of ways using the buttons on the edit toolbar. As with most objects, slabs can be copied, replicated, moved, deleted, etc. See “The Edit Toolbar” on page 29.

Editing Piers and Pads

Round Piers and Square Pads can be selected individually and in groups in 2D and 3D

views and edited using their edit handles and edit toolbars.

There are several ways to move piers and pads; however, they must always be positioned under a wall. A pier or pad can only be moved away from the wall it is placed beneath if it is moved to another wall.

Using the Mouse

In floor plan view, piers and pads can be edited like CAD lines. Three edit handles allow the pier or pad to be resized and moved along the wall it is placed beneath. See “Editing Line Based Objects” on page 127.

In 3D views, piers and pads can be edited like CAD boxes. See “Editing Box-Based Objects” on page 141.

Using Dimensions

In floor plan view, piers and pads can also be moved using dimensions. See “Moving Objects Using Dimensions” on page 737.

 If you move a foundation wall or beam, any piers or pads it contains move with it.

Using the Edit Tools

A selected pier or pad can be edited in a variety of ways using the buttons on the edit toolbar. As with most objects, piers and pads can be copied, replicated, moved, deleted, etc. See “The Edit Toolbar” on page 29.

Slab Specification Dialog



Select a slab and click the **Open Object** edit button to open the **Slab Specification** dialog.

General Tab

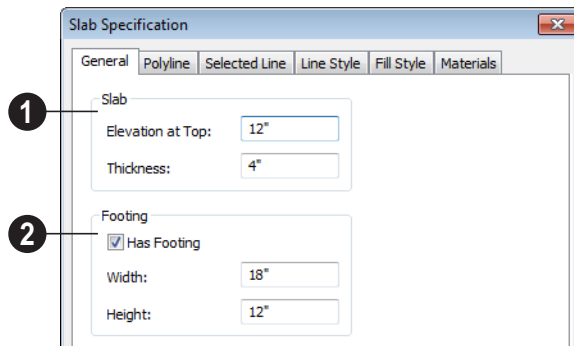

- 1 Specify the characteristics of the selected **Slab**.
- Specify the **Elevation at Top**, which is the height of the slab’s top surface.

- Specify the **Thickness**, which is the measurement from the slab's top to bottom surface.
- ② Specify the characteristics of the selected slab's **Footing**.
- Check **Has Footing** if you would like the slab to have a footing around the inside of its perimeter.
- Specify the **Height** and **Width** for the footing.

Polyline Tab

The **Length/Perimeter**, total **Area**, and **Volume** of the selected slab displays here. The volume is the amount of concrete required to pour the slab.

Selected Line Tab

The Selected Line tab is available when the selected edge is a line as opposed to an arc. For information about the settings on this

tab, see "Polyline Specification Dialog" on page 791.

Selected Arc Tab

The Selected Line tab is available when the selected edge is an arc as opposed to a line. See "Change Line/Arc" on page 159.

Line Style Tab

For information about the settings on this tab, see "Line Specification Dialog" on page 780.

Fill Style Tab

The settings on the Fill Style tab affect the selected slab's appearance in floor plan view. For information about these settings, see "Fill Style Tab" on page 792.

Materials Tab

For information about the settings on this tab, see "Materials Tab" on page 635.

Fireplaces



A masonry fireplace can be placed in or away from a wall by selecting **Build > Fireplace** and then clicking in the drawing area.

- If created in a wall, it is considered a wall opening and can be moved or resized like a window or door.
- If created away from a wall, it moves and resizes similar to a cabinet.

A selection of prefabricated metal fireplaces is also available from the Fixtures (Interior) library category. These can be framed in with standard walls. See "The Library" on page 603.

The display of fireplaces is controlled in the **Layer Display Options** dialog. See "Layer Display Options Dialog" on page 104.

Fireplaces are edited, moved, resized, and deleted similar other objects. See "Editing Objects" on page 119.

Built into a Wall

To place a masonry fireplace in a wall, select **Build> Fireplace**  and click on a wall. A fireplace is created with the outside of the fireplace flush with the outside of the wall.

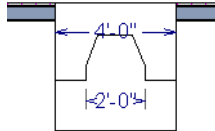

Select the fireplace to display four edit handles located along the wall.

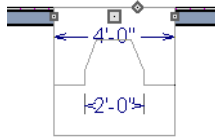

Click the diamond-shaped Depth handle and drag toward the outside of the wall. The fireplace will stop when the firebox front is flush with the inside edge of the wall.

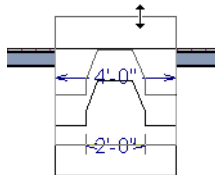

In 3D views, fireplaces placed in walls display five edit handles: a Resize handle along each edge and a Move handle at the center.

Fireplaces always face the interior when placed on an exterior wall. When placing a fireplace in an interior wall, click on the edge of the wall that you want the fireplace to face. The fireplace is created with the firebox

on the same side as the wall edge you clicked on to create it.

Freestanding

To place a free-standing masonry fireplace, select **Build> Fireplace**  and click in an open area away from a wall.

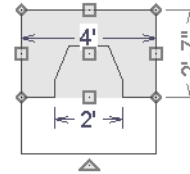

Unlike fireplaces placed in walls, free-standing fireplace have ten edit handles when selected and may be rotated, resized, or moved in any direction, similar to the way CAD boxes can. See “Editing Box-Based Objects” on page 141.

Free-standing fireplaces can be selected and replaced with a symbol from the library by clicking the **Replace From Library**  edit button. See “Replace From Library” on page 624.

Fireplace Foundations

When a Walls with Footings or Walls with Piers foundation is built, a fireplace foundation will be generated under any **Fireplaces**  present on Floor 1. See “Building a Foundation” on page 334.

Fireplace foundations are the same material type as the original fireplace, but do not have a firebox or a hearth. Fireplace foundations can be edited or deleted as needed. A firebox and hearth can be added in the **Fireplace Specification** dialog.

Fireplace Specification Dialog

 Select a masonry fireplace and click the **Open Object** edit button to display the **Fireplace Specification** dialog. Multiple fireplaces can be group-selected,

but all objects in selection group must be either placed in a wall or free-standing.

Dimensions in this dialog here must be entered in whole inches. Fractions and decimals are not accepted.

General Tab

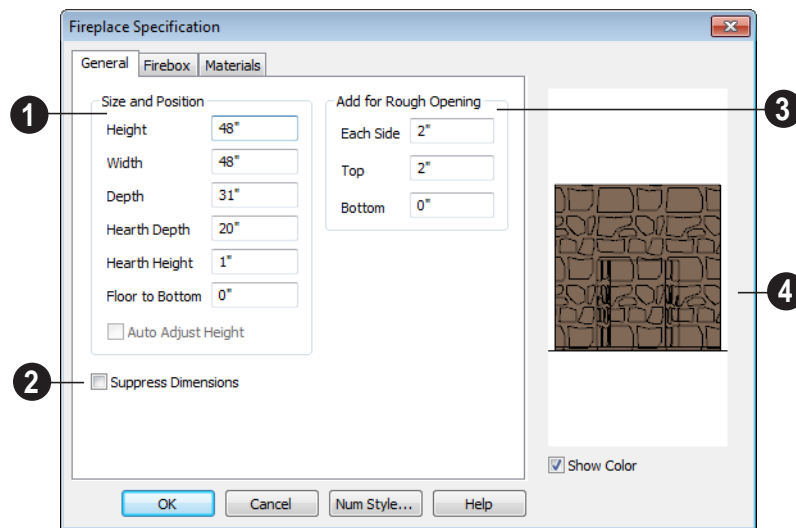

- 1 Specify the **Size and Position** of the selected fireplace and its hearth.
 - Specify the **Height** of the fireplace.
 - Specify the **Width** of the fireplace.
 - Specify the **Depth** of the fireplace.
 - Specify the **Hearth Depth**. This is measured from the front of the fireplace out into the room. To eliminate the hearth altogether, enter a zero for this value.
 - Specify the **Hearth Height**, relative to the floor in that room.
- Enter the **Floor to Bottom** distance from the floor to the bottom of the hearth.
- When the selected free-standing fireplace is outside a room and **Auto Adjust Height** is checked, its Floor to Bottom height is measured relative to the terrain height. When this is unchecked, the Floor to Bottom height is measured from the default floor height of Floor 1. Only available for free-standing fireplaces. See “Terrain Height vs Floor Height” on page 539 of the Reference Manual.

- 2 Check **Suppress Dimensions** to turn off the display of the selected fireplace's width and firebox width dimensions in floor plan view.
- 3 **Add for Rough Opening** - Specify the amount to add to **Each Side**, the **Top** and the **Bottom** for the fireplace's framed rough opening. Only available for a fireplace

placed in a wall, **Each Side** and **Top** are set to 2" (50 mm) by default.

If the Bottom Rough Opening value exceeds the fireplace's distance to the floor, the difference is added to the top when wall framing is built. See "Framing" on page 435.

- 4 The preview image of the fireplace updates as changes are made. Press the Tab key to update to the most recent change.

Firebox Tab

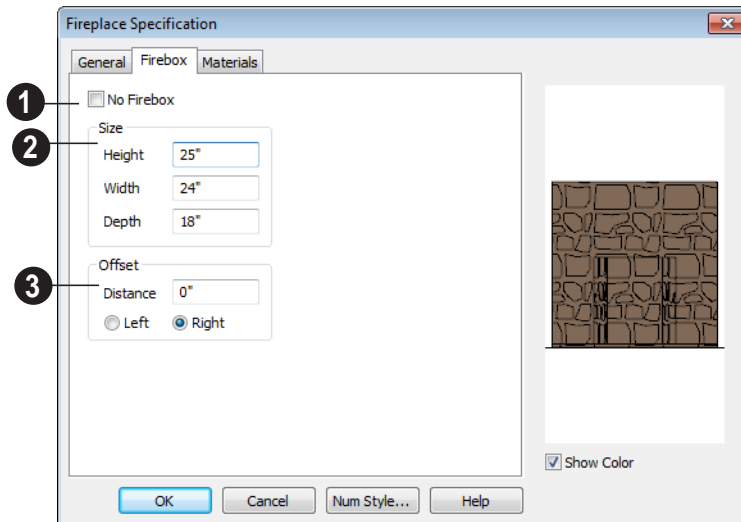

- 1 Check **No Firebox** to eliminate the firebox from the fireplace. This is checked by default for a fireplace object generated on Floor 0 to serve as a solid matching base for a fireplace on Floor 1.
- 2 Define the **Size** of the selected fireplace's firebox.
 - Specify the firebox's **Height** and **Width**.
 - Specify the **Depth** of the firebox.

- The defaults are 25, 24, and 18 inches respectively.
- 3 Define the firebox **Offset**, measured from the center of the fireplace.
 - Enter offset **Distance**, which is how far the firebox is offset from the fireplace center. A value of 0 centers the fire box in the fireplace.
 - **Offset to Left/Right** - Choose to offset the firebox to the left or to the right.

Materials Tab

For information about the settings on this tab, see “Materials Tab” on page 635.

Library Fireplaces

A variety of different fireplace symbols are available in library. The fireplace symbols in the Library behave just like other Library objects. See “The Library” on page 603.



Always check the manufacturer's product information for the framing and clearance requirements of the fireplace unit you plan to use, and design your plan accordingly

Placing a Library Fireplace

A variety of fireplace symbols are available in the library. See “Placing Library Objects” on page 620.

Flush fireplaces are designed to snap to wall surfaces.

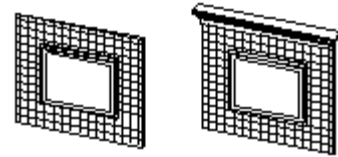

Flush Fireplace Flush Fireplace

Some fireplace symbols can be enclosed by walls or positioned to project through a wall.

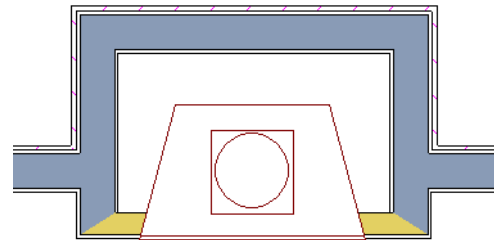

Open Front fireplace projecting through a wall

Chimneys

Chimneys can be created using a variety of methods.

Masonry Fireplace Chimneys

To create a chimney on a masonry fireplace

1. Select the fireplace in a 3D view.
2. Ctrl + drag the top edge of the chimney upward through all the floors and the roof until it is to the desired height. See “Unrestricted Movement” on page 153.
3. When the chimney is approximately the correct height, select the fireplace, click the **Open Object**  edit button, and type in the exact height.

Chimney Chases & Caps

There are two ways to draw a chimney chase.

- Place a closed box geometric shape or soffit in position over the chimney chase, resize it to match, then increase its height either in its specification dialog or in a 3D view using the same method as extending a masonry fireplace.
- Define the chimney chase as a room area using walls, making sure these walls are aligned between floors. The chimney

chase “room” on the uppermost floor should have a much higher ceiling than the other rooms on that floor and should also have no ceiling or roof. See “Room Specification Dialog” on page 244.

A selection of chimney tops is available in the library. In addition, custom chimney caps can be made using Geometric Shapes and/or soffits. See “General Shapes” on page 589 and “Soffits” on page 589.

Roofs

Home Designer Pro's manual and automatic Roof Tools allow you to draw almost any roof style.

Proficiency with the Roof Tools can only be attained through practice, but mastering these tools saves you time and effort in plan development. For information about creating specific roof styles, see "Roof Tutorial" on page 69 of the User's Guide.



Verify that all roof planes join as intended. The program does not confirm correct geometry between manually designed or edited roof planes. It is possible to design and edit roof planes with hips and valleys that do not meet properly.

Chapter Contents

- Automatic vs. Manual Roofs
- Roof Defaults
- The Roof Tools
- Automatic Roofs
- Build Roof Dialog
- Roof Planes
- Displaying Roofs
- Editing Roof and Ceiling Planes
- Roof Plane Specification Dialog
- Roof Baseline Polylines
- Roof Baseline Specification Dialog
- Roof and Ceiling Framing
- Ceiling Planes
- Ceiling Plane Specification Dialog
- Gable/Roof Lines
- Skylights
- Roof Hole/Skylight Specification Dialog
- Dormers and Crickets
- Editing Auto Dormers
- Dormer Specification Dialog
- Roof Returns and Other Details
- Roof Pitches in Degrees

Automatic vs. Manual Roofs

Home Designer Pro can create just about any roof style. Most common roof styles such as hips and gables can easily be generated automatically. See “Roof Tutorial” on page 69 of the User’s Guide.

More complex roof styles, including curved roof planes, can be created manually. The manual roof tools allow you to create any roof system that can be represented using roof planes.

Automatically Generated Roofs

The quickest and easiest way to create a roof over a structure is automatically. By default, a roof plane is generated over each exterior wall, creating a hip roof. The program automatically joins the roof planes at ridges, hips, and valleys and tries to create roof planes that join together to form a single, integrated system. See “Automatic Roofs” on page 353.

Any deviations from the default hip roof can be specified on the Roof tab of the **Wall Specification** dialog for any exterior wall. Here, you can specify a Full Gable Wall, High/Shed Gable Wall, or other options instead of a default hip roof. You can also specify a different overhang, pitch, an upper pitch, and the elevation where the upper pitch begins for the roof plane that rests on the selected wall. See “Roof Directives in Walls” on page 204.

When you need the roof planes over an area of a plan to be entirely separate from those over the rest of the structure, you can assign

those areas to a non-default Roof Group. See “Roof Groups” on page 353.

Roofs can also be automatically generated based on a Roof Baseline Polyline. When a Roof Baseline Polyline is used, information that determines where and how roof planes are generated is contained in the **Roof Baseline Specification** dialog. See “Roof Baseline Polyline” on page 375.

Bay, bow, and box windows also produce roof planes automatically. For information about these windows and the roof styles that can be used with them, see “Bay, Box, Bow Windows & Roofs” on page 292.

Manually Drawn Roofs

Any roof system that can be created automatically can also be created manually. Each roof plane is drawn and edited individually, offering full control over the process and limiting the possibilities only to your imagination.

Note: You cannot manually draw or edit roof planes when Auto Rebuild Roofs is enabled in the Build Roof dialog. See “Roof Tab” on page 356.

Using Both Techniques

Another useful option is to start with an automatically generated roof and use manual design techniques to finish it. Using both automatic roof generation and the manual roof drawing and editing techniques, you can quickly design highly customized roof systems.

Roof Defaults



Select **Edit> Default Settings**, to open the **Default Settings** dialog for a variety of drawing tools, several of which directly affect roof generation.

Build Roof Dialog

While not listed in the **Default Settings** dialog, the **Build Roof** dialog functions as the defaults dialog for roofs. Many, but not all, initial default values for both manually drawn and automatically generated roofs are set in this dialog. See “Build Roof Dialog” on page 355.

If changes are made to the settings in this dialog after the roof has been built, you will need to rebuild the roof in order for your changes to take effect.

Roof Framing Defaults

Default settings for framing can be specified in either the **Build Roof** or the **Framing Defaults** dialog. Framing defaults control the depth of roof planes as well as the depth of floor and ceiling platforms, which influence roof plane heights. See “Framing Defaults” on page 436.

To create roof planes of a particular depth, begin by setting up the desired roof framing defaults, then build the roof. If you later need to change the structure of the roof planes, make the needed change to the Framing Defaults, and then rebuild the roof. You can also edit the structure of individual roof planes.

Floor and Ceiling Heights

The initial heights of floors and ceilings, which influence roof heights, are specified in the **Floor Defaults** dialog for each floor. See “Floor Defaults Dialog” on page 316.

The floor and ceiling heights in individual rooms also influence roof heights and are specified in the **Room Specification** dialog. See “Structure Tab” on page 245.



If Auto Rebuild Roofs is checked in the Build Roof dialog and you change floor or ceiling heights, floor or ceiling platform depths, wall positions or roof directives in walls, the roof rebuilds to reflect your changes. See “Rebuilding Roofs” on page 355.

Wall Specification Dialog

By default, when an automatic roof is built, a roof plane is generated over each exterior wall, creating a hip roof.

Any deviations from this default hip roof, such as a gable or a different pitch, can be specified in the **Wall Specification** dialog for any exterior wall. See “Roof Tab” on page 218.

Dormer Defaults

The settings in the **Dormer Defaults** dialog determine the initial settings for automatic dormers and are much like those in the **Dormer Specification** dialog. See “Dormer Specification Dialog” on page 391.

The **Dormer Defaults** dialog can be opened from the **Default Settings** dialog or by

double-clicking either of the **Auto**

Dormer  tools.

The Roof Tools



Select **Build> Roof** to access the Roof Tools.

Build Roof



Select **Build> Roof> Build Roof** to open the **Build Roof** dialog, specify the settings for automatically generated and manually drawn roof planes as well as manually drawn ceiling planes, and build or rebuild a roof. See “Build Roof Dialog” on page 355.

When roofs are automatically generated, a roof plane is created over each exterior wall by default, resulting in a hip roof, and the program tries to join them together to form a single, integrated system.

To automatically generate a roof plane using values other than the defaults or to not generate a roof plane bearing on a particular wall (as with a gable or the sides of a shed roof), you can change the settings in the **Wall Specification** dialog. See “Roof Tab” on page 218.

For more information about creating different roof styles, see “Roof Tutorial” on page 69 of the User’s Guide.

Roof Plane



Select **Build> Roof> Roof Plane** to draw a roof plane manually. See “Roof Planes” on page 362. You can also double-click the **Roof Plane** button to open the **Build Roof** dialog.

Note: You cannot use the Roof Plane tool when Auto Rebuild Roofs is enabled in the Build Roof dialog. See “Manually Drawn Roofs” on page 350.

Ceiling Plane



Select **Build> Roof> Ceiling Plane** to draw a ceiling plane manually. Ceiling planes are drawn and behave much like roof planes. See “Ceiling Planes” on page 379.

Gable/Roof Line



Select **Build> Roof> Gable/Roof Line** to draw a gable line that generates a gable along a baseline edge when roofs are automatically generated. See “Gable/Roof Lines” on page 382.

Skylight



Select **Build> Roof> Skylight**, then draw a rectangle over an existing roof plane to create a skylight. The skylight, skylight shaft, and ceiling hole (if a ceiling exists) are drawn at the same time. See “Skylights” on page 385.

Auto Floating Dormer



Select **Build> Roof> Auto Floating Dormer** and click within an existing roof plane to place an auto floating dormer. See “Dormers and Crickets” on page 387.

Auto Dormer



Select **Build> Roof> Auto Dormer** and click within a roof plane to place a dormer. See “Dormers and Crickets” on page 387.

Delete Roof Planes



Select **Build> Roof> Delete Roof Planes** to delete all roof planes in the plan. See “Deleting Roof Planes” on page 371.

Delete Ceiling Planes

Select **Build> Roof> Delete Ceiling Planes** to delete all manually drawn ceiling planes in the plan. See “Ceiling Planes” on page 379.

Fix Roofs



Select **Build> Roof> Fix Roofs** to remove breaks where a single edge of one roof plane meets the broken edge of another along a ridge, hip or valley. **Fix Roofs** does not affect eave edges. See “Aligning Roof Edges” on page 366.

Automatic Roofs

When roofs are automatically generated, a roof plane is created over each exterior wall by default, resulting in a hip roof, and the program tries to join them together to form a single, integrated system.

There are a number of options available to produce variations in this default roof style.

Roof Directives in Walls

To automatically generate a roof plane using values other than the defaults or to not generate a roof plane bearing on a particular wall (as with a gable or the sides of a shed roof), you can change the settings in the **Wall Specification** dialog for that wall. See “Roof Tab” on page 218.

For more information about creating different roof styles, see “Roof Tutorial” on page 69 of the User’s Guide.

Roof Groups

When an automatic roof is generated, the program tries to create roof planes that join together to form a single, integrated system. Different parts of the structure influence how the roof is generated over the whole.

When you need the roof planes over an area of a plan to be entirely separate from those over the rest of the structure, you can assign those areas to a non-default Roof Group. The program treats different Roof Groups as separate buildings for the purpose of automatic roof generation, preventing their roofs from influencing one another.

Bear in mind that the use of Roof Groups typically involves using a combination of both automatic roof generation and manual roof editing, and that changes to Attic walls may also be necessary. See “Using Both Techniques” on page 350.

Roof Groups are assigned using numbers. The Default Roof Group is always 0, and you

can assign rooms to other roof groups in the **Room Specification** dialog. See “General Tab” on page 244.

Curved Walls and Roofs

Automatically generated roof planes are placed over curved walls at specified increments. In the **Build Roof** dialog, you can specify the degree increments for the roof over curved walls, from 6° to 90°. The

lower the number, the more roof sections are created over the curved wall.

The following illustrations show a roof created at two different curved increments: 30° and 15°.

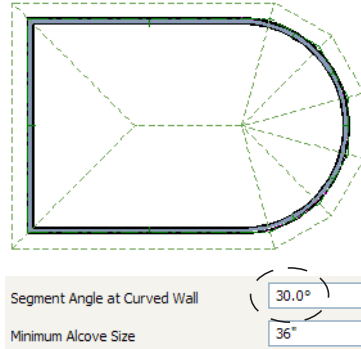
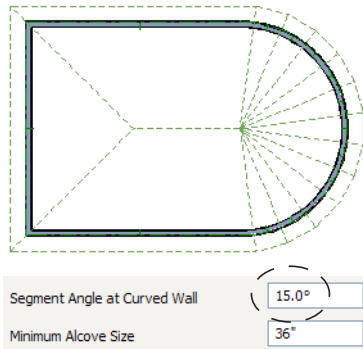

Concave Curved Walls & Roofs

Regular roof plane sections can also generate over concave curved walls. For roof sections to generate over a concave curved wall, the sections’ baselines must be longer than the **Minimum Alcove Size** value on the Build tab of the **Build Roof** dialog.

If the baselines are shorter, the automatically generated roofs are simplified by either:

- Ignoring the curved wall, as if the walls on either side extended to their meeting point.

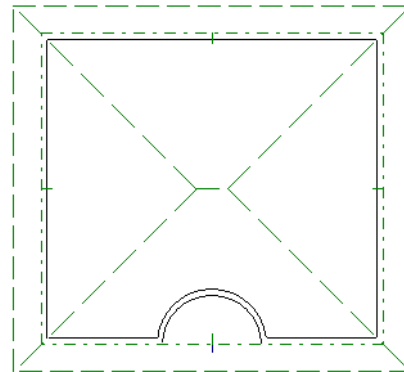

- Spanning the concave curved wall with a straight Baseline and produce a roof plane for it from that.

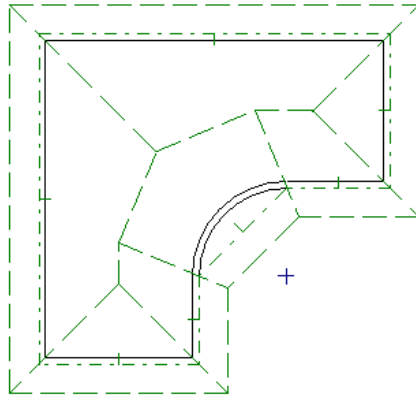

Rebuilding Roofs

By default, when changes are made to the model, the roof does not update to reflect these changes. This is the case even if the roof was automatically built.

When **Auto Rebuild Roofs** is checked in the **Build Roofs** dialog, on the other hand, any changes made to the position of an exterior wall or to its roof directives will prompt the roof to regenerate to reflect these changes. See “Roof Tab” on page 356.

Changes made to floor heights, ceiling heights, or floor or ceiling platform thicknesses will also cause the roof to be automatically rebuilt.

You can also rebuild the roof at any time to reflect the current state of the model by opening the **Build Roof** dialog, checking **Build Roof Planes**, and clicking OK.

When the roof is rebuilt using **Auto Rebuild Roof** or **Build Roof Planes** in the **Build Roof** dialog, all roof planes in the plan, both automatically generated and manually drawn, are deleted and replaced.

- To preserve any manually drawn roof planes, check **Retain Manually Drawn Roof Planes** on the Build tab of the **Build Roof** dialog before the roof is rebuilt.
- To preserve any automatically generated roof planes that you have edited, check **Retain Edited Roof Planes** on the Build tab of the **Build Roof** dialog before the roof is rebuilt.

Note: Under some conditions, when the roof is rebuilt new roof planes may be generated in the same location as retained manually drawn or automatic roof planes.

Roof planes cannot be edited or manually drawn when **Auto Rebuild Roofs** is turned on. If you try to either edit or draw a roof plane using the **Roof Plane**  tool, a warning message will display.

Build Roof Dialog



The **Build Roof** dialog is used to automatically build or rebuild roof planes and generate Roof Baseline Polylines. The settings in this dialog act as defaults for both manually drawn and automatic roofs. See “Roof Defaults” on page 351.

To open the **Build Roof** dialog, select **Build> Roof> Build Roof** . You can also double-click the **Roof Tools**  button or the **Roof Plane**  button to open this dialog.

Roof planes and Roof Baseline Polyline are generated based on the positions and roof directive settings for each exterior wall in the plan. If you make changes to any of these walls or to any of the settings in this dialog, you will need to build the roof again for them to take effect. See “Roof Tab” on page 218.

The settings in this dialog are similar to those found in the **Roof Plane Specification** dialog, but affect all subsequently created roof planes rather than one or more selected

roof planes. See “Roof Plane Specification Dialog” on page 371.

There are six tabs in the **Build Roof** dialog:

- Roof Tab
- Options Tab
- Framing Tab
- Arrow Tab
- Materials Tab
- Roof Styles Tab

Roof Tab

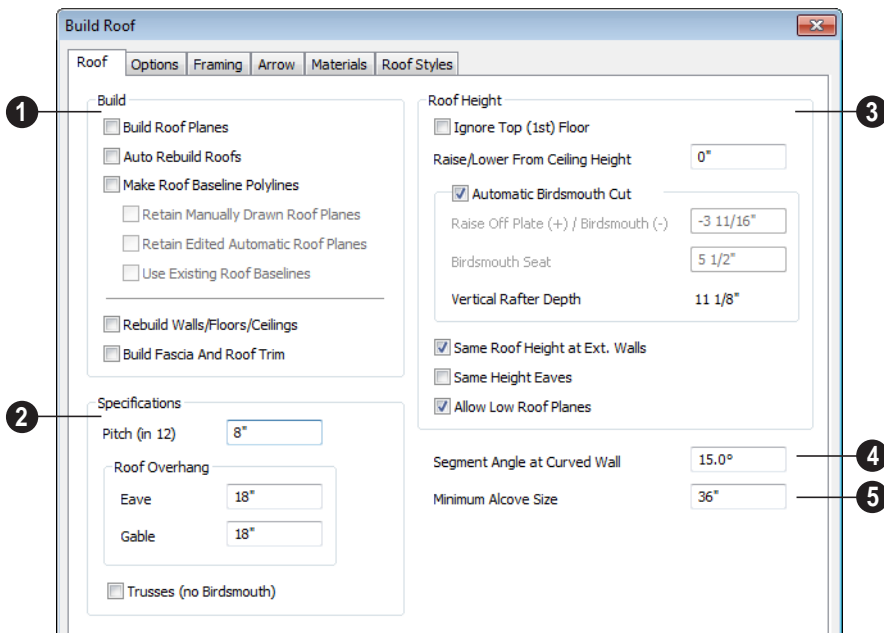

1 The **Build** options are commands related to building and rebuilding roof planes.

- Check **Build Roof Planes** to build a new roof structure over the entire model. Unless you specify otherwise, the pro-

gram discards the existing roof planes and produces new ones.

- If you check **Auto Rebuild Roofs**, the program automatically rebuilds the roof whenever you make a change that affects the generation of roofs, such as changes to exterior walls or ceiling heights.

- Check **Make Roof Baseline Polyline**s to delete the existing roof and to create Roof Baseline Polyline(s) based on the exterior wall layout and roof information defined in those walls. If checked, **Build Roof Planes** becomes unchecked. See “Roof Baseline Polyline(s)” on page 375.

Specify how manually drawn or edited roof planes are handled when the roof is rebuilt automatically. These options are only available when **Build Roof Planes** is checked. See “Rebuilding Roofs” on page 355.

- Check **Retain Manually Drawn Roof Planes** to prevent manually drawn roof planes from being deleted when roof planes are rebuilt. Automatic roof planes may be generated in the same location. Also available if **Make Roof Baseline Polyline**s is checked.
- Check **Retain Edited Automatic Roof Planes** to prevent automatic roof planes that have been manually edited - including roof planes over exploded dormers - from being deleted when roof planes are rebuilt. Also available if **Make Roof Baseline Polyline**s is checked.

If a newly generated roof plane is coplanar with a retained plane, and the area by which they overlap is at least half the area of either of them, the new roof plane is deleted and only the retained plane is kept.

Note: Under some conditions, new roof planes may be generated in the same location as manually drawn or automatic roof planes that have been retained.

- Check **Use Existing Roof Baselines** to produce a roof plan based on your Roof Baseline Polyline(s) instead of the exterior wall layout.

You can also rebuild aspects of the structure related to roofs.

- Check **Rebuild Walls/Floors/Ceilings** to rebuild the walls and floor and ceiling platforms of your model before the roof is built. It is independent of **Build Roof Planes** and helps ensure that your roof is generated based on the most up-to-date model. See “Rebuilding Walls, Floors & Ceilings” on page 324.
- Check **Build Fascia and Roof Trim** to regenerate fascia and gutters. See “Fascia” on page 393. You can check this box without also rebuilding the roof.

Build Fascia and Roof Trim is invoked automatically after you manually edit roof planes or draw new roof planes if **Auto Rebuild Walls/Floors/Ceilings** is checked in the **3D View Defaults** dialog. See “Options Tab” on page 669.

2 The options in the **Specifications section** are basic roof structure settings.

- Enter a value to describe the **Pitch** as a ratio over 12. For a conversion to degrees, see “Roof Pitches in Degrees” on page 395.

Roof Overhang is measured horizontally from the outside Main Layer of exterior walls to the end of the top of the rafter. It includes fascia but not gutters. See “The Main Layer” on page 209.

- **Eave** is the overhang distance outside of bearing walls for roof planes using the default Pitch. If a particular roof plane has

a different Pitch, its overhang will adjust to keep its fascia at the same height. Overhang may be greater for a shallower pitch, lesser for a greater pitch.

- **Gable** is the overhang distance at gable ends or rake walls.



If the roof overhang values are not sufficient to extend past the outer surface of exterior walls, the walls may not generate correctly in 3D views.

Check **Trusses (no Birdsmouth)** if you wish to frame the roof using trusses rather than rafters. The roof is raised so that the bottom edge of the truss top chord (or rafter) is flush with the top of the wall. See “Roof Trusses” on page 470.

- When **Trusses (no Birdsmouth)** is checked, roof plane depth is based on the **Top Chord** size specified in the **Framing Defaults** dialog. See “Trusses Tab” on page 453.
- When **Trusses (no Birdsmouth)** is unchecked, roof plane depth is based on the **Rafter Depth** specified in the **Framing Defaults** dialog. See “Roof Tab” on page 451.

If **Trusses (no Birdsmouth)** is unchecked when the roof is built, and you then draw a roof truss, its bottom chord may be longer than expected and its top chord, higher:

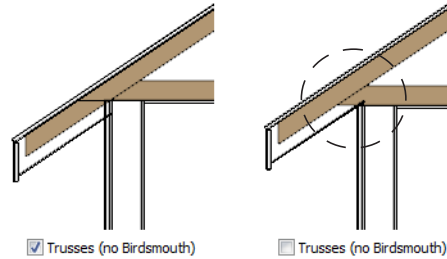

3 The **Roof Height** options affect the heights of roof planes.

- Check **Ignore Top Floor** to ignore the top living floor when roof planes are generated. Roof planes are built on the top plates of the walls below the top floor.

Specify the amount to **Raise/Lower From Ceiling Height**, which controls the height of roof planes relative to the ceiling height specified for the rooms below.

- The default value is 0, which creates roof planes that bear on the wall top plates at the Ceiling Height of the room below.
- Increase this value to raise roof planes so they do not bear directly on the wall top plates. If roofs are raised sufficiently, Attic walls will automatically generate to support them. The exact height depends on the roof pitch.
- Decrease this value to drop roof planes downward, decreasing the height of the bearing walls. If roofs are lowered sufficiently, they may cut extend into rooms, producing areas with angled ceilings.

Specify the structure of roof planes and how they bear on the walls below. The Raise Off Plate and Birdsmouth settings do not affect the bearing wall heights.

- Uncheck **Automatic Birdsmouth Cut** to specify the birdsmouth cut for stick framed roofs or the energy heel for roof trusses. When this box is checked, the program produces a birdsmouth cut, and no energy heel. See “Birdsmouth Cut” on page 371.
- Enter a positive **Raise Off Plate** value in this field to produce the trusses with an energy heel to allow for more insulation.
- Enter a negative **Birdsmouth Cut** value to control the Birdsmouth Depth. For example, for the Birdsmouth Depth of 3”, enter -3”. The location of the Baseline may change if you use the **Raise Off Plate** setting to specify the birdsmouth depth. See “Birdsmouth Cut” on page 371.
- Specify the **Birdsmouth Seat**, which is the horizontal depth of the birdsmouth cut. If you change this value, the **Raise Off Plate/Birdsmouth Cut** value will automatically adjust.

To control the Birdsmouth Cut, you should also check **Same Roof Height at External Walls**.

- The **Vertical Rafter Depth** displays here as a reference. It can be changed on the Framing tab. See “Framing Tab” on page 362.

Specify how you would like the eaves of roof planes with different pitches to meet. See “Aligning Eaves” on page 368.

- Check **Same Roof Height at External Walls** to keep bearing walls the same height and change horizontal roof overhang distances as needed so that eaves meet correctly. See “Aligning Eaves” on page 368.

When checked, this option ignores any overhang values you may have entered in the **Wall Specification** dialog. See “Roof Directives in Walls” on page 204.

Uncheck this option to raise or lower some roof planes relative to the wall’s top plate, allowing all horizontal overhangs to be the same unless a non-default value has been entered in the **Wall Specification** dialog.

- Check **Same Height Eaves** to keep the eave height for all roof planes the same. Roof planes are raised and lowered as needed so that eaves meet correctly.

The eave height used when this box is checked is that of a roof plane using the default Pitch and Overhang values. When this box is checked, all roof planes are affected, including those that do not need adjustment in order to align with adjacent planes.

When **Same Height Eaves** is checked, any non-default overhang values specified in the **Wall Specification** dialog are used. Roof planes are raised or lowered so that the eave height is the same, regardless of the horizontal overhang.

- Uncheck **Allow Low Roof Planes** only when an upper floor overhangs roof planes below.

- 4 **Segment Angle at Curved Wall -**
Enter the maximum angle for a roof segment that covers a curved wall. This value is only used when roofs are automatically generated. A smaller angle produces more roof planes.

5 Specify the **Minimum Alcove Size**, which is the minimum depth and width of an alcove (depression into an otherwise straight exterior wall). Any alcove with both a depth and width less than this value is treated as though the exterior wall continues straight across. Alcoves either wider or deeper than this value are not roofed over; they affect how the roof is generated.

The following is an example showing this difference. If **Minimum Alcove Size** is 36", a 36" wide alcove requires a change in the

roof line and each wall of the alcove has an eave. On the right, the alcove is less than the 36" minimum, so the roof builds right over it.

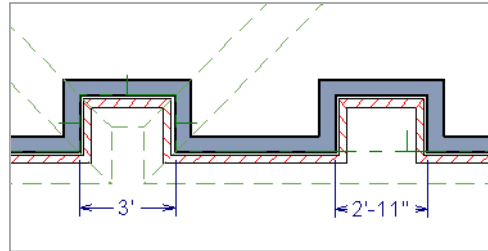

Options Tab

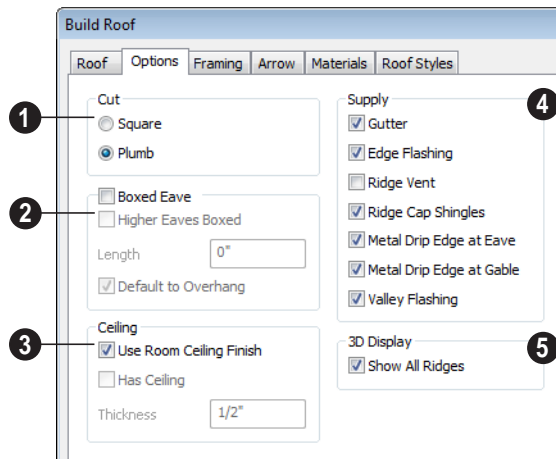

1 Select **Square Cut** or **Plumb Cut** to determine how the rafter tails are cut. This change displays only after you have rebuilt roofs. Individual roof planes can have this defined in their own **Roof Plane Specification** dialog.

2 Check **Boxed Eave** to produce horizontal boxed eaves or uncheck it

for sloping eaves. You can also change this for individual roof planes in the **Roof Plane Specification** dialog.

- **Higher Eaves Boxed** - If the selected roof plane contains more than one eave, check this box to box the higher eaves as well as the lower ones.

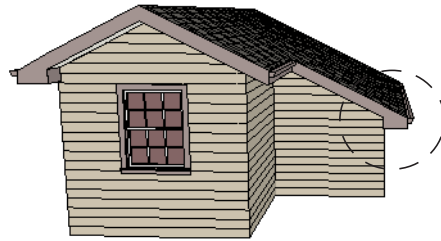

With Boxed Eave checked

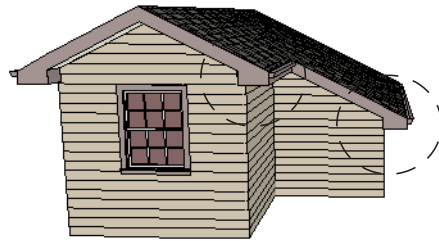

With Higher Eaves Boxed checked

- You can specify the **Length** of the boxed eaves or check **Default to Overhang** to extend the boxed eave from the edge of the roof to the exterior main layer of the wall, covering the overhang area.
- ③ Specify how the **Ceiling** surface on the underside of roof planes is built. See “Vaulted and Cathedral Ceilings” on page 242.
- When **Use Room Ceiling Finish** is checked, the ceiling finish thickness and material on the undersides of roof planes are defined by the room below. Uncheck this box to enable the two settings that follow and define the ceiling finish as part of the roof planes instead.
- Check **Has Ceiling** to enable the Ceiling Thickness option. When this box is unchecked, the selected roof plane will

have no ceiling surface at all and the “Ceiling Surface” component will not be available on the Materials tab.

- Specify the **Ceiling Thickness**, which is the thickness of the bottom surface of the ceiling plane.

When **Use Room Ceiling Finish** is unchecked, you can specify the Ceiling Surface material on the Materials Tab.

④ Specify the material components to **Supply** for subsequently-built roof planes. When checked, these items are calculated in the Materials List. See “Materials Lists” on page 887. Only Gutter is available in the **Roof Plane Specification** dialog.

- Uncheck **Gutter** to not include gutters on subsequently-built roof planes. This option affects both the Materials List and 3D views.
- Check **Edge Flashing** to calculate edge flashing in the Materials List.
- Check **Ridge Vent** to calculate ridge venting in the Materials List.
- Check **Ridge Cap Shingles** to calculate ridge caps in the Materials List.
- Check **Metal Drip Edge at Eave** to calculate metal drip edge along the eaves in the Materials List.
- Check **Metal Drip Edge at Gable** to calculate metal drip edge along any gable eaves in the Materials List.
- Check **Valley Flashing** to calculate valley flashing in the Materials List.

⑤ **3D Display** - When **Show All Ridges** is checked, a line along each hip between roof planes forming the conical roof above a curved wall displays in Vector Views.

Uncheck this box to suppress these lines. See “Rendered and Vector Views” on page 665.

Framing Tab

The settings on the Framing tab of the **Build Roof** dialog are the same as those on the Roof tab of the **Build Framing** dialog. Changes made in one dialog are also applied in the other. See “Roof Tab” on page 451.

Note: Changes made on the Framing tab will not affect the structure of existing roof planes. To make changes take effect, rebuild the roof.

Arrow Tab

The settings on this tab allow you to control the appearance of roof plane slope direction arrows. See “Displaying Roofs” on page 364.

For information about these settings, see “Arrow Tab” on page 783.

Materials Tab

The settings on this allow you to specify materials for the roof’s various components. See “Materials Tab” on page 635.

The “Ceiling Surface” component is only available when **Use Room Ceiling Finish** is unchecked on the Options Tab.

Roof Styles Tab

The Roof Styles tab provides links to tutorial information about creating different roof styles automatically. Click on a roof style to launch the online Help to a page with information about the roof style you selected. See “Roof Tutorial” on page 69 of the User’s Guide.

Roof Planes

When creating a roof, it is helpful to know how to draw a roof plane manually and be familiar with its parts.

Drawing Roof Planes



Roof planes are CAD-based objects that are created and edited like much closed polylines, and also have pitch, elevation and structural properties.

Before drawing roof planes, you should set your roof defaults so that the 3D attributes of your roof planes are correct. See “Roof Defaults” on page 351.

To draw a roof plane

1. Select **Build> Roof> Roof Plane** .
2. As in the following example, click and drag a Baseline from point **1** to point **2**.



Line 1 - 2 is the Baseline

3. Release the mouse button at point **2** and move your cursor in the upslope direction. As you move the cursor, a preview outline of the roof plane displays.
4. Click at point **3** to build the roof plane. Point 3 is located on the ridge edge of the roof plane.

Note: You cannot manually draw roof planes when Auto Rebuild Roofs is enabled in the Build Roof dialog. See “Roof Tab” on page 356.

The **upslope mark** displays at the center point of the Baseline and indicates the upslope direction of the roof plane.

The distance from the outer main layer of the wall to the end of the eave is the **overhang**.

The Baseline

The pitch direction and initial height of any roof plane - manual or automatic - is determined by its Baseline.

The Baseline of the roof plane is normally located over the outer main layer of the wall and is used as the pivot point for the roof plane when the pitch is changed.

The Baseline height is determined by the following formula:

$$\begin{aligned}
 & \text{Elevation of the wall top plate} \\
 & + \text{Vertical Rafter Depth} \\
 & - \text{Vertical Birdsmouth Depth} \\
 & = \text{Baseline Height}
 \end{aligned}$$

In a cross section, the Baseline is located directly above the outer surface of the main wall layer, at the top surface of the roof framing.

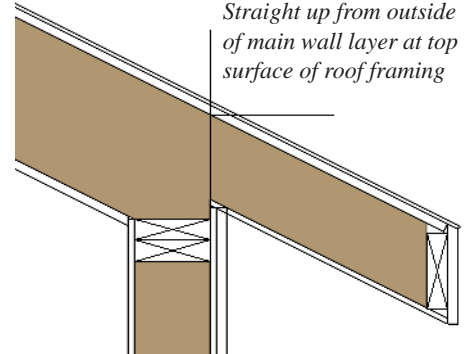

Location of Roof Baseline in cross-section

A roof Baseline displays as a separate line within its roof plane when the “Roofs, Baselines” layer is turned on. In 3D views, it can only be seen if the roof plane is selected.

A Baseline has a tick mark at its center point which indicates the direction that the roof plane slopes upward. If the upslope tick is pointing the wrong direction, either rotate the entire roof plane or delete it and draw a new one.

When drawing the Baseline of a roof plane, here are some things to consider:

- A Baseline does not have to be drawn over a wall, although it often is.
- A Baseline drawn along a wall should be drawn over the outer edge of the wall’s main layer. It tries to snap to that layer.
- The elevation of the top plate is defined by the ceiling height in the room. If the roof plane is not drawn over a wall, it’s height is based on the default ceiling height value for the current floor.
- If a Baseline is drawn over the top of any other roof plane, the Baseline height equals the height of the existing roof

plane at the point where you started drawing.

Once drawn, a Baseline can be selected in floor plan view and edited independent of the roof plane. See “Editing Roof Baselines” on page 369.

Eave and Gable Overhangs

Roof overhangs are measured horizontally from the outside Main Layer of exterior walls to the end of the top of the rafter. They include fascia but not gutters. See “The Main Layer” on page 209.

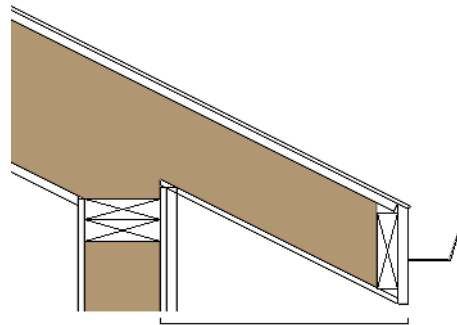

Roof Overhang measured horizontally from the wall's Main Layer to outside of the fascia

The location of a roof plane's fascia and shadow boards also determines its area and the size of its polyline in floor plan view. See “Polyline Tab” on page 374.

Displaying Roofs



Roof planes are drawn on the “Roof Planes” layer.

You can also choose to display gutters, gable lines, the overhang area, Roof Baseline Polylines and roof openings. See “Layer Display Options Dialog” on page 104.



If the “Roof Planes” layer is turned off and **Auto Rebuild Roofs** feature is turned on, changes made to the plan that cause the roof to rebuild will not automatically turn on the display of the roof planes. See “Rebuilding Roofs” on page 355.

Roof Plane Labels

Roof plane labels indicating the pitch and slope direction are located on the “Roofs, Labels” layer and can be set to display in floor plan view.

You can specify whether roof plane labels display the pitch in terms of rise and run or in decimal degrees by checking or unchecking **Pitch in Degrees** in the **Roof Plane Specification** dialog. See “General Tab” on page 372.

A roof plane's label can be customized in its specification dialog. See “Label Tab” on page 885.

Manually drawn **Ceiling Planes**  and **Skylights**  can also display labels when the “Roofs, Labels” layer is on. Unlike roof planes, these objects' do not include a slope indicator and their Automatic Labels are blank; however, you can specify a custom label using text in their specification dialogs. See “Ceiling Planes” on page 379 and “Skylights” on page 385.

When a roof plane, ceiling plane or roof hole/skylight is selected in a 3D view, its label will display on a temporary basis if the “Roofs, Labels” layer is turned on.

Display on Floor Above/Below



In floor plan view, roof planes can display on any floor without affecting their height in 3D.

To move the display of a roof plane to a new floor, select it in floor plan view and click either the **Display on Floor Above** or **Display on Floor Below** edit button. The display of group-selected roof planes can also be controlled in this manner.

Any skylights or roof holes placed in a roof plane moved in this manner will move, as well. Other associated objects like Auto Dormers or gutters will not move, however.

In Cross Section Views

When a roof or ceiling plane is viewed in a cross section, the layers that compose it can be seen, including the roof surface, sheathing, and the ceiling surface.

- If roof framing has been built, it's display can be turned on, as well. See “Displaying Framing” on page 458.
- If a roof or ceiling plane is located over a room with **Ceiling Over this Room** checked, the ceiling surface will not generate. See “Vaulted and Cathedral Ceilings” on page 242.

In the Materials List

The materials that make up roof and ceiling plane assemblies are listed under different Categories in the Materials List:

- **Roofing** - Lists most materials associated with roofs, including roofing, sheathing, rafters and trusses, gutters, and skylights.
- **Insulation** - Insulation is calculated for roof and ceiling planes above rooms that do not have Ceiling Over This Room checked. See “Structure Tab” on page 245.
- **Wallboard** - Lists ceiling materials for all rooms, including those that use the underside of the roof as their ceiling.
- **Framing** - Lists ceiling framing for manually drawn ceiling planes.

See “Materials Lists” on page 887.

Editing Roof and Ceiling Planes

A selected roof or ceiling plane can be edited in 2D and 3D using edit handles, edit toolbar buttons, its specification dialog, and the

Material Painter .

A roof or ceiling plane's Baseline can also be selected and edited. To select it, first select the roof plane and then click the **Select Next**

Object  edit button. See “The Baseline” on page 363.

By default, all roof planes are deleted and replaced whenever the roof is rebuilt using the **Build Roof** dialog. If you have manually edited roof planes and do not want them to be

replaced, be sure to check **Retain Edited Roof Planes**. See “Roof Tab” on page 356.

 Roof planes cannot be edited while Auto Rebuild Roofs is turned on. If you try to do so, the program will prompt you to turn it off.

2D Shape and 3D Orientation

There are two basic aspects to editing roofs: 2D shape and 3D orientation.

- The 2D shape of a roof or ceiling plane can be edited just like a CAD polyline. As a plane is reshaped in 2D, the program maintains its height and pitch in 3D. See “Editing Closed-Polyline Based Objects” on page 138.
- The 3D orientation of a roof or ceiling plane is defined by its height and pitch and can be edited in its specification dialog. See “General Tab” on page 372.

An understanding of these two concepts allows you to design almost any kind of roof.

A roof or ceiling plane’s display and appearance can be customized. See “Displaying Roofs” on page 364 and “Roof Plane Specification Dialog” on page 371.

Adding a Step to an Edge

You can make a step, or jog, in the edge of a roof or ceiling plane by selecting it, clicking the **Break Line**  edit button and then clicking on the roof edge. See “Break Line” on page 158.

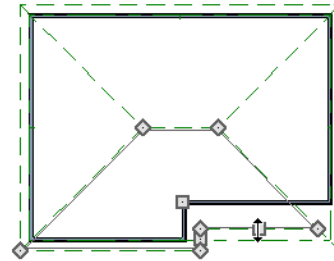

Aligning Roof Edges

By default, the edges of a roof plane will automatically snap to the outer surface of a nearby parallel wall. You can disable this **Special Snapping** behavior for a selected roof plane in its specification dialog. See “General Tab” on page 372.

After moving a corner edit handle, it may be difficult to make an edge parallel to an eave or a wall. Use the **Make Parallel/**

Perpendicular  edit button to align a roof or ceiling plane edge with a wall, another roof plane edge, or another object with a straight edge. See “Using Make Parallel/Perpendicular” on page 155.

 If opposite sides of a roof plane are parallel, Temporary Dimensions will display between them when one side is selected.

Sometimes, what appears to be a single, straight roof plane edge may actually be broken into two or more edges, which can affect your ability to align the edge properly.

A single edge will have three edit handles; if more than three display, more than one edge is present. An extra handle can be removed

removed manually by dragging it into an adjacent handle. You can also use **Build> Roof> Fix Roofs** . See “Fix Roofs” on page 353.

When **Bumping/Pushing**  is enabled and **CAD Stops Move** is checked in the **Roof Plane Specification** dialog, a roof plane will bump against another roof plane, CAD or CAD based object as it is moved. Roof planes cannot push these objects, however. See “Bumping/Pushing” on page 152.

Join Roof Planes

 Two roof or ceiling planes can be joined at adjacent edges in both 2D and 3D using the **Join Roof Planes** edit button. To use this tool, first identify which edges of the roof planes can extend to meet at a ridge, hip, or valley. The program will join the two planes along the line where they intersect whenever possible.

To use Join Roof Planes

1. Select a roof or ceiling plane on the edge to be joined to another plane.
2. Click the **Join Roof Planes**  edit button (or press 2 on the keyboard).
3. Move your pointer to the edge of the second roof or ceiling plane that the first one needs to join to. When your pointer is over the second plane, this plane will highlight.
4. Click on the edge of the second roof or ceiling plane to join it to the first plane.

Note: Join Roof Planes cannot be used to join a roof plane and ceiling plane. Only planes of the same type can be joined using this tool.

If the planes are not close enough, or their shape is not correct, you may need to align their edges, remove extra edges, or move them closer.

When roof or ceiling planes adjust, the program joins them at the proper location and the adjacent edges extend or contract to remain connected. If the joining of the two will completely eliminate or reverse an adjacent edge, the connection cannot be made.

Locating Intersections

When roof planes of differing slopes meet, they create a ridge, hip, or valley. The **Join Roof Planes**  edit tool is the easiest way to move roof plane edges so that they meet correctly; but you can also locate roof plane intersection points where the ridge, hip or valley should be. Once you know where the planes will meet, you can drag edges or corners to those points.

To find roof plane intersection points

1. Make sure that **Automatically Place Roof Intersection Points** is turned on in the **Preferences** dialog. See “Architectural Panel” on page 73.
2. Select the roof plane you would like to place intersection points on.
3. Click the edge of another roof plane to place a temporary CAD Point where it would meet the selected roof plane.

- Repeat steps 1 and 2 for the ridge edge and both fascia edges. You should have three points located on the larger roof plane: these are the intersection points.

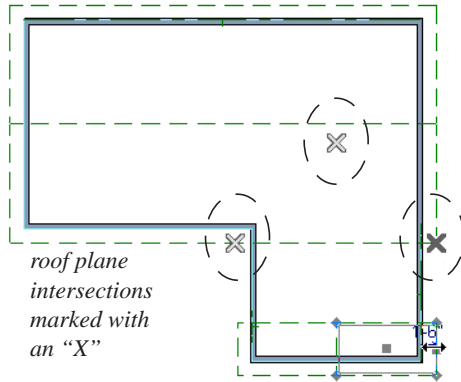

- Once these intersection points are identified, you can snap the corners of the second roof plane to them.

Aligning Eaves

It is not uncommon for roof plans to feature more than one pitch. In order for the eaves of roof planes with different pitches to meet correctly at ridges and hips, you must control the roof planes' heights and their horizontal overhang distances. Two options in the **Build Roof** dialog allow you to control how the eaves of automatically generated roof planes align. See "Roof Tab" on page 356.

- Same Roof Height at Exterior Walls** maintains the default height of roof planes where they bear on exterior walls. The horizontal overhang distances of any non-default roof planes are adjusted so that they continue to join correctly with default roof planes.
- Same Eave Heights** maintains the default roof plane height at the eaves as well as

any non-default horizontal overhang distances. All roof planes are raised or lowered so that they all have the same height at the eaves as default roof planes.

Roof planes that do not join other roof planes with different pitches at ridges or hips are referred to as Independent.

- When **Same Roof Height at Exterior Walls** is checked, Independent roof planes are not affected and will maintain any non-default overhang values.
- When both **Same Roof Height at Exterior Walls** and **Same Eave Heights** are checked, the overhangs of Independent roof planes will be adjusted to preserve their heights at both the exterior walls and the eaves.

Move to be Coplanar



The **Move to be Coplanar** edit button allows you to move the selected roof plane to be coplanar (in the same plane) with the next selected roof plane. You can use this tool in both 2D and 3D views. The results can be easily seen in a cross section view. The two roof planes must have parallel Baselines for this to work.

Raising/Lowering Roof Planes



Roof planes can be raised or lowered in the **Roof Plane Specification** dialog. Begin by locking the **Pitch**, then change the value of the **Baseline Height**. See "General Tab" on page 372.



You can also raise or lower roof planes in the **Transform/Replicate Object** dialog. See "Transform/Replicate Object Dialog" on page 166.

In addition, when a new floor is added to a plan, you can choose to move any roof planes displaying on the top floor up one floor. See “Adding Floors” on page 317.

Change Roof Pitch or Height Dialog

The **Change Roof Pitch or Height** dialog displays when you attempt to snap the corner or an edge of a roof plane near the edge of another roof plane that does not match vertically. This dialog gives you the option to move the roof plane vertically, or pivot it about a point and change the pitch.

In this case, the current roof plane would have to raise its pitch or height in order to meet the second roof plane at the corner that you moved.



The amount of vertical displacement between the selected roof plane and another nearby roof plane is stated at the top left.

- Click on **Pivot About Eave** to maintain the current eave height and modify the baseline and ridge heights and pitch to meet the other roof plane. Not available when the selected corner is associated with the eave edge.
- Click on **Pivot About Baseline** to maintain the current baseline height and modify the eave and ridge heights and pitch to

meet the other roof plane. Not available when the selected corner is associated with the baseline.

- Click on **Pivot About Ridge** to maintain the current ridge top height and modify the eave and baseline heights and pitch to meet the other roof plane. Not available when the selected corner is associated with the ridge edge.
- Click on **Raise/Lower (no pivot)** to maintain the current pitch and raise or lower the entire plane to connect the roofs. This may affect plate heights of the walls below.
- Click on **None of the Above** to close the dialog without making any changes to the selected roof plane.

To prevent this dialog from displaying, check **Don't show again during this session**. The dialog does not display again until you have terminated and restarted the program.



Unless you have a specific reason to adjust the roof plane this way, it is usually best to select None of the Above.

Editing Roof Baselines

The pitch direction and initial height of any roof plane - manual or automatic - is determined by its Baseline. See “The Baseline” on page 363.

In floor plan view, a Baseline can be selected and edited independent of the roof plane. To select it, click on the roof plane at the location of the Baseline and then click the

Select Next Object  edit button. The Status Bar tells you when the roof plane

Baseline is selected. See “Select Next Object” on page 126.

If a roof plane Baseline is moved, its height will not change. Instead, the height of the roof plane will be affected. In most cases, therefore, moving a roof plane’s Baseline independent of the roof plane itself is not recommended.

If the angle of a roof plane’s Baseline is changed, the direction of the roof plane’s pitch will be modified. The Baseline Angle can be modified in either of two ways:

- In the **Roof Plane Specification** dialog. This will change its angle relative to the floor, and will tilt the roof plane along an axis perpendicular to its Baseline. This method is helpful when a specific eave angle is needed. See “General Tab” on page 372.
- Using its Rotate edit handle in floor plan view. This will change its angle relative to the roof plane’s eave or ridge and will modify the direction of the pitch. This method is best when the pitch direction matters more than the angle of the eave.
- Both of these methods can be used to modify the same roof plane, although the second approach makes it difficult to control both the pitch direction and eave angle, and is not recommended.

The length of a roof plane Baseline can be lengthened or shortened using its edit handles without changing any of the roof plane’s attributes.

Set Baseline Height Dialog

If you manually draw a roof plane so that it bears on a wall at its Baseline, and is placed in the same location as an existing roof

plane, the **Set Baseline Height** dialog will display. See “The Baseline” on page 363.

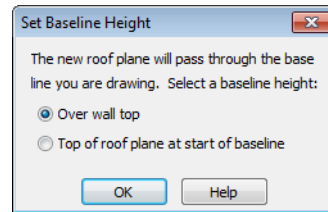

- Select **Over wall top** to create a roof plane that bears on the wall it is drawn over and has an overhang as specified in the **Build Roof** dialog. This option would be appropriate to produce a full height dormer. See “Manually Drawn Dormers” on page 389.
- Select **Top of roof plane at start of baseline** to produce a roof plane with a height based on that of the roof plane below it rather than the wall. The Baseline height equals the top height of the existing roof at the point where you began drawing the new roof plane Baseline, and has no overhang. This option would be appropriate to create a dormer vent or cricket. See “Manually Drawn Crickets” on page 390.

Editing Roof Plane Structure

To create roof planes of a particular depth, begin by setting up the desired roof framing defaults, then build the roof. See “Framing Defaults” on page 436.

If you later need to change the structure of the roof planes, make the needed change to the Framing Defaults, and then rebuild the roof. You can also edit roof structure on an individual roof plane basis. See “Roof Plane Specification Dialog” on page 371.

Birdsmouth Cut

The birdsmouth is the notch cut into a rafter where it rests on the wall top plate. You can control its vertical depth and the width of the birdsmouth seat in the **Build Roof** dialog. See “Roof Tab” on page 356.

There are two ways to create a roof plane with no birdsmouth:

- Check **Trusses (No Birdsmouth)** in the **Build Roof** dialog before drawing the roof plane.
- Specify a **Raise Off Plate** value of at least 1/16” in the **Build Roof** dialog.

To change the birdsmouth depth after the roof is built, you can move the roof planes up or down, or change the pitch. For example, if you lock the pitch and raise the roof plane by one inch, you decrease the birdsmouth depth by one inch.

Locking Roof Planes

When the roof plan is correct, roof planes can be locked to prevent accidental changes. To do this, lock the “Roof Planes” layer. See “Layer Display Options Dialog” on page 104.

Locking roof planes will not prevent roof planes from being deleted if the floor they are on is deleted.

Deleting Roof Planes

There are several ways to delete roof planes.



Delete the entire roof quickly by selecting **Build > Roof > Delete Roof Planes**.



You can also delete all roof planes at once in the **Delete Objects** dialog. See “Delete Objects Dialog” on page 171.

In addition, you can select any roof plane or group of roof planes, then press the Delete key or click the **Delete**  edit button to delete it from the plan. See “Deleting Objects” on page 171.

Generally speaking, roof planes cannot be deleted if they are locked. An exception to this rule occurs when an entire floor of a plan is deleted. Any roof planes present on a floor will be deleted when the floor is deleted, locked or not. See “Deleting Floors” on page 320.

Roof Plane Specification Dialog



Select one or more roof planes and click the **Open Object** edit button to open the **Roof Plane Specification** dialog.

General Tab

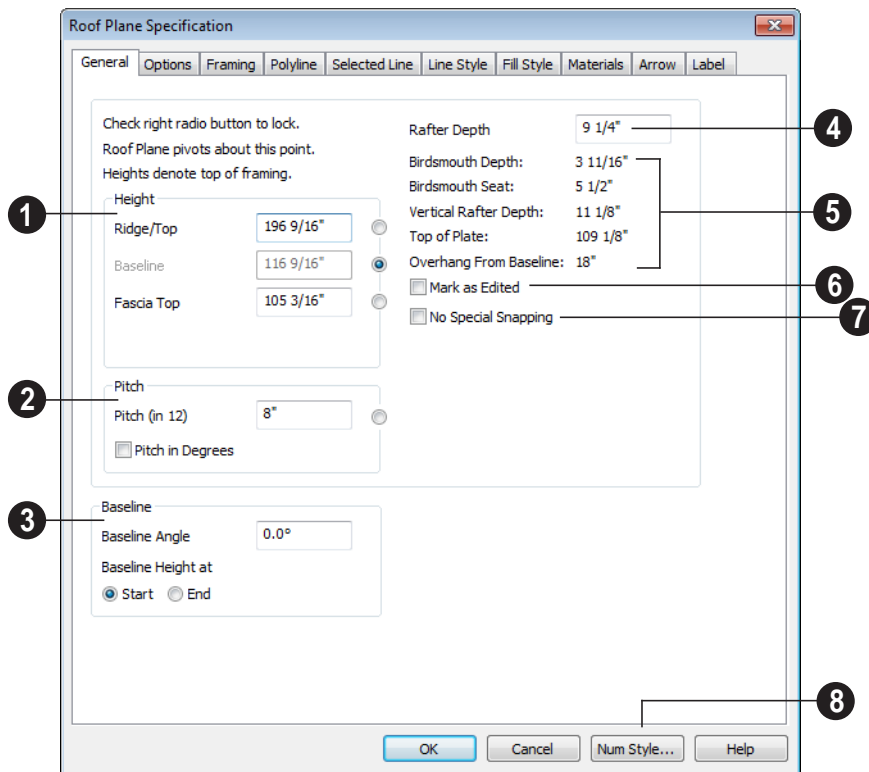

There are four values that define the 3D orientation of a roof plane: **Ridge/Top Height, Baseline Height, Fascia Top Height** and **Pitch**.

Locking any of the **Height** values defines that value as the pivot point for the selected roof plane. Each of these dimensions is measured from the first floor default elevation of 0' - 0".

If you lock the **Pitch** and change a Height value, the roof plane moves vertically, keeping the same slope. It will not pivot. For a conversion to degrees, see "Roof Pitches in Degrees" on page 395.

Changing these values does not affect the 2D representation of the roof plane.

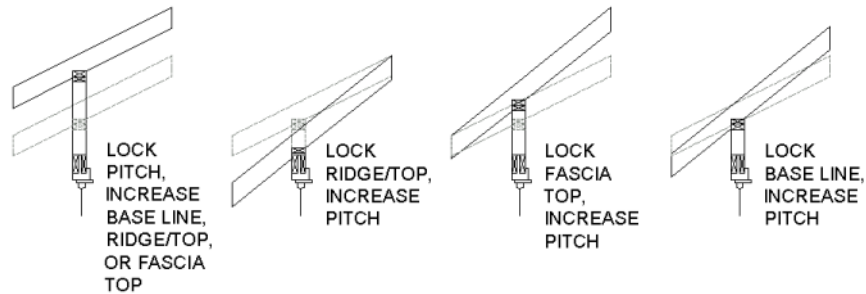

- 1 Specify the **Height** of the selected roof plane(s).
 - Define the **Ridge/Top** height of the selected roof plane, or lock this value to make it the roof plane's pivot point.
 - Define the **Baseline** height, or lock this value to make it the pivot point.
 - Define the **Fascia Top** height, or lock this value to make it the pivot point.
- 2 Specify the **Pitch** for the selected roof plane. Lock the Pitch to move the roof plane vertically when a Height value is changed.
 - Check **Pitch in Degrees** to display the pitch value in this dialog in degrees in this dialog and in roof plane labels. Values between -80° and 80° can be entered.
 - When **Pitch in Degrees** is unchecked, Pitch is described in terms of rise and run: x inches in 12 in Imperial plans and x mm in 1000 in metric plans.
- 3 Specify the angle of the selected roof plane's **Baseline**, relative to the XY axis. See "Editing Roof Baselines" on page 369.
 - A positive **Baseline Angle** value causes the Baseline to tilt upward from its default

height. A negative value causes it to tilt downward. The top heights of any walls under the selected roof plane will become angled, as well.

- The **Baseline Height** defined above can be maintained at either the **Start** or **End** point. In floor plan view, the Baseline direction is clockwise around the house.
- 4 Specify the **Rafter Depth** for the selected roof plane. The default rafter depth is set in the **Build Framing** dialog. See "Build Framing Dialog" on page 443.
 - 5 Information about the structure of the selected roof plane(s) displays here for reference.
 - The **Birdsmouth Depth** is the plumb or vertical depth of the birdsmouth cut. To change it, move the roof plane some way. For example, if you lock the pitch and raise the roof plane by one inch, you will decrease the birdsmouth depth by one inch. See "Birdsmouth Cut" on page 371.
 - The **Birdsmouth Seat** is the horizontal width of the birdsmouth cut. This value is dynamically linked to the birdsmouth depth - if one changes, so does the other.
 - The **Vertical Rafter Depth** is defined by measuring a plumb line across the rafter.

The degree of pitch affects the Vertical rafter width. The greater the pitch, the greater the vertical rafter depth.

- **Top of Plate** is defined by the ceiling height for the room.
- **Overhang from Baseline** is the horizontal overhang measured from the Baseline to the eave.

6 Mark as Edited - When an automatic roof plane is moved or reshaped, the program marks it as "edited". You can check **Retain Edited Roof Planes** in the **Build Roof** dialog to prevent these marked planes from being deleted when the roof is rebuilt. Checking **Mark as Edited** also marks an automatically generated roof plane from being replaced, even if it has not been edited. Edited planes can also be unmarked.

This option is only available for automatically generated roof planes. If a manually drawn roof plane is selected, the words **Manual Roof Plane** will display here instead.

7 Check No Special Snapping to prevent the selected roof plane from snapping to the outer surface of any walls that it may butt against. When this box is unchecked, the roof plane's edges will automatically snap to the outside of any nearby parallel walls.

8 Click the Num Style button to change the way numbers display in the dialog. See "Number Style/Angle Style Dialog" on page 89.

Options Tab

The settings on the Options tab are the same as those on the tab of the same name in the **Build Roof** dialog, but affect the selected

roof plane only. See "Options Tab" on page 360.

Framing Tab

The settings on the Framing tab are the same as those on the Roof tab of the **Build Framing** dialog, but apply to the selected roof plane only. See "Roof Tab" on page 451.

Polyline Tab

The Polyline tab indicates the length of the roof plane's **Perimeter** and its enclosed **Area**, calculated using several different methods.

Roof Plane Specification		
General	Options	Framing
Polyline	Selected Line	Lin
Perimeter	528 7/16"	
Framing Area	120.185 sq ft	
Projected Area	100 sq ft	
Roof Surface Area	123.208 sq ft	
Overhang Area	120.091 sq ft	
Projected Overhang Area	100 sq ft	

Perimeter - This is the length of the roof plane's perimeter, including fascia, with its pitch taken into account. It does not equal the perimeter as measured in floor plan view unless the pitch is 0.

Framing Area - This is the area of the roof plane's framing, not including the fascia, with the pitch taken into account. It is slightly smaller than the Roof Surface Area

as roofing typically overhangs the framing by a small amount.

Projected Area - This is the area of the roof plane polyline, including fascia, as seen in floor plan view. It does not equal the Roof Surface Area unless the pitch is 0.

Roof Surface Area - This is the area of the roof plane's top surface, which covers the fascia, with the pitch taken into account.

Overhang Area - This is the area of the roof plane's overhang, including fascia, with its pitch taken into account.

Projected Overhang Area - This is the area of the roof plane's overhang, including fascia, as seen in floor plan view.

Selected Line Tab

The Selected Line tab is similar to the Line tab of the **Line Specification** dialog. See "Line Tab" on page 780.

Line Style Tab

For information about the settings on this tab, see "Line Style Tab" on page 781.

Fill Style Tab

The settings on the Fill Style tab control the appearance of the selected roof plane in floor plan view. For information about these settings, see "Fill Style Tab" on page 792.

Materials Tab

The settings on the Materials tab allow you to specify materials for the selected roof plane's various components. For more information, see "Materials Tab" on page 635.

The "Ceiling Surface" component is only available when **Use Room Ceiling Finish** is unchecked and **Has Ceiling** is checked on the Options tab.

Label Tab

Roof plane labels display when the "Roofs, Labels" layer is turned on and use the Text Style assigned to that layer. See "Roof Plane Labels" on page 364.

For information about the settings on this tab, see "Label Tab" on page 885.

Roof Baseline Polyline

Typically, the program builds an automatic roof based on the settings in the **Build Roof** dialog and on the Roof tab of the **Wall Specification** dialog, along with the layout of the exterior walls and floor and ceiling heights.

If you want to build a roof that diverges from the footprint of your building as well as the roof directives in the exterior walls, you can use Roof Baseline Polyline.

To create roof baseline polylines

1. Select **Build> Roof> Build Roof** .
2. On the Build tab of the **Build Roof** dialog, check **Make Roof Baseline Polyline**.
3. Click **OK**. A set of roof Baselines is created along the outside edge of the Main Layer of the exterior walls, forming one or more closed polylines.

As with roof planes, the heights of Roof Baseline Polyline(s) are determined by ceiling heights in the plan. If roof planes will be built at more than one height, a separate baseline polyline is created for each height.

Once created, a Roof Baseline Polyline can be edited in a variety of ways, then used as the basis for the roof then next time it is built automatically.

To create a new roof using the directives in your Roof Baseline Polyline(s), check **Use Existing Roof Baselines** in the **Build Roof** dialog and click OK. See “Roof Tab” on page 356.

Displaying Roof Baseline Polyline(s)

Roof Baseline Polyline(s) are placed on the “Roofs, Baseline Polyline(s)” layer and use the Text Style assigned to that layer. See “Displaying Objects” on page 102.

Roof directive information displays along each edge of the polyline, including:

- **V** - vertical (against wall);
- **G** -gable/shed;
- **K** - knee wall;
- **L** - lower (extend slope downward).

If the directive information includes the pitch, the roof plane slopes toward that edge; if it includes the word (vert), it does not.

Editing Roof Baseline Polyline(s)

A Roof Baseline Polyline’s shape can be edited much like a CAD polyline using its edit handles and edit toolbar buttons. See

“Editing Closed-Polyline Based Objects” on page 138.

Roof Baseline Polyline(s) always form a closed area with straight sides only. They cannot be severed or curved, but additional joints or corners can be added.

When a new roof is built, it follows the shape of the Roof Baseline Polyline even if that shape does not follow the exterior walls.

In addition to length and direction, each Roof Baseline Polyline edge has roof directives associated with it, much like the roof directives in individual walls. See “Roof Directives in Walls” on page 204.

An Example

For a simple example of Roof Baseline Polyline editing, consider an L-shaped house, with a rectangular roof. The inner part of the ‘L’ is a patio that is covered under the same roof.

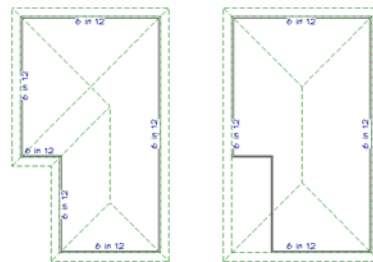

On the left is the baseline polyline as it was originally produced and the roof plan it creates.

To model the roof plan shown on the right

1. Select the Roof Baseline Polyline along its bottom-most edge.

- Click the **Fillet Two Lines**  edit button. See “Reshaping Objects” on page 158.
- Click the left-most edge to remove the two intervening edges.
- A message box informs you that “The system must delete intervening lines (those on the inside of the L) to join the two selected lines.” Click OK.
- Open the **Build Roof** dialog and select the **Build Roof Planes** and **Use Existing Roof Baseline** check boxes to model the roof plan shown on the right side of the image above.

Roof Baseline Specification Dialog



Like walls, each line of a Roof Baseline Polyline contains roof directives that affect automatic roof generation. Select any edge of a Roof

Baseline Polyline click the **Open Object** edit button open the **Roof Baseline Specification** dialog.

Roof Baseline Tab

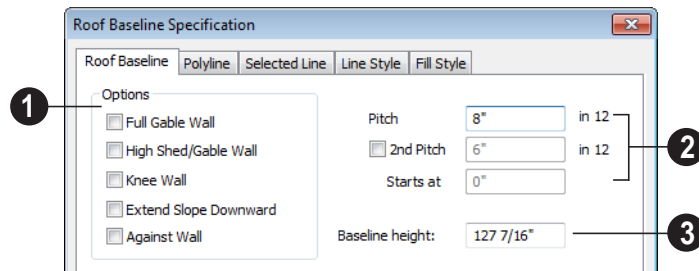

1 Options -

The first four checkboxes: **Full Gable Wall**, **High Shed/Gable Wall**, **Knee Wall**, and **Extend Slope Downward** are the same as those in the **Wall Specification** dialog. See “Roof Tab” on page 218.

Check **Against Wall** if the roof plane rising from this baseline butts against an exterior wall. This is similar to checking High Shed/Gable Wall.

2 Specify the **Pitch** for the selected edge of the Roof Baseline Polyline. This overrides the default pitch set in the **Build Roof** dialog. See “Build Roof Dialog” on page 355.

The **Pitch**, **2nd Pitch**, and **Starts at** settings are the same those in the **Wall Specification** dialog.

3 **Baseline height** - This is the height of the entire Roof Baseline Polyline, not just that of the selected edge. See “The Baseline” on page 363.

Polyline Tab

The Polyline tab indicates the length of the Roof Baseline Polyline's **Perimeter**, its enclosed **Area**, and its **Volume**.

Selected Line Tab

This tab is similar to the Line tab of the **Line Specification** dialog. See "Line Tab" on page 780.

Line Style Tab

For information about the settings on this tab, see "Line Style Tab" on page 781.

Fill Style Tab

The settings on the Fill Style tab control the appearance of the selected Roof Baseline Polyline in floor plan view. For information about these settings, see "Fill Style Tab" on page 792.

Roof and Ceiling Framing

Roof framing can be both drawn manually and generated automatically. You can also combine the two techniques. As with other kinds of framing, it is often easiest to begin by generating roof framing automatically and then editing it as needed. See "Manual vs. Automatic Framing" on page 437.

Roof Trusses  cannot be generated automatically - they must be drawn manually and then replicated. If you intend to use Roof Trusses, make sure the settings in the **Build Roof** dialog are properly defined before you build the roof. See "Roof Trusses" on page 470.

When using a combination of Roof Trusses and stick framing, begin by drawing the roof planes and ceiling planes. When they are in place, draw and replicate the Roof Trusses. Finally, automatically generate or manually draw the stick framing and edit it as needed. See "Mixing Rafters and Trusses" on page 439.

Framing for manually drawn **Ceiling**

Planes  cannot be drawn manually - it must be automatically generated. The framing for manually drawn Ceiling Planes is generated when ceiling framing is built and uses the settings in the **Build Roof** dialog as defaults. Once it has been created, it can be edited. See "Ceiling Plane" on page 352.

Rebuilding Roof Framing

If roof framing defaults are modified after the roof and roof framing are built, neither will update automatically. In order to update the model you need to rebuild the roof, then rebuild the roof framing.

You can also modify the roof framing settings for individual roof planes, and then either build roof framing or manually redraw the framing for just those planes. See "Framing Tab" on page 362.

See "Keeping Framing Current" on page 461.

Ceiling Planes



Ceiling planes are drawn the same way as roof planes and are edited using the same tools. They are useful for creating custom vaulted ceilings. See “Vaulted and Cathedral Ceilings” on page 242.

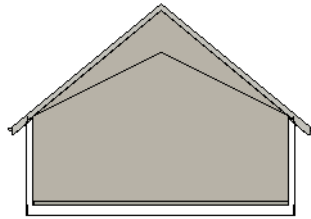
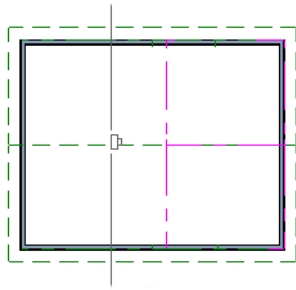



Cross Section showing ceiling planes.

Ceiling planes are drawn using the same pitch as roof planes, specified in the **Build Roof** dialog. See “Build Roof Dialog” on page 355.

If you wish, you can specify the desired pitch in the **Build Roof** dialog before drawing a ceiling plane, or you can change the pitch after it is drawn in the **Ceiling Plane Specification** dialog. See “Ceiling Plane Specification Dialog” on page 380.

There are a few things to remember when drawing ceiling planes.

- Ceiling planes should be created over rooms that have **Ceiling Over this Room** unchecked in the **Room Specification** dialog. See “Structure Tab” on page 245.
- The Baseline of a ceiling plane should be drawn along the outer surface of the bearing wall’s Main Layer. This allows the ceiling plane to extend over and be supported by the wall. See “The Main Layer” on page 209.
- The sloping edge at the side of a ceiling plane should butt to the inside of the wall.
- Ceiling planes act independent of the roof planes above.
- Usually, the pitch of a ceiling plane is lower than the pitch of the corresponding roof plane.
- Ceiling planes can be joined together using the **Join Roof Planes**  edit button. See “Join Roof Planes” on page 367.
- Select a ceiling plane and click the **Open Object**  edit button to open the **Ceiling Plane Specification** dialog. See “Ceiling Plane Specification Dialog” on page 380.

Displaying Ceiling Planes



Ceiling planes are drawn on the “Ceiling Planes” layer.

Manually drawn **Ceiling Planes**  can also display labels when the “Roofs, Labels” layer is on. See “Roof Plane Labels” on page 364.

Editing Ceiling Planes

Ceiling planes can be edited much like roof planes using their edit handles and edit toolbar buttons. See “Editing Roof and Ceiling Planes” on page 365.

Ceiling planes can also be edited in the **Ceiling Plane Specification** dialog. See “Editing Roof and Ceiling Planes” on page 365.

As with roof planes, the ceiling planes layer can be locked to prevent editing.

Deleting Ceiling Planes

Select **Build> Roof> Delete Ceiling Planes** to delete all ceiling planes in the current plan.

 Ceiling planes can also be deleted at once in the **Delete Objects** dialog. See “Delete Objects Dialog” on page 171.

In addition, you can select any ceiling plane or group of ceiling planes, then press the

Delete key or click the **Delete**  edit button to delete it from the plan. See “Deleting Objects” on page 171.

Ceiling Plane Specification Dialog



Select a ceiling plane and click the **Open Object** edit button to open the **Ceiling Plane Specification** dialog.

The **Ceiling Plane Specification** dialog is similar to the **Roof Plane Specification** dialog. See “Roof Plane Specification Dialog” on page 371.

General Tab

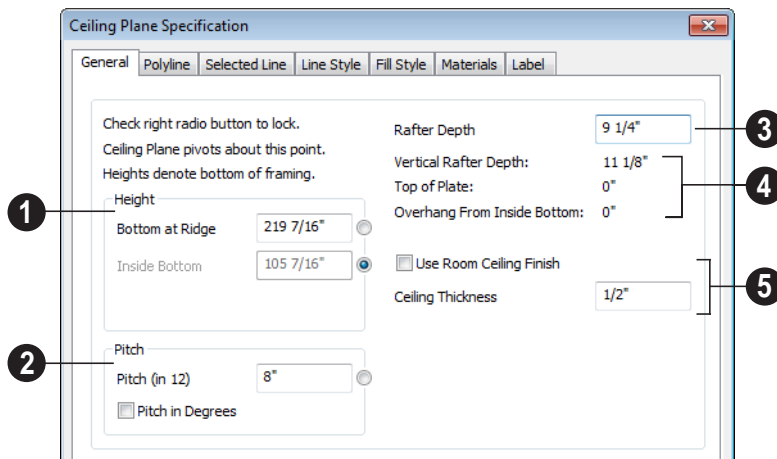

There are four values that define the 3D orientation of a ceiling plane: **Bottom at**

Ridge, Inside Bottom, Outside Bottom and **Pitch**.

Locking any of the **Height** values defines that value as the pivot point for the selected ceiling plane. Each of these dimensions is measured from the first floor default elevation of 0' - 0".

If you lock the **Pitch** and change a Height value, the ceiling plane moves vertically, keeping the same slope. It will not pivot.

Changing these values does not affect the 2D representation of the ceiling plane.

1 Specify the **Height** of the ceiling plane.

- **Bottom at Ridge** - Set the highest point on the underside of the ceiling plane.
- **Inside Bottom** - Set the underside height at the lowest point on the ceiling plane. If the plane is drawn over a wall, this is located at the inside surface of the wall's Main Layer.
- **Outside Bottom** - Only available when a ceiling plane is drawn over a wall, this is the height of the lower edge of the ceiling rafters, were they not clipped by the wall below.

2 Specify the **Pitch** of the selected ceiling plane. For a conversion to degrees, see "Roof Pitches in Degrees" on page 395.

- Check **Pitch in Degrees** to display the Pitch value in degrees.

3 **Rafter Depth** - Specify the rafter depth for the selected ceiling plane. The default rafter depth is the same as that for roof planes and is set in the **Build Framing** dialog. See "Build Framing Dialog" on page 443.

4 Information about the selected ceiling plane's structure displays here for reference.

- **Vertical Rafter Depth** - This is defined by measuring a plumb line through a rafter. The greater the pitch, the greater the vertical rafter depth.
- **Top of Plate** - This is the top plate height of the bearing wall, which also defines the ceiling height of the room.
- **Overhang From Inside Bottom** - Only appearing when a ceiling plane is drawn over a bearing wall, this is the horizontal distance from the Baseline to the inside Main Layer surface of the wall. The Baseline is typically drawn over the outside Main Layer surface, so this value is equal to the wall's Main Layer thickness.
- **Clip End** - Only available when a ceiling plane is drawn over a bearing wall, this is the amount a ceiling rafter's underside must be clipped at its lower end to rest on the wall top plate. This is equal to the ceiling plane's rise in slope over the distance of the **Overhang from Inside Bottom**.

The **Outside Bottom** value plus the **Clip end** value equals the **Top of Plate** value.

5 When **Use Room Ceiling Finish** is checked, the selected ceiling plane's ceiling finish thickness and material are defined by the room below and the "Ceiling Surface" component will not be available on the Materials tab. Uncheck this box to enable the **Ceiling Thickness** option.

- Specify the **Ceiling Thickness**, which is the thickness of the bottom surface of the ceiling plane.

Polyline Tab

The Polyline tab indicates the the ceiling plane's **Perimeter**, its **Framing Area**, and its **Projected Area**. See "Polyline Tab" on page 374.

Selected Line Tab

This tab is similar to the Line tab of the **Line Specification** dialog. See "Line Tab" on page 780.

Line Style Tab

For information about the settings on this tab, see "Line Style Tab" on page 781.

Fill Style Tab

The settings on the Fill Style tab affect the appearance of the selected ceiling plane in

floor plan view. For information about these settings, see "Fill Style Tab" on page 792.

Materials Tab

The "Ceiling Surface" component is only available when **Use Room Ceiling Finish** is unchecked on the General tab.

For more information about the settings on this tab, see "Materials Tab" on page 635.

Label Tab

Ceiling plane labels display when the "Roofs, Labels" layer is turned on and use the Text Style assigned to that layer. The Automatic Label for ceiling planes is blank, but you can specify a custom label. See "Roof Plane Labels" on page 364.

For information about the settings on this tab, see "Label Tab" on page 885.

Gable/Roof Lines



The **Gable/Roof Line** tool can be used to automatically generate a gable above the bearing wall of a hip roof plane. It is best used in situations where roof directives in walls are not possible. For example:

- If a Wall Break would be required in the same location as a door or window;
- Where a wall is not present, such as across the front of an alcove;
- Over a Bay, Box, or Bow Window.

See "Roof Directives in Walls" on page 204.



In addition, the **Gable Over Door/Window** edit button allows you to add a small Gable/Roof Line over one or more selected doors or windows the next time automatic roof planes are built.

Gable/Roof Lines display in floor plan view when the "Roofs, Gable Lines" layer is set to display and can be selected and edited much like regular CAD lines. See "Editing Line Based Objects" on page 127.

Creating a Gable

To create a gable using a Gable/Roof Line

1. Select **Build> Roof> Gable/Roof**

Line , then click and drag to draw a line outside of the exterior wall that you want to create a gable over.

2. Position the Gable/Roof Line within 10 feet (2260 mm) of the wall's Main Layer but not touching it. See "The Main Layer" on page 209.
 - Make sure that the Gable/Roof Line is exactly parallel to the exterior wall.

3. Resize the Gable/Roof Line so that it is the length of the desired gable.
 - The length of the Gable/Roof Line determines the gable width at the wall Main Layer, not at the overhang.
 - At the larger roof eave, a gable roof is wider than the gable line by twice the overhang distance.

4. Select **Build> Roof> Build Roof**  and regenerate the roof. See "Build Roof Dialog" on page 355.

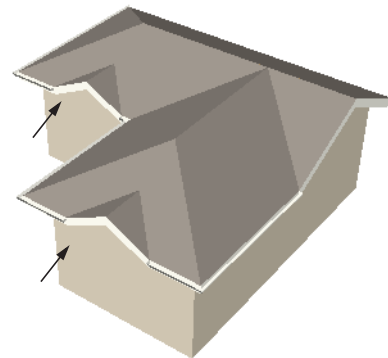
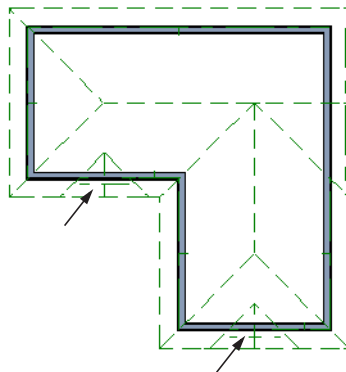

Gables produced using Gable Roof Lines

To use the Gable Over Door/Window tool



1. Select one or more doors or windows.
2. Click the **Gable Over Door/**

Window  edit button.

- **Gable Over Door/Window**  is not available for openings placed in Full Gable Walls or for Bay, Box or Bow

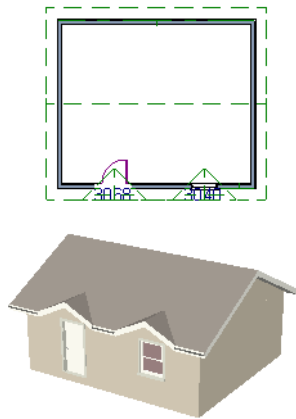
3. The next time automatic roof planes are built, gables will be created over each of these doors and windows.
 - Each gable will extend 12" (300 mm) on either side of its door or window.
 - If two of these openings are within 30" (750 mm) of each other on the same wall, a single gable will be created.
- Windows. See "Bay, Box, Bow Windows & Roofs" on page 292.



- If you move or resize the door or window(s), the associated Gable/Roof Line will not update until the roof is built again.
4. To remove a Gable Over Door/Window, select the door(s) or window(s) and click the **Delete Gable Over Opening**  edit button, or select the gable line and click the **Delete**  edit button. The next time the roof is built, the gable will be removed.

Covering an Alcove

A **Gable/Roof Line**  can also be used to maintain a roof plane baseline where there is no wall below. For example, you can use it to extend a roof plane across an alcove, rather than wrap into it.

In order for a **Gable/Roof Line**  to direct the roof to extend over an alcove or other area where no wall is present, it must be aligned with the exterior walls' Main Layer.

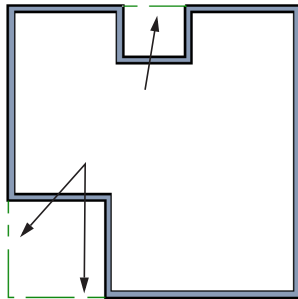

Gable/Roof Lines drawn to extend roof planes

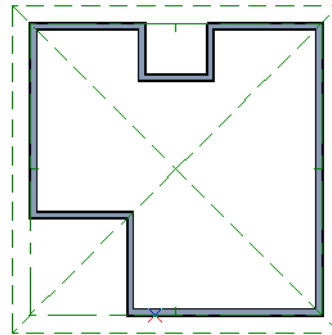

Result, after automatic roof generation

Covering a Bay

A **Gable/Roof Line**  drawn across a bay causes a gable to be build above the bay when roofs are automatically generated.

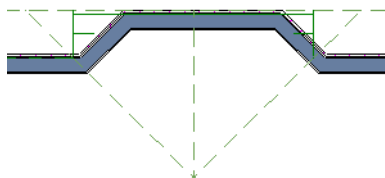

Gable/roof line used to create a gable over a bay

In order for the gable to be built, at least one end of the Gable/Roof Line must extend past the side walls of the bay.

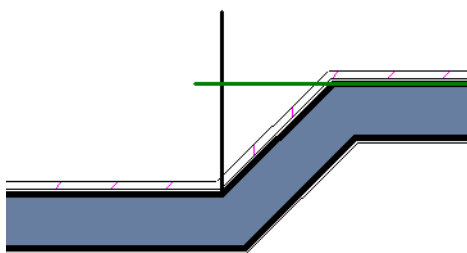

Gable/roof line extends past end of side wall

If the Gable/Roof Line is drawn along the outer edge of the bay's outer wall's Main Layer, the resulting gable will extend only to the eave of the larger roof. Draw the Gable/Roof Line beyond the bay's outer wall to extend out past the larger roof's eave.

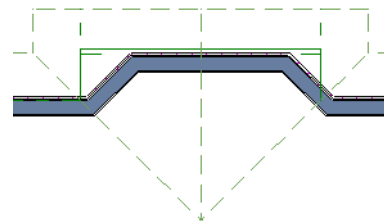

Gable/roof line drawn beyond outer wall of bay results in gable extending to cover bay

Skylights

 A skylight can be created by selecting **Build> Roof> Skylight** and drawing a rectangular polyline within a single roof plane. You can also simply click once within a roof plane to place a 2' x 2' skylight.

The **Skylight**  tool places a flat panel skylight into a roof hole, produces a hole in the ceiling platform below, and automatically generates the skylight shaft between these two holes.

To place a skylight in a vaulted ceiling, uncheck **Ceiling Over This Room** in the **Room Specification** dialog, draw the ceiling planes to produce the vault and edit them as needed, and then draw the skylight. See "Structure Tab" on page 245.

Note: If a sloped ceiling plane is present under the skylight, a hole in this ceiling plane is automatically produced. This hole is visible, and may be located directly under the roof hole. It can be moved and edited separately.

Editing Skylights

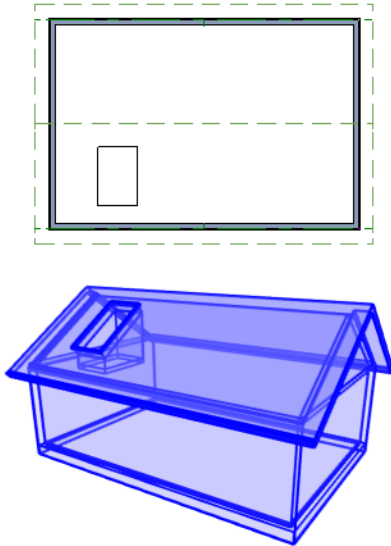

Skylights can be selected individually or in groups. Once selected, skylights can be edited using the edit handles, edit toolbar buttons, or the **Roof Hole/Skylight Specification** dialog. See “Roof Hole/Skylight Specification Dialog” on page 386.

Skylights must always be contained by a single roof plane. If the roof plane is deleted, any skylights or holes it contains are also deleted. Aside from this restriction, skylights can be edited much like standard closed polylines. See “Editing Closed-Polyline Based Objects” on page 138.

If you clear the **Skylight** check box in the **Roof Hole/Skylight Specification** dialog, the curb and glass for the skylight is removed but the opening remains.

Roof Hole/Skylight Specification Dialog



Select a skylight and click the **Open Object** edit button to open the **Roof**

Hole/Skylight Specification dialog. See “Skylights” on page 385.

General Tab

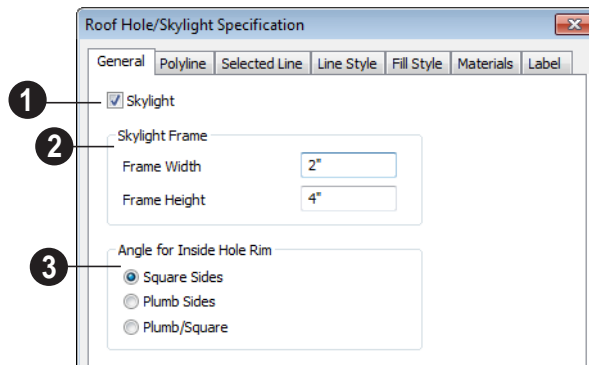

- 1 Check **Skylight** to specify this polyline as a skylight. If unchecked, the curb and glass for the skylight are removed but the opening remains.
- 2 **Skylight Frame Width and Height** - Define the width and height of the frame or curb of the skylight.
- 3 **Angle for Inside Hole Rim** - Defines the shape of the skylight well where it passes through the roof plane.
 - **Square Sides** - The framing for the skylight is cut square to the pitch of the roof.
 - **Plumb Sides** - The framing for the skylight is plumb-cut.
 - **Plumb/Square** - The bottom edge is plumb-cut, the top edge square-cut.

Polyline Tab

The Polyline tab indicates the roof hole/skylight's **Perimeter**, its **Framing Area**, and its **Projected Area**. See "Polyline Tab" on page 374.

Selected Line Tab

This tab is similar to the Line tab of the **Line Specification** dialog. See "Line Tab" on page 780.

Line Style Tab

For information about the settings on this tab, see "Line Style Tab" on page 781.

Fill Style Tab

The settings on the Fill Style tab control the appearance of the selected roof hole or skylight in floor plan view. For information about these settings, see "Fill Style Tab" on page 792.

Materials Tab

For information about the Materials tab, see "Materials Tab" on page 635.

Label Tab

Roof hole and skylight labels display when the "Roofs, Labels" layer is turned on and use the Text Style assigned to that layer. The Automatic Label for these objects is blank, but you can specify a custom label. See "Roof Plane Labels" on page 364.

For information about the settings on this tab, see "Label Tab" on page 885.

Dormers and Crickets



Dormers can be drawn manually or placed automatically using the **Auto Dormer** tools.

Automatic Dormers can be placed only under certain conditions:

- Automatic Dormers can only be placed entirely within a single roof plane. They

cannot extend past the eaves or ridge of this roof plane.

- Automatic Dormer side walls cannot be positioned above other walls in the plan.

If you click within a roof plane to place an automatic dormer, but click too close to an eave or the ridge, a dormer will not be

created; however, its outline will. Move this outline box to a location that meets the dormer's requirements and it will be created.

Automatic dormers reside by default on their own layer, "Auto Dormers". Their display cannot be turned off; however, you can lock this layer to prevent unintended editing. See "Layer Display Options Dialog" on page 104.

Auto Floating Dormer



Select **Build > Roof > Auto Floating Dormer** and click the roof plane where you would like to place the center of the dormer's front wall.

The bottom edges of all floating dormer walls are cut off by the underlying roof plane. To produce such a dormer manually, check **Roof Cuts Wall at Bottom** for the dormer walls on the Roof tab of the **Wall Specification** dialog.

Usually, no room is defined by the walls of this type of dormer.

The images below show both the outside and inside of a typical floating dormer.

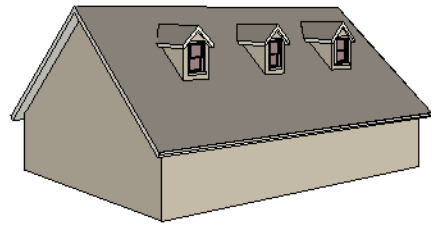

A floating dormer can be placed in floor plan view on the same floor that its underlying roof plane displays on, or it can be placed on the floor above. Normally, it does not matter what floor the dormer is on, but in some cases, it may need to be on the floor above so that the dormer walls do not interfere with walls or railings in the room below.

Regardless of which floor it is placed on, a dormer must always fit within a single roof plane. When placing a dormer on the floor above, you may find it helpful to turn on the **Reference Display** . See "Reference Display" on page 327.

You may also find it helpful to display the underlying roof plane on the floor above using the **Roof Plane Specification** dialog. See "Roof Plane Specification Dialog" on page 371.

If the dormer is placed on the same floor as the underlying roof plane and the room below, and the room has a flat ceiling, then

defining a room, which is automatically Open Below, causes a hole to be produced in the ceiling under the dormer.

Auto Dormer



Select **Build> Roof> Auto Dormer** and click on a roof plane where you want the center of the dormer's front wall to be.

The walls of an auto dormer go to the floor and meet a knee wall on either side on the back of the dormer. This knee wall must run parallel to the underlying roof plane's Baseline.

- If you are creating a (non-floating) auto dormer, a knee wall must already exist. The dormer side walls run back to the knee wall and the knee wall is broken where the dormer walls meet it.
- The knee wall does not have to be designated as such in the **Wall Specification** dialog unless you are generating an automatic roof. See “Knee Walls” on page 206.
- A non-floating dormer must always be created on the same floor as the knee walls.

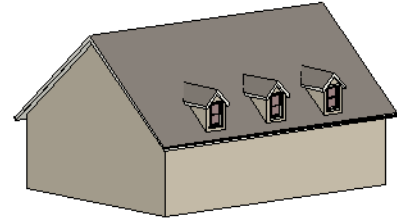
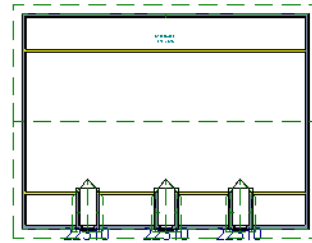

The initial width, height, roof style and other settings of Auto Dormers are set in the **Dormer Defaults** dialog. See “Dormer Defaults” on page 351.

Manually Drawn Dormers

Once you are familiar with Home Designer Pro's roof tools, drawing dormers manually can be quite simple. There are several different ways to draw dormers; some methods work better in certain applications.

A variety of resources with information about drawing dormers manually is available at www.HomeDesignerSoftware.com.

See, too, “Manually Drawn Dormers” on page 87 of the User's Guide.

There are a few things to keep in mind.

- Walls extend upward until they meet an overlying roof plane.
- A wall can also be cut by underlying roof planes if **Roof Cuts Wall at Bottom** is checked in the **Wall Specification** dialog. For this to work properly, the edge of the roof plane must extend completely through the width of the wall. See “Clere-story and Dormer Walls” on page 205.

- Polylines can be converted into a **Hole in Roof/Ceiling** that allows walls to extend above or below the roof line. See “Convert Polyline” on page 165.

Manually Drawn Crickets

The automatic roof generator will not produce crickets in a roof plan; however, you can manually draw a cricket using the **Roof**

Plane  tool. See “Crickets and Dormer Vents” on page 95 of the User’s Guide.

Editing Auto Dormers

Auto Dormers are a collection of objects that behave as one. When a dormer is selected, it can be edited using its edit handles, edit tools, and specification dialog. See “Dormer Specification Dialog” on page 391.

If you click the **Explode Dormer**  edit button, the dormer’s individual components can be edited.

Using the Mouse

When selected, an auto dormer displays three edit handles. The Move handle displays over the front wall and allows you to relocate the dormer. Two resize handles display on the side walls and allow you to change the width of the dormer.

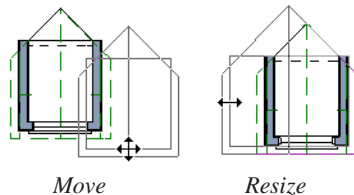

There are some things to keep in mind when editing auto dormers and auto floating dormers using the mouse.

- Dormers move at 90° angles unless the Ctrl key is pressed before moving them.
- The dormer must be contained within one underlying roof plane.
- Auto dormers cannot be moved beyond the required knee wall.

Editing the Window

Dormer windows can be selected, edited, deleted and replaced just like other windows. See “Editing Windows” on page 289. You can place several windows in the front wall.

Unless the dormer’s window has been edited or changed in the **Window Specification** dialog, when the dormer width is changed, its width changes automatically to fill the front dormer wall. If the window has been edited, its width stays fixed. If a change to the dormer makes its front wall too short to hold the window, the window reverts to auto width.

Exploding Dormers



Click the **Explode Auto Dormer** edit button to explode the auto dormer into its component parts. The dormer walls, roof planes, window, and hole in the roof/ceiling can be edited individually.

The program treats roof planes over an exploded auto dormer as though they were manually drawn, allowing you to protect them from being rebuilt in the **Build Roof** dialog. See “Roof Tab” on page 356.

Dormer Specification Dialog



Select a dormer or dormers and click the **Open Object** edit button to open the **Dormer Specification** dialog.

The settings in the **Dormer Defaults** dialog are much like those in the **Dormer Specification** dialog, but apply to all dormers as they are created rather than to a selected dormer.

General Tab

The screenshot shows the **Dormer Specification** dialog box with the **General** tab selected. The dialog is divided into several sections:

- Dormer Roof**: Includes **Roof Type** (Gable), **Pitch (in 12)** (12"), **Pitch in Degrees** (checkbox), **Second Pitch** (4"), **In from Eave** (6"), **Boxed Eaves** (checkbox), **Gutter** (checkbox), **Plumb Cut** (radio button), and **Square Cut** (radio button).
- Walls**: Includes **Wall Type** (Siding-6), **Height** (60"), **Set to Existing Ceiling** (checkbox), and **Width** (60").
- Roof Return**: Includes **Form Room Inside Dormer** (checkbox), **Roof Return** (checkbox), **Length** (12"), **Extend** (0"), and radio buttons for **Gable**, **Hip**, **Full**, **Sloping**, and **Flat**.
- Eave Overhang**: Includes **Eave Overhang** (6"), **Gable Overhang** (6"), **Fascia Depth** (5 1/2"), **Eave Fascia Depth** (5 1/2"), **Rafter Depth** (5 1/2"), and **Vertical Rafter Depth** (7 3/4").
- Set Inside Window Trim Width**: Includes **Set Inside Window Trim Width** (checkbox) and **Inside Window Trim** (2").

Numbered callouts (1-10) point to the following elements:

- Roof Type dropdown
- Pitch (in 12) text box
- Boxed Eaves checkbox
- Eave Overhang text box
- Set Inside Window Trim Width checkbox
- Wall Type dropdown
- Height text box
- Width text box
- Form Room Inside Dormer checkbox
- Roof Return checkbox

- 1 Specify characteristics of the selected dormer's **Dormer Roof**.
- Choose a **Roof Type** from the drop-down list. You can choose from Hip, Gable, Shed, Gambrel, Mansard, Barrel, Curved Eave, Hip Curved Eave or Eyebrow.



Dormer Roof Types

- Specify the **Pitch** of the dormer roof planes. Initially, the default dormer pitch matches the roof pitch for all dormer roof types except Shed, which has a default 3 in 12 pitch. For Gambrel and Mansard types, this applies to the lowest, or eave, roof planes.
 - Check **Pitch in Degrees** to display the pitch in degrees rather than in rise and run.
- 2 The **Second Pitch** specifies the upper roof of a Gambrel, Mansard, curved eave, and hip curved eave. Specify the **In from Eave** distance measured from the lower roof plane eave to where the upper roof plane starts.
 - 3 Plumb or Square cut eaves can be specified for dormer roof planes, as well as **Gutters and Boxed Eaves**.
 - 4 **Eave and Gable Overhang, Fascia Depth** for gable fascia, **Eave Fascia Depth** and **Rafter Depth** can also be set.

- 5 Only available in the **Dormer Defaults** dialog, if **Set Inside Window Trim Width** is checked, the inside casing width for dormer windows defaults to the **Inside Window Trim** value entered below. Dormer windows can appear too narrow on the outside due to the space required for the inside casing to clear the inside surfaces of the side walls. This value sets the width for the inside casing of the dormer window.

- 6 Specify the **Wall Type** of the dormer walls here.
- 7 Specify the **Height** of the dormer, as measured from where the top of the underlying roof plane meets the dormer front wall exterior to the top plate of the dormer roof's bearing walls.

This top height is called the dormer ceiling height, even if the ceiling in the dormer is not flat. The top dormer window casing is usually close to this height.

- Check **Set to Existing Ceiling** to assign the ceiling height of the room behind the dormer to the dormer.
 - **Height to Reach Existing** shows the difference between the dormer height where the inside of the wall meets the underside of the roof and the ceiling of the room behind it.
- 8 **Width** is measured between the outside surfaces of the dormer side walls.
 - 9 **Form Room Inside Dormer** is used only for floating dormers and creates a flat ceiling in the dormer. If you check this option, you should define the dormer on the floor above the room it is positioned over. If this room has a flat ceiling, checking this option makes a hole in the ceiling under the

dormer. This option should normally be left unchecked.

10 **Roof Returns** can be specified only for gable dormers. See “Roof Returns” on page 393.

Line Style Tab

For information about the settings on this tab, see “Line Style Tab” on page 781.

Roof Returns and Other Details

Home Designer Pro offers a selection of tools to add architectural details to your roof design.

Roof Returns

A roof return is a small decorative roof plane that connects to the low side of a gable roof overhang and extends below the upper triangular portion of the gable wall. Three styles of roof returns that can be produced automatically.

The first two styles are called **Gable** and **Hip** returns since the return ends in a gable or hip.

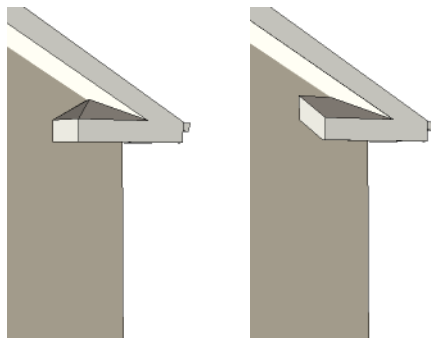

Hip Return

Gable Return

The third is called a **Full** return because it extends under the entire gable to connect both sides and is sometimes referred to as a water table. In order for a Full return to be

created, the roof planes on each side must have the same Fascia Top Height.

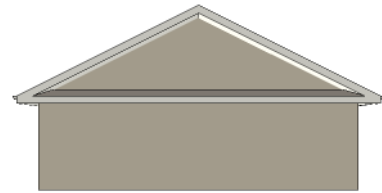

Full Return

It is not difficult to manually draw roof returns using small roof planes, but it is quicker to produce them automatically.

Roof returns are generated automatically on a wall by wall basis using settings found in the **Wall Specification** dialog. See “Roof Tab” on page 218.

The structure of automatically generated roof returns is the same as that of the subfascia and eaves of the roof plane above. See “Roof Tab” on page 451.

These roof return settings are also found in the **Dormer Specification** dialog for gable roof dormers and function similarly. See “General Tab” on page 391.

Fascia

Fascia can be added to both automatic and manually drawn roof planes. They can be

generated when the roof planes are drawn when specified in the **Build Roof** dialog, and can also be added to or removed from individual roof planes in the **Roof Plane Specification** dialog.

- Fascia and eave fascia can be specified in the **Build Framing** and **Build Roof** dialogs. See “Roof Tab” on page 451.
- Fascia is generated whenever **Build Fascia and Roof Trim** is checked. See “Roof Tab” on page 356.
- The material used for fascia can be specified. See “Materials Tab” on page 362.

Fascia display in 3D views and are included in the materials list. You can also display them in floor plan view, if you wish. See “Layer Display Options Dialog” on page 104.

Fascia

The material specified for fascia in the **Build Roof** dialog displays as part of the roof plane rather than as a separate object.

In addition, fascia boards are generated when roof framing is generated and are placed on

the “Framing, Roof” layer. The fascia material is not applied to these framing members, however.

The width and depth of fascia and eave fascia can be specified in the **Build Framing** dialog. See “Roof Tab” on page 451.

Gutters

Gutters are added to non-sloping eaves on both automatic and manually drawn roof planes when **Gutters** is checked in the **Build Roof** dialog. They can also be added to or removed from individual roof planes in the **Roof Plane Specification** dialog. See “Options Tab” on page 360.

Automatically generated gutters follow the eaves of the roof but are not created on sloped gable eaves.

Gutters are placed on the “Roofs, Gutters” layer. By default, this layer is turned on in 3D views but not in plan view, is included in the materials list, and is locked. See “Layer Display Options Dialog” on page 104.

Roof Pitches in Degrees

$$\angle^\circ = \frac{\text{rise}}{\text{run}}$$

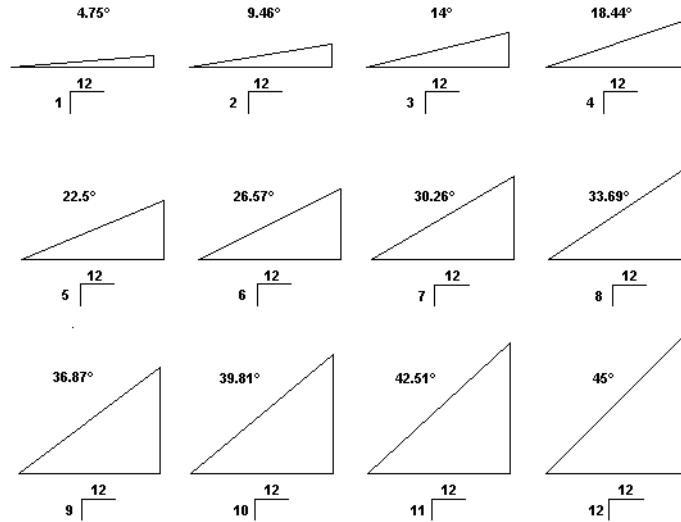

Stairs, Ramps & Landings

Staircases can be composed of one or more straight or curved stair sections, ramps, and landings. Stairs and ramps can be drawn, selected and edited in 2D and 3D views.

Stair sections can be edited individually or as a group. Starter treads can be defined, stair sections can be flared, treads can be wrapped, and curved sections can be turned into winders.

Landings can be created automatically or manually and their shape customized. You can edit an existing landing, or create a landing from a closed CAD polyline. Landing heights can be defined or you can let them automatically adjust as needed.

Stairwells can be created automatically or manually and can be seen in 3D views.

Chapter Contents

- Stair and Ramp Defaults
- The Stair Tools
- Anatomy of a Staircase
- Drawing Stairs and Ramps
- Displaying Stairs, Ramps, and Landings
- Editing Stairs and Ramps
- Merging Stair and Ramp Sections
- Landings
- Maintaining Tread Depth
- Flared Stairs and Curved Treads
- Starter Treads
- Winders
- Wrapped Stairs
- Other Special Railings & Stairs
- Creating a Stairwell
- Rooms Below Staircases
- Staircase Specification Dialog
- Ramp Specification Dialog
- Stair Landing Specification Dialog



Local building and fire authorities must be consulted for specific stair construction codes and access requirements.

Stair and Ramp Defaults

The purpose of interior stairs is to provide passage from one floor platform to another, so the attributes that influence floor heights - including ceiling heights, floor platform thicknesses, and floor finish materials - also influence the structure of stairs. When considering a staircase's structure, bear in mind that riser height is directly dependent on the distance from one floor platform to another.

When **Automatic Heights** are used, stairs are built so that they rest on the top of the

floor structure of the floor where they are drawn, and build up to the top of the floor structure on the floor above. Risers are measured to the floor finish surfaces on both floors. See "Floor and Ceiling Platform Definitions" on page 322.

Ramps are built in a similar manner: interior ramps bear on the floor structure, and when **Automatic Heights** are used, the top surface of both interior and exterior ramps locates floor finish surfaces.

The Stair Tools



Select **Build> Stairs** to access the Stair Tools.

Straight Stairs



To draw a straight staircase select **Build> Stairs> Straight Stairs**, then click and drag in floor plan or a 3D view. You can also click once to place a staircase that extends from the current floor up to the next floor. See "Drawing Stairs and Ramps" on page 400.

Click Stairs



Select **Build> Stairs> Click Stairs** to create stairs between levels on the same floor with a single click of the mouse. Click the low side, within a few feet of where the floor changes height.

- If you click on the low side of a floor platform defined by a railing, a doorway

will be created in the railing, adjacent to the stairs.

- If you click on the low side of a floor platform defined by a wall, stairs will be created but a doorway will not.
- If you click at a location that is not near the edge of a floor platform, a full height staircase will be created.

Curved Stairs



Select **Build> Stairs> Curve to Left** or **Curve to Right** and click once in floor plan view to place a curved staircase. See "Curved Stairs and Ramps" on page 401.

Landing



Select **Build> Stairs> Landing** to draw a landing, which is a platform connecting two or more stair sections. See "Landings" on page 406.

There are two ways to create a landing using this tool:

- Click once to place a landing measuring 39" (975 mm) on each side.
- Click and drag from end to end to draw a rectangular landing sized as needed. See "Polylines" on page 790.

You can also create a landing by converting a CAD polyline. See "Convert Polyline Dialog" on page 165.

Ramp



Select **Build> Stairs> Ramp** to draw a sloped ramp. By default, ramps are drawn at a 1:12 slope to a maximum height of 30" (760 mm). See "Drawing Stairs and Ramps" on page 400.

Anatomy of a Staircase

Stairs are often described in terms of **rise** and **run**. Rise is typically between 6" and 8", and the run between 10" and 12". In metric plans, rise is 177 to 190 mm, and the run is about 250 mm.

Staircase Terminology

Balusters - The vertical members that run between the handrail and the treads or bottom rail.

Bracket - Decorative L-shaped supports on the exposed side of stairs below each tread.

Landing - A platform connecting two or more stair sections.

Newels - The end post of a stair railing located at landings and the beginnings and endings of new stair sections.

Rise - The height of a riser, measured from tread surface to tread surface, Also referred to as Unit Rise.

Rise Angle - The angle of the staircase or stair section, defined by a line drawn through the back surfaces of its treads.

Riser - The vertical stair member located between the treads. Risers may be solid or open. When open, the front surfaces of the stringers are considered the risers.

Run - The depth of a tread, measured from riser surface to riser surface. Run does not include the Tread Overhang. Also referred to as Unit Run.

Runner - The carpet that runs down the center of the staircase.

Shoe - The bottom railing, placed on the landing floor, that anchors the balusters at landings.

Stringer - The inclined support member of a staircase that supports the treads and risers.

Tread - The horizontal member of a stair that the foot is placed on.

Tread Overhang - The portion of a tread extending past the front surface of the riser and over the tread below. Also referred to as Nosing or Nosing Extension, it is not included in the Run or Tread Depth measurements.

Thread Thickness - The vertical depth of the tread material.

Winder - A wedge-shaped stair tread used where curved or angled stairways change direction.

Stair Structure and the Model

By default, stairs locate the height of the floor platform that they are drawn on, and seek the next level, which may be the floor platform of the floor above or a landing. The stringers locate the subfloor of the floor platforms and maintain consistent riser height. If the stairs are long enough to reach the next level at a reasonable rise angle, their tread depth and number of treads are automatically calculated to create a staircase with consistent tread and riser dimensions along its entire length.

You can modify this behavior or turn off it off altogether in the **Staircase Specification** dialog and specify your own rise and run values. Bear in mind, though, that if you turn it off, you will need to specify the correct **Top** and **Bottom Heights** to make sure that the stairs actually meet both floor platforms correctly. See “General Tab” on page 422.

Stair Sections and Subsections

In Home Designer Pro, staircases can be composed of multiple sections and subsections. See “Merging Stair and Ramp Sections” on page 404.

- Stair sections are separated by landings.
- Subsections are considered part of the same section because they are connected to one another directly rather than separated by a landing.

Drawing Stairs and Ramps

Stairs and ramps can be drawn in floor plan and 3D views but not in cross section/elevation views. In 3D views, these objects can only be drawn in the presence of a floor platform or terrain perimeter. See “Working in 3D” on page 687.

There are a few things to keep in mind when drawing stairs.

- Before stairs are created, make sure that the heights for both the lower and upper floors are correctly defined.
- Stairs are drawn going **UP**, so they should be drawn from the lower of the two floors they connect.
- By default, stairs adjust their riser and tread dimensions to connect two floor heights if possible. The rise and run are calculated so that the steps are consistent in size.
- If you have the **Reference Display**  turned on, stairs snap to the reference display. See “Reference Display” on page 327.
- If a stairwell room has been defined on the floor above, the top of the stairs can be dragged until it stops at the railing or wall defining the stairwell.
- When drawing stairs or a ramp up from the terrain, it is a good idea to make sure

the terrain is up to date. See “Building the Terrain” on page 552.

Straight Stairs and Ramps

Straight Stairs  can be created in three different ways:

- Click and drag in a straight line to draw stairs that are the length that you drag.
- Click once to place stairs that go from the current floor up to the height of the next floor level.
- Click once using the **Click Stairs**  tool to create stairs between rooms on the same floor with different floor heights or between exterior rooms and the terrain.

Similarly, **Ramps**  can be created by either clicking and dragging or by clicking. A ramp created with a single click will be 30” (760 mm) high, have a slope of 1:12, and be 360” (9120 mm) long.

An individual stair or ramp section must be between 6” (150 mm) and 100’ (30,000 mm) in length. If a greater length is needed, connect two sections using a landing.



Curved Stairs and Ramps

 **Curved Stairs** can be created in floor plan view by selecting **Build> Stairs> Curve to Left** or **Curve to Right**. Click to place a 90° curved stair section that can then be edited. You can continue clicking to place additional curved staircases until another tool is selected.

In addition, you can change a straight stair section into curved stairs, or vice versa:

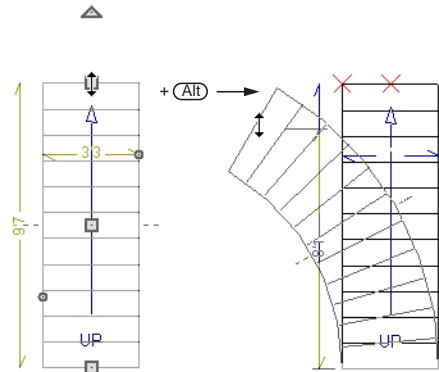
- Select the stairs and click the **Change Line/Arc**  edit button. See “Change Line/Arc” on page 159.
- Select the stairs, hold down the Alt key (or right-click), and drag an end edit handle. See “Alternate” on page 121.



Curved Ramps  can only be created by first creating a straight ramp and then clicking the **Change Line/Arc**  edit button.

Drawing Stairs and Ramps Downward

Stairs and ramps can be drawn from the current floor level downward; however, drawing stairs or ramps between floors in this manner is not recommended. Drawing downward should only be used to create a staircase or ramp between a porch or deck and the terrain when you require the direction arrow to say “DN” instead of “UP”.

To draw stairs going downward

1. Select **Build> Stairs> Straight Stairs** .
2. Hold down the Alt key or the right mouse button.
3. Click and drag to create straight stairs.

When drawing stairs or ramps from a floor platform to the terrain, or vice versa, they will locate the height of the terrain as long as it is lower than the floor height. You can also create a landing or “room” outside the structure and use it to establish the bottom height of the stairs or ramp. Then, draw in an upward direction from the lower platform to the upper platform.

Displaying Stairs, Ramps, and Landings



The display of stairs, ramps, and landings in all views is controlled in the **Layer Display Options** dialog. Stairs, ramps, and landings are placed on the **Stairs & Ramps** layer. See “Displaying Objects” on page 102.

In Floor Plan View

In floor plan view, stairs, ramps and landings display on the floor they were drawn on and are only visible from the floor above if there is a stairwell.

Stairs and ramps have an arrow indicating the direction they run. Interior stairs and ramps have an **UP** arrow on the floor they were created on and a **DN** arrow when viewed from the floor above. See “Drawing Stairs and Ramps” on page 400.

The style and size of a direction arrow can be specified in the **Staircase** or **Ramp Specification** dialog. The color and display are controlled by the “Stairs & Ramps, Up/Down Arrows” layer. See “Arrow Tab” on page 783.

When a staircase is selected in floor plan view, the numbers associated with each of its sections and subsections display. Stair

sections are assigned a single-digit number. Subsection numbers have two parts: a section number and subsection number, separated by a hyphen.

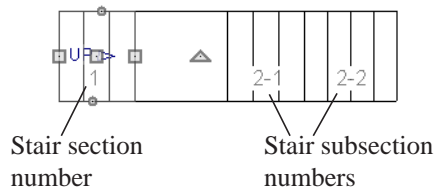

To see the center of a stair section curve in floor plan view, click **Show Arc Centers and Ends** . See “Show Arc Centers” on page 134.

In 3D Views

Although stairs span between two floors, they can only belong to one floor. As a result, only multi-floor views show the upper floor with the platform opening and the lower floor with the staircase simultaneously. In **Floor Cameras** and Doll House Views, stairwells may appear as an empty spaces. See “3D View Tools” on page 672.



Editing Stairs and Ramps

Staircases and ramps can be selected and edited in floor plan view and 3D views. See “Selecting Objects” on page 124.

Using the Mouse

When a staircase or ramp is selected, its edit handles display. These edit handles can be used to customize the object in many ways. See “Editing Objects” on page 119.

- Straight stair sections and ramps are edited like lines. They have additional edit handles for resizing the width of the section. See “Editing Line Based Objects” on page 127.
- Curved stair sections and ramps are edited like arcs and also include edit handles for resizing the stair’s width. See “Editing Arc Based Objects” on page 130.
- Ramps can be resized to a maximum top height of 30” (760 mm). If you extend a ramp’s length to greater than 360” (9120 mm), it’s slope will decrease. For a taller ramp and control over the slope, uncheck **Automatic Heights** in the **Ramp Specification** dialog and specify the values you need. See “General Tab” on page 431.
- When stair sections are merged, the edit handles display differently depending on what subsection is currently selected. See “Merging Stair and Ramp Sections” on page 404.
- When moving merged stair or ramp sections, all merged sections move as one.

- Additional edit handles display on the first two treads of a staircase if the **Starter Tread**  edit button is clicked. See “Starter Treads” on page 413.
- Several additional edit handles display on a staircase if the **Flare/Curve Stairs**  edit button has been clicked. See “Flared Stairs and Curved Treads” on page 410.

In the Specification Dialog

 Stairs and ramps can be customized and their structure precisely defined in the **Staircase and Ramp Specification** dialogs. See “Staircase Specification Dialog” on page 422 and “Ramp Specification Dialog” on page 430.

Using the Edit Tools

A selected staircase or ramp can be edited in a variety of ways using the buttons on the edit toolbar. See “The Edit Toolbar” on page 29.

Adjusting the Radius of Curved Stairs

The easiest way to match the radius of a stair section to the radius of a curved wall is to draw a staircase near one side of the curved wall using the **Straight Stairs**  tool. The stairs snap to the wall, and the radius of the new staircase is defined. See “Curved Stairs and Ramps” on page 401.

Existing curved stairs can be aligned with an existing curved wall by aligning their centers, much the same way that curved

stairs on different floors can be aligned. See “Aligning Objects” on page 154.

If there is no curved wall, the radius of a stair section can be aligned to a CAD arc or circle.

To align curved stairs to an object

1. Align the centers of the CAD object and the staircase.

2. Select the curved stairs and move the side nearest to the arc or circle edge using the **Resize** edit handle.

Finally, restore the stair width by dragging from the other side handle or using the **Stair Specification** dialog.

Merging Stair and Ramp Sections

Any combination of straight and curved stair sections or straight and curved ramps using **Automatic Heights** can be merged. The resulting staircase or ramp section is made up of subsections and, if there are no landings, functions as a single unit.

Stair and ramp subsections must be drawn in the same direction if they are to be merged:

- The top edge of a stair section or ramp cannot merge with the bottom edge of another section or ramp.
- Combinations of stairs drawn in the **UP** and **DOWN** directions cannot be merged.

Stair subsections merge at the center points of their upper and lower edges.

Stair sections and ramps cannot be merged directly. If a combination of stairs and a ramp is required, connect them with a landing. See “Landings” on page 406.

To merge stair or ramp sections

1. Confirm that the stairs or ramps that you wish to merge are using **Automatic Heights**. See “General Tab” on page 422.
2. Position the sections so they are in the desired relationship to each other.
 - In order to merge stair sections correctly, they must be parallel to one another.
 - To create merged subsections that change direction, make one of the merged sections curved and then specify Winders. See “Winders” on page 414.
3. Select either stair or ramp section so that its edit handles display.
4. Click the Extend handle on the end to be merged and drag it to the point where the two stairs or ramps are to meet.

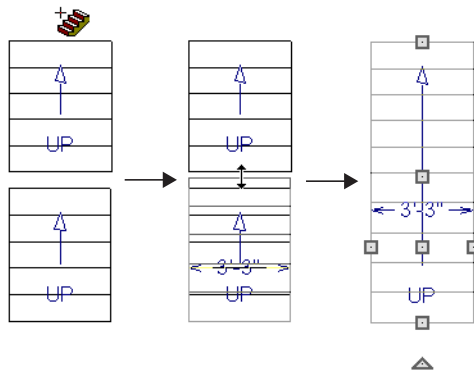

Merging parallel stair sections

A staircase consisting of merged subsections resembles a single stair section in floor plan view. The **UP** (or **DN**) arrows join, becoming a single direction arrow.

When a subsection is selected, the entire staircase is selected. Additional edit handles, indicating the presence of multiple subsections and allowing you to reposition the line along which they join. See “Using the Mouse” on page 403.

Lock Tread Depth

If a staircase with **Lock Tread Depth** selected in the **Staircase Specification** dialog is resized, its length increases or decreases one full tread at a time. See “General Tab” on page 422.

When **Lock Tread Depth** is checked, it can be difficult to merge the section with another section or landing. If this is a problem, you can temporarily uncheck **Lock Tread Depth**. After the stairs are merged, the tread depth can be locked again.

Curved Subsections

Stair subsections attached at both ends by other sections do not have a free end that can be dragged into a curve. In this situation, change the middle sub-section to a curve using the **Change Line/Arc**  edit button. See “Change Line/Arc” on page 159.

To curve an enclosed stair subsection

1. Draw three straight stair sections and connect them end to end.
2. Select the middle subsection.

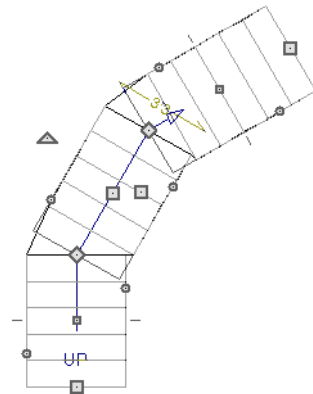

Select the middle stair subsection

3. Click the **Change Line/Arc**  edit button. The center section turns into a curved stair section.

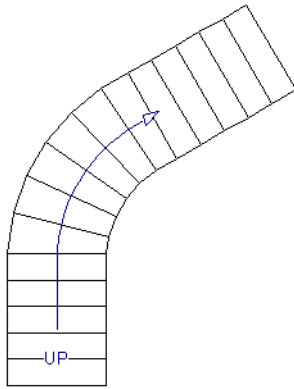



After using Change Line/Arc

4. Use the triangular Change Curve edit handle to adjust the curvature of the middle section as needed.

Stairs joined in this manner can easily be turned into winders. See “Winders” on page 414.

Landings

Stair landings are platforms between stair sections and/or ramps, and can be created in either of three ways:

- Using the **Landing**  tool.
- By clicking between two stair sections using the **Straight Stairs**  tool.
- By converting a closed CAD polyline into a landing. See “Convert Polyline” on page 165.

To create a landing between stair sections:

1. Draw two stair sections going UP. They can be at any angle.
2. Click between the two sections using the **Straight Stairs**  tool to create a landing. Notice that only one direction arrow displays after the sections are joined by a landing.

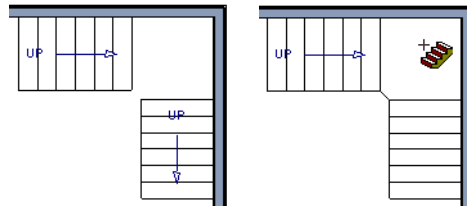

Creating a stair landing

Similarly, a landing can be created between two ramps by clicking between them with the

Ramp  tool active.

Multiple stair sections and/or ramps can be connected to one landing. For example, two or three stair sections might meet at a landing with a single stair section continuing to the next level.

To be linked by a landing, all sections must be drawn in the same **UP** direction and the top of one section should be near the bottom of the next.

Stair sections connected with a landing will move together as a single unit unless **Stair Sections Move Independently** is checked in the **Preferences** dialog. See “Architectural Panel” on page 73.

A landing formed between two stair sections having less than a 90° angle between them are created with a short edge not less than 6” (150 mm). This is because most building codes require the shortest tread to be at least 6” wide. This edge can be manually edited to less than 6” if needed.

Editing Landings

Landings can be selected in 2D and 3D views, both individually and in groups, and edited using the edit handles, the edit toolbar, and the **Landing Specification** dialog. See “Stair Landing Specification Dialog” on page 433.

Landings derive their initial materials and railing characteristics from the stairs and/or ramps attached to them. You can assign a unique material to a landing in its specification dialog or using the **Material Painter** ; however, the railing style is always defined by the attached stairs or ramps.

Custom Shaped Landings

Landings can be edited like other closed polyline-based objects. You can add or remove edges, convert an edge from straight to curved, or vice versa. A curved landing creates curved railings. See “Editing Closed-Polyline Based Objects” on page 138.

You can also create a stair landing out of closed polyline created with the CAD tools

using the **Convert Polyline**  edit button. See “Convert Polyline” on page 165.

You can edit the shape of a landing into a wide variety of shapes. So that the railings of stair sections connect properly to the landing railings, make sure that each stair section end is snapped to a landing edge with the same length as the stair’s width. If necessary, use

the **Break Line**  tool to create a break in a landing edge if it is longer than the connecting stairs are wide. See “Break Line” on page 158.

Landing Height

A landing’s height can be either user-defined or controlled by the program.

A landing with a height that has not been specified by the user is considered unlocked, and its height will adjust automatically as the stairs attached to it are modified so that the stairs maintain a consistent rise angle.

If you specify a landing’s height, that landing becomes locked and will maintain that height no matter how the stairs connected to it are adjusted.

Unlocked Landings

By default, new landings are unlocked, which means that their height is determined by the stair or ramp sections attached to it. An unlocked landing will automatically adjust its height as necessary to maintain the same riser height and rise angle for all attached sections.

In this example, two stair sections with eight treads each are connected by a landing.

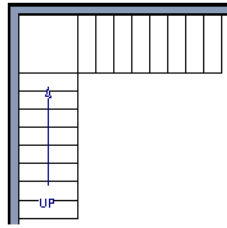

Because the sections have the same number of treads, the landing height is one half of the distance between the two connected floors.

Unlocked landings maintain consistent riser height

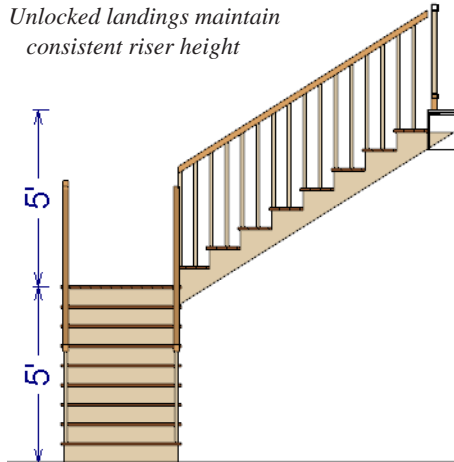

If a change is made to either stair section, the program will maintain the stairs' connection to the floors above and below, and will instead modify the height of the landing and the other stair section so that a consistent riser height is maintained.

As long as a stair or ramp system consists of a landing connecting only two stair sections, the program can easily set landing heights and produce consistent a rise angle. If more than two stair sections meet at a landing, the relationship between them becomes more complex. In this situation, you may want to

define the exact height of the landing instead of letting the program define it for you.

Locked Landings

A locked landing has a specifically defined height that does not adjust automatically when there are changes in the attached stairs. Instead, the stairs adjust to the landing.

For example, start with the same staircase used to illustrate unlocked landings, with one change: the landing height is now defined at 78 inches (1980 mm).

Locked landings produce independent stair sections

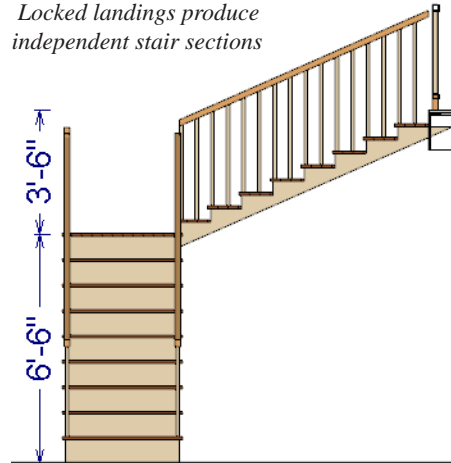

Since the landing height is now closer to the upper floor than to the lower floor, the upper stair section has a very shallow riser height and the lower section has a tall riser height.

Stair and ramp sections attached to a locked landing no longer relate to one another:

- Changes to one section do not affect the other.
- The **Staircase** and **Ramp Specification** dialogs show only the selected section

and those connected to it by unlocked landings, rather than the entire system.

- Locked landings do not move when attached stair or ramp sections are moved. Only unlocked landings and the sections attached to them will move.

Locked landing can be used to break up a complex network of stairs and landings into smaller pieces with known bottom and top heights.

To lock a landing

1. Select the landing and click the **Open Object**  edit button to open the **Stair Landing Specification** dialog.
2. On the General tab, uncheck **Auto Adjust Height When Connected to Stairs**.

3. Specify the desired **Top Height** and click OK.
4. The landing moves to the specified height and all stairs that connect to that landing are redefined.

To unlock a landing, open its specification dialog, check **Auto Adjust Height When Connected to Stairs**, and click OK. The Top Height will automatically adjust to any stair or ramp sections attached to it and will try to produce a staircase with a single riser height.

To move stair sections independently regardless of whether attached landings are locked or unlocked, select **Stair Sections Move Independently** in the **Preferences** dialog. See “Architectural Panel” on page 73.

Maintaining Tread Depth

Most building codes require staircases to maintain a consistent tread depth.

Walk Line

By default, Home Designer Pro measures a stair section’s length and tread depth along a Walk Line located 12" (30 cm) from the right edge of the stair section by default. On curved stairs, it is located 12" (30 cm) from the inside edge of the curve.

The distance of the Walk Line from the staircase edge can be specified in the **Staircase Specification** dialog. See “Style Tab” on page 425.

Alternatively, you can turn the Walk Line feature off and tread depth will be measured at the tread center.

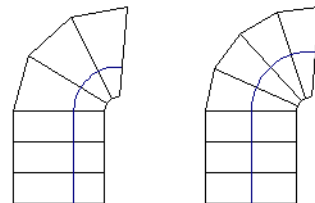

Walk Line at 12"

Center Line

When a curved stair section has **Automatic Treads** specified in the **Staircase Specification** dialog and the Walk Line is used, the number and/or width of treads in a section or subsection changes when the inner

edge is moved. For this reason, it is best to finalize stair section width as early as possible.

There are two ways to keep tread depth even throughout a stair section made of multiple subsections.

Lock Tread Depth

The first way to maintain tread depth is to **Lock Tread Depth** to a specified value in the **Staircase Specification** dialog. See “General Tab” on page 422.

Once locked, any changes to the length of the stair section are achieved by keeping the specified tread depth and changing the number of treads.

Ignore Subsection Boundaries

Curved stair sections typically have treads that are wider on one side than on the other. When they are connected to other stair sections, as with winders, it is possible to have treads that are too narrow at the Walk Line. See “Winders” on page 414.

Uniform tread depth in a stair section with subsections can be maintained by checking **Ignore Subsection Boundaries** in the **Staircase Specification** dialog. See “General Tab” on page 422.

When **Ignore Subsection Boundaries** is checked, the Tread Depth value may change when the stair section is edited, but will remain consistent throughout all subsections.

Because the boundaries between stair sections are being ignored, the treads where a straight section joins a curved section may shift position or change angle to accommodate the adjustment.

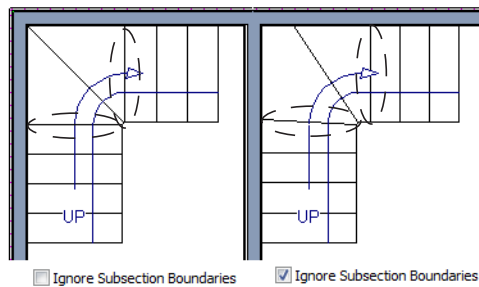

Flared Stairs and Curved Treads



Any stair section can be flared and/or its treads curved using the **Flare/Curve Stairs** edit button.

Only exposed sides of a stair section can be flared. If one side of a stair section is against a wall or wrapped (see “Wrapped Stairs” on page 415), only the exposed end can be flared.



Flaring, curved treads, and special treads should be the last changes that you make to any stairs.

Creating a Flared Stair

Flared stairs grow wider near one end, typically sweeping outward at the bottom. Stairs can also be flared at the top or on both ends.



To create flared stairs

1. Create the stairs and connect them to a landing, floor platform edge, or another stair section.
2. Specify the section width, tread depth, and any other needed information.
3. Select the stairs and click the **Flare/ Curve Stairs**  edit button. New **Flare** edit handles display on all four corners of the stairs.
4. Drag one of the corner handles to flare that corner. As you drag the flare, the Status Bar shows the distance the side handle moves. This allows you to move the opposite handle the same amount.

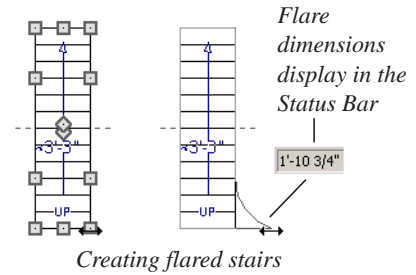

5. When you are finished editing the flare, click the **Main Edit Mode**  to restore the stairs' regular edit handles and toolbar buttons.

Symmetrically Flared Stairs

Use the dimension information that displays in the Status Bar as a reference to create symmetric flares on both sides.

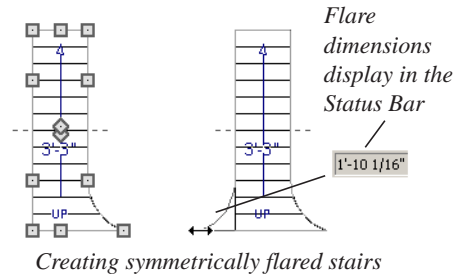

Adjusting the Flare Radius

After a flared staircase has been created, you may want to soften the radius of the flare.

The four handles at the sides and the four handles at the corners flare the stair section when dragged outward. The two handles in the center of the section move the starting point for flaring along the stair section.

To adjust the flare radius

First, adjust the curvature of the flared section.

1. Select the flared stair and click the **Flare/Curve Stairs**  edit button to access the flare handles again.
2. Select the handle along the flared edge of the stair. Drag this handle outward very slightly. This forms a more gradual flare.

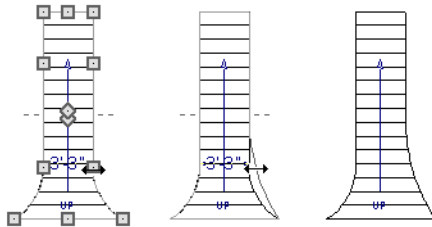

Adjusting the flare curvature

Then, adjust the starting point of the flare:

1. Select the flared stair and click the **Flare/Curve Stairs**  edit button to access the flare handles again.
2. This time, drag the lower of the two central handles upward. The handle above it moves with it. This moves the start point for the bottom flare from the middle of the section toward its top, making the flare even more gradual.

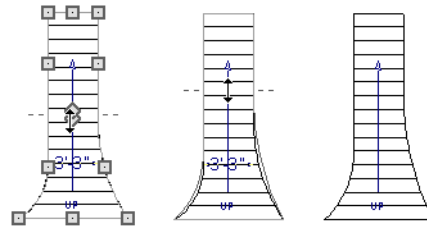

Adjusting the flare's starting point

Treads Perpendicular to Flare

Flared stairs often look best when the treads curve to meet the flared side perpendicular to the radius.

To curve the edges of flared treads

1. Select the flared stair and click the **Flare/Curve Stairs**  edit button to access the flare handles again.
2. Drag a corner edit handle upward one tread depth or less.

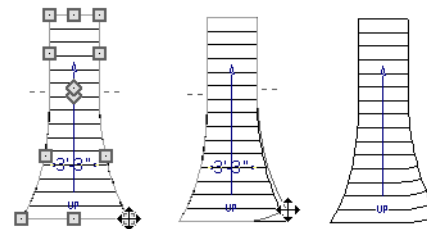

Curving the edges of flared treads

3. When you are finished editing the curve, click the **Main Edit Mode**  to restore the stairs' regular edit handles and toolbar buttons.

This type of tread curving works only on flared edges and concentrates the curvature at that edge.

Flared treads can also be curved using the Curve edit handle, which curves the treads more uniformly.

Curving the Treads

When treads are curved, all treads in the section show some degree of curvature. Treads close to the curved end have a greater curve than those at the opposite end, but both ends can be curved.



To curve stair treads

1. Select the staircase, then click the **Flare/Curve Stairs**  edit button.
2. Drag the edit handle at the center of the bottom edge a small distance to curve the treads.

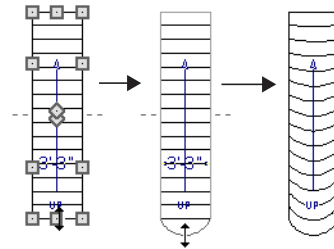

Creating curved stair treads

3. When you are finished editing the curve, click the **Main Edit Mode**  to restore the stairs' regular edit handles and toolbar buttons.

Starter Treads



The first and second treads of a staircase can be turned into starter treads by clicking the **Starter Tread** edit button. Starter treads extend to the side of the staircase, have rounded edges and are common on traditional staircases.

A starter tread can be added only to open sides of a stair section. If one side of a stair section is against a wall or wrapped (see “Wrapped Stairs” on page 415), only the exposed tread end can become a starter tread.



To create starter treads

1. Click on a staircase to select it.
2. Click the **Starter Tread**  edit button. An edit handle displays on each end of both the first and second treads.

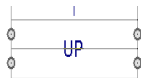

3. Drag either of the handles on the first tread outward from the stair section. If the stair section is against a wall, only one handle displays on the side opposite the wall.
4. As you drag, the ends of the tread become rounded.

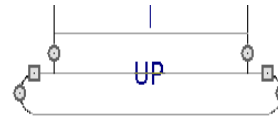

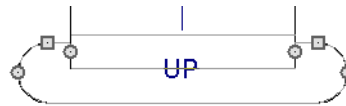

5. Two additional edit handles display on each side of the tread, along the back edge.
6. Drag either of the two square handles upward to increase the width of the rounded ends of the tread.

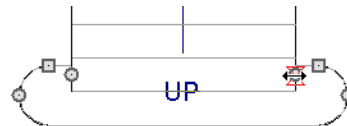

7. Drag the edit handle on the second tread outward from the stair section to create a second starter tread.



8. To make changes to existing starter treads, select the stairs, click the **Starter Tread**  edit button and repeat the above steps as needed.
9. When you are finished editing the starter treads, click the **Main Edit Mode**  to restore the stairs' regular edit handles and toolbar buttons.

Winders

Winders are steps located where a staircase turns and are narrower on the inside of the

turn than they are on the outside. A staircase defined as a winder expands to fill in any

gaps between the side of the stairs and nearby walls.

Curved stair sections are typically used to create winders, although straight stairs can also be used. See “Curved Stairs and Ramps” on page 401.

To create winders

1. In an enclosed room area, place and connect the stair sections that you want to be winders. For best results:
 - The stairs should be two straight sections connected by a curved section between them;
 - The curved section should be adjacent to a 90° corner, as illustrated.
2. Select any subsection of the stairs and click the **Open Object**  edit button to open the **Staircase Specification** dialog.
3. On the General tab, place a check in the box beside **Winder** and click **OK**.

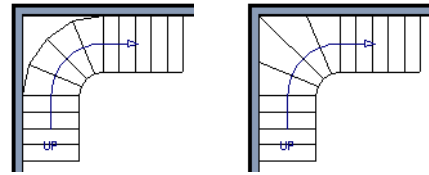

Winders extend to nearby walls

4. The steps nearest the wall corner adjust their shapes and extend into the corner after the stair is changed to a winder.

 Winders must be in a room with valid room definition. You cannot create winders in an area composed of only 2 corner walls. If this configuration is needed, enclose the area in with Invisible walls so that a room area is defined.

The Winders attribute directs the stair section to expand or contract to meet nearby walls, and can also be used to create a partial railing. See “Partial Railings” on page 416.

Winders sometimes have treads that are too narrow at the inside curve. The **Ignore Subsection Boundaries** option can address this issue. See “Ignore Subsection Boundaries” on page 410.

Wrapped Stairs

Check **Allow Wrap** on the Style tab of the **Staircase Specification** dialog and the selected stairs can be wrapped around the corner of a deck or landing. Curved stairs and stairs with multiple subsections cannot be wrapped. See “Style Tab” on page 425.

Stair sections that wrap around a corner to meet one another must have identical

attributes. As a result, edits made to one wrapped stair section apply to all adjacent, wrapped sections.

To wrap stairs around a deck

1. Draw a deck if you have not already done so. See “Decks” on page 238.

2. Use the **Click Stairs**  tool to draw a stair section on each side of the corner around which you want them to wrap.
3. Draw a second set of stairs on the other edge of the deck the same way.
4. If necessary, move the stair sections toward the corner of the deck. The two sections merge to form wrapped steps.

 You can also draw stairs down from a deck by right-clicking to draw them or by pressing the Alt key while you drag. See “To draw stairs going downward” on page 402.



To wrap stairs around a landing

1. Draw two perpendicular **Straight Stair**  sections.
2. Click between them to create a landing.
3. Rotate one stair section 180°.

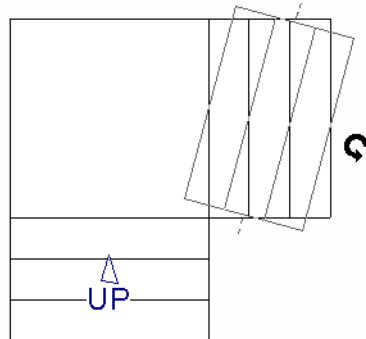

4. The stairs wrap around the corner. Notice that the Up arrow displays on the most recently edited stair section.

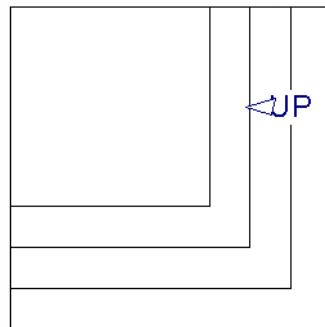

Other Special Railings & Stairs

Stairs can be customized to meet a variety of needs.

Partial Railings



A staircase can be enclosed on one side by a combination of wall and railing.



Partial railings can be created by specifying the stairs as winders and increasing the **Max Tread Contraction** in the **Staircase Specification** dialog. See “Style Tab” on page 425.

The **Max Tread Contraction** defines the largest distance that any section of the stair system is allowed to move *inward* when the stairs are turned into winders. If any point on the edge of the stairs would have to move inward more than this defined amount in order to locate the surface of the wall, the stairs do *not* contract and snap to that wall.

To create a partial stair railing

1. Create a staircase and draw an **Interior Wall**  against, but not underneath, the stairs.
2. Select the stairs and click the **Auto Stairwell**  edit button to create a stairwell.
3. On the General tab of the **Staircase Specification** dialog, check **Winders**.
4. On the Style tab, define the **Max Tread Contraction (for Winder)**. If the inte-

rior wall is 4" thick, setting this value to 4" should be sufficient.

5. On the Style tab, increase the **Stringer Bottom** value to enclose the area under the stairs with railings. The best value depends on the design of your stairs.
6. On the Newels/Balusters tab, remove the check from either **Right** or **Left Railing at Wall**, depending on the position of the stairs and wall in your plan.
7. Click the **Object Snaps**  toggle button to temporarily turn off Object Snaps. See “Object Snaps” on page 110.
8. Select the stairs and use the side edit handle to move the edge of the stairs to approximately the middle of the wall.

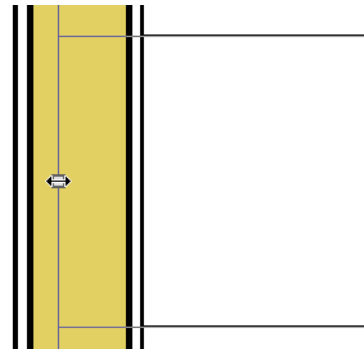

Resizing stairs to the middle of the wall

9. You may need to **Zoom**  in on the stairs and wall to move the stair edge.

Solid Railings

To create a solid rail along a staircase, create the Railing against, but not underneath, the stairs and specify it as Solid. See “Rail Style Tab” on page 224.

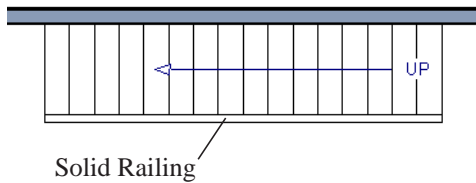

The solid railing recognizes the adjacent stairs and climbs alongside them.



If any balusters show beyond the railing, eliminate them by unchecking **Left railing** or **Right railing** in the **Staircase Specification** dialog. See “Style Tab” on page 425.



Railing Panels

You can use railing panels, including glass panels or cable, as stair railing instead of newels and balusters by drawing a

Railing  under the stairs or ramp.

To use railing panels with stairs

1. Create a staircase and draw a **Railing**  under the stairs.
 - Make sure that the railing is located entirely within a single stair section.

- Position it so that it is aligned with the left edge.
2. Select the railing and click the **Open Object**  edit button. See “Wall Specification Dialog” on page 214.
 3. On the Rail Style tab of the **Railing Specification** dialog,
 - Select the **Panels** radio button.
 - Check **Follow Stairs**.
 4. On the Newels/Balusters tab, click the **Browse** button to the right of **Panel Type** and select the railing panel you want to use on the stairs, then click OK.
 5. Select the staircase and click the **Open Object**  edit button.
 6. On the Newels/Balusters tab of the **Railing Specification** dialog, uncheck **Left Railing** to prevent the default stair railing from generating in addition to the railing panel.
 7. Repeat these steps if you want railing panels under the right side of the stairs, as well.

Concrete Stairs



To make a solid concrete staircase

1. On the Style tab of the **Staircase Specification** dialog:
 - Set the **Tread Overhang** to zero.

- Set the **Tread Thickness** to zero.
 - Uncheck **Open Risers**.
 - If you want, you can also uncheck **Open Underneath** and check **Large Stringer Base**.
2. On the Materials tab, specify the “Riser/Trim”, “Support Wall”, and “Tread” materials as concrete.

Masonry Stairs



To make a set of masonry stairs

1. On the Style tab of the **Staircase Specification** dialog:
 - Set the **Tread Overhang** to zero.
 - Set the **Tread Thickness** to the thickness of the masonry material.

Steel Stringer



To make a steel stringer with concrete treads

1. On the Style tab of the **Staircase Specification** dialog,
 - Check **Open Underneath**.
 - Select the **Single Stringer** check box.
 - Set the **Tread Thickness** to 2 inches or more.
 - Select the **Single Stringer** check box.
2. On the Materials tab, specify the “Tread” material as concrete and the “Riser/Trim” material as steel.

Creating a Stairwell

An interior staircase must be located in a stairwell, an opening to the floor above. A stairwell is an Open Below room type on the floor above. See “Room Types” on page 234.

If you create a stairwell away from other walls so the Open Below is created in the center of another room, connect a wall of the Open Below room to another wall using an invisible wall.

Creating a Stairwell Automatically





To create a stairwell that matches the perimeter of a selected staircase, click the **Auto Stairwell** edit button. This button is only available when a living space exists above the staircase. It will not be available if the space above is Open Below or on the Attic Floor.

Auto Stairwell  automatically creates a room on the floor above enclosed by railings, defined as **Open Below** in the **Room Specification** dialog, and given a **Stairwell** room label. This room can be selected and edited like any other room.

Creating a Stairwell Manually

Stairwells can also be created manually.

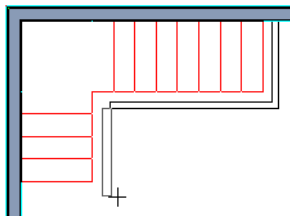

To create a manual stairwell

1. Draw a two-story building. Create the staircase on the first floor.
2. Make the second floor the **Current Floor** and the first floor the **Reference Floor**. See “The Reference Floor” on page 327.
3. Select **Tools> Reference Floors> Reference Display**  to show the Reference Floor, including the stairs.
4. On the upper floor, use the **Railing**  tool to create a room around the stairs. Use the edit handles to position the railings as needed.



5. Select the railings one at a time and move them into position.
 - When a railing is selected, its bounding box shows the location of the outer sur-

face of the railing’s drywall layer. For best results, this outer surface (which does not display when the railing is not selected) should meet the top edge of the stairs. See “Wall Types and Railings” on page 186.

- If you prefer, you can also go **Down One Floor** and adjust the top edge of the staircase to snap it to the surface of the railing on the floor above.
6. When the railings are positioned properly, select **Tools> Reference Floors> Reference Display**  to turn off the display of the Reference Floor.
 7. Click inside the room using the **Select Objects**  tool to select it, then click the **Open Object**  edit button.
 8. On the General tab of the **Room Specification** dialog, select “Open Below” from the **Room Type** list. Click **OK** to close the dialog.

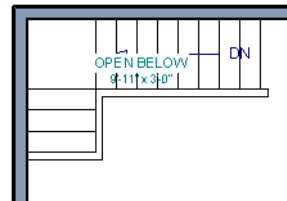



9. Place a **Doorway**  in the railing at the top step for an opening.
10. Select the doorway and define a large width in the **Door Specification** dialog. If the doorway is specified wider than the railing, its width maximizes to fit the space available.



Rooms Below Staircases

Rooms such as closets or storage areas are commonly located beneath staircases.

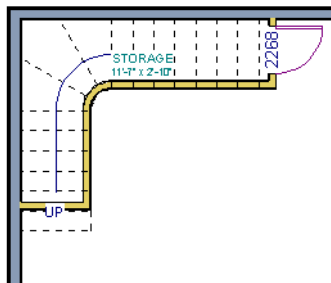

To create a room below a staircase

1. Draw a staircase, select it, and click the **Open Object**  edit button to open the **Staircase Specification** dialog.
 - If Winders are specified for this staircase, set **Max Tread Contraction** to 2" on the Style tab to allow walls to be built entirely under the staircase.
2. On the same floor as the staircase, draw the **Interior Walls**  under them, following their shape.
3. Reposition the walls as needed, making sure that each is entirely under the stairs.
4. The wall at the foot of the stairs should be placed no closer to the bottom than the second step.
5. Add a door and specify the Room Type.



Staircase Specification Dialog

 Staircases can be defined with the greatest accuracy using the **Staircase Specification** dialog. To open the **Staircase Specification** dialog, select a stair section and click the **Open Object** edit button or double-click a stair section using the

Straight Stairs  or **Select Objects**  tool.

If a staircase is composed of multiple stair sections, the section that you clicked on to select the staircase is the Selected Section; however, information about all the sections is available and can be edited in this dialog.

 It is recommended that all floor heights, ceiling heights and platform thicknesses be established before using the Staircase Specification dialog.

General Tab

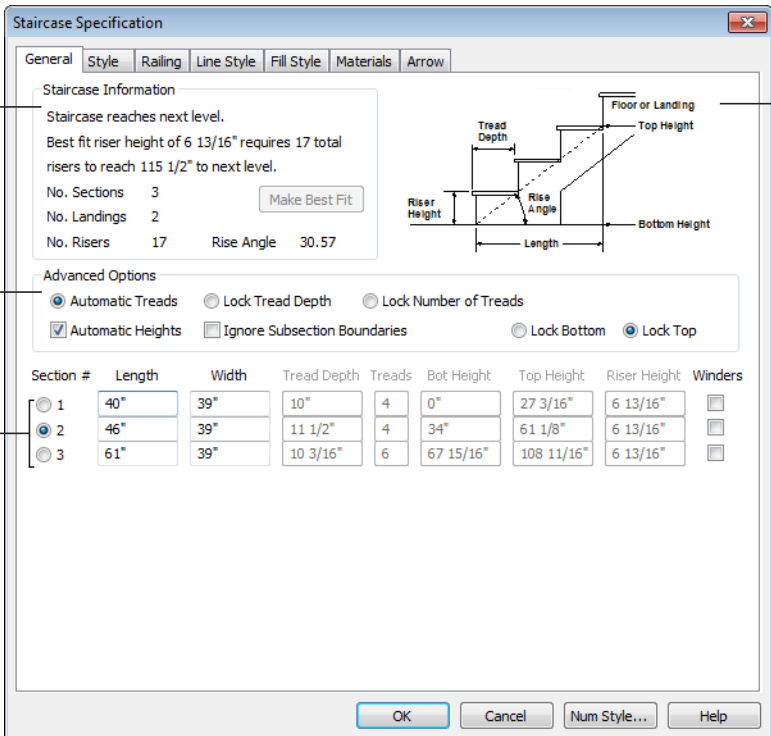

Staircase Information

Staircase reaches next level.
 Best fit riser height of 6 13/16" requires 17 total risers to reach 115 1/2" to next level.
 No. Sections 3 Make Best Fit
 No. Landings 2
 No. Risers 17 Rise Angle 30.57

Advanced Options

Automatic Treads Lock Tread Depth Lock Number of Treads
 Automatic Heights Ignore Subsection Boundaries Lock Bottom Lock Top

Section #	Length	Width	Tread Depth	Treads	Bot Height	Top Height	Riser Height	Winders
1	40"	39"	10"	4	0"	27 3/16"	6 13/16"	<input type="checkbox"/>
2	46"	39"	11 1/2"	4	34"	61 1/8"	6 13/16"	<input type="checkbox"/>
3	61"	39"	10 3/16"	6	67 15/16"	108 11/16"	6 13/16"	<input type="checkbox"/>

OK Cancel Num Style... Help

① **Staircase Information** - Structural information about the selected staircase displays here. This information cannot be edited directly, but updates as changes are made in the dialog. If you modify a value elsewhere, press the **Tab** key to update this information.

- The first comment tells whether or not the staircase reaches the next level, which may be a floor platform or locked landing. It also indicates whether its rise angle is either steeper or more shallow than the Best Fit, described below. If **Automatic Heights** is unchecked, this comment instead says “Start and end heights are set manually”.
- The second comment, **Best fit riser height of ___ requires ___ total risers to reach ___ to next level**, describes the ideal rise and run for the selected staircase. The program defines the Best Fit Riser Height as the riser height closest to 6 3/4” (168.75 mm) that allows the selected staircase to meet the next level precisely. This comment is only active if **Automatic Heights** is checked, below.

If the staircase includes a locked landing, its height is used to calculate this information. See “Locked Landings” on page 408.

- The total number of stair **Sections**, **Landings**, and **Risers** associated with the selected staircase also display here.
- The **Rise Angle** of the currently active stair section also displays here.
- Click the **Make Best Fit** button to add or remove risers to the Selected Section. Only available when **Automatic Heights** is checked and the staircase does not currently use the Best Fit Riser Height.

Make Best Fit will also extend stairs drawn in a downward direction until they reach the terrain. See “Terrain Perimeter” on page 538.

② The **Advanced Options** apply to all sections and subsections.

Automatic Treads, Lock Tread Depth, and Lock Number of Treads affect how treads are calculated. Only one of these options can be selected at a time.

- Select **Automatic Treads** to have the program define the depth and number of stair treads. If the staircase has multiple sections, each may have different tread depths.
- Select **Lock Tread Depth** to specify the Tread Depth for each stair section, below, and prevent them from changing. When Lock Tread Depth is selected and the length of the stairs is changed, the number of treads will change.
- Select **Lock Number of Treads** to specify the number of treads in each stair section and prevent it from changing. When Lock Number of Treads is selected and the length of the stairs is changed, the tread depths will change.
- Uncheck **Automatic Heights** if you would like to specify the bottom and top heights of each stair section, as measured from the default floor height of Floor 1, 0” (mm). When checked, the program automatically defines the top and bottom heights by precisely locating floor platforms and landings.
- Check **Ignore Subsection Boundaries** to maintain tread depth throughout a stair section composed of merged subsections, regardless of whether the subsections have different tread depths assigned to

them. See “Ignore Subsection Boundaries” on page 410.

Lock Bottom and Lock Top are actions rather than settings. If you make changes to the staircase that will affect its length, first lock either the bottom or top end of the Selected Section to prevent it from moving. The height of the Selected Section’s locked end is not affected by these settings - only its position on the X/Y axis.

- Select **Lock Bottom** to lock the position of the selected stair section’s bottom end to prevent it from moving. Sections and landings below the selected section do not move when you click OK, while those above do move.
- Select **Lock Top** to lock the position of the selected stair section’s top end to prevent it from moving. Sections and landings above the selected section do not move when you click OK, while those below do move.

 If you select a staircase by clicking near its bottom end, Lock Top will be selected; if you select it near its top end, Lock Bottom will be selected.

3 The specifications for each stair section and subsection display and can be edited here. A maximum of ten items can display.

A change in one value usually affects other values. You may need to reposition the staircase after making changes.

- The **Section #** column identifies the Selected Section and the number of each section of the selected staircase. If **Ignore Subsection Boundaries** is unchecked, subsection numbers are also identified. The radio button to the left indicates

which section or subsection is selected. See “Displaying Stairs, Ramps, and Landings” on page 402.

- Define the **Length**, or run, of each section or subsection measured along the Walk Line. The length is equal to the number of treads multiplied by the tread depth. See “Walk Line” on page 409.

When the length of a section changes, other sections and landings in the staircase unit move in response. You can specify whether the bottom or top edge of the Selected Section moves when you resize it by selecting either the Lock Bottom or Lock Top radio button, above.

- Define the **Width** of each section. Only one width can be defined for a section, so all subsections in the same section have the same width. If a section is connected to a landing, its width should equal the length of the landing edge that it connects to. See “Landings” on page 406.
- Specify the **Tread Depth**, or run, of each stair tread in the selected section. To lock this value, check **Lock Tread Depth**, above.

If a landing is created by clicking between two stair sections and one of them has locked tread depth, the resulting staircase also has locked tread depth. Any landings or sections connected to this new staircase adjust to meet it and then have locked tread depth as well.

- Define the number of **Treads** in a stair section or subsection. To lock this value, select Lock Number of Treads, above.
- Define the **Bottom Height**, the height of the stair section’s bottom edge. To lock this value, click the radio button to the left of the section’s number, then click the

- Lock Bottom radio button, above, and click OK.
 - Define the **Top Height**, the height of the stair section's top edge. To lock this value, click the radio button to the left of the section's number, then click the Lock Top radio button, above, and click OK.
 - Define the **Riser Height**, the height of the risers in each stair section.
 - Check **Winders** to specify the Selected Section as winders. This affects the section as a whole, including subsections. See "Winders" on page 414.
- 4 A diagram of a sample staircase's structure displays here for reference.

Style Tab

The settings on the Style tab affect all stair sections and subsections.

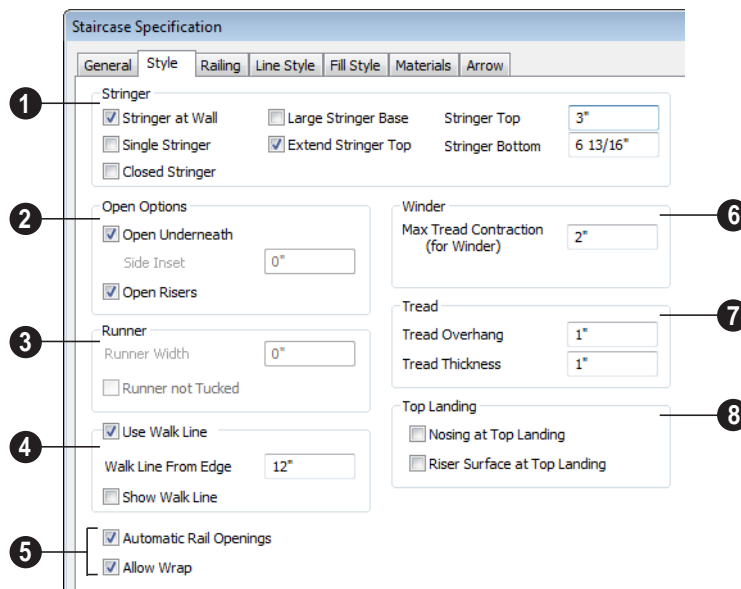

- 1 Specify the attributes of the selected staircase's **Stringers**, which are the angled support members that support the treads. See "Anatomy of a Staircase" on page 399.
- Check **Stringer at Wall** to produce a raised stringer top baseboard at the sides

of the stair sections against walls. This baseboard follows the slope of the stair.

- Check **Single Stringer** to form a single 5-inch (125 mm) thick stringer in the center of the staircase.

Checking **Single Stringer** automatically checks **Open Risers** and unchecks

Stringer at Wall and Closed Stringer.

You may want to increase the tread thickness when this is checked.

- Check **Closed Stringer** to raise the tops of the exposed stringers to cover the sides of the treads. If this is checked, no central stringer is applied to open riser stairs. This setting only affects those stringers that are not against a wall.
- Check **Large Stringer Base** to widen the stringers at the foot of the staircase. This is helpful when walls are created below the stairs.

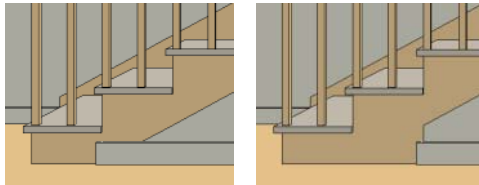

Large Stringer Base shown at right

- **Extend Stringer Top** is checked by default and extends a triangular portion of the stringer under the landing or platform at the top of the stairs.
 - Specify the height of the **Stringer Top** when **Stringer at Wall** or **Closed Stringer** is selected. This is measured along the plane of the riser face from the top of a tread to the top of the stringer. It cannot be less than 2 inches (5 cm).
 - Specify the height of the **Stringer Bottom**. This is measured from the top back corner of a tread down to the bottom edge of the stringer. It must be equal to or greater than the riser height.
- 2** **The Open Options** control whether the selected stairs have open risers or an open underside.

- Uncheck **Open Underneath** to add a skirt below the staircase along the two sides. It looks like a wall in 3D, but it has only a single face. Base molding does not generate along the bottom of the skirt, and doors cannot be placed in it.
- Specify the **Side Inset** of the skirt below the staircase. The default value of 0 aligns the skirt with the outside of the surface of the stringers. Only available when **Open Underneath** is unchecked.

In most cases, the recommended way to enclose the area beneath stairs is to use walls. See “Rooms Below Staircases” on page 421.

- Check **Open Risers** to eliminate the riser face under each tread and expose the stringers. If **Closed Sides** is also selected, no central stringer is supplied.
- 3** Specify the attributes of the staircase’s carpet **Runner**. A runner is added to all sections connected by unlocked landings. Only available when **Open Risers** is unchecked, above.
- Specify the **Runner Width**. The default value of 0 does not create a runner. Only available when **Open Risers** is unchecked, above.
 - Check **Runner not Tucked** to have the runner drop straight down from the tread front to the riser below. This is unchecked by default.
- 4** Check **Use Walk Line** to have the program calculate the tread depth based on a Walk Line. Uncheck the box to disable this function. See “Walk Line” on page 409.
- Specify the distance of the **Walk Line from Edge**. The default value is 12” (300 mm).

- Check **Show Walk Line** to show the Walk Line in floor plan view.
- ⑤ Additional options control the behavior and appearance of the staircase.
- Check **Automatic Railing Openings** to automatically create a doorway opening when the selected stairs are snapped to a railing drawn on the same floor as the stairs. This is checked by default.
- Check **Allow Wrap** to wrap the selected stairs around the corner of a deck or landing where another, identical stair section is present. See “Wrapped Stairs” on page 415.
- ⑥ Define the **Max Tread Contraction (for Winder)** value, which is the amount a tread’s width may be reduced when it meets a wall. See “Partial Railings” on page 416.

This option only takes effect when the stairs are specified as **Winders** on the General tab.

- ⑦ Specify the characteristics of the staircase **Treads**. See “Anatomy of a Staircase” on page 399.
 - Specify the **Tread Overhang**, which is the distance that each tread overhangs the riser.
 - Specify the **Tread Thickness**.
- ⑧ Specify the appearance of the staircase where it meets the **Top Landing**. The edges of landings are not affected by these options.
 - Check **Nosing at Top Landing** to produce tread nosing attached to platform edge at the top of stairs.
 - Check **Riser Surface at Top Landing** to produce a riser surface against the platform edge at the top of the stairs. This allows stair risers to match all the way to the top of the platform.

Railing Tab

The settings on the Railing tab can also be found in the **Ramp Specification** dialog and will affect the appearance of railings on any

landings attached to the selected staircase or ramp. See “Landings” on page 406.

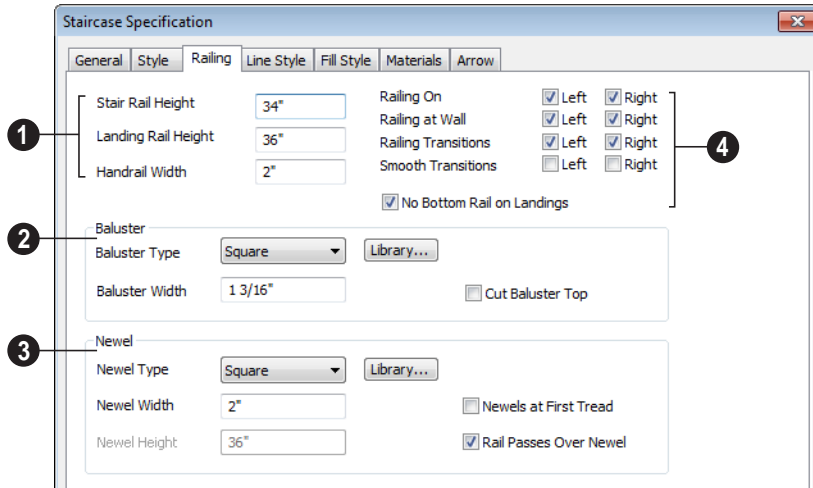

1 Specify the height and width of stair and landing rails.

- **Stair Rail Height** defines the height from tread surface directly over the riser to railing top.
- **Landing Rail Height** defines the height of the landing rail top from the landing surface.
- **Handrail Width** defines the horizontal width of the handrail used by the selected staircase and any attached landings.

2 **Baluster** specifications.

- **Baluster Type** - Select **Square**, **Round**, or **Library** balusters. Selecting **Library** from the drop-down list is the same as clicking the **Library** button to the right and allows selection of a baluster from the library.
- Specify the **Baluster Width**, which is the width or diameter of each baluster. For

Library balusters, this is the width at its widest point.

- **Cut Baluster Top** - Each tread normally has two to three balusters, growing longer toward its back. The default is to use the same baluster and cut it off at the bottom to shorten it toward the tread front. Check this box to cut the balusters at the top instead.

3 **Newel** specifications.

- **Newel Type** - Select **Square**, **Round**, or **Library** newels. Selecting **Library** from the drop-down list is the same as clicking the **Library** button to the right and allows selection of a newel from the library.
- Specify the **Newel Width**, which is the width or diameter of each newel. For Library newels, this is the width at its widest point.
- Specify the **Newel Height**, which is the height from the landing surface to the top

of the newel. This is used only when **Rail passes over Newel** is unchecked.

- Check **Newels at First Tread** to place a newel where the rail starts at the base of the stairs. A newel is placed only on a side of the stairs not against a wall.
- Uncheck **Rail Passes Over Newel**, then adjust the **Newel Height** to as needed. When this is checked, the **Newel Height** setting is ignored.

4 Railing specifications.

- **Railing On** - Select **Left** and/or **Right** to specify placement of railings on stair sections.
- **Railing at Wall** - Select **Left** and/or **Right** to specify the placement of wall railings. Not available for ramps.

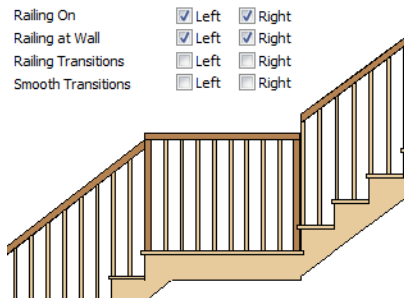

- Check **Railing Transitions** to create “gooseneck” connections between stair and landing railings. This option only has an effect when **Rail Passes Over Newel** is checked. Not available for ramps.

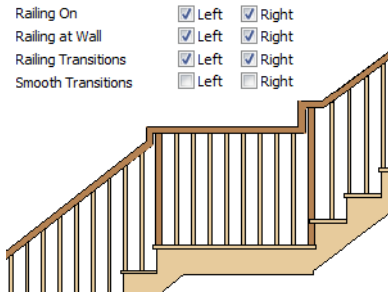

- Check **Smooth Transitions** to specify the placement of smooth connections between stair and landing railings. Not available for ramps.

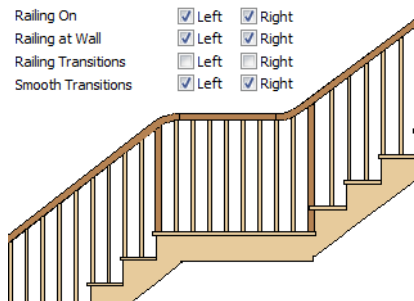

Check both **Railing Transitions** and **Smooth Transitions** to produce a handrail like this:

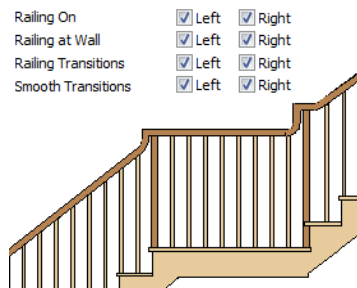

- Check **Include Bottom Rail on Landings** to place a low rail on the landing surface that receives the balusters ends.

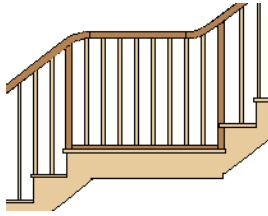

Line Style Tab

The settings on the Line Style tab are available for a variety of other objects in the program. For information about these settings, see “Line Style Tab” on page 781.

Fill Style Tab

The settings on the Fill Style tab affect the appearance of the selected staircase in floor plan view. For information about these settings, see “Fill Style Tab” on page 792.

Materials Tab

The settings on the Materials tab affect the appearance of the selected staircase in 3D views and are available for a variety of objects throughout the program. For information about these settings, see “Materials Tab” on page 635.

The settings on this tab will also affect the materials applied to any landings attached to the selected staircase. See “Landings” on page 406.

Arrow Tab



The settings on the Arrow tab control the appearance of the selected staircase’s direction arrow in floor plan view. See “In Floor Plan View” on page 402.

For information about these settings, see “Arrow Tab” on page 783.

Ramp Specification Dialog



Ramps can be defined with the greatest accuracy using the **Ramp Specification** dialog. To open this dialog, select one or more ramps and click the **Open**

Object edit button or double-click a ramp section using the **Ramp**  or **Select Objects**  tool.

General Tab

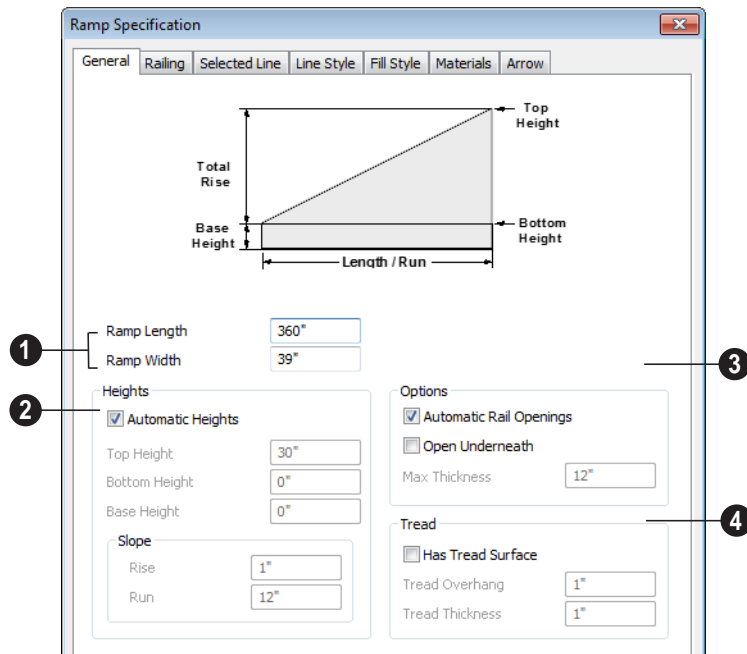

1 Specify the **Ramp Length** and **Width**.

2 Uncheck **Automatic Height** to activate the settings below, then specify the height and slope of the ramp.

- Specify the **Start Height**, which is the height of the ramp's at its low end.
- Specify the **End Height**, which is the height of the ramp at its high end.
- Specify the ramp's **Slope (Rise/Run)** in the form of a ratio. Type the **Rise** value in the first field, and the corresponding **Run** value in the second field.
- Specify the **Base Height**, which is the height of the bottom surface of the ramp.

3 **Options** -

- Check **Automatic Railing Openings** to automatically create a doorway opening when the selected ramp is snapped to a railing drawn on the same floor as the ramp. This is checked by default.
- Check **Open Underneath** to remove the skirt around the bottom of the ramp so that it has a uniform, sloped thickness that may not reach the floor or terrain at the high end. This is unchecked by default.
- Specify the **Max Thickness**, which is the ramp's maximum thickness. At the low end of the ramp, where it meets the floor or terrain, its thickness may be less than this value.

4 Specify the structure of the ramp's **Tread**, which is an optional surface layer placed over the top of the ramp.

- Check **Has Tread Surface** to apply a top tread surface to the ramp and enable the settings below.
- Specify the **Tread Overhang**, which is the distance the tread surface extends past the ramp's edges.
- Specify the **Tread Thickness**, which is the tread surface's vertical depth.

Railing Tab

The settings on the Railing tab are similar to those on the same tab in the **Staircase Specification** dialog. For information about these settings, see "Railing Tab" on page 427.

Selected Line Tab

The Selected Line tab is available when the selected ramp section is straight as opposed to curved. See "Selected Edge" on page 125.

The settings on this tab are available for a variety of other objects in the program. For information about the settings on this tab, see "Line Tab" on page 780.

Selected Arc Tab

The Selected Arc tab is available only when the selected ramp section has been converted to an arc. See "Change Line/Arc" on page 159.

The settings on this tab are available for a variety of other objects in the program. For

information about these settings, see "Arc Tab" on page 787.

Line Style Tab

The settings on the Line Style tab are available for a variety of other objects in the program. For information about these settings, see "Line Style Tab" on page 781.

Fill Style Tab

The settings on the Fill Style tab affect the appearance of the selected ramp in floor plan view. For information about these settings, see "Fill Style Tab" on page 792.

Materials Tab

The settings on the Materials tab affect the appearance of the selected ramp in 3D views and are available for a variety of objects throughout the program. For information about these settings, see "Materials Tab" on page 635.

The settings on this tab will also affect the materials applied to any landings attached to the selected ramp. See "Landings" on page 406.

Arrow Tab

The settings on the Arrow tab control the appearance of the selected ramp's direction arrow in floor plan view. See "In Floor Plan View" on page 402.

For information about these settings, see "Arrow Tab" on page 783.

Stair Landing Specification Dialog



Select a landing and click the **Open Object** edit button to open the **Stair**

Landing Specification dialog. See “Landings” on page 406.

General Tab

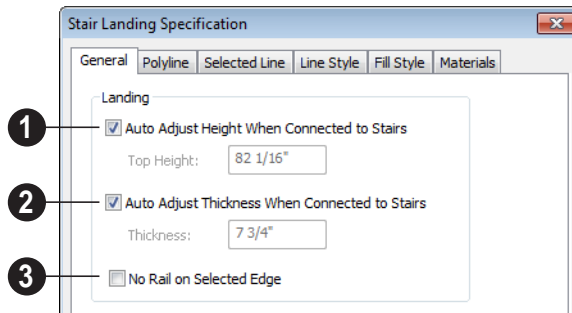

- 1 Uncheck **Auto Adjust Height When Connected to Stairs** to specify the selected landing’s **Top Height**.
 - A free-standing interior landing will have a default **Top Height** of 6 3/4” (169 mm) plus the thickness of the default floor finish. A free-standing exterior landing will have a default top height equal to its thickness. When this box is checked, the landing height may adjust as needed to maintain consistent riser height in all connected stair sections.
 - The **Top Height** field is only active when **Auto Adjust Height When Connected to Stairs** is unchecked. See “Locked Landings” on page 408.
- 2 Uncheck **Auto Adjust Thickness When Connected to Stairs** to specify the selected landing’s **Thickness**.
 - A free-standing landing will have a default thickness of 6 3/4” (169 mm).

When checked, the thickness is based on the riser height of the stair sections it is attached to, or the thickness of the ramps it is attached to.

- The **Thickness** field is only active when **Auto Adjust Thickness When Connected to Stairs** is unchecked.
- 3 Check **No Rail on Selected Edge** to suppress the railing on the selected edge of this landing. See “Selected Edge” on page 125.

Polyline Tab

The Polyline tab indicates the length of the landing’s **Perimeter**, its enclosed **Area**, and its **Volume**.

The settings on the this tab are available for a variety of other objects in the program. For information about the settings on this tab, see “Polyline Tab” on page 792.

Selected Line Tab

The Selected Line tab is available when the selected edge is a line as opposed to an arc. See “Selected Edge” on page 125.

The settings on this tab are available for a variety of other objects in the program. For information about the settings on this tab, see “Line Tab” on page 780.

Moving the Start of a line segment moves the end of the previous connected line. Similarly, moving the End of a line segment moves the start of the next connected line.

Selected Arc Tab

The Selected Arc tab is available only when the selected edge has been converted to an arc. See “Change Line/Arc” on page 159.

The settings on this tab are available for a variety of other objects in the program. For information about these settings, see “Arc Tab” on page 787.

Line Style Tab

The settings on the Line Style tab are available for a variety of objects throughout the program. For information about these settings, see “Line Tab” on page 780.

Fill Style Tab

The settings on the Fill Style tab affect the appearance of the selected landing in floor plan view. For information about these settings, see “Fill Style Tab” on page 792.

Materials Tab

When a landing is attached to stairs or a ramp, its initial materials are derived from the stairs or ramp. When the landing is attached to a ramp, its top surface material is defined by the Landing Sides component unless the ramp is using a Tread material.

The settings on this are available for a variety of objects throughout the program. For information about these settings, see “Materials Tab” on page 635.

Framing

In Home Designer Pro, framing can be produced both manually and automatically, and can be calculated in the Materials List.

Manual framing members are drawn by clicking and dragging, like drawing a CAD line. Automatic framing for the major components of a 3D model (floors, ceilings, walls and roofs) can be generated using the **Build Framing** dialog.

Both manually drawn and automatically generated framing members can be selected and edited in 2D and 3D views.

Trusses are covered in their own chapter, “Trusses” on page 469.

Chapter Contents

- Framing Defaults
- Manual vs. Automatic Framing
- The Framing Tools
- Build Framing Dialog
- Framing Reference Markers
- Bearing Lines
- Joist Direction Lines
- Displaying Framing
- Editing Framing
- Keeping Framing Current
- Framing and the Materials List
- Framing Specification Dialog
- Post Specification Dialog

Framing Defaults



Select **Edit > Default Settings** to open the **Default Settings** dialog. Select Framing from the list, then click the **Edit** button to open the **Framing Defaults** dialog.

Both automatic and manually-drawn framing are generated according to the settings in the **Framing Defaults** dialog.

This dialog is nearly identical to the **Build Framing** dialog in both appearance and function. The only difference is that the **Build Framing** dialog has checkboxes that allow you to automatically generate different types of framing in your plan. See “Build Framing Dialog” on page 443.

Any changes made in the **Framing Defaults** or **Build Framing** dialogs will affect subsequently drawn or generated framing, but not framing already present in the plan.



The settings in the Framing Defaults dialog directly affect a variety of important structural elements in each plan which determine floor, ceiling and roof heights; so it is best to set your Framing Defaults before building your model. See “Drawing a Plan” on page 33.

Floor and Ceiling Framing

Floor and ceiling platform depths contribute to the overall height of a structure, so their default values should be set as early as possible. See “Floor Tabs” on page 443.

If you plan to draw floor trusses, also see “Trusses Tab” on page 453.

The default floor and ceiling platform settings for a given floor can be overridden on a room by room basis in the **Room Specification** dialog, or for individual

platforms using **Joist Direction**  lines. See “Structure Tab” on page 245 and “Joist Direction Lines” on page 457.

Deck rooms have special framing generated in them automatically and are not affected by the settings in the **Framing Defaults** or **Build Framing** dialogs. See “Decks” on page 238.

Wall Framing

Like other types of framing, wall framing is generated based on settings in the **Framing Defaults** dialog. See “Wall Tab” on page 446, “Openings Tab” on page 448 and “Headers Tab” on page 448.

In addition, wall framing is dependent on settings from other sources:

- The wall type definition settings used by each wall type in the plan. See “Wall Type Definitions Dialog” on page 211.
- The definition of the framing material assigned to each wall type used in a plan. See “Material Types” on page 640.
- The structural specifications for individual walls in the plan. See “General Tab” on page 214.

In order for wall framing to automatically generate, a wall’s framing layer must be set as its Main Layer and its framing material just be a Framing type. See “The Main Layer” on page 209.

Rough Openings

The rough openings for doors, windows, and fireplaces are set in their respective defaults and specification dialogs. See:

- “Door Specification Dialog” on page 265
- “Window Specification Dialog” on page 294
- “Fireplace Specification Dialog” on page 345

Treated Sill Plates

Treated sill plates automatically generate over all exterior walls that have either Concrete or Brick material type as their Main Layer material and support a floor platform or a framed wall directly above. See “The Main Layer” on page 209 and “Material Types” on page 640.

These sill plates are placed on the “Framing, Floor” layer and are specified as **Treated**. See “Displaying Framing” on page 458.

When a monolithic slab foundation is created, the bottom plates of framed walls built on the slab are specified as **Treated** and are placed on the “Framing, Wall” layer.

Multiple bottom plates can be specified in the **Framing Defaults** dialog, but only the bottommost plate is specified as **Treated**. See “Wall Tab” on page 446.

The default size of treated sill plates is specified in the **Foundation Defaults** dialog. See “Foundation Tab” on page 331.

Roof Framing

Settings on the Roof and Trusses tabs of the **Framing Defaults** dialog determine the structure of roof planes and manually drawn ceiling planes as well as how they rest on bearing walls, so it is important that their default values be set before building the roof. See “Roof Tab” on page 451 and “Trusses Tab” on page 453.

If changes are made to these defaults that you need to apply to the entire roof plan, you will need to rebuild the entire roof - not just the roof framing. See “Roofs” on page 349.

Framing Types

By default, all framing is set to use “Lumber” as the material type. You can select from a number of other types, however, including Glulam and steel. See “Framing Member Types” on page 463.

Manual vs. Automatic Framing

Platform, roof, and wall framing can be produced manually or automatically. In most cases, automatically-generated framing is preferable because it is faster than manually placing, replicating and editing numerous individual framing members.

In many plans, though, framing is drawn using both approaches. For example, a combination of automatically generated rafters and manually drawn trusses can be used to model a roof framing plan. See “Mixing Trusses with Stick Framing” on page 475.

Regardless of how it is created, individual framing members can be selected and edited. See “Editing Framing” on page 460.

Automatic Framing

Automatic framing of floor and ceiling platforms, walls and roofs can be generated using the **Build Framing** dialog. The settings in this dialog control the size, spacing, and type of framing drawn in a plan, and related structural information for the major components of the 3D model. See “Build Framing Dialog” on page 443.

Automatic framing of a particular structural component is not generated until the **Build Framing** dialog is opened to the appropriate tab and one of two checkboxes selected:

- Select the **Build** checkbox to build automatic framing once. For example, check **Build Wall Framing** on the Wall tab, then click OK to build wall framing once based on the current state of the model.
- Select the **Automatic** checkbox, then click OK to build automatic framing every time a change is made to that structural component in the plan. For example, check **Automatic Wall Framing** on the Wall tab to rebuild all wall framing any time a wall is affected by changes to the model.



Note: When Automatic framing of a particular type is enabled, framing of that type cannot be manually edited or deleted.

Manual Framing

Framing objects can also be drawn manually. With the exception of Posts, framing objects are drawn by clicking and dragging in a

straight line, the way other line-based objects are. See “Draw Line” on page 776.

The manual framing tools are organized into families: general framing, floor and ceiling framing and roof framing. The family that a drawing tool belongs to determines where it can be used:

- Roof framing objects can only be drawn within the area of one or more roof planes.
- Floor and ceiling framing objects can only be drawn within one or more floor or ceiling platforms.
- **General Framing**  objects and **Posts**  can be drawn anywhere in a model.

Rebuilding Framing

It is important to remember that by default, framing does not update automatically when changes are made to the model. For example, if a window is moved or resized, the wall framing must be rebuilt. If the footprint is enlarged, the wall framing and any roof or platform framing that is affected must be rebuilt.

You can direct the program to rebuild the automatic framing of floors/ceilings, walls and/or roofs every time a change to the model affects one of these components. To do this, select the **Automatic** checkbox on the Floor, Wall and/or Roof tabs of the **Build Framing** dialog.

To learn more, see “Keeping Framing Current” on page 461.

When automatic framing associated with a particular tab in the **Build Framing** dialog is

built, any previously existing automatically produced framing of the same type is deleted and replaced.

With the exception of wall framing, manually drawn framing is unaffected when automatic framing is rebuilt and remains along with the newly produced automatic framing. By default, manually drawn wall framing is deleted when automatic framing is rebuilt; however, you can prevent this from occurring by checking **Retain Wall Framing** in the **Wall Specification** dialog. See “General Tab” on page 214.

Mixing Rafters and Trusses

If you plan to mix roof trusses with rafters and/or ceiling joists, you can save time by:

- Check **Trusses (No birdsmouth)** in the **Build Roof** dialog before automatically building or manually drawing a roof. See “Build Roof Dialog” on page 355.
- Draw and position all roof trusses before using the automatic framing generator to produce rafters and ceiling joists. See “Floor and Ceiling Trusses” on page 470.

Some other important things to consider:



- Rafters and joists that are parallel to a roof truss are not generated closer than 14 inches (350mm) to the truss.
- Automatically produced rafters and joists do not cross an existing truss, but do generate from the eave inward until they butt into a truss.
- Rafters and hip ridges can pass over a drop hip truss. See “Drop Hip or California Hip” on page 476.
- Lookouts can pass over a reduced gable truss.

- When rafters are parallel to trusses, the tops of the rafters are placed in line with the tops of the trusses. Since the depth of a rafter is normally greater than that of a truss's top chord, the lower rafter edge is below the top plate of the supporting wall, requiring a birdsmouth cut into the rafter. If the truss is raised to provide space for insulation, the rafter may not need to be cut at all. If the truss is raised too much, the rafter may not rest on the top plate at all.



Framing with Beams

Floor/Ceiling Beams  can be drawn in a plan either before or after automatic framing has been generated. If a beam is created before automatic framing, you can specify whether joists bear on the beam or hang on its sides.



To build joists that bear on a beam

1. Draw a **Floor/Ceiling Beam**  at the desired location in your plan.
2. Select the beam and click the **Open Object**  edit button. On the General tab of the **Beam Specification** dialog, confirm that:
 - The **Top Height** value is equal to the Ceiling Height of the room(s) over which the beam is placed.
 - **Bearing Beam** is checked.
3. Click OK, then select **Build> Framing>** **Build Framing**  and build the appropriate floor or ceiling framing. See “Floor Tabs” on page 443.

To build joists that butt against a beam



1. Draw a **Floor/Ceiling Beam**  at the desired location in your plan.
2. Select the beam and click the **Open Object**  edit button. On the General tab of the **Beam Specification** dialog:
 - Specify the desired Depth value and then lock it.
 - Specify the **Bottom Height** value so that it is equal to the Ceiling Height of

the room(s) over which the beam is placed.

- Uncheck **Bearing Beam**.
3. If necessary, select **Build> Framing> Joist Direction Line**  and draw a line perpendicular to the beam and within the floor or ceiling platform.
 4. Click OK, then select **Build> Framing> Build Framing**  and build the appropriate floor or ceiling framing. See “Floor Tabs” on page 443.

The Framing Tools

 Select **Build> Framing** to access the automatic and manual Framing Tools.

The Framing Tools family has three separate parent buttons: **General Framing Tools** , **Floor/Ceiling Framing Tools** , and **Roof Framing Tools** .

The default settings for framing members are derived from their respective tabs in the **Framing Defaults** dialog.

Most types of framing can be created both manually and automatically. Once created, both automatically generated and manually drawn framing members can be selected and edited. See “Editing Framing” on page 460.



As a general rule, horizontal framing members are referred to as "joists" (floor/ceiling platform framing); vertical framing members are referred to as "studs" (wall framing); and sloped framing members are referred to as rafters (roof framing).

Build Framing

 Select **Build> Framing> Build Framing** to open the **Build Framing** dialog. Here, you can define settings that control how framing is drawn and generate automatic framing. See “Build Framing Dialog” on page 443.

General Framing

 General Framing objects are generic, framing members that can be drawn outside of a floor or ceiling platform or roof plane. Select **Build> Framing> General Framing**, then click and drag in a straight line to create one of these objects. In floor plan view, a horizontal framing member is created.

Post

 Posts can only be placed manually. To do so, select **Build> Framing> Post** and click in floor plan view. Placing a post

on the lowest level of a plan also creates a footing.

Rafter



Rafters can be drawn both manually and automatically. To draw a rafter manually, select **Build> Framing> Rafter**, in floor plan view, then click and drag in a straight line within a roof plane.

Rafters are edited like other framing members, except that you cannot set the height. If a rafter is moved, its height and slope are automatically reset to fit under the roof plane at its new position.

Roof Blocking



Roof blocking can only be drawn manually. To do so, select **Build> Framing> Roof Blocking** in floor plan view and click and drag in a straight line within a roof plane.

Each run of blocking has gaps where it crosses rafters, trusses or other blocking but behaves as a single object.

Blocking is typically drawn perpendicular to the rafters, but at the same pitch. so blocking as seen in floor plan view represents the position of the top of the blocking.

Before drawing Roof Blocking:

- Specify whether you want **In Line**, **Stagger** blocking, or **Cross** bridging in the **Framing Defaults** dialog.
- Build the roof framing. See “Roof Tab” on page 451.

In 3D, roof blocking is tilted to follow the pitch of the roof plane in which it is drawn.

Roof Truss



Roof trusses can only be drawn manually. To do so, select **Build> Framing> Roof Truss** in floor plan view and click and drag in a straight line within one or more roof planes. Roof planes and either a default or manually drawn ceiling must be present before a roof truss can be drawn. See “Roof Trusses” on page 470.

Roof Beam



Roof beams can only be drawn manually. To do so, select **Build> Framing> Roof Beam** in floor plan view and click and drag in a straight line. Roof beams are normally be drawn across rafters and placed directly under them.

Joist



Floor and ceiling joists can be drawn both manually and automatically. To manually draw a joist, select **Build> Framing> Joist** in floor plan view, then click and drag in a straight line within a floor or ceiling platform.

Joists are always drawn as the ceiling framing for the current floor. See “The Current Floor” on page 326. Whether a floor or ceiling joist is drawn is determined by the presence of a floor platform above.

- If there is no floor platform above, a ceiling joist is drawn.
- If there is a floor platform above, a floor joist is drawn.

If you want to draw floor joists for Floor 1, for example, you must do so on Floor 0. See “Foundations” on page 329.

Joists can be automatically generated for multiple floors in the **Build Framing** dialog. See “Floor Tabs” on page 443.

 Ceiling joists, floor joists and rafters have their own layers. Proper layer assignment maximizes display and materials flexibility.

Joist Blocking

 Joist blocking can only be drawn manually. To do so, select **Build> Framing> Joist Blocking** in floor plan view and click and drag in a straight line within a floor or ceiling platform.

Each run of blocking behaves as a single object.

Before drawing Joist Blocking:

- Specify whether you want **In Line**, **Stagger** blocking, or **Cross** bridging in the **Framing Defaults** dialog.
- Build the floor and/or ceiling platform. See “Floor Tabs” on page 443.

Floor/Ceiling Truss

 Floor and ceiling trusses can only be drawn manually. To do so, select **Build> Framing> Floor/Ceiling Truss** in floor plan view and click and drag in a straight line within a floor or ceiling platform. See “Floor and Ceiling Trusses” on page 470.

Floor/Ceiling Beam

 Floor and ceiling beams can only be drawn manually. To draw one, select **Build> Framing> Floor/Ceiling Beam** in floor plan view and click and drag in a

straight line within a floor or ceiling platform.



Beams can be drawn in two different ways:

- **Under Joists** places the beam underneath the joists so the joists can bear on it.
- **With Joists** places the top of the beam even with the tops of the joists it supports. The joist then butts against it. See “Posts/Beams Tab” on page 449.

 Beams should be placed before joists are produced by automatic framing. If **With Joists** is specified, the joists are cut by and butted against the beam. If **Under Joists** is specified, the joists are automatically butted or lapped over the beam.

Framing Reference Marker

 **Framing Reference Markers** are reference points that specify how to lay out automatically-produced framing and can only be drawn manually. To place one, select **Build> Framing> Framing Reference Marker** in floor plan view and click to place a framing reference marker.

A **Framing Reference Marker**  can also be created by placing a **Marker**  and then specifying its type. See “Markers” on page 762 and “Framing Reference Markers” on page 454.

Bearing Line

 **Bearing Lines** direct the program to lap or butt joists and/or rafters where they cross the line instead of framing across it to the next wall and can only be drawn in floor plan view. To draw one, select **Build> Framing> Bearing Line** and click and drag

in a straight line. See “Bearing Lines” on page 456.

Joist Direction





Joist direction lines define the direction in which joists run in a floor

or ceiling platform and can only be drawn in floor plan view. To draw one, select **Build> Framing> Joist Direction** and click and drag within a floor or ceiling platform. See “Joist Direction Lines” on page 457.

Build Framing Dialog



Automatic framing can be generated by selecting **Build> Framing> Build Framing** to open the **Build Framing** dialog. This dialog can also be accessed by double-clicking either the **Framing Tools**  button or the **Rafter**  tool.

The **Build Framing** dialog is organized so that each major structural component of the model has its own tab or tabs. The number of tabs in the dialog varies depending on how many floors are in your model. There is a tab called “1st” for the first floor, “2nd” for the second floor, and so on.

- Floor and ceiling framing settings are found on the Floor Tabs.

- Wall framing settings are located on the Wall Tab, Openings Tab, and Headers Tab.
- Post, floor/ceiling beam and roof beam settings are found on the Posts/Beams Tab.
- Roof framing settings are located on the Roof Tab and Trusses Tab.
- The settings on the Roof tab are the same as those on the Framing tab of the Build Roof Dialog.
- You can set the default materials used for framing on the Materials Tab. See “Materials Tab” on page 454.

Floor Tabs

The **Build Framing** dialog opens to the framing tab for the current floor, such as **Foundation**, **1st** or **2nd**. Each tab specifies framing for specific floors or assemblies. Switch between tabs to define all settings.

The floor framing information for a given floor is found on the Floor tab for the floor below it, because that is where the framing will display in floor plan view when it is generated. For example, the floor framing information for Floor 2 is found on the **1st**

tab, while the floor framing for Floor 1 is found on the **Foundation** tab.

To automatically generate the floor framing for Floor 1, a Floor 0 must be present. If a Floor 0 has not been built, the **Build Floor Framing** check box on the Foundation tab will not be available.

Each Floor tab is divided into two halves:

- The right half is for floor framing specifications, and applies to the model when the floor above has living space.

- The left half is for ceiling framing specifications, and is relevant only for rooms that do not have living spaces above them. See “Floor and Ceiling Platforms” on page 321.

The platform structure settings defined here affect all rooms on the floor, but can be overridden for individual rooms in the **Room Specification** dialog or for individual

platforms using **Joist Direction**  lines. See “Structure Tab” on page 245.

By default, joists automatically generate in the direction that results in the shortest span; however, you can produce different results

using **Bearing Lines** , **Floor/Ceiling Beams**  and/or **Joist Direction**  lines. See “Bearing Lines” on page 456 and “Joist Direction Lines” on page 457.

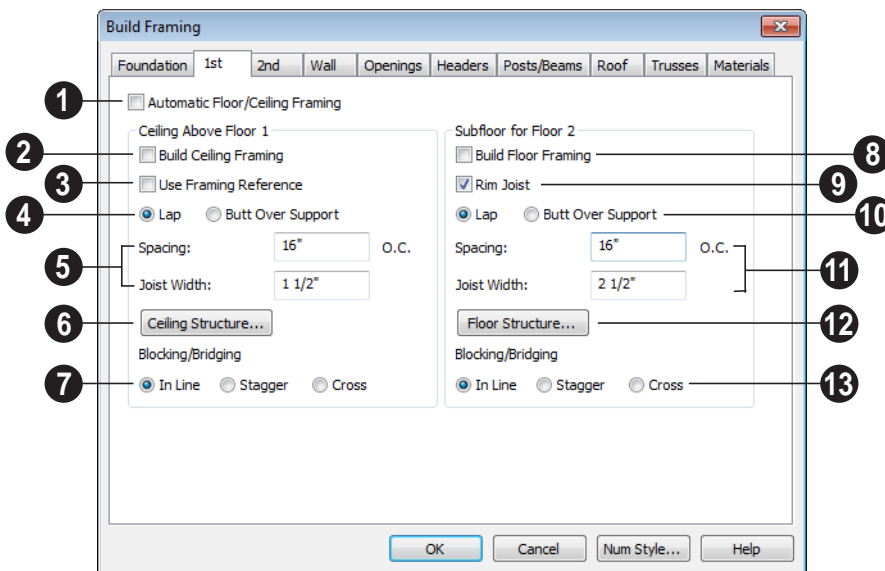

1 Check **Automatic Floor/Ceiling Framing** to regenerate floor and ceiling framing whenever changes are made to the model. See “Automatic Framing” on page 438.

2 Check **Build Ceiling Framing** to generate or regenerate ceiling framing when the **OK** button is clicked. Only available when there is no living space above at least part of the current floor.

3 **Use Framing Reference** - This applies to ceiling framing only. The Framing Reference Marker is the starting point for framing layout. If a reference is placed, the center of the first joist is placed at this point and spacing goes from there. If joists are lapped, the surface is placed at this point.

If the check box is cleared, the program attempts to position ceiling joists so that they coincide with rafters. Be sure to build the roof framing first if you are doing this.

A Framing Reference Marker is not usually used for both ceiling joists and nearby rafters that run the same way because one is placed on top of the other.

For floor joists, the starting point for a joist layout is always the Framing Reference Marker. See “Framing Reference Markers” on page 454.

- 4 Specify whether the ceiling framing members **Lap** or **Butt** over bearing walls. The lap is 8” (200 mm) and centered over the support.
 - When a Framing Reference Marker is used and **Butt Over Support** is selected, the joists are placed at reference spacing.
 - If **Lap** is selected, the surfaces where the joists lap are placed at reference spacing, so that joists are placed on either side of the framing reference locations.
- 5 Specify the spacing and size of the ceiling framing.
 - Enter a value for the **Spacing** of ceiling joists above the current floor.
 - Specify the **Joist Width**, which is their horizontal thickness.
- 6 Click the **Ceiling Structure** button to open the **Ceiling Structure Definition** dialog and define the layers of materials that form the ceiling platform. See “Floor/Ceiling Structure Definition Dialog” on page 323.
- 7 **Blocking / Bridging** specifies how blocking is manually drawn after joists have been placed. See “Joist Blocking” on page 442.
 - **In Line** produces blocking pieces that align with each other.

- **Stagger** produces blocking that alternates on either side of the line you draw.
- **Cross** produces cross bridging that looks like in line blocking in floor plan view, but shows as cross bridging in 3D views and the materials list.

- 8 Check **Build floor framing** to generate or regenerate floor framing when the **OK** button is clicked. Build Ceiling Framing is only available when there is no living space above at least part of the current floor.
- 9 Check **Rim Joist** to automatically produce a rim joist across the ends of the floor joists. If this is unchecked, line blocking across the ends of the floor joists is usually drawn in later.
- 10 Specify if the framing members **Lap** or **Butt** over bearing walls. See #4, above.
- 11 Specify the spacing and size of the floor framing.
 - Enter a value for the **Spacing** of floor joists above the current floor.
 - Specify the **Subfloor Thickness**, which is the thickness of the floor sheathing.
 - Specify the **Joist Width**, which is their horizontal thickness.
 - Specify the **Joist Depth**, which is their vertical depth.

The Subfloor Thickness and Joist Depth both affect floor platform thicknesses and can be overridden per room in the **Room Specification** dialog. See “Structure Tab” on page 245.

When viewing framing, **Subfloor Thickness** may be represented by a gap. To remove this gap, change the value to zero and rebuild the framing.

If the material Concrete is applied to the floor, platform thickness is specified in the **Foundation Defaults** dialog. See “Building a Foundation” on page 334.

12 Click the **Floor Structure** button to open the **Floor Structure Definition** dialog and define the layers of materials that

form the floor platform. Only available if there is living space above at least part of the current floor. See “Floor/Ceiling Structure Definition Dialog” on page 323.

13 Specify how **Blocking / Bridging** is manually drawn after joists have been placed. See “Joist Blocking” on page 442.

Wall Tab

The Wall, Openings, and Headers tabs are all referenced by the program to determine how walls are framed. The settings on these three tabs define how automatic framing generates and how wall framing is calculated for the Materials List.

 You can still make changes to your plan once you have framed your model. If your changes affect framing, if a wall or ceiling were moved for instance, rebuild framing to update the model.

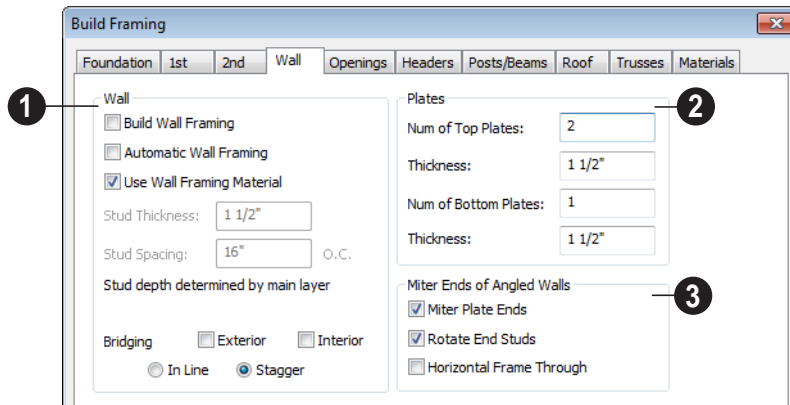

- 1** Specify how **Wall** studs and bridging are built.
- Check **Build Wall Framing** to build wall framing for the entire model. Framing is built in walls whose Main Layer material type is “framing”. See “Wall Type Definitions” on page 209.
 - Check **Automatic Wall Framing** to regenerate wall framing whenever

- changes are made to the model. See “Automatic Framing” on page 438.
- Check **Use Wall Framing Material** to use the stud thickness and spacing defined for the framing material used by each wall type. See “Define Material Dialog” on page 643. Uncheck this box to use the thickness and spacing values below for all wall types.

- Specify the **Stud Thickness** for all walls in the plan. Stud depth is set by each wall's Main Layer thickness. Not available when Use Wall Framing Material is used.
- Specify the **Stud Spacing** for all walls in the plan, starting from the Framing Reference Marker, if one is present. See “Framing Reference Markers” on page 454. Not available when Use Wall Framing Material is used.

Specify where and how **Bridging** is drawn. Each run of bridging behaves as a single object but has gaps where it crosses studs.

- Check **Exterior** to automatically produce bridging on external walls when wall framing is built.
- Check **Interior** to automatically produce bridging on internal walls when wall framing is built.
- **In Line** produces bridging pieces that align with each other.
- **Stagger** produces bridging that alternates on either side of a center line along the wall.

Wall bridging is generated exactly half-way up each wall's total height. Once created, it can be selected in a Framing Overview.

- 2 Define how top and bottom **Plates** are generated.
 - Specify the **Number of Top Plates**, as well as their **Thickness**.
 - Specify the **Number of Bottom Plates**, as well as their **Thickness**.
- 3 **Mitre Ends of Angle Walls** - Specify how wall corners that are not right

angles are framed. 90° corners are not affected by these settings.

- Select **Mitre Plate Ends** to mitre the ends of the top and bottom plates. If unchecked, top and bottom plates will be butted together.
- Select **Rotate End Studs** to rotate the studs closest to mitre ends to the angle of the mitre. If unchecked, studs will remain perpendicular to the angle of the walls.
- Select **Horizontal Frame Thru** to frame through the horizontal walls in floor plan view, butting vertical walls against them. If unchecked, walls that are vertical in floor plan view will frame through.

Openings Tab

The rough openings for doors and windows can be specified in the **Door** and **Window Defaults** dialogs. See “Default Settings” on page 56.

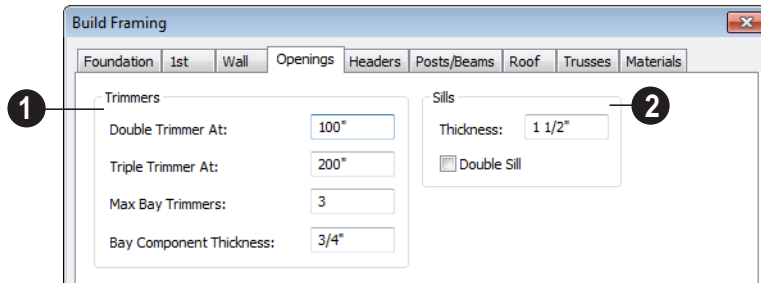

1 Specify when to build more than one **Trimmer**, which is a stud shortened to support a header, based on wall opening width.

- **Double Trimmer At** - Openings up to this value in width have two trimmers on each side.
- **Triple Trimmer At** - Openings up to this value in width have three trimmers.
- Specify the **Max Bay Trimmers**, which is the maximum number of trimmers that a bay, box or bow window with a lowered top height can have on each side of the opening. Enter 0 to suppress trimmers for bay/box/bow window opening headers.

- Specify the **Bay Component Thickness**, which is the thickness of a thinner trimmer for bay/box/bow window component headers if a standard trimmer does not fit after the component window is manually resized. See “Resizing Components” on page 291. The default for this value is 3/4” (20mm).

2 Specify the construction of the window **Sills**, which refer to the framing below the window rather than the finished sill.

- Specify the **Thickness** for window sills.
- Check **Double Sill** to specify a double sill for all windows.

Headers Tab



Home Designer Pro does not calculate loads or bearings. It is dependent upon user input and does not attempt any structural analysis. Always consult your local building authorities and contact a licensed engineer for structural calculations.

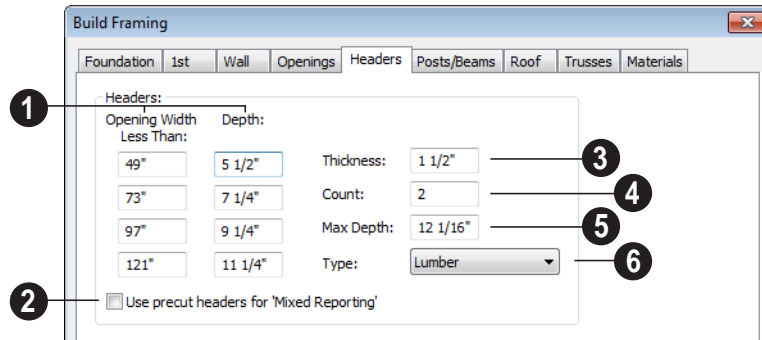

1 Specify the header depth dependent on the opening width. These values should be set so that the wider the opening, the deeper the header.

2 Check **Use precut headers for 'Mixed Reporting'** to show precut headers in the Materials List. Precut headers are shown only if the walls have been framed and Mixed Reported is selected as the reporting method. See "Structural Member Reporting" on page 898.

If this is unchecked, the Materials List produces a total footage for all headers. When checked, each different length of precut header is listed separately. Note that the total number of headers is twice the number of openings if **Count** is set to 2.

3 Specify the **Thickness** of all headers.

4 Specify the **Count** of boards required to make a header. Using this number, the program generates a count of header stock for you in the Materials List.

When using stock as thin as 1-1/2 inches, headers are usually doubled or laminated, so the default number of boards making up a header in **Count** is 2.

5 If the top of the rough opening is closer to the top plate than the value in **Max Depth**, a solid header is produced to fill the entire area. This disables the building of short cripple studs between the top of the header top and bottom of the plate. The default of 12 1/16 inch works well for 6'8" headers in 8'0" walls.



6 Specify the **Type** of material used for headers. See "Framing Member Types" on page 463.

Posts/Beams Tab

Posts and beams are not produced by the automatic framing. They can only be created manually.

Posts are created by clicking in floor plan view where a post is desired using the

Post  tool.

Beams are drawn manually in floor plan view using the **Floor/Ceiling Beam**  or **Roof Beam**  tool.

 Posts and beams may be created under a Deck room automatically, depending on its size, location, and other variables. Deck Framing defaults are set in the Deck Room Defaults dialog. See "Deck Framing and Planking" on page 239.

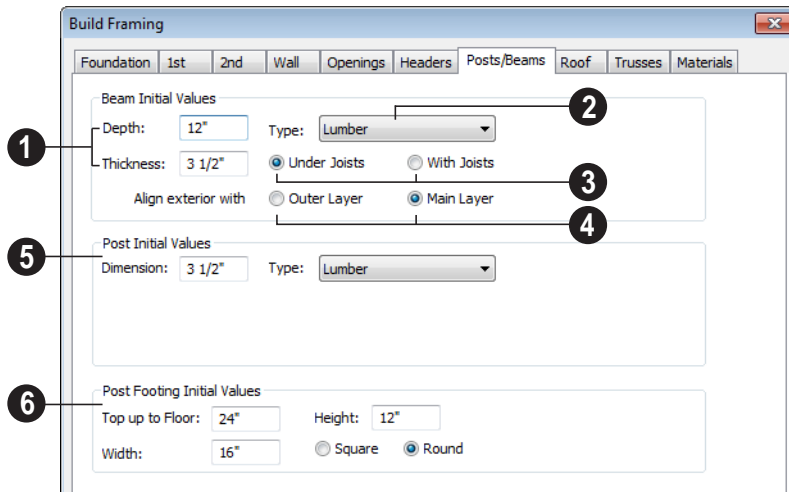

- 1 Specify the size of the beams in the plan. These settings do not affect automatically generated deck beams.
 - Specify the beams' vertical **Depth**.
 - Specify the beam **Thickness**, which appears as width in floor plan view.
- 2 Select the **Type** of beam from the drop-down list. See "Framing Member Types" on page 463.
- 3 **Under Joists/With Joists** - A beam can be drawn under the joists or up in the floor platform with the joists. If floor joist depths and subfloor thickness have been set in the **Build Framing** dialog, the beam height is properly positioned even if the joists have

not yet been produced. If **With Joists** is specified, the beams should be drawn before framing is automatically produced. Then the joists are broken and butted to the beam.

- 4 **Align Exterior with Outer Layer/Main Layer** - When a beam is drawn along and over an exterior wall, its outer surface snaps to either the wall's outer layer or outer main layer, as specified here.
- 5 **Post Initial Values** - Specify the initial characteristics of posts placed manually using the **Post**  tool. These settings do not affect automatically generated deck posts.
 - **Dimension** - This is the length of each side of a square post and the diameter of a

round post. Once created, posts not specified as Round can be edited to have a rectangular shape with any dimensions.

Round posts can be resized but always remain circular.

- Select the **Type** of post from the drop-down list. The Round Type is unique to Posts.

6 Post Footing Initial Values - When a post is placed on the lowest floor of a plan and inside a floor platform or generated under a deck, a footing for it is automatically

produced and included in the Materials List. See “Materials Lists” on page 887.

- Specify the **Top up to Floor** value, which is the distance from the top of the footing to the bottom of the floor platform.
- Specify the **Width** of the automatically produced footing under a new post.
- Specify the **Height** of the automatically produced footing under a new post.
- Select the **Square** or **Round** radio button to specify the shape of post footings.

Roof Tab

The settings on the Roof tab of the **Build Framing** dialog are exactly the same as those on the Framing tab of the **Build Roof** dialog. See “Build Roof Dialog” on page 355.

Note: Changes made on the Roof tab will not affect the structure of existing roof planes. To make changes take effect, rebuild the roof.

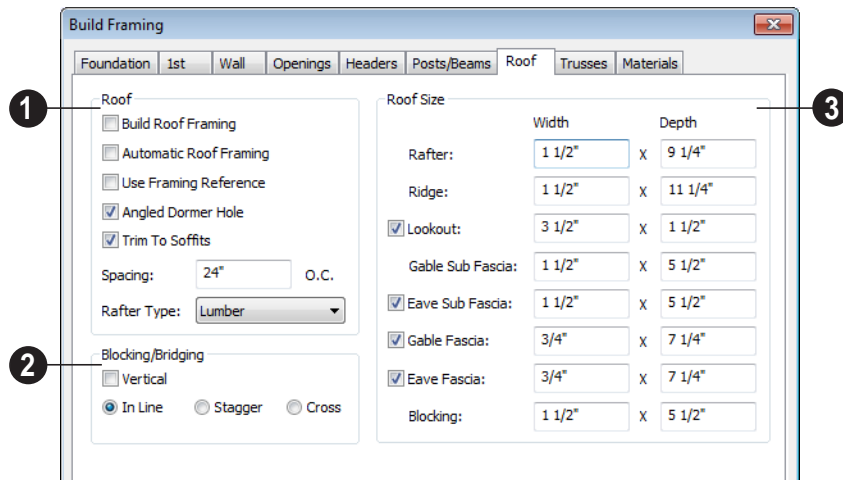

1 Roof -

- Check **Build Roof Framing** to build roof framing for the entire model. Only available if roof planes are present in the plan. See “Roofs” on page 349.
- Check **Automatic Roof Framing** to automatically rebuild roof framing if changes are made to the roof plan. See “Automatic Framing” on page 438.
- Check **Use Framing Reference** to use a defined starting point for rafter layout. See “Framing Reference Markers” on page 454.

Note: Use Framing Reference is useful when framing a gable roof, but not necessarily a hip roof. See “Framing References and Roof Framing” on page 455.

- Check **Angled Dormer Hole** to create a 5-sided hole in a roof plane to accommodate a gable dormer. The two top edges of the hole are located under the dormer valleys, and an angled double-header runs between the doubled rafters on one side to the ridge. A shorter angled doubled header frames the opposite valley.

If **Angled Dormer Hole** is unchecked, a rectangular hole is framed under the dormer. A double header is placed where the peak of the dormer roof meets the main roof plane, and rafters are placed under the dormer valleys.

If the double header does not fit within the main roof plane, angled headers are produced regardless of this setting.

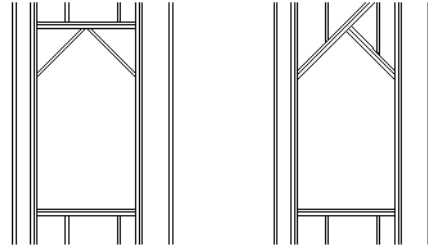

rectangular dormer hole

Angled Dormer Hole

- Uncheck **Generate Fascia** if you do not want fascia boards on the roof eaves. If unchecked, the Gable Fascia and Eave Fascia options under Roof Size will be unavailable.
 - Uncheck **Generate Eave Sub Fascia** if you do not want subfascia boards on the roof eaves. If unchecked, Eave Sub Fascia under Roof Size will be unavailable.
 - Uncheck **Trim To Soffits** to generate full-depth rafters all the way to the subfascia. If checked, rafter depths are trimmed to the top surface of the soffits in the eave area.
 - Specify the **Spacing** of automatically generated rafters.
 - Select the **Rafter Type** from the drop-down list. See “Framing Member Types” on page 463.
- 2** Specify how **Blocking/Bridging** is manually drawn after rafters have been placed. A row of blocking is drawn and can be moved and edited as a single object, but displays as separate pieces separated by the rafters. See “Roof Blocking” on page 441.
- Check **Vertical** to generate blocking that is oriented vertically, or plumb. When

unchecked, blocking is perpendicular to the roof framing.

- **In Line** produces blocking pieces that align with each other.
- **Stagger** produces blocking that alternates on either side of the line you draw.
- **Cross** produces cross bridging that looks like in line blocking in floor plan view, but shows as cross bridging in 3D views and the materials list.

3 Specify the desired **Width** and **Depth** for **Rafters**, the **Ridge**, **Lookouts**, **Gable Sub Fascia** (barge rafter), **Eave Sub Fascia**, **Gable Fascia**, **Eave Fascia** and **Blocking**.

Uncheck the boxes beside **Lookout**, **Eave Sub Fascia**, **Gable Fascia** and/or **Eave Fascia** to prevent these framing members from generating when roof framing is built. When these boxes are checked, these items will generate as specified here.

Trusses Tab

The parameters set in this tab apply to any subsequently drawn trusses. They can be overridden for any selected group of trusses using the **Truss Specification** dialog. See “Trusses” on page 469.

The program uses these values to model trusses for graphic representation only.

 Home Designer Pro does not engineer trusses. Always consult an engineer or truss company to have your trusses professionally designed.

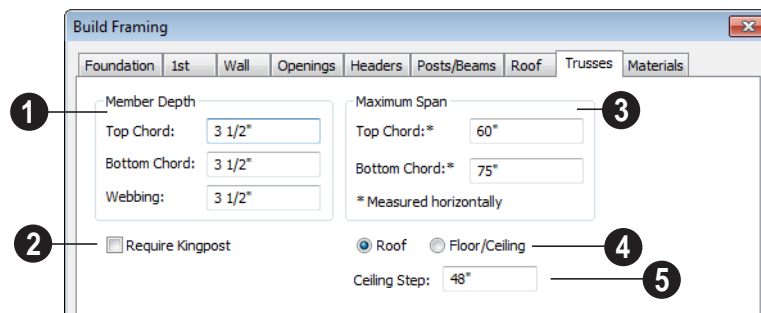

1 **Member Depth** - Specify the depth of the truss chords and webbing.

- Specify the depth of the **Top Chord**.
- Specify the depth of the **Bottom Chord**.
- Specify the depth of the **Webbing**

2 For triangular trusses, check **Require Kingpost** to require a vertical member from the roof peak to the bottom chord.

If this is not checked, a vertical member may still be supplied, depending on what is needed to support the chords at or closer than the specified maximum spans.

3 The **Maximum Span** settings control the maximum length between junctions of the supporting webbing to the **Top Chord** and **Bottom Chord**. Changing these values may cause different truss configurations such as kingpost, queenpost, fink, double fink, fan, howe, or double howe to be represented.

These distances are measured horizontally for both roof and floor and ceiling trusses. In some instances, especially in more complex trusses, making these spans equal may result

in the webbing appearing more normal or standard. See “Trusses” on page 469.

4 Select either **Roof** or **Floor/Ceiling** to specify whether the settings apply to Roof or Floor/Ceiling trusses.

5 Specify the **Ceiling Step**, which is the maximum distance its bottom chord can step down to locate a ceiling on the floor below the top floor. See “Ceiling Steps” on page 478.

Materials Tab

The default materials that display on General Framing objects, Posts, and Rafters in 3D views are specified on the Materials tab. These materials are not used in the Materials List. Materials List information is derived from the structure Type of each framing object. See “Framing and the Materials List” on page 462.

Changes made on the Materials tab of the **Build Framing** dialog only affect subsequently created framing: both manually drawn and automatically generated.

The settings in the Materials tab of the **Build Framing** dialog are the same as in many other specification dialogs. See “Materials Tab” on page 635.

Framing Reference Markers



Framing Reference Markers are reference points that specify how to lay out automatically-produced framing.

- Wall and floor framing always build to the Framing Reference Marker.
- Ceiling and roof framing only build to the Framing Reference Marker when **Use Framing Reference** is specified for that type of framing.

Typically, a single framing reference marker on Floor 1 is used for the entire model.

- When more than one marker is present, framing layout starts at the marker closest to the center of the area to be framed.

- If no framing reference marker is found on the floor being framed, the closest framing reference marker on the first floor is used.



If no framing reference markers exist in your plan, the point at 0, 0 is used as the framing reference marker location and unexpected results may occur.

When **Automatic Wall Framing** is checked, wall framing automatically rebuilds if a Framing Reference Marker is added or moved. See “Automatic Framing” on page 438.

Automatic Floor/Ceiling Framing and **Automatic Roof Framing**, on the other hand, do not respond when a Framing Reference Marker is added or moved. These framing types must be rebuilt using the **Build Framing** dialog. See “Build Framing Dialog” on page 443.

Placing Framing Reference Markers

To place a Framing Reference Marker, select **Build> Framing> Framing Reference**

Marker . Click in floor plan view to place the framing reference marker.

When **Object Snaps**  are enabled, framing reference markers snap to framing members and other CAD-based objects first, and then to a wall main layer surface or corner if possible.

Framing Reference Markers  can be modified just like other markers. See “Markers” on page 762.

When framing is generated using a Framing Reference Marker, the first framing member of a given type snaps to this point and all other framing members are laid out from there.

- Wall and roof framing snap to the Framing Reference Marker at their centers.
- Floor and ceiling framing snap to the Framing Reference Marker along an edge.

Move to Framing Reference

 Manually drawn framing and automatic framing that was not generated using a Framing Reference Marker can be moved relative to a Framing

Reference Marker using the **Move to Framing Ref** edit button.

When a framing member using the **Move to Framing Ref**  edit button, the on-center spacing distance set in the **Build Framing** dialog is used.

The **Move to Framing Ref**  edit button may also reference spacing specific to a particular floor or ceiling platform. See “Joist Direction Lines” on page 457.

A group of selected framing objects that are all parallel to each other can be moved using the **Move to Framing Ref**  edit button. Only one of the objects in the group is compared to the framing reference marker and moved; the remaining objects are simply moved the same amount as the first object. Ideally, therefore, the group should have proper spacing relative to each other before the move.

To move framing objects to a framing reference marker

1. Group select the framing objects.
2. Click the **Move to Framing Ref**  edit button.
3. The framing members are moved to the nearest Framing Reference Marker.

Framing References and Roof Framing

Framing Reference Markers are useful when framing a gable roof, but not necessarily a hip roof. When a Framing Reference is used, common rafters on either side of a hip rafter do not meet in the same place.

If the Framing Reference is not used, the automatic framing utility starts common rafter spacing from each end of the

horizontal ridges, which results in common rafters on either side of hip jacks meeting each other.

Bearing Lines



Bearing Lines direct the program to lap or butt joists and/or rafters where they cross the line instead of framing across it to the next wall.

Select **Build > Framing > Bearing Line** , then click and drag to draw a bearing line as you would draw a CAD line. Bearing lines are edited just like CAD lines or polylines, as well. See “Editing Line Based Objects” on page 127 or “Editing Open Polyline Based Objects” on page 134.

If a bearing line exists, the program laps or butts the joist and/or rafters over the line, depending on the option selected in the **Build Framing** dialog. See “Floor Tabs” on page 443.

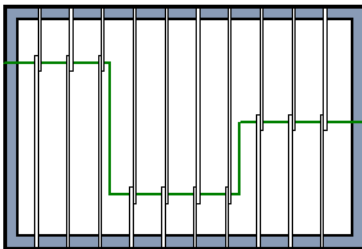

Joists lapping over a Bearing Line

A bearing line should start outside the floor or ceiling platform and end outside of it, passing completely through the building.

Bearing lines snap to the center of nearby parallel walls when framing is built.

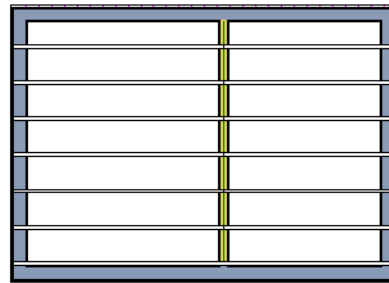

Joists butting over a Bearing Line and interior wall

A platform can be split into two by a bearing line, and the joist direction and/or depth can be specified separately on each side of the bearing line. Each platform takes on properties given by the joist direction line it contains. See “Joist Direction Lines” on page 457.

Placing a **Floor/Ceiling Beam**  in a plan can also have the same effect as a Bearing Line when **Bearing Beam** is checked in its **Beam Specification** dialog. See “Framing Specification Dialog” on page 463.

Joist Direction Lines



A **Joist Direction** line defines the direction in which joists run in the floor or ceiling platform in which it is drawn, as well as the joists' depth and spacing.

If a direction line is not specified, joists run in the direction that results in the shortest span and use the depth and spacing set in the **Framing Defaults** dialog.. See “Floor and Ceiling Framing” on page 436.

Using Joist Direction Lines

Select **Build> Framing> Joist**

Direction  and draw a joist direction line just as you would draw a CAD line. In order to work, Joist Direction Lines must be drawn within the area of a floor or ceiling platform.

The text along the joist direction line states the joist size and spacing for the platform. Initially, these values reflect the settings in the **Framing Defaults** dialog. See “Floor Tabs” on page 443.

Joist Direction Lines are located on the “Framing, Bearing Lines” layer and use the Text Style assigned to the layer that the Joist Direction Line is on. See “Text Styles” on page 765.

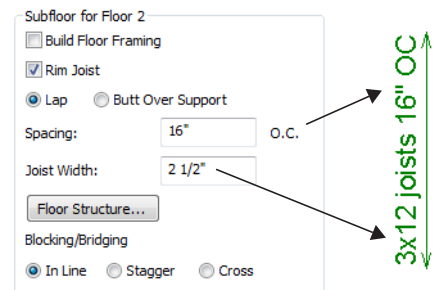

Each floor in a plan can have more than one floor platform, and each floor platform can have its own joist direction.

Two **Joist Direction** lines, one on either side of a **Bearing Line**, can divide a single floor or ceiling platform into two, allowing you to define different framing specifications for each area.

Joist Direction Specification Dialog



A Joist Direction line controls the joist depth and spacing information for the floor or ceiling platform in which it is drawn. To change this information, select a joist direction line and click the **Open Object** edit button. The **Joist Direction Specification** dialog opens.

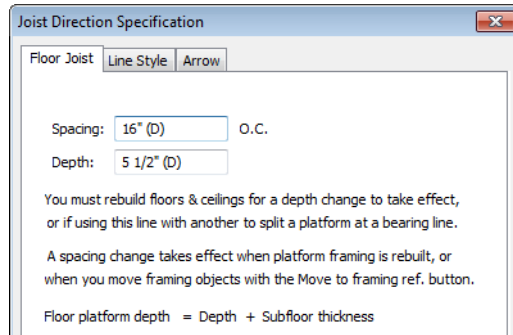

- Define the **Spacing** of the joists in this platform.
- Define the **Depth** of these joists.

Note: This is not the recommended method for specifying joist depth. You should instead use the settings in the Room Specification dialog. See “Room Specification Dialog” on page 244.

The Joist Direction line affects the joists in the entire platform, but does not change the settings in the **Build Framing** or **Room Specification** dialogs. Settings in the **Joist**

Direction Specification dialog affect subsequently produced framing only in the platform that contains the selected joist direction.

Line Style Tab

For information about the settings on this tab, see “Line Style Tab” on page 781.

Arrow Tab

For information about the settings on this tab, see “Arrow Tab” on page 783.

Displaying Framing



The display of framing members is controlled in the **Layer Display Options** dialog. See “Displaying Objects” on page 102.

In Floor Plan View

Joists, rafters and trusses are represented in floor plan view by line-based CAD objects that are essentially long, thin rectangles. See “Editing Line Based Objects” on page 127.

If you prefer, framing and trusses can instead be represented by a single line. See “Line Properties Panel” on page 75.

By default, framing polylines have a solid white fill, and new members display in front of older ones, helping to distinguish newer members from those drawn previously. You can specify whether new framing members are drawn with this fill. See “CAD Defaults and Preferences” on page 770.

In 3D Views

The easiest way to view framing in 3D is to use either the **Orthographic Framing**

Overview  or **Perspective Framing**

Overview  tool, which display the model using the 3D Framing Set layer set. See “Framing Overview” on page 675.

Framing objects can display in other 3D and cross section/elevation views, although by default they are not set to do so. If you wish to see framing in these views, turn on the framing layers when the view is active.

To reveal framing covered by other objects or wall layers, use the **Delete Surface**  tool. See “Delete 3D Surface” on page 679.

In Cross Section/ Elevation Views

To display framing in a cross section/elevation view, make sure the framing layers are turned on in the **Layer Display Options** dialog. See “Layer Display Options Dialog” on page 104.

You can also use the **Delete Surface**  tool to temporarily delete the surfaces of wall layers or other objects that block the view.

In cross section/elevation views, framing objects that are cut by the cross section plane display as boxes containing an 'X'.

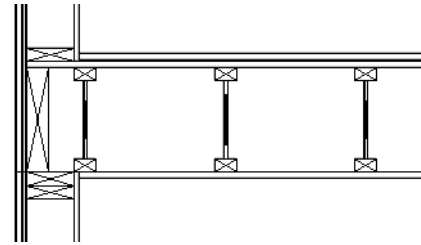

I-joists, a rim joist, and wall plates cut in a cross section view

Framing Materials and Types

The appearance of a framing member in 3D and cross section/elevation views is affected by the material assigned to it and also by its Type.

The material specified for a framing member determines what it looks like in camera views by applying a texture, pattern, or color to its surface. Materials have no effect on how the framing is calculated in the Materials List, however.

The default materials for framing are set:

- In the **Floor and Ceiling Structure Definition** dialogs for floor and ceiling framing. See “Floor and Ceiling Platform Definitions” on page 322.
- In the **Wall Type Definitions** dialog for wall framing. See “Wall Type Definitions Dialog” on page 211.
- In the **Framing Defaults** dialog for General Framing, Posts, and Rafters. See “Materials Tab” on page 454.

Framing Types can also influence how a framing member looks in camera views because some types have special profiles - for example, I-Joists, Steel-I, and C-Channel. Framing types are also stated in the

Description column in the Materials List. See “Framing Member Types” on page 463.



Materials and framing types control how framing looks in 3D views

In the Materials List

When framing is calculated in the materials list, its dimensions and type are noted.

Treated lumber is also counted separately from regular lumber. See “Framing Member Types” on page 463.

Framing lengths can be counted using one of several methods to produce, for example, cut lists and buy lists. See “Structural Member Reporting” on page 898.

If framing is not present in a plan when a Materials List is created, it will not be calculated. See “Framing and the Materials List” on page 462.

Editing Framing

Framing members can be individually selected in all views. Some framing members can be group selected. Once selected, framing members can be edited using the edit handles, edit toolbar buttons, or the **Framing Specification** dialog. See “Framing Specification Dialog” on page 463.

When **Start and End Indicators** are enabled in the **Preferences** dialog, a selected framing member will display an S and an E at its start and end points. This makes it easier to choose which end to lock when specifying its Length or Angle. See “Edit Panel” on page 76.

Framing is organized into families which determine where it is generated and where it can be manually drawn. See “Manual vs. Automatic Framing” on page 437. Once framing has been created, however, it can be moved out of its structural component. In order to move roof framing above or below a roof plane, you must first check **Manual**

Rafter Height in the **Framing Specification** dialog. See “General Tab” on page 464.

Using the Edit Handles

Framing members can be drawn, edited and moved much the way CAD lines can. See “Editing Line Based Objects” on page 127.

In Cross Section/Elevation views, joists and rafters cut by the cross section and displaying a cross box can also be edited. See “Editing Box-Based Objects” on page 141. Also, in Cross Section/Elevation views headers can be edited like closed polylines. See “Editing Closed-Polyline Based Objects” on page 138.

In a camera view or overview, the handles that display on a framing member depend on where it is clicked for selection and your current zoom factor.

- Click the top surface to display the same edit handles as in floor plan view, allow-

ing you to rotate, move, and extend or shorten the length of the member.

- Click a side surface to display the same edit handles as in an elevation view, one at each end and one at the center.
- Zoom in and click on the appropriate edge to display edit handles that control the width and depth of framing members.

Using Dimensions



Framing members can be both moved and resized using dimensions. See “Moving Objects Using Dimensions” on page 737.

Using the Edit Tools

A selected framing member can be edited in a variety of ways using the buttons on the edit toolbar. See “The Edit Toolbar” on page 29.

Mitered Joints

Mitered joints can be created using the **Fillet**

Two Lines  edit button. Click on the end edge of a framing member such as a joist, click the **Fillet Two Lines**  edit button, then click on the end edge of another nearby joist to extend one framing item to another framing item and join them with angled cut. See “Fillet Two Lines” on page 159.

Steel and Concrete

You can set framing defaults to generate steel framing and concrete structural members as well as lumber and other framing types. Individual framing members can also be specified as concrete or steel, as well.

When setting up defaults or modifying an individual object, make sure you specify both the desired framing Type and the material. See “Framing Materials and Types” on page 459.

Roof and Floor Trusses

Roof and floor trusses cannot be edited like regular framing members can and are discussed in their own chapter. See “Editing Truss Envelopes” on page 474.

Deleting Framing

Individual and group-selected framing members can be deleted the way other objects in the program are. See “Deleting Objects” on page 171.

Categories of framing, such as wall framing or floor and ceiling framing, can also be deleted in the **Delete Objects** dialog. See “Delete Objects Dialog” on page 171.

Keeping Framing Current

When you modify your plan, move walls, raise or lower platforms or redesign the roof, any framing present in the plan will not update to reflect your changes. In order for the framing to be updated, you must

regenerate automatically produced framing and either edit or delete and replace manual framing.

For this reason, it is recommended that you wait until your model is finished, or nearly

finished, before creating framing. See “Drawing a Plan” on page 33.

Automatic Framing

Automatically-generated framing can be rebuilt using either of two checkboxes in the **Build Framing** dialog:

- Select a **Build** checkbox to build automatic framing once. For example, check **Build Wall Framing** on the Wall tab to build wall framing once based on the current state of the model. If the model is changed later, you may need to do this again.
- Select an **Automatic** checkbox to build automatic framing every time a change is made to that structural component in the plan. For example, check **Automatic Wall Framing** on the Wall tab to rebuild

all wall framing any time a wall is affected by changes to the model.

When floor, ceiling or roof framing is regenerated, all automatically produced framing objects and any copies of them are deleted and new framing is calculated. See “Rebuilding Framing” on page 438.

Manual Framing

It is vital to remember that manually drawn framing objects and copies of them are not retained when automatic framing is rebuilt.

If a plan is not final, therefore, do not spend a lot of time altering or copying automatically produced framing objects. It is best to wait until your design is final before doing manual framing work.

Framing and the Materials List

Each framing member created in a plan is counted in the Materials List. See “Materials Lists” on page 887.

Framing can be calculated using one of several reporting methods. See “Structural Member Reporting” on page 898.

Depending on what a framing member is used for, it may be listed in the Framing (F), Subfloor (SF), or Roofing (R) category. See “Categories” on page 890.

- Framing includes all wall framing, posts, and General Framing objects.
- Sub Floor lists floor and ceiling framing joists as well as sheathing.
- Roofing includes trusses, rafters, and sheathing.

It is important to note that the floor, ceiling, and roof framing counted in the Materials List may vary considerably depending on whether framing of those types is actually present in the plan:

- If no framing is present in the model, then the required floor, ceiling, and roof framing is estimated. Total lineal footage for various depths of rafters and joists is estimated, rather than a quantity of specific lumber lengths and sizes. Wall framing is not estimated.
- If even one floor, ceiling, or roof framing object exists in the plan, then objects in that category are counted instead of estimated for the Materials List.

Framing Member Types

A variety of framing member types is available for use in Home Designer Pro: Lumber, I-Joist, Glulam, Engineered Lumber, LVL, Steel I, Steel Box, Solid Concrete, C Channel, and U Channel. In addition, Round is an available Type for posts.

You can select any of these types as the default for floor and ceiling framing, headers, posts and beams, and roof framing. See “Build Framing Dialog” on page 443.

You can also specify the type for individual framing members in their specification dialog. See “General Tab” on page 464.

Changing the framing member type does not affect how framing is placed, but it may change its profile in cross section and 3D views and will affect its description in the Materials List.

The framing member type does not affect the appearance of the material used by a framing member in 3D views. See “Framing Materials and Types” on page 459.

Structural Member Reporting

You can specify whether framing materials are calculated by lineal foot, as a cut list, or as a buy list. See “Structural Member Reporting” on page 898.

Framing Materials and the Materials Tab

The materials applied to framing objects in 3D views are not used in the Materials List. Materials List information is derived from the structural use of each framing object and its **Type** - not the material seen on its surfaces in 3D views. See “Materials Tab” on page 454.

Framing Specification Dialog



Select a floor or ceiling joist, wall stud or rafter and click the **Open Object** edit button to open the **Framing Specification** dialog for the framing member type selected.

The options available in this dialog may vary depending on the type of object selected.

The settings in this dialog are similar to those in the **Beam Specification** dialog. See “Framing with Beams” on page 439.

General Tab

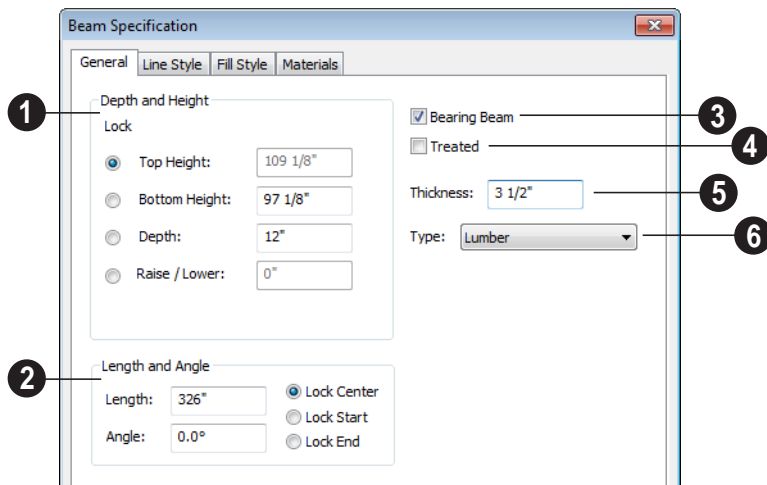

1 Depth and Height - Click the radio button beside one of the height values to lock it, then change a value that remains available. Changing the Top Height, Bottom Height or Depth may change the other two values.

- Specify the **Top Height** of the post, as measured from the first floor subfloor at 0". For a rafter, this is the top height at its low end.
- Specify the **Bottom Height** of the post, as measured from the first floor subfloor at 0". For a rafter, this is the bottom height at its low end.
- Specify the **Depth** of the framing object. For a rafter, this is the depth measured perpendicular to the roof plane.
- Click the radio button beside **Raise/Lower** to enable it, then enter a value to raise or lower the framing object from its current position. Once a value is entered, the other controls are disabled. The amount is added to both the top height

and the bottom height when you click **OK**, and does not affect the depth.

- **Manual Rafter Height** - Normally, the height of each Rafter or Roof Beam end is reset after any move or edit so that it is located just under the roof surface. Check this box to allow the height of the object to be changed. Only available for Rafters and Roof Beams.

2 Length and Angle - Lock the point about which you want like the selected object to resize and/or rotate, then specify its exact length and angle. See "Editing Framing" on page 460.

- **Length** of the framing object. Rafter length is measured along the top of the rafter, and so is greater than the length measured in floor plan view.
- **Angle** of the framing object in floor plan view. Changing this rotates the object about the location specified by the radio buttons described below.

- Select **Lock Center** to resize or rotate the object about its center point.
 - Select **Lock Start** to resize or rotate the object about the location from which you started drawing the framing object.
 - Select **Lock End** to resize or rotate the object about the location where you stopped drawing it.
- 3 Check **Bearing Beam** to specify the selected Floor/Ceiling Beam as a load-bearing beam. When checked, automatically generated joists run perpendicular to the selected beam and either lap or butt over it, as specified in the **Build Framing** dialog. See “Floor Tabs” on page 443. Only available for Floor/Ceiling Beams.
 - 4 Check **Treated** to specify that the selected framing member be counted as treated in the Materials List.
 - 5 Set the framing member’s **Thickness**, which appears as its width in floor plan view.
 - 6 Select a **Type** of structural member from the drop-down list. See “Framing Member Types” on page 463.

Note: Instead of counting individual concrete posts and beams in the Materials List, the total volume of their concrete is calculated. The square footage for beam and post forms is also listed.

Line Style Tab

For information about the settings on this tab, see “Line Style Tab” on page 781.

Fill Style Tab

The settings on the Fill Style tab affect the selected object’s appearance in floor plan view. For information about these settings, see “Fill Style Tab” on page 792.

Materials Tab

The default materials on this tab are set in the **Build Framing** dialog. If you change the selected object’s framing Type, the material here may update - unless you have specified a non-default material. For information about the settings on this tab, see “Materials Tab” on page 635.

Post Specification Dialog



Select a post and click the **Open Object** edit button to open the **Post Specification** dialog.

General Tab

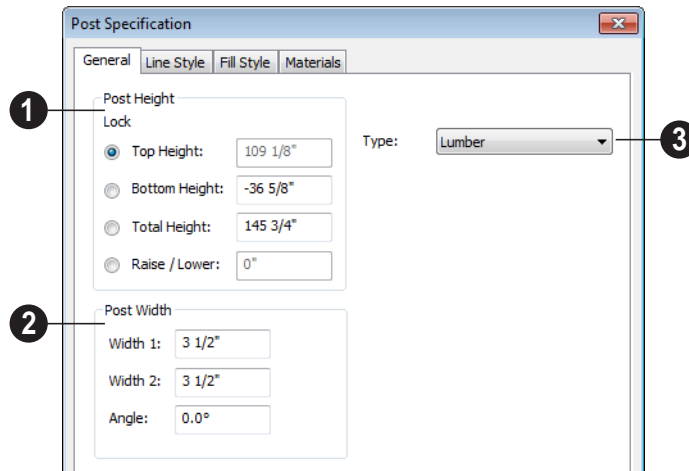

1 Post Height - Click the radio button beside a height value to lock it, then change an unlocked value. Changing the Top Height, Bottom Height or Total Height may change to the other values.

- Specify the **Top Height** of the post, as measured from the first floor subfloor at 0' 0".
- Specify the **Bottom Height** of the post, as measured from the first floor subfloor.
- Specify the **Total Height** of the post, which is the difference between the Top and Bottom Heights.
- Click the radio button beside **Raise/Lower** to enable it, then enter a value to raise or lower the post from its current position. When Raise/Lower is selected, the other controls are disabled. The amount is added to both the top height and the bottom height when you click **OK**, and does not affect the total height.

2 Post Width 1 & 2 - Specify the post width in each dimension.

- Specify the **Angle** of the post's rotation.

3 Select a **Type** from the drop-down list. The Round Type is unique to Posts. See "Framing Member Types" on page 463.

Note: Instead of counting individual concrete posts and beams in the Materials List, the total volume of their concrete is calculated. The square footage for beam and post forms is also listed.

Line Style Tab

For information about the settings on this tab, see "Line Style Tab" on page 781.

Fill Style Tab

The settings on the Fill Style tab affect the selected object's appearance in floor plan view. For information about these settings, see "Fill Style Tab" on page 792.

Materials Tab

The default materials on this tab are set in the **Build Framing** dialog. If you change the selected object's framing Type, the material

here may update - unless you have specified a non-default material. For information about the settings on this tab, see "Materials Tab" on page 635.

Trusses

There are two basic ways to frame a roof. The first is commonly called “stick framing,” or sometimes “handstacking” or “cut-and-stack.” This type of roof incorporates framing such as rafters, ridges, and ceiling joists. See “Framing” on page 435.

The other method is to use prefabricated, engineered roof trusses. Home Designer Pro allows you to design and display a wide variety of trusses.

Disclaimer

Home Designer Pro does not engineer trusses. The trusses displayed by Home Designer Pro are for illustrative purposes only. They can show how trusses are used in your plan, and help you communicate to the licensed engineer who produces your final truss design where you want your trusses and how you would like them to work.



Always have your truss designs approved by a licensed engineer.



Chapter Contents

- Truss Defaults
- Floor and Ceiling Trusses
- Roof Trusses
- Drawing Trusses
- Displaying Trusses
- Editing Trusses
- Editing Truss Envelopes
- Truss Labels
- Mixing Trusses with Stick Framing
- Hip Trusses
- Special Roof Trusses
- Roof Truss Specification Dialog
- Floor/Ceiling Truss Specification Dialog

Truss Defaults



The default settings for floor, ceiling and roof trusses are set in the **Framing Defaults** dialog. Select **Edit> Default Settings** and in the **Default Settings** dialog, select Framing and click the **Edit** button.

- The default settings for truss chord and webbing depth, maximum span, and king-post are set in the **Framing Defaults** dialog. See “Trusses Tab” on page 453.
- The overall depth of individual **Floor/Ceiling Trusses**  are based on the thicknesses of the platforms in which they are drawn. See “Floor Tabs” on page 443.
- The structure of **Roof Trusses**  is determined by the position of the roof plane(s) above and the ceiling plane(s) below. See “Roof Planes” on page 362 and “Ceiling Planes” on page 379.

Floor and Ceiling Trusses



Floor and ceiling trusses can be used instead of joists to frame platforms. As with manually-drawn floor and ceiling framing, the presence of a room above determines whether a floor or ceiling truss is drawn. For example, a truss drawn on the first floor of a single story home will be a ceiling truss, while a truss drawn on the first floor of a two-story building will be a floor truss for the 2nd floor.

Floor and ceiling trusses can only be drawn manually. To place a floor or ceiling truss in

your plan, select **Build> Framing> Floor/Ceiling Truss** , then click and drag within a floor or ceiling platform in floor plan view. See “Drawing Trusses” on page 471.

The Trusses tab of the **Build Framing** dialog contains default settings for floor and ceiling trusses. See “Trusses Tab” on page 453. These default settings can be overridden by the settings in the **Floor/Ceiling Truss Specification** dialog. See “Floor/Ceiling Truss Specification Dialog” on page 482.

Roof Trusses



Roof trusses can be used instead of or in combination with rafters to frame roofs and ceilings.

Roof trusses can only be drawn manually, and can only be created where roof and ceiling planes already are present. Select **Build> Framing> Roof Truss** , then click and drag in floor plan view within one

or more roof planes to manually draw a roof truss. See “Drawing Trusses” on page 471.

If you intend to use roof trusses, you need first to build your roof planes with this in mind. Before building the roof, select the **Trusses (no Birdsmouth)** check box in the **Build Roof** dialog. When this is checked, roof plane thickness is based on the default

Top Chord Depth set in the **Framing Defaults** dialog. See “Trusses Tab” on page 453.

If **Trusses (no Birdsmouth)** is not checked, the roof plane thickness is determined by the rafter **Depth** setting on the Roof tab of the **Framing Defaults** dialog.

Roof Truss Placement

A roof truss can only exist in the space defined by the roof planes above it and the ceiling planes below it. This is because the shape of a truss is defined by the location of the roof and the ceiling.

If **Ceiling Over This Room** is unchecked in the **Room Specification** dialog, you must manually draw a **Ceiling Plane**  before a roof truss can be drawn over that room. See “Structure Tab” on page 245.

If the program either does not find both roof and ceiling planes, or if there is not enough room between them, to model a truss, a warning message displays. For example, if you draw a truss in a roof overhang where there is no ceiling, this message displays:

“Roof and ceiling surfaces too close together or cannot be found, so cannot make truss.”

The incorrect truss may still display in floor plan view with a label of the form “TR-*”. If it does, it should be deleted or moved. See “Editing Trusses” on page 473.

One or both ends of a truss may be truncated if they are drawn across another truss. If this happens, it will end exactly on the surface of the existing truss, producing a girder truss. See “Girder Trusses” on page 478.

Trusses can end on interior walls. You can draw a truss that partially crosses the building by starting and/or ending it within 24” (600mm) of an interior wall. The truss extends over the wall’s Main Layer. Its end lines up with the Main Layer surface on the far side of the wall.

Roof Truss Webbing



The webbing in a newly drawn truss is controlled by the **Top Chord** and **Bottom Chord** settings in the **Framing Defaults** dialog. See “Trusses Tab” on page 453.

Changing these default values may cause different truss configurations such as kingpost, queenpost, fink, double fink, fan, howe, or double howe to be represented.

Drawing Trusses

Trusses cannot be generated automatically: they must be manually drawn and then replicated. All trusses are drawn similar to the way CAD lines are and can be drawn in floor plan view only. See “Draw Line” on page 776.

To draw and replicate trusses

1. Select either the **Floor/Ceiling Truss**  or **Roof Truss**  tool, then click and drag within either a floor/ceiling platform or one or more roof planes.

- Roof trusses seek an exterior wall and adjust their length automatically.
 - Floor/Ceiling trusses will snap to the wall surfaces, the exterior surface of a wall's Main Layer, as well as to a variety of CAD-based objects, and can be drawn to any length.
2. Reposition the truss:
 - Floor/ceiling trusses are often positioned relative to an exterior wall or **Framing Reference Marker** . See "Framing Reference Markers" on page 454.
 - Roof trusses are can be positioned over a gable end wall or at the ridge end of a hip.
 3. Open the truss's specification dialog and edit its settings to meet your needs. See

"Roof Truss Specification Dialog" on page 479 or "Floor/Ceiling Truss Specification Dialog" on page 482.

4. Make multiple copies of the truss at specified intervals using the Transform/Replicate Object  edit tool. See "Transform/Replicate Object Dialog" on page 166.

The copies of Roof Trusses automatically conform to the structural conditions in their new locations. As a result, replicated Roof Trusses and their labels may be different from the original. See "Truss Labels" on page 474.

Unlike Roof Trusses, Floor/Ceiling Trusses do not conform to new structural conditions when they are either moved or copied. See "Moving Trusses" on page 473.

Displaying Trusses



The display of trusses and their labels is controlled in the **Layer Display Options** dialog. See "Layer Display Options Dialog" on page 104.

Truss labels display in floor plan view and are used in the Materials List. See "Truss Labels" on page 474.

In 3D Views

The easiest way to view trusses in 3D is to use either the **Orthographic Framing**

Overview  or **Perspective Framing**

Overview  tool, which display the model using the 3D Framing Set layer set. See "Framing Overview" on page 675.

Trusses can display in other 3D and cross section/elevation views, although by default they are not set to do so. If you wish to see trusses in these views, turn on the "Framing, Trusses" layer when the view is active.

You can create exposed trusses by placing roof and ceiling planes to produce the desired truss structure, drawing the trusses, and then removing the ceiling. See "Vaulted and Cathedral Ceilings" on page 242.

To reveal trusses covered by other objects, you can use the **Delete Surface**  tool. See "Delete 3D Surface" on page 679.

In the Materials List

All trusses are listed under the Roofing category in the Materials List. Their labels

appear in the Size column, along with their length. See “The Materials List Tools” on page 888.

Editing Trusses

Trusses can be selected like other objects in Home Designer Pro. See “Selecting Objects” on page 124 for more information.

Once selected, trusses can be edited using dimensions, their edit handles, the edit toolbar buttons, or by opening them for specification.

When **Start and End Indicators** are enabled in the **Preferences** dialog, a truss selected in floor plan view will display an S and an E at its start and end points. See “Edit Panel” on page 76.

Trusses can be deleted all at once in the **Delete Objects** dialog. See “Delete Objects Dialog” on page 171.

Using Dimensions

Trusses can be relocated precisely using dimensions. See “Moving Objects Using Dimensions” on page 737.

Using the Edit Handles

When selected in floor plan view, trusses edit like CAD lines. See “Editing Line Based Objects” on page 127.

The depth of truss chords can be changed in the truss’s specification dialog, but not using the edit handles.

When selected in Cross Section/Elevation views and 3D views, trusses edit like closed

polylines. See “Editing Closed-Polyline Based Objects” on page 138.

Like joists or rafters, trusses can be selected and moved in 3D views. The only difference is that the **Lock Truss and Webbing** setting in the **Roof Truss Specification** dialog prevents the truss from moving back to between the roof and ceiling planes the next time it is edited or otherwise changed.

Using the Edit Tools

A selected truss can be edited in a variety of ways using the buttons on the edit toolbar. See “The Edit Toolbar” on page 29.

Moving Trusses

Trusses can be moved using either their Move edit handle or the **Transform/**

Replicate Object  edit tool.

When a **Roof Truss**  is moved, it snaps to two things:

- If drawn along an exterior wall, it snaps so that its outer surface is flush with the outer surface of the wall’s Main Layer.
- The center line can snap to the edge or corner of a nearby roof plane.

To prevent this, special snapping, check **No Special Snapping** in the **Roof Truss Specification** dialog. See “General Tab” on page 480.

In addition, when a **Roof Truss**  is moved, its shape updates to conform to the structural conditions defined by the roof and ceiling in its new location. As a result, a Roof Truss's label could change when the truss is moved to a new location. To prevent this from occurring, check **Lock Truss Envelope** in the **Roof Truss Specification** dialog before moving the truss. See “Roof Truss Specification Dialog” on page 479.

This is not the case with **Floor/Ceiling Trusses** : when moved to a location with a different platform structure, a Floor/Ceiling Truss will not update to conform to its new surroundings. It is important to draw, position, and copy them within the same floor or ceiling platform structure. If a different Floor/Ceiling Truss depth is needed, a new truss should be drawn.

Editing Truss Envelopes

When a truss is viewed at a 90° angle in a 3D view, its envelope, or shape, can be edited. Click on the truss to select it and edit handles display on a surrounding polyline. Change the shape of this polyline and the truss regenerates inside it. Use this function to change overhang or truss end details rather than the overall truss shape.

The **Lock truss and webbing** attribute is set after editing so that the truss does not reshape itself back between the roof and ceiling planes the next time it is edited or otherwise changed. See “Roof Truss Specification Dialog” on page 479.

Truss Labels

Labels for roof trusses display in floor plan view when the “Framing, Roof Truss Labels” layer is turned on in the **Layer Display Options** dialog. Similarly, floor and ceiling trusses display in the floor plan view when the “Framing, Floor/Ceiling Truss Labels” is turned on. Truss labels use the Text Style associated with their layer. See “Layer Display Options Dialog” on page 104.

Note: Truss labels only display when the trusses they identify are also displaying. See “Displaying Trusses” on page 472.

Truss labels are also used in the Materials List, where they are listed under the Size column. See “Displaying Trusses” on page 472.

By default, truss labels are centered on the truss that they identify. If the truss is moved or deleted, the label is moved or deleted as well. Truss labels have their own Move edit handle which displays when their truss is selected. See “Editing Trusses” on page 473.

Truss labels obey the **Minimum Display Size** for labels set in the **Preferences** dialog. See “Appearance Panel” on page 61.

Truss Label Format

Roof truss labels use the format TR-X, where X is a number indicating the order in which each distinct truss configuration was created. For example, the first truss type created in a plan is labeled TR-1; the second, TR-2; and so on.

Floor and ceiling trusses are labeled FTR-X and use the same numbering convention.

If two or more trusses share the same configuration with identical chords and webbing, they will also share the same truss label.

Mixing Trusses with Stick Framing

After the trusses for your roof are in place, the **Build Framing** dialog can be used to create roof framing in areas not framed by the trusses. See “Mixing Rafters and Trusses” on page 439.

The framing produced is extended or truncated where it encounters a truss. The

exception to this truncation is that hip ridges and common rafters at the end of a hip roof can pass over a drop hip truss.

Lookouts at a gable end are modeled to pass over a truss at the gable and end at the next truss in. Both standard and hip ridges are chopped into blocking between the trusses.

Hip Trusses



A variety of different hip truss configurations can be created, including:

- Step Down Hip trusses
- Drop Hip or California Hip trusses
- Subgirder Hip trusses





Step Down Hip

Step Down hip roofs are the quickest style of hip truss framing to produce.

To create a step down hip truss system

1. First, draw a **Roof Truss**  at the apex of the triangular hip roof plane. When **Object Snaps**  are enabled, it will

snap into position. See “Object Snaps” on page 110.

2. Select the truss; click the **Transform/Replicate Object**  edit button; and create enough copies of the truss in the direction of the hip to reach a reasonable minimum height. See “Transform/Replicate Object Dialog” on page 166.
3. Using the **Roof Truss**  tool, draw hip jacks along the hip ridge from the last truss out into the overhang.
4. Using the **Roof Truss**  tool, draw a jack truss from the intersection of the last hip truss and the hip jack to the eave.
5. Select the jack truss; click the **Transform/Replicate Object**  edit

button; and lay out jack trusses up to the other hip jack.

Drop Hip or California Hip

A Drop Hip, or California Hip, system uses trusses with lowered top chords to support stick frame hip ridges and common rafters.

To create a drop hip truss system

1. Start a drop hip truss system as you would a step down hip system.
2. When the hip trusses are drawn, group select them, open the **Truss Specification** dialog, and select the **Drop Hip Truss** check box. See “General Tab” on page 480.
3. Use the **Build Framing** dialog to produce the common rafters, and the short joists at the hip end. See “Build Framing Dialog” on page 443.



The amount that the top chord is lowered is derived from the rafter **Depth** on the Roof tab of the **Framing Defaults** dialog. Because both common rafters and hip ridges must

pass over this truss, the ridge depth should be set equal to that of the rafter depth.

Subgirder Hip

Subgirders are the partial trusses that butt into the doubled truss at the end of the main run.

To create a subgirder truss system

1. Draw a **Roof Truss**  where the hip apex meets the ridge.
2. Double it by drawing a second truss on the far side from the hip section.
3. Using the **Roof Truss**  tool, draw the first subgirder from the hip apex out to the eaves.
4. Select it and use the **Transform/Replicate Object**  edit button to make copies in both directions. Stop when the height of the subgirders reach a reasonable minimum.
5. Finish off with hip jacks and jack trusses as in a step down hip system.

Special Roof Trusses

A number of special purpose roof trusses can be created in Home Designer Pro.

Energy Heels

To provide more space for ceiling insulation at the exterior walls, roofs are sometimes

raised off of the top plate with an energy heel. To create a truss with an energy heel, a vertical member is added over the supporting wall and the bottom chord stops there rather than extending into the overhang.

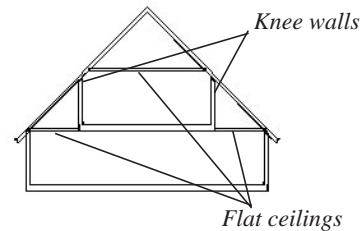
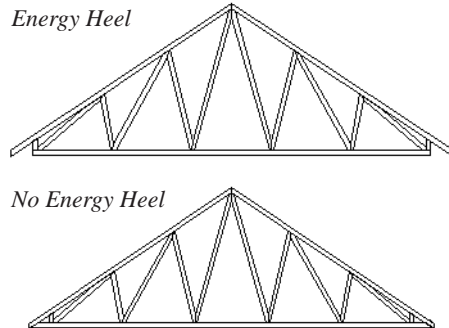

To create an energy heel

1. In the **Build Roof** dialog:
 - Check **Trusses (no Birdsmouth)**;
 - Uncheck **Automatic Birdsmouth Cut**;
 - Specify the desired energy heel height as a positive **Raise Off Plate** value.
2. Automatically generate or manually draw the roof planes.
3. Draw and position the first truss. See “To draw and replicate trusses” on page 471.
4. Open this truss’s specification dialog and check **Energy Heel** and **Force Truss Rebuild**, then click **OK**. See “Roof Truss Specification Dialog” on page 479.
5. Use the Transform/Replicate Object  edit tool to replicate the truss as needed.

Attic Trusses

Attic trusses, a variation of roof trusses, can be drawn if a plan contains an Attic area on both sides and above an upstairs room, such as in a Cape Cod style home. The following is a typical cross section view of a building with attic trusses:

Certain conditions must be met before an attic truss can be built:

- The structure should be sufficiently wide to allow for a loft and attic spaces.
- The loft area must be on a living floor. It cannot be on the Attic floor. See “The Attic Floor” on page 327.
- The loft area must have Attic rooms on both sides. See “Room Types” on page 234.
- The loft area must be separated from the Attic rooms on both sides by Knee Walls. See “Knee Walls” on page 206.
- A flat ceiling in the loft area and a floor below must be present.
- The roof pitch must be steep enough to provide appropriate ceiling height for the loft area. Typical pitches for such a condition are 8 in 12 or greater.
- The roof should bear on the walls of the floor below the loft area and form continuous planes from ridge to baselines.

Once these conditions are met, a roof truss is ready to be designated as an attic truss.

1. Select the roof truss in floor plan view and click the **Open Object**  edit button to display the General tab of the **Roof Truss Specification** dialog.

2. Select the **Attic Truss** check box and click OK. See “Roof Truss Specification Dialog” on page 479.

Ceiling Steps

If a roof truss is drawn across areas with different ceiling heights on the top floor of a plan, the bottom chord will automatically step to accommodate those ceiling heights.

In addition, a roof truss can be made to recognize ceiling heights on two different floors: one on the top floor of the structure and one on the floor below.

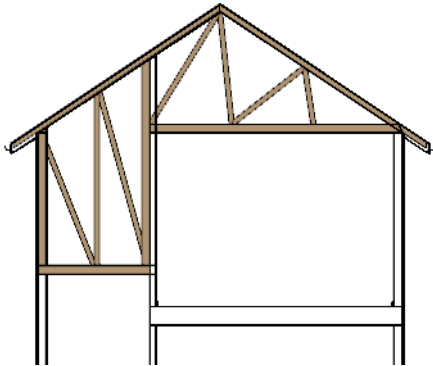

To create a ceiling step

1. The area in which the step is to be produced must be a separate room specified as an “Attic”. See “Room Types” on page 234.
2. Select the roof truss in floor plan view and click the **Open Object**  edit button to display the General tab of the **Roof Truss Specification** dialog.
3. In the **Ceiling Step** field, specify the distance that the bottom chord must step down to locate the ceiling platform of the room beneath the Attic.

- If the Ceiling Step value will place the bottom of the stepped bottom chord within the ceiling platform, a step will be created to the bottom of the ceiling platform.
- Check **Force Truss Rebuild**, then click **OK** to regenerate the truss.

4. Use the Transform/Replicate Object  edit tool to replicate the truss within the area of the roof plan requiring a step.

For best results, you may want to make sure that the Bottom Chord is the same depth as the ceiling platform framing. See “Structure Tab” on page 245.

Scissors Trusses

Trusses drawn between roof planes and sloping ceiling planes of a different pitch than the roof are called Scissor trusses. See “Ceiling Planes” on page 379.

The following is an example of a scissors truss drawn beneath a 8 in 12 pitch gable roof and above 4 in 12 pitch ceiling planes.

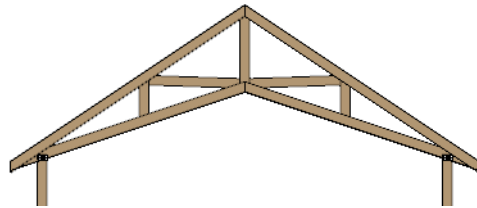

Girder Trusses

Girder trusses provide support for trusses that are cut short, for example, by a reverse gable or a skylight. They are often doubled- or tripled-up for strength.

Draw a new truss from an existing truss to the roof edge, as you would to draw a hip or

end jack truss; or draw a truss between two trusses, forming a girder. This may be necessary for a large opening, such as a skylight.

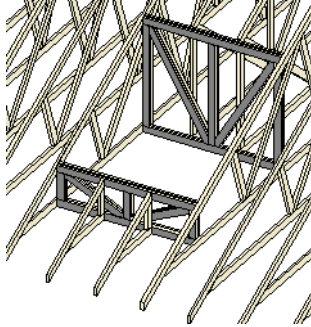

Trusses cannot be drawn through each other. If a truss is drawn through an existing truss, the program automatically shortens it so that it butts into the existing truss.

Roof Truss Specification Dialog



Select a roof truss or group of roof trusses and click the **Open Object** edit button to open the **Roof Truss Specification** dialog.

The **Roof Truss Specification** dialog allows you to redefine parts of an existing truss or group of trusses. Some settings affect only individual trusses, such as gable trusses, while others affect the whole group.

The shape or volume of a roof truss is controlled by the roof planes above it and the ceiling planes below it. It cannot be changed from this dialog.

General Tab

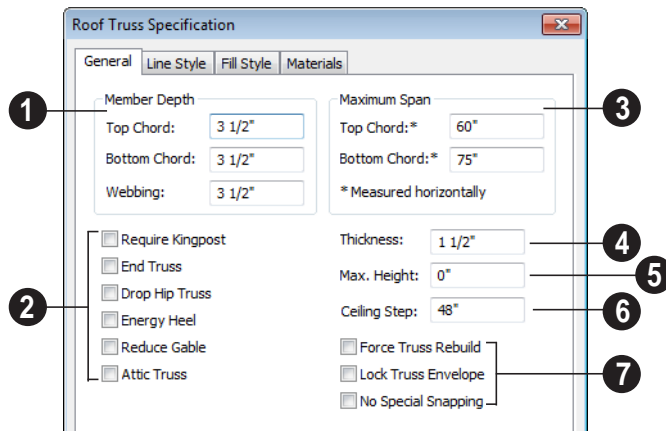

1 Specify the **Depth** of the different members that form the selected truss.

- Specify the depth of the **Top Chord**.
- Specify the depth of the **Bottom Chord**.
- Specify the depth of the **Webbing**.

2 Specify the structure of the selected truss.

- Check **Require Kingpost** to require a vertical webbing member from the roof peak to the bottom chord.

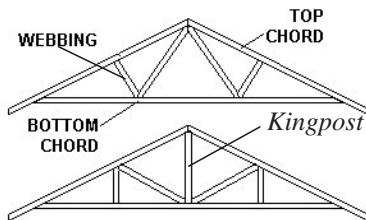

If Require Kingpost is unchecked, a kingpost may still be supplied, depending on the truss length and the specified maximum spans.

- Check **End Truss** to replace the webbing with vertical members positioned and spaced the same as the wall studs below.

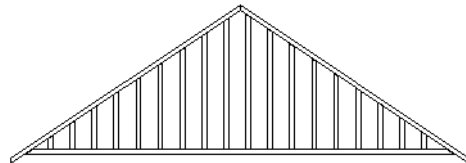

End Truss with vertical supports

If an End Truss is in the same position as a gable attic wall, it replaces the framing that would otherwise be produced for that wall.

- Check **Drop Hip Truss** to lower the flat top of a truss in the hip area of a roof so that common rafters and hip ridges can pass over and be supported by it. See “Drop Hip or California Hip” on page 476.

- Check **Energy Heel** to model remove the bottom chord from the overhang area. For an energy heel to be modeled, the roof should also be raised off the top plates by

at least 7", depending on the roof pitch. See "Energy Heels" on page 476.

Energy Heel

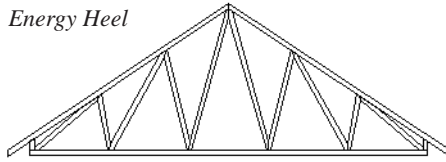

No Energy Heel

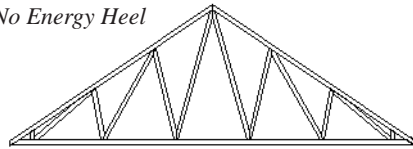

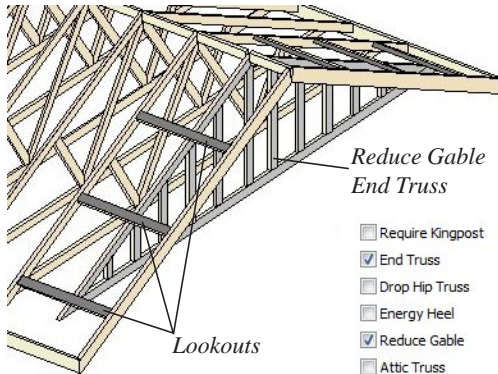

- Check **Reduce Gable** to lower the top chord of an End Truss so that lookouts can pass over the truss. Reduced trusses do not have overhangs, but you can draw short rafters drawn at the ends of the truss.



- Check **Attic Truss** to specify an attic truss. See "Attic Trusses" on page 477.
- 3** Specify the **Maximum Span**, which is the maximum horizontal distance between supports along the **Top Chord** and the **Bottom Chord**. When these values are equal, the truss webbing often appears more regular.

The default Maximum Span settings are set in the **Build Framing** dialog. See "Trusses Tab" on page 453.

 Truss webbing is drawn for representational purposes only and as with trusses in Home Designer Pro in general, is not engineered.

- 4** Specify the **Thickness**, or truss width in floor plan view. This setting overrides default settings.
 - 5** Specify the **Maximum Height** of the selected truss.
 - 6** Specify the **Ceiling Step** of the selected truss, which is the maximum distance its bottom chord can step down to locate a ceiling on the floor below the top floor. See "Ceiling Steps" on page 478.
 - 7** Specify special truss behaviors.
- Check **Force Truss Rebuild** to rebuild the truss envelope based on the current state of the ceiling and roof when you click **OK**. Not available if Lock Truss Envelope is checked.
 - Check **Lock Truss Envelope** to lock the size and configuration of the selected truss. If a locked truss is moved, it will maintain its original settings and will not fit properly if the new roof and ceiling conditions are different from the original.
 - Check **No Special Snapping** to prevent the selected truss from snapping along its long edge to a wall's Main Layer or to the corner of a roof plane. If enabled, **Object Snaps**  may still occur. See "Object Snaps" on page 110.

Line Style Tab

The settings on this tab affect the appearance of the selected truss in floor plan view only. See “Line Style Tab” on page 781.

Materials Tab

The settings on the Materials tab affect the appearance of the selected truss in 3D views. See “Materials Tab” on page 635.

Fill Style Tab

The settings on this tab affect the appearance of the selected truss in floor plan view. See “Fill Style Tab” on page 792.

Floor/Ceiling Truss Specification Dialog



To open the **Floor** or **Ceiling Truss Specification** dialog, select a floor truss in floor plan view and click the **Open Object** edit button. See “Floor and Ceiling Trusses” on page 470.

Default values for trusses are set in the **Build Framing** dialog. See “Trusses Tab” on page 453.

General Tab

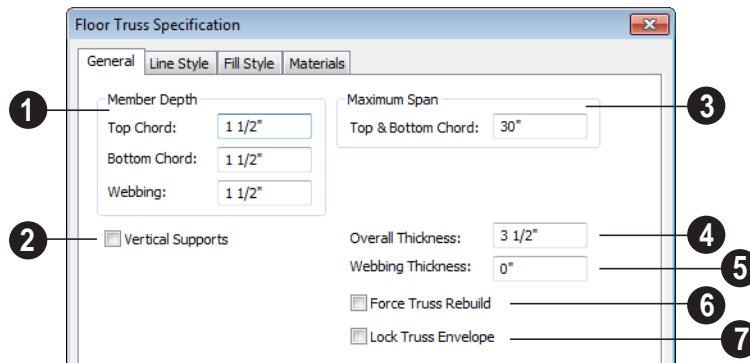

- 1 Specify the **Depth** of the different members that form the selected truss.
 - Specify the depth of the **Top Chord**.
 - Specify the depth of the **Bottom Chord**.
 - Specify the depth of the **Webbing**.

- 2 Check **Vertical Supports** to use vertical supports in the selected truss.
- 3 Specify the **Maximum Span**, which is the maximum horizontal distance between supports along the **Top & Bottom Chord**.

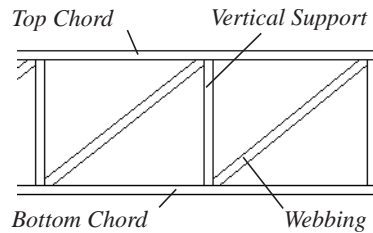

- 4 Specify the **Overall Thickness** of the selected truss.
- 5 Specify the **Webbing Thickness** thickness of the webbing.
- 6 Check **Force Truss Rebuild** to rebuild the truss envelope based on the existing floor or ceiling platform when you click OK. Not available if Lock truss envelope is checked, below.

- 7 Check **Lock Truss Envelope** to lock the size and configuration of the truss. A locked truss which has been relocated will maintain its original settings.

Line Style Tab

The settings on this tab affect the appearance of the selected truss in floor plan view only. See “Line Style Tab” on page 781.

Fill Style Tab

The settings on this tab affect the appearance of the selected truss in floor plan view. See “Fill Style Tab” on page 792.

Materials Tab

The settings on the Materials tab affect the appearance of the selected truss in 3D views. See “Materials Tab” on page 635.

Electrical

The electrical plan shows the location of all electrical objects such as lights, switches, outlets, smoke detectors and vent fans. Basic wiring diagrams show which objects share circuits and the locations of the controlling switches.

Electrical objects can be displayed in 2D and 3D views. Some electrical light fixtures also add light sources to 3D views. See “Lighting” on page 699.

Usually, the electrical plan is one of the last additions to a plan since the position of most electrical objects is determined by the location of walls, cabinets and other objects.



Building requirements vary throughout the country and around the world. It is your responsibility to comply with local codes.

Chapter Contents

- Electrical Defaults
- The Electrical Tools
- Creating Wiring Schematics
- Auto Place Outlets
- Electrical Library
- Displaying Electrical Objects
- Editing Electrical Objects
- Electrical Service Specification Dialog

Electrical Defaults



Default Settings for electrical objects control which symbols are placed in the current plan when the Electrical Tools are used and can be accessed by selecting **Edit> Default Settings** from the menu or by

double-clicking the **Electrical Tools**  button. See “Default Settings” on page 56.

Default heights of individual objects can be overridden in the **Electrical Service Specification** dialog. See “Electrical Service Specification Dialog” on page 492.

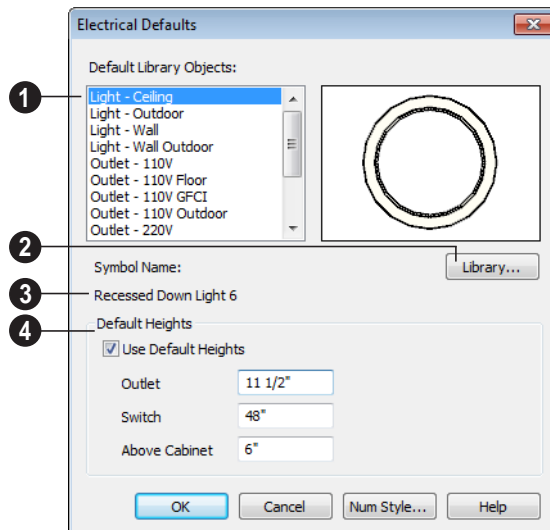

1 Default Library Objects - These are the items used when electrical objects are created or automatically generated using the Electrical Tools. Select an item in the scrollable list to see a preview image to the right and the symbol’s name below.

2 Select an item in the Default Library Objects list and click the **Library** button to select a new default object from the library. See “Select Library Object Dialog” on page 622.

3 Symbol Name - The name of the object shown in the preview image displays here.

4 Default Heights - Specify the heights at which electrical outlets and switches are initially placed.

- Check **Use Default Heights** to apply the default heights specified here to electrical objects placed directly from the library in floor plan view. See “Placing Library Objects” on page 620.
- **Outlet** - Specify the default height for outlets, and phone, cable and tv jacks.

- **Switch** - Specify the default height for switches, doorbells and thermostats.
- **Above Cabinet** - Specify the default height for switches and outlets placed

above most cabinets in floor plan view, as measured from the countertop. See “Adjusting the Height of Electrical Objects” on page 491.

The Electrical Tools



Select **Build> Electrical** to access the Electrical Tools.

Click in floor plan view to place an electrical object. Some can only be placed against walls, some only on the ceiling or floor, and some automatically change as needed. If you click within 12" of the wall, the selected object is placed on the wall.

Electrical objects are placed according to the settings in the **Electrical Defaults** dialog.

Once an electrical object has been placed, it can be edited in the **Electrical Service Specification** dialog. See “Electrical Service Specification Dialog” on page 492.

Outlets



Select **Build> Electrical> 110V Outlet** to place 110 volt duplex outlets in walls or on the floor. Select **Build> Electrical> 220V Outlet** to place 220 volt outlets.

Certain room types and situations cause various types of outlets to be placed. For example:

- In rooms defined as Kitchen, Bath or Master Bath, Ground Fault Circuit Interrupt (GFCI) outlets are placed.



If standard outlets are placed in a room prior to defining it as a Kitchen or Bath, you should replace them with GFCI outlets.

- Outlets placed on the wall behind a base cabinet containing a dishwasher or sink are placed at the normal 12" (300 mm) above the floor. If an outlet is placed above a cabinet, the default Above Cabinet Default Height is used instead.
- Outlets placed outside the building or in an exterior area such as a deck or porch are labeled WP, or Water Proof.

To take advantage of the program’s capabilities, define room types properly before placing electrical objects. See “Room Types” on page 234.

Light Fixtures



Select **Build> Electrical> Light** to place light fixtures as specified in the **Electrical Defaults** dialog. All light fixtures placed in a plan can also serve as light sources in most 3D views. To place a light fixture using the Light tool

- Click near a wall to place a wall-mounted fixture at that location.
- Click away from a wall to place a ceiling mounted light.

- Some light symbols from the library can be mounted under wall cabinets, as well.

The rendering characteristics of individual lights that control how they appear in Render views can be specified on the Light Data tab of the **Electrical Service Specification** dialog. See “Light Data Tab” on page 493.

Switches



Select **Build> Electrical> Switch** to place electrical switches as specified in the **Electrical Defaults** dialog. Like outlets, the height of switches is measured from the floor to the center of the object.

An electrical switch can be placed on either a wall or a cabinet, depending on the type of switch. A selection of each type is available in the Library Browser. See “Placing Library Objects” on page 620.



If you connect two or more switches in a circuit, they update to 3-way or 4-way switches automatically.

Switches placed from the Electrical Library do not automatically update by default, but can be specified to do so. See “Electrical Service Specification Dialog” on page 492.

Lighting and Electrical Libraries



A selection of free-standing and ceiling-, wall- and cabinet-mounted light fixtures is available in the Library Browser at Home Designer Core Catalogs> Architectural> Lighting.

Special use outlets, switches, jacks and numerous other electrical items can be found at Home Designer Core Catalogs> Mechanical, Electrical, Plumbing> Electrical. See “The Library” on page 603.

Creating Wiring Schematics

Electrical schematics can be created in two ways. Using the **Connect Electrical**  tool is quick and easy, but if you need detailed schematics, you can create your own wiring diagrams using the CAD tools.

Connect Electrical



Select **Build> Electrical> Connect Electrical** to illustrate circuits. Using this tool, you can show which lights and outlets are attached to any given switch.

To create a new circuit or to add to an existing circuit, click one electrical object

while using **Connect Electrical**  tool, drag to the next object and release. You can also draw electrical circuits using the

Alternate  continuous drawing mode. See “Alternate” on page 121.

Remove an electrical object from a circuit by selecting it and clicking the **Delete**  edit button. See “Deleting Objects” on page 171.

More than one switch can control an object or group of objects. Two switches controlling the same objects are referred to as three-way switches. Three switches controlling the same objects are called four-way switches.

The number of “ways” is one more than the number of switches in the same circuit. This

number displays with the switch symbol in floor plan view.

Auto Place Outlets



Select **Build> Electrical> Auto Place Outlets** and click in a room tool to place outlets, usually 110 volt, around the entire room at intervals not greater than twelve feet so that no wall position is farther than six feet (1800mm) from the nearest outlet.

Outlets are placed based on settings in the **Electrical Defaults** dialog. See “Electrical Defaults” on page 486. It is important that the room type be defined before using **Auto**

Place Outlets so that outlets are placed appropriately in each room type. For example, GFCI (Ground Fault Circuit Interrupter) outlets are placed over cabinets in Kitchen, Bath and Master Bath rooms

Stand-alone or built-in appliances such as ranges, washers, and dryers each have their required 110 volt or 220 volt outlets placed

automatically. Lights are always placed above sinks.

Auto Place Outlets requires a room to have a door before outlets are automatically placed and does not work in any room defined as an exterior room. Exterior rooms require that the outlets be placed individually using the **110V Outlets** tool or from the Electrical Library. See “Room Types” on page 234.

Railings and invisible walls do not separate rooms for **Auto Place Outlets** : If **Auto Place Outlets** is used in a room defined by railings or invisible walls, outlets are automatically placed in all adjacent rooms that share these wall types with that room.

Any outlet can be moved, deleted, or merged with other outlets or switches. See “Switches” on page 488.

Electrical Library



Select **Library> Library Browser** to access a variety of electrical symbols. See “The Library” on page 603.

Browse for electrical objects such as bath vent fans, an electrical panel, fluorescent lights, chandeliers, a smoke detector, thermostat, and more. Select a symbol, then

click in your plan to place it on a wall, floor, or ceiling.

You can also assign electrical objects from the library to toolbar buttons for easy access and placement to frequently-used library objects. See “Place Library Object Button” on page 623.

Displaying Electrical Objects



The display of electrical objects and connections is controlled in the **Layer Display Options** dialog. See “Displaying Objects” on page 102.

When displayed in 3D views, light fixtures act as sources of light that help illuminate the 3D model. See “Lighting” on page 699.

Electrical Labels

Electrical labels display in floor plan view when the “Electrical, Labels” layer is turned on. Electrical labels use the Text Style assigned to their layer. See “Object Labels” on page 884.

Customized labels using text as well as label position and orientation can be specified in the **Electrical Service Specification** dialog.

Note: Some electrical objects are represented in floor plan view by a symbol that includes text. This text is not part of the object’s label and does not use the Text Style assigned to the “Electrical, Labels” layer.

In the Materials List

Electrical objects, including outlets, switches, lights, and symbols from the library such as jacks and fans, are listed under the Electrical Category in the Materials List. See “Materials Lists” on page 887.

Editing Electrical Objects

Electrical objects can be selected as a group and individually in 2D and 3D and edited using the edit handles, the edit toolbar and their specification dialog. See “Electrical Service Specification Dialog” on page 492.

Light fixtures and Added Lights can be group-selected, but their light data cannot be edited unless they have the same number of light sources associated with each. See “Lighting” on page 699.

Lights can also be edited using the **Adjust Lights** dialog. See “Adjust Lights Dialog” on page 704.

Moving Electrical Objects Using Dimensions

Electrical objects can be moved precisely using manual dimensions. See “Moving Objects Using Dimensions” on page 737. First, dimensions must be checked on the Locate Objects tab of the **Dimension Defaults** dialog. See “Dimension Preferences and Defaults” on page 719.

Using the Edit Handles

The edit handles for electrical objects vary depending on the location of the object. Wall mounted electrical objects cannot be rotated, so only the Move edit handle displays.

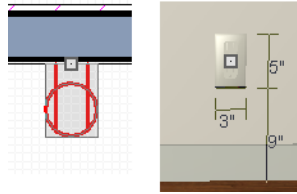

Wall-mounted outlet in 2D and 3D views

Electrical objects placed on floors and ceilings can be rotated.

Electrical connections edit like splines. See “Editing Spline Based Objects” on page 144.

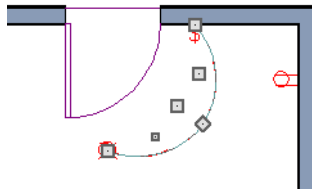

Using the Edit Buttons

A selected electrical symbol can be edited in a variety of ways using the buttons on the edit toolbar. See “The Edit Toolbar” on page 29.

Adjusting the Height of Electrical Objects

The heights where electrical objects display in 3D views are initially based on settings in the **Electrical Defaults** dialog. See “Electrical Defaults” on page 486.

In floor plan view, an outlet placed where a base cabinet meets a wall is placed above the counter unless the cabinet contains a fixture

or appliance other than a bathroom sink. If the fixture requires electricity, the outlet remains behind the cabinet at normal wall height, where it can supply power to the fixture or appliance.

Kitchen sinks are assumed to require electricity since they often contain a garbage disposal. Dishwashers are not considered to require electricity since they are usually plugged in under a nearby sink. If an outlet is needed above a cabinet containing a kitchen sink, place the outlet before adding the sink, or move the outlet up.

To change the height of an electrical object in floor plan view, open the object for specification and type the desired height in the **Electrical Service Specification** dialog. See “Electrical Service Specification Dialog” on page 492.

Electrical objects placed in 3D views are placed wherever you click a wall, regardless of the height. In 3D views, the position of an electrical object can be adjusted using its edit handles.

Deleting Electrical Objects

An electrical object can be deleted by selecting it and clicking the **Delete**  edit button or by pressing the Delete key.

All electrical objects in a room, on a floor, or in the entire plan can be deleted as a group using the **Delete Objects** dialog. See “Deleting Objects” on page 171.

Electrical Service Specification Dialog

 Select one or more electrical objects and click the **Open Object** edit button to open the **Electrical Service Specification** dialog. The settings in this dialog vary, depending on the type of object(s) you select.

The **Electrical Service Specification** dialog consists of four tabs:

- The General Tab specifies the location of the selected electrical object(s).
- The Light Data Tab specifies how lights appear in rendered views. Not available for switches or outlets. See “Lighting” on page 699.
- The Materials Tab allows you to change materials on electrical objects.
- The Label Tab lets you specify the selected object’s label.

General Tab

The items on this tab vary, depending on the type of electrical object selected.

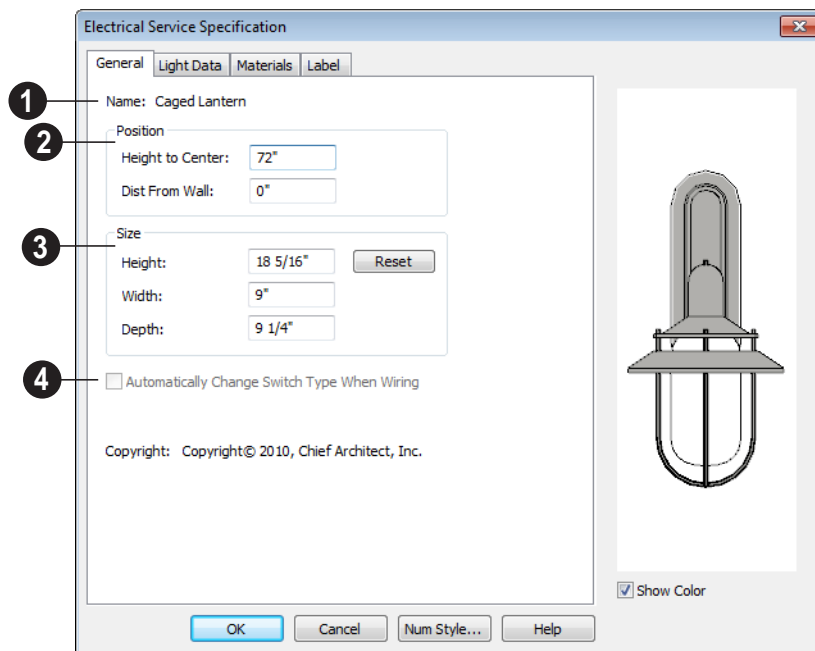

- 1** The **Name** of the selected object as used in the Library Browser and

Materials List displays here.

- 2 Specify the **Position** of the selected electrical symbol. The options available depend on the type of electrical symbol selected.
 - Specify the **Offset From Ceiling** of a ceiling outlet or ceiling mounted light. If the light is mounted to a cabinet, this value is the offset from the cabinet.
 - Specify the **Height to Center** of a switch, wall outlet or wall light.
 - Specify the **Offset From Floor** of a floor outlet or floor lamp.
 - Specify the **Distance From Wall** of a wall mounted symbol. A negative value will recess the symbol into the wall and may prevent it from being seen in 3D.
- 3 Specify the **Size** of the selected electrical symbol.
 - Specify the **Height, Width and Depth** of the selected symbol.
 - Click the **Reset** button to restore the electrical symbol's original size
- 4 Check **Automatically Change Switch Type When Wiring** for a selected switch to become a three- or four-way switch if your wiring plan later uses it as such. See "Connect Electrical" on page 488. Switches placed from the toolbar use this option by default; switches placed from the library do not. Only available for switches.

Light Data Tab

The Light Data tab is available when the selected electrical object is a light fixture. The available options vary depending on the type of light selected.

The settings on this tab are similar to those on the same tab of the **Light Specification** dialog. See "Light Specification Dialog" on page 706.

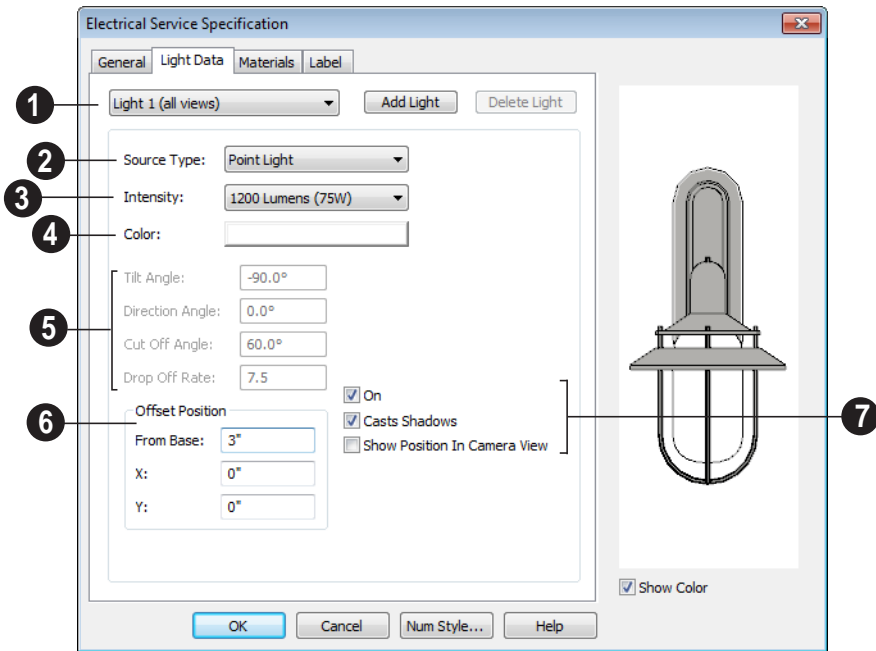

- 1 The currently selected Light Source displays here. Each fixture can have multiple light sources. Not available for Added Lights. See “Lighting” on page 699.
 - Select an existing Light Source associated with the selected light fixture from the drop-down list .
 - Click **Add Light** or **Delete Light** to add or delete light sources from the list. If the selected fixture has only one light source, Delete Light will not be available.
- 2 Select a light **Source Type** from the drop-down list for the currently selected Light Source. The type selected determines what options are enabled on this tab. See “Light Types” on page 705.
- 3 Select an **Intensity** from the drop-down list. The available options are described

using lumens and correspond to commonly used light bulb wattages.

- Select “Custom” from the list to open the **Custom Light Intensity** dialog and create a custom Intensity setting. See “Custom Light Intensity Dialog” on page 495.

- 4 Click the **Color** bar to define the color of the selected light source. Colored lights alter the appearance of textures and can be used to achieve special effects. See “Color Chooser Dialog” on page 651.

The default color of light is pure white, which has the least affect on the appearance of material colors and textures.

- 5 Specify the direction and drop off rate of a Parallel or Spot Light source. Not

available when the selected Source Type is Point Light.

- The **Tilt Angle** controls the angle of the illumination with respect to the horizon. A value of -90° points the light straight down and a value of 90° points it straight up. 0° is parallel to the horizon.
- The **Direction Angle** defines the direction of the illumination relative to the ground. 0° is measured horizontally pointing to the right. Positive values rotate in a counter-clockwise direction from there. Enter a value up to 360° . If you enter a negative value, the program adds 360° to it when you click OK or press the Tab key.
- The **Cut Off Angle** controls the angle of the cone of illumination for Spot Lights only. A cone angle of 180° creates a spot light that shines in a half sphere on one side of the light source. A small cone angle, for example 10° , creates a very narrow cone of light. The cut off angle should always be between 0° and 180° .
- The **Drop Off Rate** affects how fast the intensity of illumination drops off from the center of the cone to the outside edge. This is only available for Spot Lights.

The default drop off value is 7.5, which means the light drops off fairly quickly. Do not set this value too low because there are limitations in the OpenGL lighting model that result in jagged circles of light when they are shining on large flat surfaces. Appearances can be improved by decreasing the Maximum

Triangle Size and increasing the Drop off Rate.

- 6 **Offset Position** gives you control over the location of the light source relative to the fixture.
 - **From Base** controls how far the light source is from the fixture base. The fixture base is determined by the surface that it is attached to (i.e. wall, floor, or ceiling).
 - **Offset in X/Offset in Y** allow you to position the light source relative to the center of the fixture, along the floor/ceiling.
- 7 Additional display options are available here.
 - Check **On** to use the light source is used in camera or ray trace views, or uncheck it if you prefer that the light source not be used. See “Lighting” on page 699.
 - **Casts Shadows** controls whether or not the light source casts shadows in Final Views with Shadows. See “Previews vs Final Views” on page 698.
 - Check **Show Position in Camera View** to indicate the position of a selected Point or Spot Light source in 3D views when it is turned On. This tool can be used to determine if your light source is positioned correctly.

Custom Light Intensity Dialog

Select “Custom” from the **Intensity** drop-down list on the Light Data tab to open the **Custom Light Intensity** dialog.

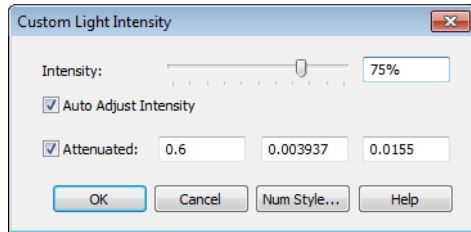

- **Intensity** - Use the slider bar or text field to control how bright the light appears in camera views.
- Check **Auto Adjust Intensity** to have the program to scale the Intensity depending on the number of lights in the room. When unchecked, the Intensity set here is used.
- Check **Attenuated** to control how quickly a light source's intensity drops as its distance from the light source increases. When unchecked, the light does not drop off. Only Spot and Point Lights have attenuation.

The three **Attenuated** values represent the three coefficients (a, b, and c) in the expression $1 / (a + b*d + c*d*d)$, where d is

the distance from the light source. Increasing any of these values results in the light intensity dropping faster (the light does not travel as far). Decreasing any value results in the light intensity dropping slower (the light travels farther). Small changes in these coefficients can have significant impact on lighting effects. You may need to experiment to fully understand how to use them.

Materials Tab

The Materials tab is found in the specification dialogs for a variety of objects. For more information, see “Materials Tab” on page 635.

Label Tab

Labels for electrical fixtures display when the “Electrical, Labels” layer is turned on and use the Text Style assigned to that layer. See “Electrical Labels” on page 490.

For information about the settings on this tab, see “Label Tab” on page 885.

Trim & Molding

The Trim Tools allow you to place corner boards and quoins at wall intersections that form corners.

You can also assign moldings to a variety of objects, such as rooms and cabinets, in those objects' specification dialogs. See "Specification Dialogs" on page 31.

Chapter Contents

- Trim and Molding Defaults
- Corner Boards
- Corner Board Specification Dialog
- Quoins
- Quoin Specification Dialog
- Editing Corner Boards and Quoins
- Millwork
- Moldings Tab

Trim and Molding Defaults



Select **Edit> Default Settings** to open the **Default Settings** dialog where you can access the defaults for a variety of drawing tools, including a number that affect trim and moldings.

- Click the + beside “Corner Trim” to access the defaults for Corner Boards and Quoins. See “Corner Boards” on page 498 and “Quoins” on page 500.
- Select “Floor” and click the **Edit** button to specify the default moldings for rooms on the current floor. See “Floor Defaults” on page 230.
- Click the + beside “Door” to access the defaults for Interior and Exterior Doors. See “Door Defaults” on page 253.
- Select “Window” and click the **Edit** button to specify the default casing for windows. See “Window Defaults” on page 280.
- Click the + beside “Cabinet” to access the defaults for the Cabinet Tools, where you can specify default crown and other moldings. See “Cabinet Defaults” on page 507.

Corner Boards



Corner boards are added to a building exterior in any view by selecting **Build> Trim> Corner Boards**.



Click at a wall corner where you want to add trim. Be sure to click where the outside wall surfaces meet. If you click where the inside surfaces meet, corner trim will be created inside the room.

You can also add Corner Boards to all exterior corners at once by selecting **Build> Trim> Auto Place Corner Boards** .

By default, **Auto Place Corner Boards**  adds Corner Boards to outside corners only. If you prefer, you can specify that inside corners receive corner boards in the **Corner Board Defaults** dialog. See “General Tab” on page 499.

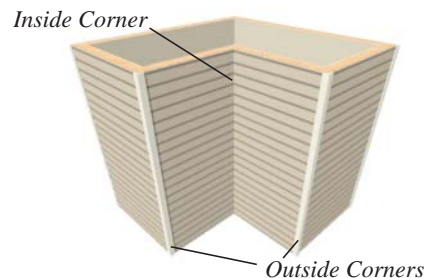

Note: The Auto Place Corner Boards tool does not place corner boards on manually drawn dormers or at intersections with Attic Walls. See “Attic Walls” on page 206.

Corner boards extend from the top plate down to the bottom of the floor platform of the floor on which it is placed, but do not extend to other floors. You must add corner boards to all floors of the building that you want to have corner boards.

A selected corner board or boards can be moved, but only to another wall corner or corners. In 3D views, corner boards can be

lengthened or shortened using the edit handles. Corner boards can be copied, deleted and resized similar to other objects using the edit toolbar or the **Corner Board Specification** dialog.

The default material for corner boards is defined by the **Exterior Trim** entry in the **Material Defaults** dialog. See “Material Defaults” on page 650.

Corner Board Specification Dialog



Select one or more corner boards and click the **Open Object** edit button to open the **Corner Board Specification** dialog.

The settings in this dialog are similar to those in the **Corner Board Defaults** dialog, but affect the selected corner boards rather than all subsequently created corner boards.

General Tab

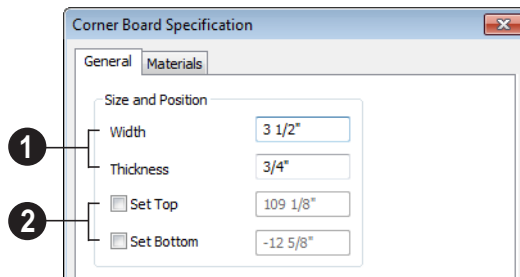

- 1 Specify the **Width** and **Thickness** of the selected corner board(s).
- 2 Check **Set Top/Set Bottom** to specify the top and bottom heights of the corner board(s).
 - If **Set Top** is unchecked, the top of the corner board automatically extends to the top plate.
 - If **Set Bottom** is unchecked, the bottom of the corner board automatically extends to the bottom of the floor platform.

In the **Corner Board Defaults** dialog, an additional **Auto Place Option** is available.

- Check **Include Inside Corners** to place Corner Boards on inside corners when the **Auto Place Corner Boards**  tool is used. When unchecked, only outside corners receive corner boards.

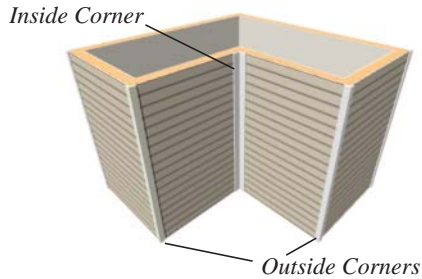

Materials Tab

The settings on the Materials tab are available for a wide variety of objects in the program. For information about these settings, see “Materials Tab” on page 635.

Quoins



Select **Build > Trim > Quoins** in any view and click at a wall corner where you want to place quoins.



You can also add Quoins to all exterior corners at once by selecting **Build > Trim >**

Auto Place Quoins .

By default, **Auto Place Quoins**  adds Quoins to outside corners only. If you prefer, you can specify that inside corners receive quoins in the **Quoin Defaults** dialog. See “General Tab” on page 499.

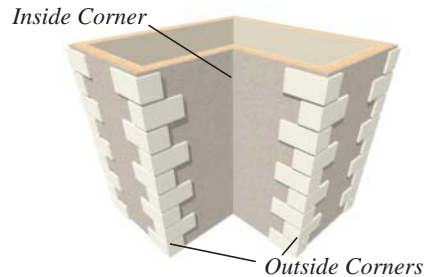

Note: The Auto Place Quoins tool does not place quoins on manually drawn dormers or at intersections with Attic Walls. See “Attic Walls” on page 206.

A selected quoin or quoins can be moved, but only to another wall corner or corners. In 3D views, quoins can be lengthened or shortened using the edit handles. Quoins can be copied, deleted and resized similar to other objects using the edit toolbar or the **Quoin Specification** dialog.

The size of quoins in floor plan view is relative on their size in 3D.

Initially, quoins use the same material as the default material of the wall surface they are placed against. This material is specified in

the **Wall Type Definitions** dialog. See “Wall Specification Dialog” on page 214.

Quoin Specification Dialog



Select one or more quoins and click the **Open Object** edit button to open the **Quoin Specification** dialog.

The settings in this dialog are the same as those in the **Quoin Defaults** dialog, but affect the selected quoins rather than all subsequently created quoins.

General Tab

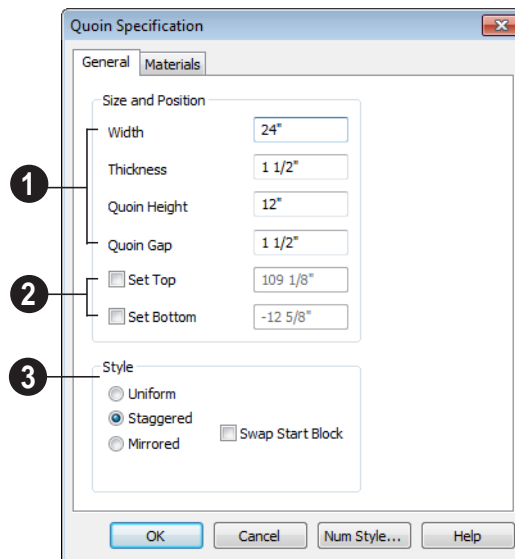

- 1 Specify the dimensions of the quoins in the selected Quoin object.
 - Specify the **Width**, which is the long dimension of each quoin in the selected Quoin object. The dimension along the other wall is half this value when they are staggered or mirrored.
 - Specify the **Thickness**, which is the amount that the quoin protrudes from the exterior surface of the wall.
 - Specify the **Quoin Height** for individual quoins in the selected Quoin object.
 - Specify the **Quoin Gap**, which is the distance between successive quoins.
- 2 Check **Set Top/Set Bottom** to specify the top and bottom heights of the quoin(s) in the text fields.
 - Specify the **Quoin Height** for individual quoins in the selected Quoin object.
 - Specify the **Quoin Gap**, which is the distance between successive quoins.
- 3 Specify the **Style** of the quoin.
 - Select **Uniform**, **Staggered**, or **Mirrored**.
 - Check **Swap Start Block** to swap the start and end blocks.

- If **Set Top** is unchecked, the top of the corner board automatically extends to the top plate.
- If **Set Bottom** is unchecked, the bottom of the quoin automatically extends to the bottom of the floor platform.
- 3 Specify the arrangement of quoins used by the selected Quoin object(s).
- **Uniform** - Produce quoins that are of equal length on both sides of the corner.
- **Staggered** - Produce quoins that have one long side and one short side staggered on opposite sides of the corner.
- **Mirrored** - Produce quoins that alternate having either two long sides or two short sides.
- When Staggered or Mirrored is selected, check **Swap Start Block** to switch the starting order for the quoins.



In the **Quoin Defaults** dialog, an additional **Auto Place Option** is available.

- Check **Include Inside Corners** to place Quoins on inside corners when the **Auto Place Quoins**  tool is used. When unchecked, only outside corners receive quoins.

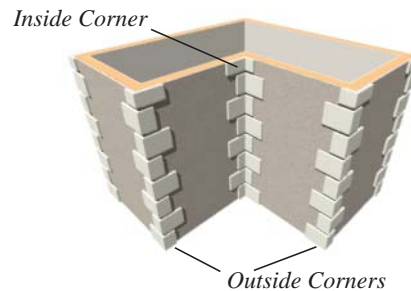

Materials Tab

The settings on the Materials tab are available for a wide variety of objects in the program. For information about these settings, see “Materials Tab” on page 635.

Editing Corner Boards and Quoins

Before a corner board or quoin can be edited, it must be selected. Click on a trim object when the **Select Objects**  tool is active. Corner boards and quoins can also be group selected and edited. See “Selecting Objects” on page 124

Corner boards and quoins can be edited using their edit handles, the edit toolbar buttons, and their specification dialogs.

Using the Mouse

Depending on the type of view, a corner board or quoin displays a different set of edit handles when selected.

- In floor plan view, corner boards and quoins display one edit handle and can be moved from one eligible location at a wall corner to another.

- In 3D views, corner boards and quoins can be moved, lengthened, and shorted much the other line-based objects are. See “Editing Line Based Objects” on page 127.

Using the Edit Buttons

A selected corner board or quoin can be edited in a variety of ways using the buttons on the edit toolbar. See “The Edit Toolbar” on page 29.

Deleting Corner Trim

Corner boards and quoins can be selected individually or in groups and deleted using the **Delete**  edit button or the Delete key on the keyboard. They can also be removed using the **Delete Objects** dialog. See “Deleting Objects” on page 171.

Millwork

A selection of various types of millwork including columns, corbels and finials is available in the Library Browser. See “The Library Browser” on page 604.

Most millwork items can be placed in a plan as free-standing objects. Some items - notably, newels and balusters - can be assigned to objects such as railings, stairs and ramps. See “Placing Library Objects” on page 620.

Moldings Tab

The specification dialogs for a variety of objects in the program include a Moldings tab. Objects that can have moldings assigned to them include rooms, cabinets, and custom countertops.

Select an object or group of similar objects and click the **Open Object**  edit button to open the specification dialog for that selection.

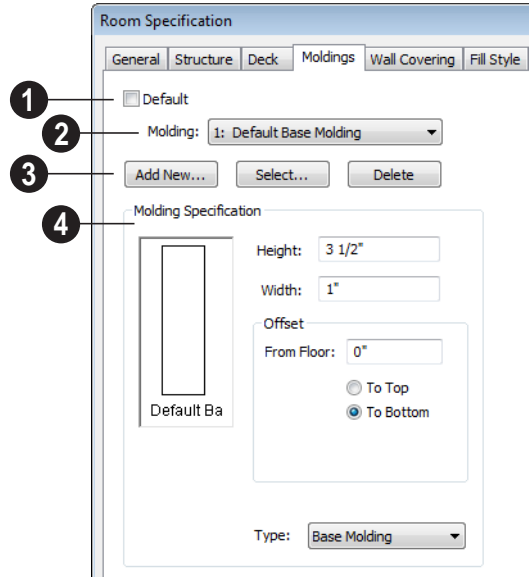

1 Only available for rooms, uncheck **Default** to make the settings that follow active. Check this box to use the defaults set in the **Floor Defaults** dialog for the current floor. See “Floor Defaults” on page 230.

2 A drop-down list of the **Molding** profile(s) assigned to the selected object displays here. Select the name of a molding to edit it or remove it from the list.

- If multiple objects with different moldings assigned to them are selected, a **No Change** checkbox will be available just above the **Molding** drop-down list.

Uncheck this box to make the settings that follow active but note that only moldings that all selected objects have in common will be retained.

3 Add or remove molding profiles and/or symbols from the selected object.

- Click the **Add New** button to open the **Select Library Object** dialog and add a new molding profile or symbol to the list. See “Select Library Object Dialog” on page 622.

- Click the **Select** button to remove the selected profile or symbol and replace it with a new one from the **Select Library Object** dialog. Only available when a profile is already selected.

- Click the **Delete** button to remove the currently selected profile or symbol from the list.

4 **Molding Specification** - Specify the size and position of the currently selected molding.

- Specify the **Height** of the molding profile.
- Specify the profile’s **Width**.

Define the **Offset** of the molding relative to the object it is assigned to.

- Specify the offset **From Floor** of the selected molding profile; for objects other than rooms, specify the **Vertical** offset. A positive offset moves the molding upward and a negative offset moves the molding downward.
- Select **To Top** to specify that the top of the molding is offset vertically from the top of the object it is applied to.
- Select **To Bottom** to specify that the bottom of the molding is offset vertically from the bottom of the object it is applied to.
- Choose the currently selected molding's **Type** from the drop-down list: Base Molding, Chair Rail, or Crown Molding. Only available for rooms.

Cabinets

With Home Designer Pro's cabinet tools you can create base, wall, and full height cabinets as well as soffits, shelves, partitions, and custom countertops. These objects are very versatile, allowing for a wide range of customization.

A selection of cabinet door and drawer styles are available in the Library Browser.

Home Designer Pro also has many customized cabinet symbols and cabinet groups available in the library.

Chapter Contents

- Cabinet Defaults
- The Cabinet Tools
- Cabinet Fillers
- Placing Cabinets
- Custom Countertops
- Displaying Cabinets
- Cabinet Labels
- Editing Cabinets
- Editing Cabinet Styles
- Editing Custom Countertops
- Special Cabinets
- Cabinet Specification Dialog
- Cabinet Shelf Specification Dialog
- Shelf/Partition Specification Dialog
- Custom Countertop Specification Dialog

Cabinet Defaults



Access default settings for each cabinet tool by selecting **Edit> Default Settings**, then clicking the + beside **Cabinets**. Select a subheading and click the **Edit** button to open the defaults dialog associated with your selection:

The Cabinet Defaults dialogs can also be accessed by double-clicking the **Cabinet**

Tools  parent button.

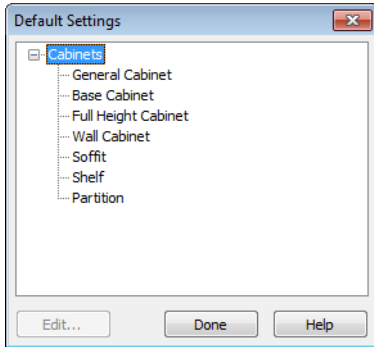

Double-clicking a Cabinet Tools child button also opens its corresponding defaults dialog, if that object has a defaults dialog.

Each type of cabinet object has default definitions for size, style, materials and much more. In fact, the default dialog for each cabinet type is similar to its corresponding specification dialog. For descriptions of these settings, see “Cabinet Specification Dialog” on page 522, “Shelf/Partition Specification Dialog” on page 533 and “Soffit Specification Dialog” on page 592.

Custom Countertops do not have defaults dialogs. Instead, their initial settings are based on the those of other objects.

General Cabinet Defaults

The **General Cabinet Defaults** dialog can be accessed only from the **Default Settings** dialog.

- Custom Countertops’ initial settings are based on Base Cabinet Default settings but are also influenced by the settings of cabinets beneath them. See “Custom Countertops” on page 510.

Dynamic Cabinet Defaults

The following cabinet default values are dynamic: **Separation, Backsplash Height and Thickness, Countertop Overhang and Thickness, Toe Kick Height and Depth, Side and Vertical Overlap, Stiles, and Hardware** spacing. See “Dynamic Defaults” on page 57.

All **Materials** are also dynamic, with one exception: materials assigned to doors and drawers when the default door/drawer is a library symbol. When this is the case, the default door/drawer material is dynamically linked to the “Cabinet Door/Drawer” material set in the **Material Defaults** dialog rather than the **Cabinet Defaults** dialog. See “Material Defaults Dialog” on page 650.

When a dynamic default is changed, existing cabinet objects using the default value are affected.

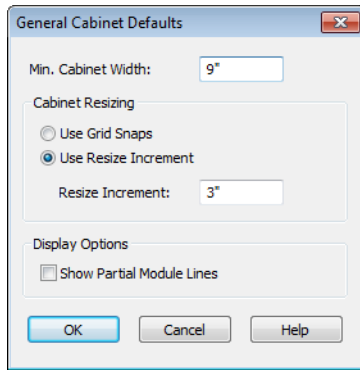

Specify the **Minimum Cabinet Width**. The minimum allowable width is 1/16 of an inch (10 mm).

Specify how **Cabinet Resizing** takes place when the edit handles are used.

- Select **Use Grid Snaps** to resize cabinets using Snap Grid increments. See “Grid Snaps” on page 112.
- Select **Use Resize Increment** to resize cabinets using the increment specified here.
- Set the **Resize Increment** at which cabinets resize. The minimum allowable increment is 1/16 of an inch (10 mm).

Uncheck **Show Partial Module Lines** to display lines between merged cabinet modules as specified by the “Cabinets, Module Lines” layer. Check this box to represent module lines as grey lines that do not extend across the cabinets. See “Displaying Cabinets” on page 514.

The Cabinet Tools



Select **Build> Cabinet** to access the Cabinet Tools.

Cabinets are easily created with a single click in floor plan view or any camera view. See “Click-to-Create” on page 113.

Typically, groups of cabinet objects are positioned closely together and arranged to form work spaces, and there are some special behaviors and techniques to be aware of. See “Placing Cabinets” on page 512.

Once created, cabinets, soffits, shelves, partitions and fillers can be selected and edited much like other box-based objects. See “Editing Cabinets” on page 517.

Base Cabinets



Select **Build> Cabinet> Base Cabinet** and click in any view. Base cabinets can be placed directly under wall cabinets and generate a countertop and toe kick by default.

Wall Cabinets



To place a wall cabinet, select **Build> Cabinet> Wall Cabinet** and click in any view. Wall cabinets can be placed directly over base cabinets.

Full Height Cabinets



To place a full height cabinet, select **Build> Cabinet> Full Height** and click in any view. Full height cabinets

generate a toe kick by default and cannot be placed on top of other cabinets.

Soffits



Soffits typically fill the space between cabinet tops and the ceiling, but can also be used to create any object that can be modeled as a 3D box. To place a soffit, select **Build> Cabinet> Soffit** and click in any view.

By default, soffits use the material assigned to interior walls in the **Material Defaults** dialog. Like cabinets, soffits can have molding profiles applied to them.

For more information about using soffits for a variety of purposes, see “Other Objects” on page 589.

Shelves



Select **Build> Cabinet> Shelf** and click in any view to create a shelf.

Create corner shelves by placing one shelf on each wall, then moving or stretching them until they touch.

Once created, shelves can be selected and edited. See “Shelf/Partition Specification Dialog” on page 533.

You can also specify shelves inside of base, wall, and full height cabinet boxes. See “Cabinet Shelf Specification Dialog” on page 532.

Partitions



Select **Build> Cabinet> Partition** button and click in any view to create a vertical partition.

Like shelves, partitions can be selected and edited after they are placed.

Partitions can be used with shelves to create complex storage systems.

Custom Countertops



Custom Countertops are drawn and edited just like other closed-polyline based objects. Select **Build> Cabinet> Custom Countertop**, then either click and drag a rectangle or single-click to place a 2'x2' countertop. See “Custom Countertops” on page 513. You can also generate a custom countertop over one or more base cabinets

using the **Generate Custom Countertop**  edit tool. See “Using the Edit Tools” on page 517.

Cabinets Library



In the Library Browser, browse to Home Designer Core Catalogs> Architectural> Cabinets to access a selection of specialty cabinets. Select the library object you want, then click in any view to place it in the plan. Once placed, library cabinets can be edited. See “The Library” on page 603.

Cabinet Doors, Drawers, & Panels Library



A selection of special cabinet doors, drawers and panels is available in Home Designer Core Catalogs> Architectural. Select an item, then click on a cabinet in your plan to place the door or drawer onto that cabinet. Doors, drawers and panels can be assigned to a cabinet in its specification dialog, as well. Cabinet doors, drawers and panels can also be placed as stand-alone fixtures.

Built-In Appliances

A variety of fixtures and appliances such as sinks, cooktops, and dishwashers can be placed into cabinets. See “Inserted Objects” on page 621.



Place fixtures and appliances into cabinets early, so that any resizing can be done while there is adequate free space.

To insert a fixture into a cabinet, select the fixture in the Library Browser, then click on a cabinet. There must be enough space in the cabinet or adjoining cabinets to contain the selected fixture.

If a sink or cooktop is inserted into a cabinet with a top Drawer or Double Drawer, its Item Type will automatically change to a False Drawer or False Double Drawer.

Once placed, an inserted fixture can be selected and edited:

- To select a fixture in a cabinet top, click on it and then click the **Select Next**  edit button. See “Select Next Object” on page 126.
- Front fixtures can only be modified or deleted in the **Cabinet Specification** dialog. See “Front Tab” on page 526.



Fixtures can be added to both the top and front of the same cabinet. It is up to you to determine which can be effectively and safely combined in the real world.

Electrical Switches & Outlets

Electrical switches and outlets placed within the backsplash area of a base cabinet will display in front of the backsplash in 3D views when the “Electrical” layer is turned. See “The Electrical Tools” on page 487.

Cabinet Fillers

By default, Home Designer Pro models a continuous countertop and generates fillers automatically when cabinets of the same height are either touching or placed with 3” (30 mm) of one another.

If two cabinets meeting at a corner are separated from each other by 3” (30 mm) or less, the program will automatically generate a filler in the angle between them. A filler is used to separate the front of one of these cabinets from the one it meets so that drawers and doors have room to operate.

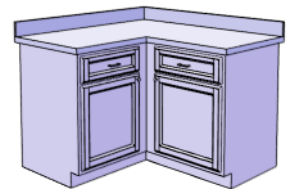
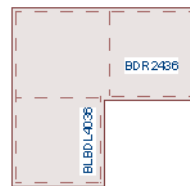

Two base cabinets and the filler between them

Placing Cabinets

Cabinets are easily created with a single click in any view. See “Click-to-Create” on page 113.

When used near a wall corner, the Cabinet Tools will produce corner cabinets and soffits. See “Corner Cabinets” on page 520.

When created, cabinets are positioned relative to the floor of the room in which they are placed. Base and full height cabinets typically rest on the floor while wall cabinets are placed a set distance above the floor. See “Cabinet Defaults” on page 507.

If the ceiling height of the room does not accommodate the height of a cabinet, its **Floor to Bottom** value will be retained and its **Height** will be reduced so that it fits under the ceiling. When this happens, some front items may be removed from the cabinet if there is not enough room for them. See “Front Tab” on page 526.

Because cabinets are typically organized into groups with shared attributes, they have some special behaviors.

Cabinet Snapping and Aligning

Cabinets have several special snapping and aligning behaviors which help you create precisely aligned cabinets quickly and easily.

- When Base and/or Full Height cabinets are within 3” of one another’s sides, they will snap together. Wall cabinets snap in a similar manner, but only with other Wall cabinets.
- When Base and/or Full Height cabinets are within 3” of one another’s sides and their front or back surfaces are within 3”

of aligning, they will become aligned. Wall cabinets snap in a similar manner with other Wall cabinets as well as Full Height cabinets.

- When a Base and/or Full Height cabinet is placed against the back of another Base or Full Height cabinet, its back surface will automatically face the other cabinet’s back. Wall cabinets snap in a similar manner with other Wall as well as Full Height cabinets.
- When a cabinet or cabinet filler is placed against a wall, its back and/or side will snap to the wall and, if the wall is moved, the cabinet will move with it.

When cabinets are snapped to a wall or to other cabinets, only exposed end cabinets have side counter overhangs.

Cabinet snapping and aligning occurs even when when **Object Snaps**  are turned off; however, you can override this behavior by moving a cabinet into the desired position using dimensions. See “Moving Objects Using Dimensions” on page 737.

Cabinet Merging

When cabinets of the same height and type are placed side-by-side within 3” (30 mm) of one another they will automatically merge, making any shared components such as the toe kick, countertop, backsplash and moldings continuous. Any gap between merged cabinets will be automatically filled.

The exposed ends of merged cabinets have side counter overhangs.

Cabinets placed at different angles will also merge if they face toward one another and meet at a front corner. Cabinets that meet at a back corner will also merge provided that they face away from one another at an angle no greater than 87°. In either case, a filler is created in the angle between the two.

If the side of a cabinet is placed within 3” (30 mm) of a wall, the countertop will extend to the wall and a filler will be created.

Cabinet merging occurs even when **Object Snaps**  are turned off.

Base and Wall Cabinets

Base and wall cabinets have different default heights, so they can be placed directly above or below one another without interference.

You can use **Object Snaps**  to center a wall cabinet’s back center point above that of

a base cabinet, or vice versa. See “Click-to-Create” on page 113.

Minimum Cabinet Size

If you try to place a cabinet into a space that is too narrow for its default size, the program will place a smaller cabinet with a width that is a multiple of the default **Resize**

Increment. For example, if you try to place a 24” wide cabinet in a 20” wide space and your **Resize Increment** is 3”, the program places an 18” cabinet. See “General Cabinet Defaults” on page 508.

If you try to place a cabinet into a space narrower than the default **Minimum Cabinet Width**, a cabinet will not be placed. If, for example, you have a space that is 8” and your **Minimum Cabinet Width** is 9”, no cabinet is placed.

Custom Countertops



Countertops are automatically generated on top of base cabinets. These default countertops are basically components of the cabinets. They can be edited in the **Cabinet Specification** dialog but cannot be selected and modified separately. You can instead use **Custom Countertops**, which are drawn and edited just like other closed-polyline based objects can be selected and edited independent of the cabinets beneath. See “Rectangular Polyline” on page 794.

Select **Build> Cabinet> Custom**

Countertop , then either click and drag a rectangle or single-click to place a 2’x2’

countertop. Custom Countertops can be drawn in any view except cross section/ elevation views.

You can also generate a custom countertop over one or more selected base cabinets by clicking the **Generate Custom Countertop**



edit button. See “Using the Edit Tools” on page 517.

When a Custom Countertop covers any portion of a base cabinet, it overrides the default countertop.

A custom countertop bases its thickness and height on the base cabinet(s) below.

- If there are multiple cabinets below, it uses the specifications for the cabinet with the greatest overall height.
- If there is no base cabinet below, its height and thickness are based on the base cabinet defaults. See “Cabinet Defaults” on page 507.

The countertop initially uses the default countertop material set in the Base Cabinet

Defaults dialog. You can specify a different material as well as the height and position in the **Custom Countertop Specification** dialog. See “Custom Countertop Specification Dialog” on page 535.

Once created, a custom countertop can be edited like other closed-polyline based objects. See “Editing Closed-Polyline Based Objects” on page 138.

Displaying Cabinets



The display of the various cabinet object types, labels, module lines, door opening indicators and more is controlled in the **Layer Display Options** dialog. See “Displaying Objects” on page 102.

In Floor Plan View

Cabinets are drawn so that wall cabinets, soffits and shelves are always in front of base and full height cabinets, countertops and partitions. You can select a cabinet of any type, though, and click the **Move to Front**



edit button to make that object display in front of other cabinets of the same type. See “Move to Front of Group” on page 151.

If the “Cabinets, Labels” layer is turned on, cabinets will display labels centered on the cabinet they represent. See “Cabinet Labels” on page 515.

Fill Styles and colors can be assigned to cabinet objects. Custom Countertops use a transparent fill style by default. If generated using the **Generate Custom Countertop**  edit tool, a Custom Countertop uses the same

fill style as the selected cabinet. See “Fill Style Tab” on page 792.

Countertops display if the “Cabinets, Countertops” layer is turned on. Custom Countertops can be assigned a molding profile, and can display the width of this profile if **Display Molding Edges** is selected in the **Custom Countertop Specification** dialog. See “General Tab” on page 535.

By default, cabinet module lines display in floor plan view when cabinet objects of the same type are placed side by side. If you prefer that these lines not display, turn off the “Cabinets, Module Lines” layer. You can also specify whether module lines are full or partial. See “General Cabinet Defaults” on page 508.

You can also display cabinet front indicator arrows in floor plan view by turning on the “Cabinets, Front Indicators” layer.

In 3D Views

To show door opening indicator arrows in cross section/elevation and Orthographic views, turn on the “Opening Indicators”

layer. Opening indicators display in Vector Views only. See “Vector View” on page 711.

In the Materials List

There are a number of ways to control how, or whether, cabinets are included in the Materials List. See “Organizing Materials Lists” on page 889.

You can add and edit information about cabinet accessories and sub-accessories in its

Components dialog. See “Components Dialog” on page 901.

If a base cabinet has an under-counter appliance inserted into it, that cabinet will not be counted in the Materials List - only the countertop materials associated with it will be listed. The cabinet will also display the appliance’s label information instead of its own.

Any crown or other moldings applied to cabinets are calculated separately and listed under the “Interior Trim” category.

Cabinet Labels

Labels for cabinets display in floor plan view when the “Cabinets, Labels” layer is turned on. See “Object Labels” on page 884.

Shelves and Partitions can also display labels when the “Cabinets, Labels” layer is turned on. Unlike cabinets, their Automatic Label is blank; however, you can specify a custom label using text in their specification dialogs.

Cabinet labels use the Text Style specified for the “Cabinets, Labels” layer. See “Text Styles” on page 765.

If a base cabinet has an under-counter appliance inserted into it, that cabinet will display the appliance’s label information instead of its own on the “Cabinets, Labels” layer.

The minimum on-screen display size of object labels can be specified in the **Preferences** dialog. See “Appearance Panel” on page 61.

Automatic Labels

The format for automatic cabinet labels has four parts: Key, Code, Size, and Door Swing.

The **Key** provides basic information about the cabinet box and its use. B refers to base cabinets, W refers to wall cabinets and U refers to full height cabinets.

Together with the key, the **Code** provides additional information about the shape of the cabinet box:

Code	
	All Cabinets
LS + Key	Lazy Susan
LSD + Key	Lazy Susan Diagonal Door
DC + Key	Diagonal Door
LC + Key	Left Corner
BC + Key	Blind Corner
Key + F	Filler
E + Key	Right or Left End
A + Key	Angled Front
PR + Key	Peninsula Radius

R + Key	Radius End
B	Base
OB	Oven Base
SB	Sink Base
RB	Range Base
#DB	Drawer Bank (# is the number of drawers)
FHB	Full Height Base (1 full height door)
W	Wall
Code from above + #D	Drawer (# is the number of drawers)
U	Full Height (Utility)
OTC	Tall Oven
RTC	Tall Refrigerator

Blind corner cabinets are dependent on the cabinet's position in the plan. A cabinet can only be a blind corner cabinet when its front is partially hidden by another cabinet. See "Blind Cabinets" on page 522. If a cabinet is moved, therefore, its Code information may change.

The **Size** follows the Code in a cabinet label. Cabinet width is always included in the label; depth and height, on the other hand, may be included depending on the cabinet type and whether they are standard or non-standard.

Base and full height cabinet labels present Size information in this order: width, depth, height. Wall cabinet labels present it in a slightly different order: width, height, depth.

	Sizes
Base	W(D)(H)
Width (W)	Always included
Depth (D)	24" (60 cm)
Height (H)	34 1/2" (90 cm)

Corner Depth (D)	Depth = Width
Wall	WH(D)
Width (W)	Always included
Height (H)	Always included
Depth (D)	12" (30 cm)
Corner Depth (D)	Depth = Width
Full Height	WDH
Width (W)	Always included
Depth (D)	Always included
Height (H)	Always included
Corner Depth (D)	Always included

Door Swing is included at the end of the label as either **L** or **R**, but only if all the doors on a cabinet have the same swing.

Here are a few examples of automatic cabinet labels and their meanings:

- **3DB24:** Base cabinet with 3 drawers, 24" wide. Depth and height are standard.
- **SB24R:** Sink base, 24" wide, with a right door. Depth and height are standard.
- **BCW2436R:** Blind wall cabinet, 24" wide, 36" high, with a right door. Depth is standard.
- **DCW2436L:** Diagonal corner wall cabinet, 24" wide, 36" high, with a left door. Depth is standard (equal to width).
- **OTC362490:** Full height cabinet with oven, 36" wide, 24" deep, 90" high.

 The Automatic Labels for Shelves and Partitions are blank, but you can specify custom labels for both. See "Shelf/Partition Specification Dialog" on page 533.

Editing Cabinets

Cabinets can be selected in 2D and 3D views both individually and in groups and edited using the edit handles, the edit toolbar and their specification dialog.

Using the Mouse

Cabinets can be edited like other box-based objects. See “Editing Box-Based Objects” on page 141. The edit handles that a cabinet displays when selected will vary depending on the view.

When a cabinet is selected in floor plan view or on its top surface in a 3D view, ten edit handles display: the Move handle at the center, the Rotate handle, and a Resize handle on each edge and at each corner.

In 3D views, cabinets can be selected on any surface: front, side, back or top. When the side of a cabinet is selected, five edit handles are available: the Move handle and a Resize handle on each edge.



When cabinet labels are displayed, a label will move as its cabinet is moved or resized. See “Displaying Cabinets” on page 514.

Cabinets cannot be concentrically resized, even when the Concentric edit behavior is enabled. See “Edit Behaviors” on page 120.

In the Specification Dialog

 A selected cabinet can be customized in a variety of ways in its specification dialog. See “Cabinet Specification Dialog” on page 522.

Multiple Cabinets

When multiple cabinets are selected as a group, any specifications that they share in common can be modified in the **Cabinet Specification** dialog.

When you group select cabinets of different types, some options are not available in the **Cabinet Specification** dialog. For example, you cannot modify the crown molding on a full height cabinet if it is selected with a base cabinet that does not have crown molding.

Soffits, shelves, and partitions can be group selected and edited using their corresponding specification dialog. It is important that only soffits, or only shelves, or only partitions be a part of the selection set in order to access the needed specification dialog.

Using the Edit Tools

A cabinet or cabinets can be edited in a variety of ways using the buttons on the edit toolbar. See “The Edit Toolbar” on page 29.

Using Dimensions

 Like various other objects, cabinets can be moved and resized using dimensions. See “Moving Objects Using Dimensions” on page 737.

In order to be edited using dimensions, cabinets must be located by them. You can specify whether cabinets are located by dimensions in the **Dimension Defaults** dialog. See “Locate Objects Tab” on page 723.

Dimensions can be set to locate the sides and/or corners of cabinet boxes - not the countertop. If you wish, you can move a dimension’s extension lines to locate the countertop after the dimension is drawn. See “Editing Extension Lines” on page 735.

Temporary Dimensions will locate the wall surface nearest the selected object edge or either cabinet boxes or Custom Countertops, depending on which type of object is selected:

- If a cabinet box is selected, Temporary Dimensions will locate the nearest wall surface or another cabinet box, but not Custom or automatically generated Countertops.

- If a Custom Countertop is selected, Temporary Dimensions will locate the nearest wall surface or another Custom Countertop, but not cabinet boxes or automatically generated counters.

Moving Walls with Cabinets Attached

When a cabinet is placed or moved against a wall, it will snap to the wall and become attached to it. When a wall is moved, all attached cabinets move with it.

Moving a wall to an unattached cabinet will not attach the cabinet to it: the cabinet must be moved to the wall. A cabinet can also be attached to a wall when **Plan Check**  is used. See “Plan Check” on page 801.

When wall layers are resized or the wall layer definition redefined, the cabinets may become unattached. To reattach, select them, drag them away from the wall, and then drag them back again.

Editing Cabinet Styles

A variety of settings allow you customize the appearance of your cabinets to create styles ranging from traditional to contemporary.

If the desired style is known before cabinets are placed, you can save time by specifying that style in the **Cabinet Defaults** dialogs before you start drawing. See “Cabinet Defaults” on page 507.

Cabinet Front Items

A variety of different front items can be added to any cabinet, including doors,

drawers, cutting boards, and horizontal separations. Front items can also be moved, resized, as well as removed. See “Front Tab” on page 526.

Doors, Drawers & Panels

Cabinet doors, drawers, and panels can be applied in either of two ways:

- In the **Cabinet Specification** dialog. See “Door/Drawer Tab” on page 529.
- Directly from the Library Browser.

Select a style in the library, then click on a cabinet to apply the selected style to that cabinet. In 3D views, click on a face item to apply the selected library object to that item. See “Placing Library Objects” on page 620.

A secondary door or drawer style can also be specified - for example, to create glass doors above solid doors in wall cabinets. See “Front Tab” on page 526.

Cabinet Hardware & Moldings

Cabinet handles, pulls, and hinges can be assigned in the **Cabinet Specification** dialog. See “Door/Drawer Tab” on page 529.

In 3D views, pulls and handles can also be applied directly from the Library Browser. Select a hardware item, then click on the cabinet face item to apply it to that face item.

Multiple molding profiles can also be applied around the perimeter of a cabinet at any height. For example, you may want a wood edge around base cabinet countertops and a crown molding that ties together the tops of the wall cabinets and full height cabinets. See “Moldings Tab” on page 503.



Wall cabinet with crown molding and light rail

Countertops & Backsplashes

Countertop thickness, overhang, and material for a selected base cabinet can be specified in the **Base Cabinet Specification** dialog. See “General Tab” on page 523.

Backsplashes can also be applied to base cabinets, also on the General tab of their specification dialog.

Cabinet Shelves

You can customize the shelves inside of base, wall, and full height cabinet boxes. See “Cabinet Shelf Specification Dialog” on page 532.

Editing Custom Countertops

Custom Countertops can be selected in 2D and 3D views and edited using the edit handles, the edit toolbar and their specification dialogs. See “Custom Countertop Specification Dialog” on page 535.

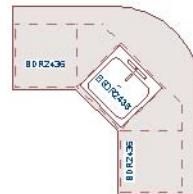

Using the Mouse

Custom countertops are considered to be CAD-based objects and are edited the way closed polylines are. See “Editing Closed-Polyline Based Objects” on page 138.

Using the Edit Toolbar

A selected Custom Countertop can be edited in a variety of ways using the buttons on the

edit toolbar. See “The Edit Toolbar” on page 29.

Countertop Edge Profiles

You can specify the edge profile of a custom countertop in the **Custom Countertop Specification** dialog. See “Moldings Tab” on page 534.

Special Cabinets

There are a number of special cabinet shapes that can be specified. Certain requirements must be met before some special cabinet shapes can be specified. If the requirements are not met, a warning message will explain what is needed. See “Cabinet Specification Dialog” on page 522.

Note: Only Standard cabinets can be the default cabinet Type. See “Cabinet Defaults” on page 507.



Standard Cabinets

Select **Build > Cabinet > Base Cabinet**  and click in floor plan view to place a standard, rectangular base cabinet.



Standard (default) cabinet

Corner Cabinets

To create a corner cabinet, click as close to an inside wall corner as possible in using either the **Base Cabinet** , **Wall Cabinet** , or **Full Height**  cabinet tool. A corner cabinet remains a corner cabinet when it is moved, edited or copied.

Turn an existing cabinet into a corner cabinet by selecting Corner Cabinet from the **Special** drop-down list in its specification dialog. See “General Tab” on page 523.

- Before a corner cabinet can be specified in the **Cabinet Specification** dialog, the cabinet’s Width must be greater than its Depth.
- The **Left** and the **Right Side Widths** can be set independently for corner cabinets.



Corner cabinet with sides of equal width

- You can specify a Diagonal Door on corner cabinets to create an angled corner cabinet. See “Front Tab” on page 526.



Corner cabinet with diagonal door

End Cabinets

Open a cabinet for specification and select Left or Right End Cabinet from the **Special** drop-down list to create an end cabinet.



Left End Cabinet

- End Cabinets have an angled front and side.
- The cabinet width must be no greater than its depth for an end cabinet to be specified.

Radius End Cabinets

Open a cabinet for specification and select Right or Left Radius End from the **Special** drop-down list to create a radius end cabinet.



Radius End cabinets have a 90° arch

As you face the cabinet, a right radius end curves to the right, and a left radius end curves to the left.

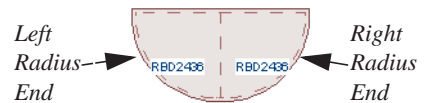

Peninsula Radius Cabinets

Open a cabinet for specification and select Pen. Radius from the **Special** drop-down list to create peninsula radius cabinet.



Peninsula Radius Cabinet

The radius can be adjusted by changing the Depth/Bow Depth value. See “General Tab” on page 523.

Angled Front Cabinets

Open a cabinet for specification and select **Angled Front** from the **Special** drop-down list to create an angled front cabinet.

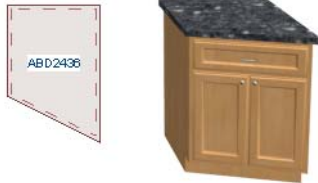

Angled Front Cabinet

- The length of the left and right side of an **Angled Front** cabinet can be defined by changing the **Depth/Bow Depth** value. See “General Tab” on page 523.

Kitchen Islands

To create a kitchen island, simply place several cabinets back-to-back and/or side-to-side. Match the widths so that each cabinet back or side meets the back or side of only one other cabinet. If this is not done, the lines separating the cabinets cannot be suppressed.

Two cabinets cannot merge with the same side of another cabinet. The picture shows two instances when cabinets are placed back-to-back. Cabinet fronts and joining surfaces are shown.

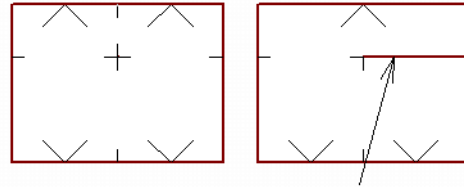

*Correct -
Widths of front and
back cabinets match*

*Incorrect -
Solid line here is not
suppressed.*

Blind Cabinets

Often, when two cabinets meet in a corner, one is partially hidden by the other. This partially hidden cabinet is called a “blind” cabinet. Home Designer Pro will resize and offset the front items of the partially hidden cabinet so that they are not located in the hidden portion of the cabinet face.



You can also create a blind cabinet manually by controlling the widths of a cabinet’s left or right stile in its **Cabinet Specification** dialog. See “Front Tab” on page 526.

Cabinet Specification Dialog



Select one or more cabinet and click the **Open Object** edit button to open the **Cabinet Specification** dialog.

The options in the **Cabinet Specification** dialogs are similar to the corresponding **Cabinet Defaults** dialog. See “Cabinet Defaults” on page 507.

General Tab

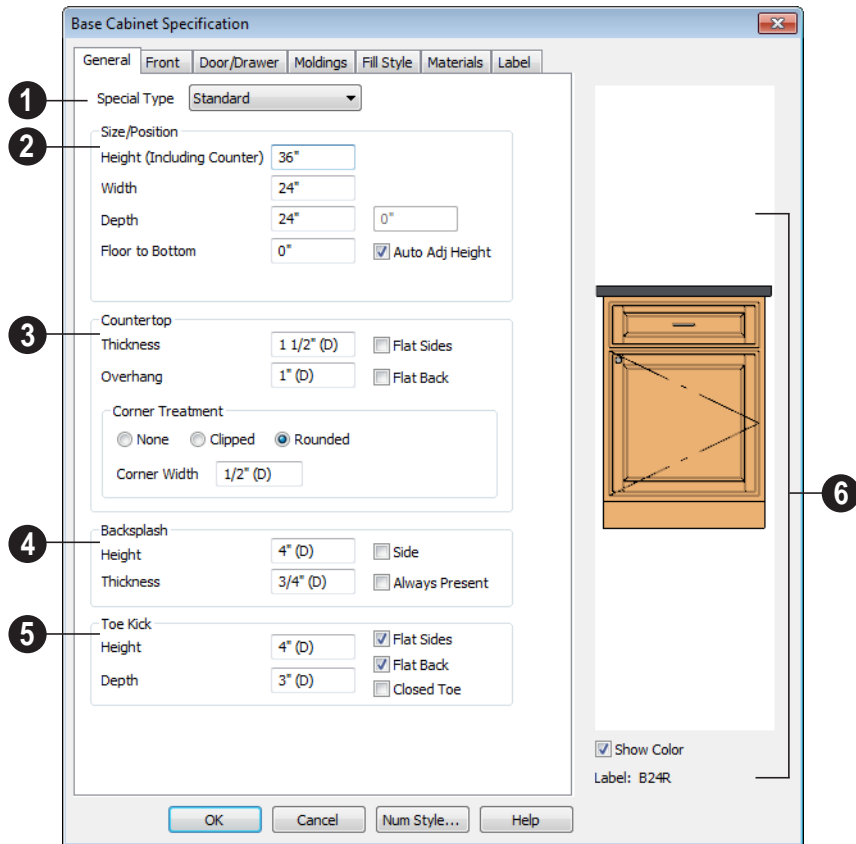

1 A number of **Special** cabinet types are available in the drop-down list. Certain requirements must be met before some special cabinet shapes can be specified. Not available in the **Cabinet Defaults** dialogs. See “Special Cabinets” on page 520.

2 **Size/Position** - The selected cabinet’s dimensions and position relative to the floor can be specified here. Fractional values are supported to 1/16th of an inch (1 mm).

- Specify the **Height (Including Counter)** of the cabinet box, as measured from bottom to top. For base cabinets, this value includes the countertop thickness, but not the height of the backsplash.

Note: Height refers to the height of the entire cabinet, including countertop and toe kick. If you change the Countertop Thickness or Toe Kick Height, the cabinet’s total height is not altered. Instead, the cabinet face height and the heights of face items change in response.

- Specify the **Width** of the cabinet box, as measured across the front of the cabinet box from left to right. This does not include the countertop overhang.
- Specify the **Depth** of the cabinet box, as measured from front to back. It does not include the thickness of overlay doors or the countertop overhang.
- For corner cabinets, the **Width** and **Depth** fields become **Right Side Width** and **Left Side Width**. If a corner cabinet is assigned a diagonal door on the Front tab, the second **Right Side Width** field specifies the bow depth: a positive number creates a bow and a negative number, an inside bow.
- Specify the **Floor to Bottom** distance. For base and full height cabinets, this is usually 0.
- When the selected cabinet is outside a room and **Auto Adjust Height** is checked, its Floor to Bottom height is measured relative to the terrain height. When this is unchecked, the Floor to Bottom height is measured from the default floor height of Floor 1. See “Terrain Height vs Floor Height” on page 539 of the Reference Manual.

3 Specify the dimensions and style of the **Countertop** here. Only available for base cabinets.

- Specify the countertop **Thickness**. Changing this value does not alter the cabinet height, but it does affect the height of face items. See “Front Tab” on page 526.
- Specify the countertop **Overhang**. The Overhang is used for any side of a cabinet not against a wall or another cabinet.

- Check **Flat Sides** to eliminate the counter overhang on the cabinet’s exposed ends.
- Check **Flat Back** to eliminate the overhang on cabinets with an exposed back.
- **Countertop Corner Treatment** - Specify clipped or rounded countertop corners.

4 The dimensions and style of the **Backsplash** are specified here. The backsplash only displays when the cabinet is against a wall. Only available for base and wall cabinets.

- Specify the backsplash **Height** and **Thickness**. Height is only available for base cabinets - not wall cabinets.
- Check **Side** to add the same height backsplash on the side of the cabinet if it is against a wall or a taller cabinet.
- Check **Always Present** to display the backsplash at all times. If unchecked, a backsplash is present only when the cabinet is against a wall.
- Check **Backsplash to Base Below** to extend a backsplash from the selected wall cabinet down to the backsplash or countertop of the base cabinet below. Only available for wall cabinets.

The backsplash for a base cabinet is measured from the countertop up. The backsplash for a wall cabinet extends from the bottom of the cabinet down to the base cabinet or its backsplash.

5 **Toe Kick** - The dimensions and style of the toe kick are specified here. Only available for base and full height cabinets.

- Specify the **Toe Kick Height** and **Depth** values for base or full height cabinets. Changing the Toe Kick Height does not

alter the cabinet height but does affect the heights of the cabinet face and face items.

If the Toe Kick Height or Depth is set to use the default “(D),” the toe kick is only generated when the Floor to Bottom height is 0. Delete the “(D)” and enter a positive value to display a toe kick on a cabinet that is raised off the floor.

- **Flat Sides** can be added to base and full height cabinets. Checking Flat Sides eliminates the toe kick area on the exposed end(s) of the cabinet.
- Check **Flat Back** to eliminate the toe kick on a cabinet with an exposed back.

This does not eliminate the toe kick on the cabinet front.

- Check **Closed Toe** to extend the cabinet sides to cover the sides of the toe kick area. If pilasters that do not extend to the floor are specified, checking this places a support block under them at exposed corners.
- 6 The preview of the cabinet updates as the cabinet changes.
- Uncheck **Show Color** to show the cabinet preview in black and white.
- The **Cabinet Label** displays below the preview diagram. See “Cabinet Labels” on page 515.

Front Tab

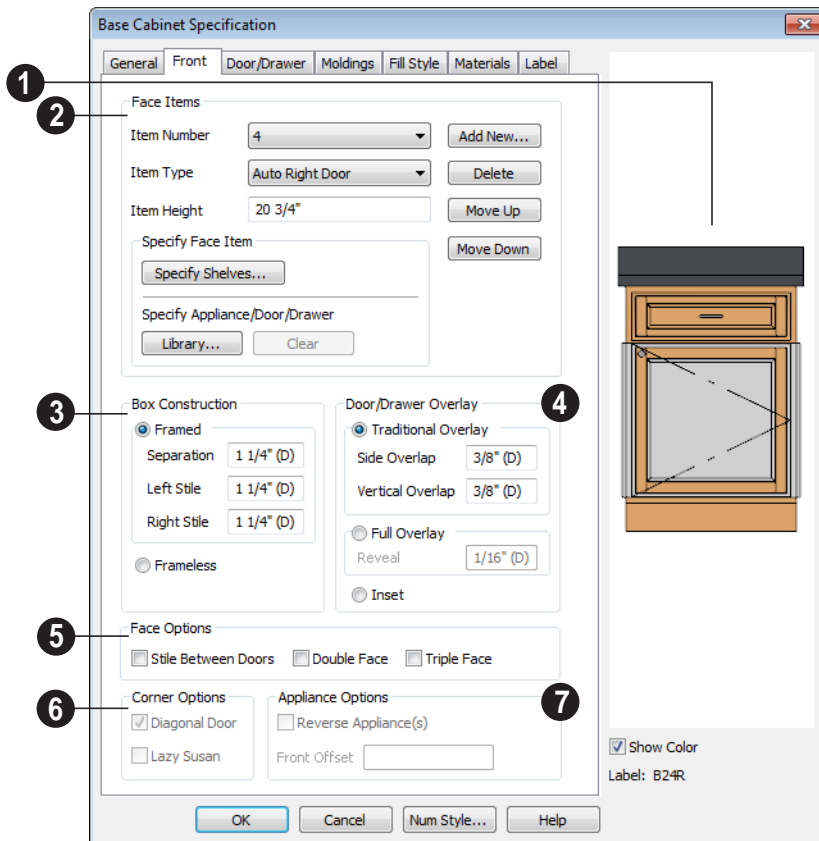

1 Click on a face item in the preview diagram to select it. The selected item is highlighted, and the **Face Items** settings below become active, allowing you to edit the selected item.

Face items are usually separated by a frame piece known as a rail or **Separation**. The frame pieces on the sides are referred to as stiles and cannot be selected in the preview.

2 Define the **Face Items** on the front of the selected cabinet. For best results,

edit face items starting at the top of the cabinet and work down.

The **Item Number** of the selected face item displays here. Click the drop-down list to select a different item. Item numbers start at the top of the cabinet and go down the face. Item Number 1 is usually the top face frame rail (separation).

Click the **Item Type** drop-down list to apply a type to the selected Face Item, such as a door, drawers or panel.

- Cabinet fronts may be composed of any combination of face items, but there is a limit to the number of items that can reasonably fit on a given cabinet's front.
- Auto Right and Auto Left Doors become double doors automatically when the cabinet width is greater than 24" (600 mm). Left, Right and Double Doors are as specified regardless of the cabinet width.
- False Drawers assume the appearance of the drawer style and hardware assigned to the cabinet.
- Door Panels assume the appearance of the cabinet's door style but without door hardware.
- The backsplash can be selected but its Type cannot be changed.

Item Height - Define a value for the selected item in the cabinet front. Fractional heights are supported to 1/16th of an inch (1 mm).

- When the height of a cabinet is changed, or the height of a face item is changed, the height of the lowest face item is altered to make up the difference.
- If you modify the lowest item, the item directly above is adjusted. Set the countertop height and the toe kick height first, and then work from the top to the bottom when adjusting face items.
- If the height of an appliance has been altered, entering "d" restores its default height.

Note: To ensure that Face Item heights always equal the total cabinet front height, the program automatically adjusts the bottom Face Item as changes are made elsewhere. This means you should start editing Face Items at the top and work down.

Click **Specify Shelves** to open the **Cabinet Shelves Specification** dialog and specify the shelf configuration for a selected Door or Opening Face Item. See "Cabinet Shelf Specification Dialog" on page 532.

Specify Appliance/Door/Drawer - Click the **Library** button to choose an appliance, door style, or drawer style for the selected Face Item from the library. See "Select Library Object Dialog" on page 622.

- If "Appliance" is the selected Item Type, you can specify an appliance. See "Built-In Appliances" on page 511.
- If a Door or Drawer Item Type is selected, you can specify a secondary door or drawer style. See "Doors, Drawers & Panels" on page 518.
- Click the **Clear** button to remove the library appliance, door, or drawer from the selected Face Item.

Click **Add New** to add a new face item directly below the currently selected item.

- When you click **Add New**, the **New Cabinet Face Item** dialog displays. Define the **Item Type**, **Item Height** and click OK.

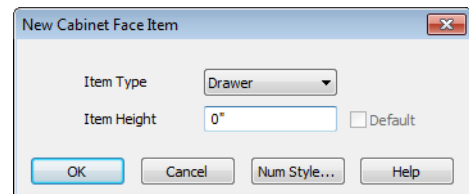

- If you click **Add New** with no face item selected, the program adds the new item at the bottom of the cabinet face.
- When a face item is added to the cabinet front, the program attempts to reduce the

height of the lowest item on the cabinet front to make room for the new item.

Click **Delete** to remove the currently selected item.

- When a face item is deleted, the height of the lowest item is usually increased to make up the difference.
- When an Auto Left, Auto Right, Left, Right, or Double Door is deleted, it is replaced by an Opening.

Click **Move Up** to move the currently selected item up one position, switching places with the item directly above.

Click **Move Down** to move the currently selected item down one position, switching places with the item directly below.

Note: The program tries to maintain a single separation between all face items. When you add or delete a face item, separations are usually added or deleted with them.

3 Define the **Box Construction** of the selected cabinet. Select **Framed** to create a traditional framed cabinet and enable the settings below, or choose **Frameless** for a European style cabinet.

- Specify the **Separation** value, which is the width of the horizontal face frame piece between doors, drawers, and face items.
- Specify the widths of the **Left** and **Right Stile**, which are the vertical frame pieces to the left and right of all face items.

When set to default (D), the program uses the default Separation value for the left and right stile widths.

4 Define the **Door/Drawer Overlay** of the selected cabinet.

- Select **Traditional Overlay**, then specify the **Side** and **Vertical Overlay** values.

The **Side Overlay** is the distance that doors and drawers overlap the vertical stiles of the cabinet box and is applied to both sides of the doors and drawers.

The **Vertical Overlay** is the distance that doors and drawers overlap the horizontal separations between front items and is applied to both the top and bottom of the doors and drawers.

- Select **Full Overlay**, then specify the **Reveal**, which is the distance between door and drawer front items.
- Select **Inset** to produce doors and drawers that are flush with the rails and stiles rather than overlaying it.

5 **Face Options**

- Check **Stile Between Doors** to have double doors and double drawers separated by a stile. This has no effect on other item types.
- Check **Double Face** to replace the cabinet's face items with two faces, each approximately half as wide.
- Check **Triple Face** to replace the cabinet face items with three faces.

6 The **Corner Options** are available when the selected cabinet is specified as a Corner Cabinet Type. See "Corner Cabinets" on page 520.

- Uncheck **Diagonal Door** to create double doors at right angles instead of a single

diagonal door. This option is checked by default in the **Cabinet Defaults** dialog.

- Check **Lazy Susan** to indicate a lazy Susan in the cabinet's label and its appearance in floor plan view. This option does not display in 3D views.

7 The **Appliance Options** are available when the selected cabinet has an appliance inserted into it. See “Inserted Objects” on page 621.

- Select **Reverse Appliance** to reverse the fixture from left to right: for example, to change a left hand door on a built-in refrigerator to a right hand door.
- Specify the **Front Offset**, which is the distance from the front of a top-mounted appliance to the counter edge. Only available for base cabinets with a top-mounted fixture, such as a sink or cooktop.

Door/Drawer Tab

The settings on the Door/Drawer tab allow you to control the appearance of the selected cabinet's doors, drawers, and hardware.

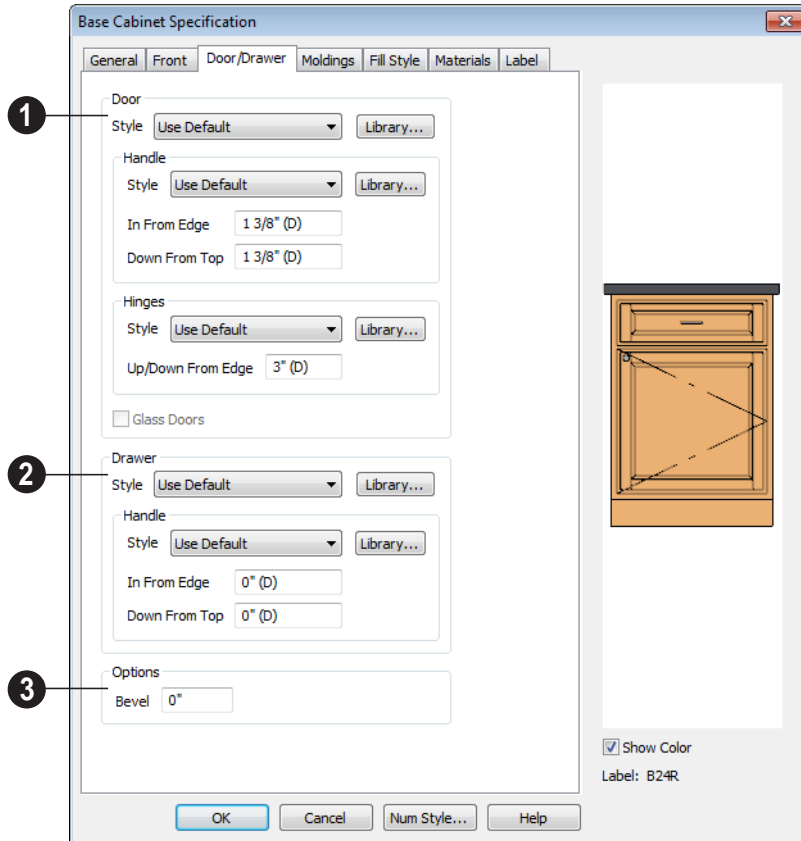

1 Specify the style and hardware for any **Doors** applied to selected cabinet(s).

Select a door **Style** from the drop-down list. See “Doors, Drawers & Panels” on page 518.

- Select “Use Default” to apply the door style specified in the defaults dialog for the selected cabinet’s type. See “Cabinet Defaults” on page 507.
- Select “Slab Doors” to apply a flat door front or “Framed Doors” to apply a door with a frame and flat panel front.

- Select “Library” or click the **Library** button to select a cabinet door from the library. If a library door has been previously selected, its name will display in the list. See “Select Library Object Dialog” on page 622.

Specify the characteristics of the cabinet’s door **Handles**.

- Select a door handle **Style** from the drop-down list or choose one from the library.

- Specify the position of the handle **In From Edge**, as measured from the edge of the door opposite the hinges.
- Specify the height of the handle **Down From Top**, as measured from the top edge of the door. For wall cabinets, this value is measured **Up From Bottom**.

Specify the characteristics of the cabinet door **Hinges**.

- Select a door hinge **Style** from the drop-down list or choose one from the library.
- Specify the location of the hinges **Up/Down From Edge**, as measured from the door edge. If the cabinet door is more than 35 1/4" (880 mm) high, three hinges will be created instead of two.

Glass Doors is available for cabinets with Slab or Framed doors. Framed door panels are created using a glass material. The entire door is glass on Slab doors.

- 2** Specify the style and hardware for any **Drawers** applied to the cabinet(s).

Select a **Drawer Style** from the drop-down list or choose one from the library. For best results, Framed drawers should be at least 6" (150 mm) high.

Select a drawer **Handle Style** from the drop-down list or choose one from the library.

- The **In From Drawer Edge** setting creates two handles the specified distance from the left and right drawer edges. A value of 0 creates a single handle centered horizontally on the drawer.
- Specify the location of the handle **Down From Top**. A value of 0 centers the handle vertically on the drawer.

3 Options

- Enter a **Bevel** width value to create beveled edges on Slab drawers and doors. This does not affect Framed or Library doors. The bevel width, as viewed from the front, has a maximum value of 3" (75 mm).

Moldings Tab

The settings on the Moldings tab allow you to assign one or more horizontal moldings around the selected cabinet. See "Editing Cabinet Styles" on page 518.

For information about the settings on this tab, see "Moldings Tab" on page 503.

Fill Style Tab

The settings on the Fill Style tab affect the appearance of the selected cabinet in floor plan view. For more information, see "Fill Style Tab" on page 792.

Materials Tab

The settings on the Materials tab affect the appearance of the selected cabinet in 3D views. For information about these settings, see "Materials Tab" on page 635.

Some material options may be disabled if the selected cabinet is a manufacturer symbol.

Label Tab

Cabinet labels display in floor plan view when the "Cabinets, Labels" layer is turned on and use the Text Style assigned to that layer. See "Cabinet Labels" on page 515.

For more information about the settings on this tab, see “Label Tab” on page 885.

Cabinet Shelf Specification Dialog

From the Front tab of the **Base Cabinet**, **Wall Cabinet**, or **Full Height Cabinet Specification** dialog, select a door or opening face item in the preview diagram

and click the **Specify Shelves** button to open the **Cabinet Shelf Specification** dialog. See “Front Tab” on page 526.

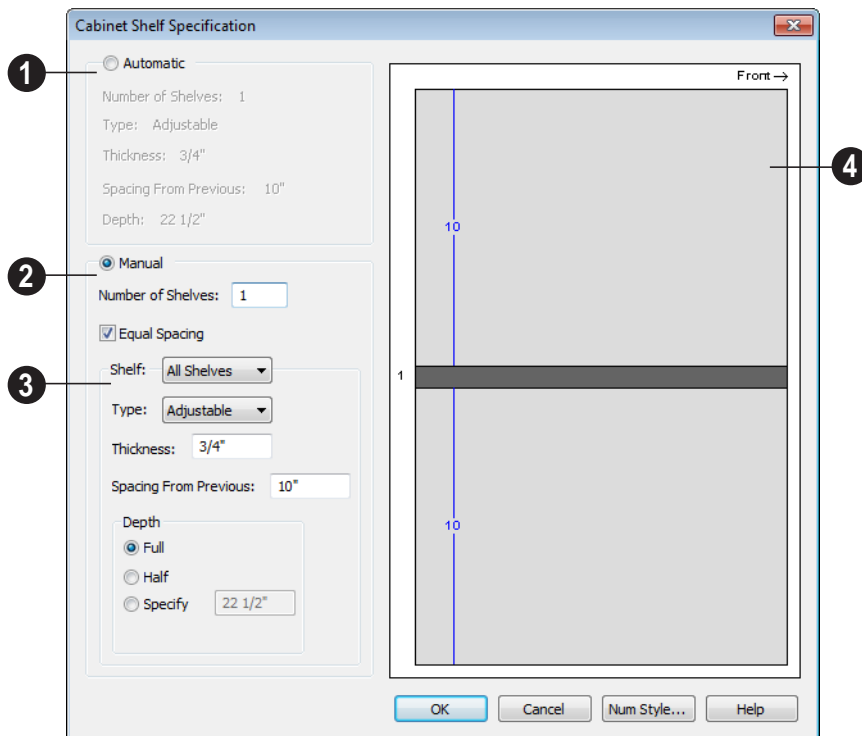

Automatic

1 By default, cabinet shelves are specified automatically. The default number of shelves, shelf type, thickness, spacing, and depth display here.

Manual

2 Select the **Manual** radio button to specify cabinet shelving for the selected door or opening. If a cabinet is resized after shelving has been manually edited, the

specifications are maintained, but all shelves may not be display in all situations.

The **Number of Shelves** can be specified. **Equal Spacing** is checked by default.

3 The shelf type, thickness, spacing, and depth can be specified on a per shelf basis or for all shelves at once. To determine which, select the shelf number or **All Shelves** from the drop-down list.

Note: If All Shelves is selected after changes have been made to any one shelf, “no change” displays, indicating that all shelves are not the same.

- Specify the shelf **Type** from the drop-down list.
- Enter a shelf **Thickness** in fractions or decimals.
- Changing the **Spacing From Previous** unchecks **Equal Spacing** above.
- You can select Full, Half or Specify the shelf **Depth** manually.
- 4** The preview shows shelf numbers, thickness, depth, and spacing. Press the Tab key to update the preview as changes are made.

Shelf/Partition Specification Dialog



Select a shelf or partition and click the **Open Object** edit button to open the **Shelf Specification** or **Partition Specification** dialog.

The options in these specification dialogs are similar to the corresponding defaults dialogs. See “Cabinet Defaults” on page 507.

General Tab

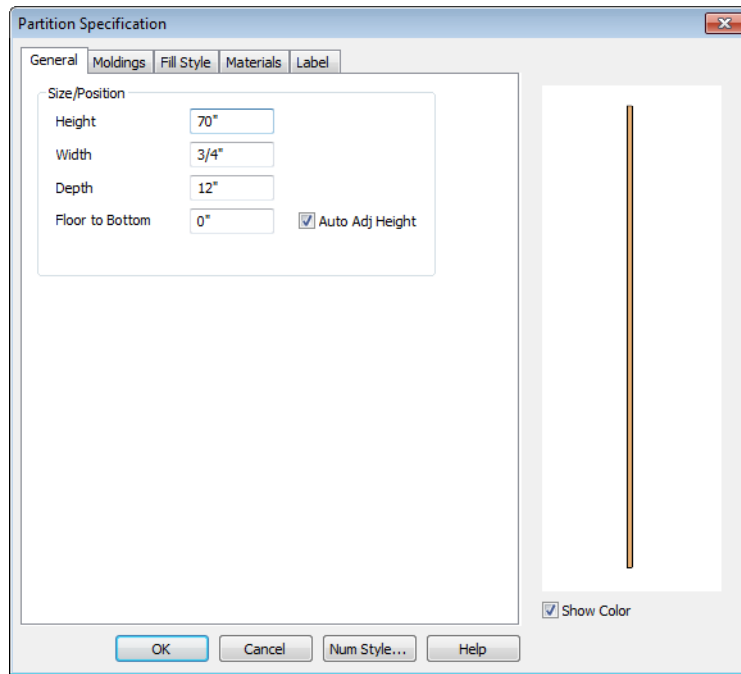

Specify the **Height**, **Width**, **Depth**, and the distance from the **Floor to Bottom** of the shelf or partition.

When the selected object is outside a room and **Auto Adjust Height** is checked, its Floor to Bottom height is measured relative to the terrain height. When this is unchecked, the Floor to Bottom height is measured from the default floor height of Floor 1. See “Terrain Height vs Floor Height” on page 539 of the Reference Manual.

Fill Style Tab

The settings on the Fill Style tab affect the appearance of the selected object in floor

plan view. For information about these settings, see “Fill Style Tab” on page 792.

Moldings Tab

The settings on the Moldings tab allow you to apply molding to the selected object. For information about these settings, see “Moldings Tab” on page 531.

Materials Tab

The settings on the Materials tab affect the appearance of the selected object in 3D views. For information about these settings, see “Materials Tab” on page 635.

Label Tab

Shelf and Partition labels display in floor plan view when the “Cabinets, Labels” layer is turned on and use the Text Style assigned to that layer. The Automatic Labels for

Shelves and Partitions are blank, but you can specify custom labels. See “Cabinet Labels” on page 515.

For more information about the settings on this tab, see “Label Tab” on page 885.

Custom Countertop Specification Dialog



Select a custom countertop and click the **Open Object** edit button to open the **Custom Countertop Specification** dialog.

- Specify the **Thickness** of the countertop independent of the cabinet below. **Set Thickness From Cabinet** must be unchecked.
- Check **No Molding on Selected Edge** to turn off molding on the selected edge.

General Tab

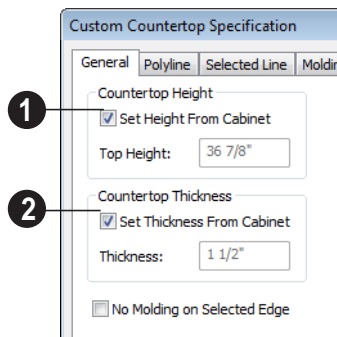

- 1 Uncheck **Set Height From Cabinet** to specify Height of the selected countertop. When checked, the Countertop Height is determined by the cabinet below.
 - **Top Height** - Specify the height of the top of the custom countertop independent of the cabinet below. **Set Height From Cabinet** must be unchecked.
- 2 Uncheck **Set Thickness From Cabinet** to specify the thickness of the selected countertop. When checked, the Countertop Thickness is determined by the cabinet below.

Polyline Tab

The Polyline tab state’s the length of the countertop’s **Length/Perimeter**, its **Area**, and its **Volume**.

Selected Line/Arc Tab

The Selected Line tab is available when the selected edge is a line as opposed to an arc. For more information, see “Line Tab” on page 780.

The Selected Arc tab is available when the selected edge has been converted to an arc. For more information, see “Arc Tab” on page 787.

Moldings Tab

The settings on the Moldings tab allow you to apply an edge profile to the selected countertop. For information about these settings, see “Moldings Tab” on page 531.

Line Style Tab

For information about the settings on this tab, see “Line Style Tab” on page 781.

Fill Style Tab

The settings on the Fill Style tab affect the appearance of the selected countertop in floor plan view. For information about these settings, see “Fill Style Tab” on page 792.

Materials Tab

The settings on the Materials tab affect the appearance of the selected countertop in 3D views. For information about these settings, see “Materials Tab” on page 635.

Terrain

Home Designer Pro allows you to model the terrain around a house. Begin by specifying elevation data that creates the surface contours, and then add surface features such as planting areas, water features and plants.

You can import terrain data from a variety of sources and use this data to produce your 3D model.

Once the terrain is modeled, shadows that follow the terrain can be created using the Sun Angle tool. See “Sun Angles” on page 701.

Roads and sidewalks are among the objects that can be placed in your terrain and are discussed in “Roads, Driveways & Sidewalks” on page 583.











Chapter Contents

- Terrain Toolbar Configuration
- Terrain Perimeter
- Elevation Data Tools
- Terrain Modifier Tools
- Terrain Feature Tools
- Garden Bed Tools
- Water Feature Tools
- Stepping Stone Tools
- Terrain Wall and Curb Tools
- Sun Shadows
- Terrain Objects in the Library
- Displaying Terrain
- Editing Terrain Objects
- Terrain Object Specification Dialogs
- Importing Elevation Data
- Converting CAD Lines to Terrain Data
- Plant Tools
- Plant Image Specification Dialog
- Plant Chooser Dialog
- Hardiness Zones
- Sprinkler Tools
- Sprinkler Specification Dialog

Terrain Toolbar Configuration

 The Terrain and Road Tools can be accessed through the Terrain menu. You can also display these tools on your toolbar using the **Terrain Configuration**. See “Toolbar Configurations” on page 98.

The Terrain Configuration and Terrain menu both display the following terrain and road parent tools:

- **Elevation Data Tools**  allow you to add elevation data to your terrain.
- **Terrain Modifier Tools**  model changes in elevation within a defined area.
- **Terrain Feature Tools**  let you add materials over the top of the terrain.
- **Garden Bed Tools**  create Terrain Features with a mulch material.
- **Water Feature Tools**  create Terrain Features with a water material.
- **Stepping Stone Tools**  are used to create paths composed of multiple Terrain Features.
- **Terrain Wall and Curb Tools**  let you draw walls and curbs that follow the terrain.
- **Road, Driveway and Sidewalk Tools**  allow you to create paved areas that can form intersections.
- **Plant Tools**  allow you to place plant images and 3D plant symbols.
- **Sprinkler Tools**  are used to lay out sprinkler symbols and irrigation lines.

Terrain Perimeter

 The Terrain Perimeter is a closed polyline defining the boundary of the terrain that generates in 3D views and of the contour lines that generate in floor plan view. A Terrain Perimeter should be present in your plan already, but if one is not, select **Terrain > Create Terrain Perimeter** to create one.

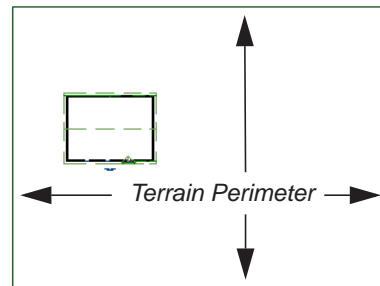

If you create a terrain perimeter in floor plan view but do not see it, select **Window > Fill**

Window . See “Zoom Tools” on page 654.

When created in a new, blank plan, a new terrain perimeter will be 50' x 100'. If you create a terrain perimeter after you have drawn all or part of a 3D model, it may increase in size as needed to encompass everything in floor plan view.

Once created, the terrain perimeter can be resized and edited like other polyline-based objects. See “Editing Closed-Polyline Based Objects” on page 138.

When a terrain perimeter is first created, it is completely flat and is placed at a height of 0'-0", or sea level.



Terrain perimeter at 0' - 0" in a 3D view

The terrain perimeter by itself does not have elevation data associated with it. You can use the **Elevation Data**  and **Terrain**

Modifier  tools to create terrain that slopes in a wide variety of ways. If you do not create elevation data within the terrain perimeter, the terrain remains flat at an elevation of 0' - 0". See “Elevation Data Tools” on page 540 and “Terrain Modifier Tools” on page 545.

Terrain Height vs Floor Height

Home Designer Pro always defines the default height of Floor 1 at 0'-0". This height

value is the constant by which the heights of architectural objects and structural elements in the program, including walls, floors, and ceilings, are measured.

The default height of Floor 1 is not, however, the absolute by which terrain elevation is measured. Instead, elevation data is measured relative to sea level. This means that if you want to, you can use real-world elevation data to generate a 3D terrain model without also having to measure floor and ceiling heights from sea level. See “Importing Elevation Data” on page 567.

The program automatically positions Floor 1 a set distance above the terrain. To do this, it first finds the center point of the building footprint. Then, it determines the elevation of the terrain at that point. Finally, it adds 6" (150 mm) plus the thickness of the floor platform and treated sill plate to this value. The resulting value, referred to as the Building Pad Elevation, is how far the default height of Floor 1 is above sea level in the current plan. See “Foundations and the Terrain” on page 339.

In a plan with a foundation present, the Elevation distance will equal the exact terrain elevation at the building footprint center point, plus 6" (150 mm), plus the thickness of the floor platform.

- In a plan with no elevation data, the terrain is assumed to be at sea level and this Elevation distance is 6" (150 mm) plus the thickness of the floor platform when a foundation is present.
- In a plan with flat terrain at 100' (30 m) and a foundation present, the Elevation distance is 100' 6" (30.468 m) plus the thickness of the floor platform.

Once terrain has been built, the Elevation distance is stated in the **Terrain Specification** dialog. You can specify a custom Elevation value to produce a daylight or walkout basement. See “General Tab” on page 554.

Note: When no foundation has been built, the distance from Floor 1 to the terrain is 12” (320 mm).

Build Terrain



Select **Terrain > Build Terrain** to generate the terrain surface based on the provided elevation data. Build Terrain also updates the Building Pad Elevation value in the **Terrain Specification** dialog. See “Building the Terrain” on page 552.

Clear Terrain



To remove the generated terrain contours, select **Terrain > Clear Terrain**. When the terrain is cleared, contours do not display in 3D and contour lines do not display in floor plan view.

Clear Terrain  does not remove the terrain perimeter, elevation data, or terrain features from the model. Rather it deletes all program-generated 2D contour lines and 3D contours.

The Terrain Perimeter has a variety of editable properties, including many that

affect the appearance of the terrain in 2D and 3D views. See “Terrain Specification Dialog” on page 554.

Terrain Surface Triangles

Home Designer Pro generates 3D terrain surfaces by dividing them into triangles. The size of the triangles determines how detailed contour lines and terrain surfaces in the 3D model can be. You can specify triangle size in the **Terrain Perimeter Specification** dialog. See “General Tab” on page 554.

Increasing the triangle count decreases triangle size, yielding more detailed contour lines and a better 3D approximation of the terrain. Smaller triangles demand longer terrain generation time and increased memory requirements. If you select a large number of small triangles for a large site, you may wait a long time for the calculation.

Decreasing the triangle count increases triangle size. Elevation lines are sampled less frequently, speeding up terrain generation. If you specify a small number of triangles for a plan with detailed elevation data, contour lines and 3D surfaces may not generate correctly.



When a large terrain perimeter is used, consider increasing the Triangle Count to help make sure all Elevation Data and Terrain Modifiers generate contours.





Elevation Data Tools



Select **Terrain > Elevation Data** to add elevation information to your terrain.

When terrain is generated, this data is used to calculate the surface of your site and is represented by contour lines in floor plan

view and a curved surface in 3D. See “Displaying Terrain” on page 551.

Elevation data can be specified using the **Elevation Point** , **Elevation Line** , **Elevation Spline** , **Elevation Region**  and **Terrain Break**  tools.

Elevation data can also be imported. See “Importing Elevation Data” on page 567.

The elevation of each Elevation Line, Spline and Region is specified relative to sea level.

In order to create rising and/or falling terrain, multiple terrain data objects with different elevation values must be used. If only one terrain data object is placed, the terrain will be flat regardless of the object’s specified elevation.



To avoid unexpected results, do not draw Elevation Data objects with different elevation information at the same location.

Elevation Points



An **Elevation Point** contains the absolute elevation data for one point in the terrain model. Typically, Elevation Points are imported rather than placed manually.

Home Designer Pro requires many points to make an accurate approximation of your site. Even small sites may require over a hundred points to generate an accurate model of the terrain if it is sloped. For the sake of illustration, the following example shows only a few elevation points.

To place an elevation point

1. Select **Terrain > Elevation Data > Elevation Point**  and click in floor plan view at the point where you would like to place elevation data. See “Place Point” on page 773.
2. The **Elevation Point Specification** dialog opens. Enter an elevation value and click **OK**. See “Elevation Point Specification Dialog” on page 557.
3. Click somewhere else in floor plan view and the **Elevation Point Specification** dialog opens again with the last elevation value entered.

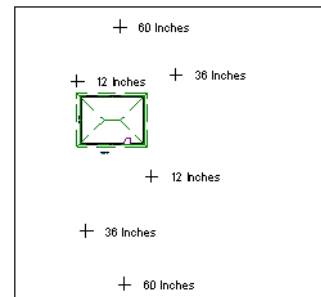

Elevation Points before terrain generation

4. Repeat steps 1, 2 and 3 to place additional elevation points with varied elevation values as needed.
5. Select **Terrain > Build Terrain** . See “Building the Terrain” on page 552.

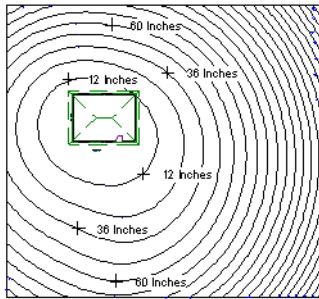



Contour lines after terrain generation

 Elevation Points are most effective when they are imported. When adding elevation data manually, use Elevation Lines and Splines instead. See “Importing Elevation Data” on page 567.

Elevation Lines

 An **Elevation Line** contains absolute elevation data for many points along a line at a constant elevation. Elevation lines can be connected to create a polyline with many straight sections. For the sake of illustration, the images in the following example show single-section elevation lines.

To draw an elevation line

1. Select **Terrain > Elevation Data > Elevation Line** , then click and drag a line inside the Terrain Perimeter in floor plan view.
2. Click on the elevation line to select it, then click the **Open Object**  edit button.

3. At first, an elevation line is at elevation 0' - 0". In the **Elevation Line Specification** dialog, specify the desired elevation and click OK. See “Elevation Line/Region Specification Dialog” on page 559.
4. Repeat steps 2 and 3 to draw additional elevation lines as needed.

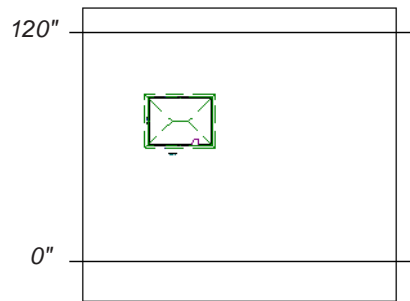

Elevation Lines before terrain generation

5. Select **Terrain > Build Terrain** . See “Building the Terrain” on page 552.

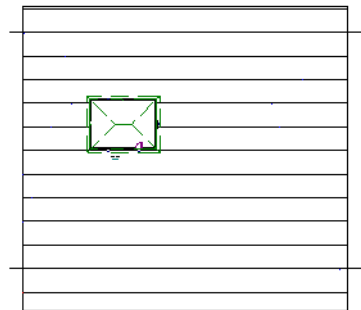

Contour lines after terrain generation



Full Overview after terrain generation

After it is drawn, an Elevation Line can be edited much the way other line-based objects can. See “Editing Line Based Objects” on page 127.

Elevation Splines



Elevation Splines can be used to form complex curves and shapes. Like elevation lines, elevation splines contain absolute elevation data for many points along a constant elevation.

To place an elevation spline, select **Terrain>**

Elevation Data> Elevation Spline  and click and drag multiple sections in floor plan view. See “Splines” on page 796.

Elevation splines are initially placed at elevation 0' - 0" and must be opened and assigned an elevation. See “Elevation Line/Region Specification Dialog” on page 559.

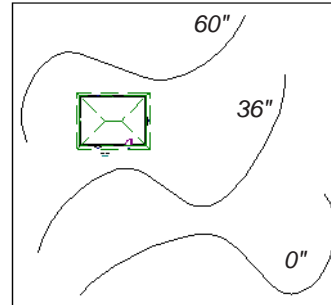

Elevation splines before terrain generation

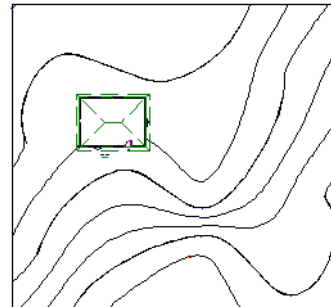

Contour lines after terrain generation

After it is drawn, an Elevation Spline can be edited much the way other spline-based objects can. See “Editing Spline Based Objects” on page 144.

Elevation Regions





An **Elevation Region** contains absolute elevation data for an enclosed region.

Elevation Regions are similar to Flat Regions in that they produce an area with a flat surface; however, they differ in that an Elevation Region affects the contours of the

terrain outside of its perimeter and may also have some sloping within its perimeter. See “Flat Regions” on page 546.

To create an elevation region

1. Select **Terrain> Elevation Data> Elevation Region** .
2. There are two ways to add a Terrain Modifier to your plan:
 - Click once to place an 8’ (0.6 m) square feature at that location.
 - Click and drag from end to end to draw a feature sized as needed. See “Rectangular Polyline” on page 794.
3. Click on the region to select it, then click the **Open Object**  edit button.
4. At first, an elevation line is at elevation 0’ - 0”. In the **Elevation Region Specification** dialog, specify the desired elevation and click OK. See “Elevation Line/Region Specification Dialog” on page 559.

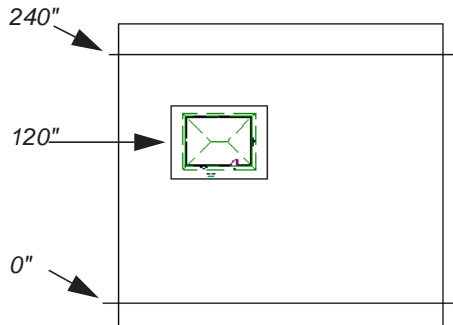

Elevation lines create a terrain grade; an elevation region creates a building pad.

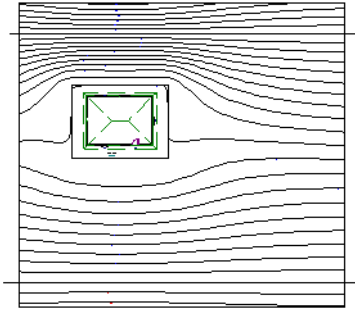

Contour lines after terrain generation



Full Overview after terrain generation

An **Elevation Region**  can also be created by drawing a closed polyline using **Elevation Lines** .

After it is drawn, an Elevation Region can be reshaped much the way other closed polyline-based objects can. See “Editing Closed-Polyline Based Objects” on page 138.

Terrain Breaks



A **Terrain Break** creates a division along the terrain surface that affects terrain generation. Elevation data on one side of the terrain break does not affect the terrain generation on the other side, allowing you to create immediate drops in terrain.

To place a Terrain Break, select **Terrain> Elevation Data> Terrain Break**  and click and drag a line in floor plan view.

- If the Terrain Break divides the terrain perimeter into two separate pieces, the terrain data on either side is calculated independently and smoothed separately, resulting in sharp terrain contours.
- If the Terrain Break does not extend completely from one side of the terrain perimeter to the other, the areas near each end of the Terrain Break are blended.

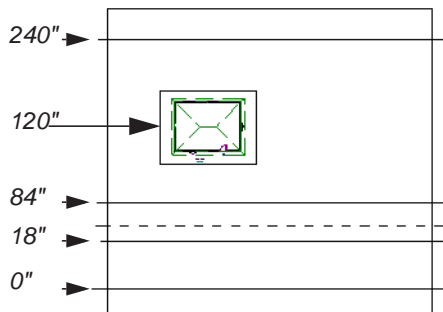

A Terrain Break (dashed line) creates a vertical drop.

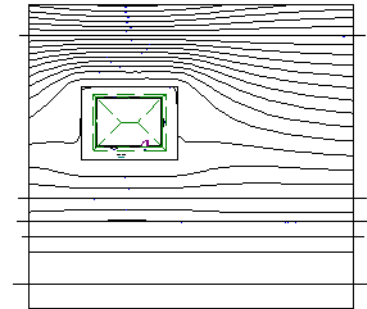

Contour lines after terrain generation



Full Overview after terrain generation

The **Retaining Wall**  tool creates a similar effect by drawing a Terrain Break as well as a retaining wall that rests against the break. By default, the top height of the retaining wall matches the terrain on the high side of the break and the bottom matches the low side. See “Retaining Walls” on page 550.

Terrain Modifier Tools

 Select **Terrain> Modifier** to access tools that allow you to modify the existing elevation data by drawing a closed polyline. Their height is relative to the terrain surface generated from the Elevation Data provided in your plan.

The elevation data associated with a Terrain Modifier only affects the terrain within its perimeter. The rest of the terrain is unaffected.

Raised and Lowered Regions



The **Raised Region** tool creates a raised area with a top surface that is flattened like a plateau but follows the surface of the terrain. The **Lowered Region** tool creates a depression with a bottom that follows the terrain and is flattened.

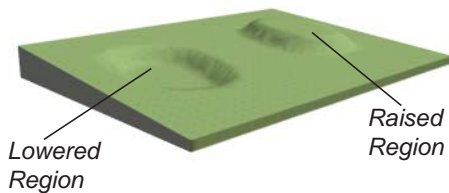

Flat Regions



The **Flat Region** tool creates an area with a surface that is flattened like a plateau but is level rather than following the contours of the terrain.

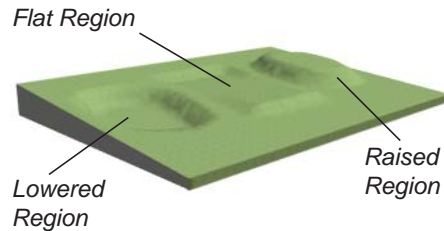

Hills and Valleys



The **Hill** and **Valley** tools create raised and lowered areas in the terrain that come to a point rather than flattening at their highest or lowest elevations.

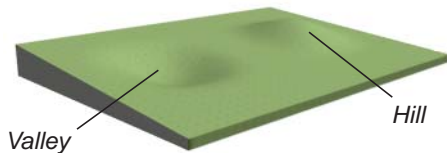

There are two ways to add a Terrain Modifier to your plan:

- Click once to place a modifier with end-points that form a 10' (4 m) square at that location.
- Click and drag from end to end to draw a feature sized as needed. See “Rectangular Polyline” on page 794.

Terrain Modifiers can only be drawn when a Terrain Perimeter is present, and will only display in 3D when they are drawn within the perimeter. See “Displaying Terrain” on page 551.

Once created, Terrain Modifiers can be selected and edited in a variety of ways. See “Editing Spline Based Objects” on page 144.



Terrain Feature Tools



Select **Terrain > Feature** to access tools for drawing bounded areas that follow the contours of the terrain rather than modifying them.

Terrain Features are useful for creating landscaping features because they have specified heights and materials. You can, for example, create paths and planting beds with gravel or mulch materials that stand out in a

grassy Terrain Perimeter. See “Adding Terrain Features” on page 178 of the User’s Guide.

In fact, **Garden Beds** , **Water Features** , and **Stepping Stones**  are special Terrain Features with material and height attributes already applied to them, saving you time when drawing these objects.

Terrain Features can only be drawn when a Terrain Perimeter is present, and will only display in 3D when they are drawn within the perimeter. See “Displaying Terrain” on page 551.

Terrain Features can be created in either of two ways:

- Click once to place a feature with end-points that form a 10’ (4 m) square at that location.
- Click and drag from end to end to draw a feature sized as needed. See “Rectangular Polyline” on page 794.

Once created, Terrain Features can be edited into nearly any shape you require. See “Editing Closed-Polyline Based Objects” on page 138 and “Editing Spline Based Objects” on page 144.

 Terrain Features can be drawn in 2D and 3D views.

Rectangular Features

 The **Rectangular Feature** tool can be used to create straight-sided features that can be edited into a wide variety of shapes.

Rectangular Features can also be edited like other closed polyline-based objects. See

“Editing Closed-Polyline Based Objects” on page 138.

Spline Feature

 The **Spline Feature** tool can be used to create features with rounded edges and smoothly curved corners.

Spline Features can be edited like other closed spline-based objects. See “Editing Spline Based Objects” on page 144.

Kidney Shaped Features

 The **Kidney Shaped Feature** tool allows you to quickly create features with curved edges, smooth corners and a right angle bend in its shape.

Kidney Shaped Features can be edited like other closed spline-based objects. See “Editing Spline Based Objects” on page 144.

Terrain features can also be converted from closed 2D polylines or splines using the

Convert Polyline  edit tool. See “Convert Polyline” on page 165.

For information about adding height and material information to Terrain Features, see “Terrain Feature Specification Dialog” on page 562.

Terrain Holes

 A **Terrain Hole** is a region that cuts a hole in the terrain. Using this tool is the same as creating a Terrain Feature and checking **Make Hole** in the **Terrain Feature Specification** dialog. See “Terrain Feature Specification Dialog” on page 562.

Terrain Holes  are useful for manually clipping the terrain around a foundation that does not match the footprint of the first floor.

Garden Bed Tools

 Select **Terrain > Garden Bed** to access tools that can be used to place garden bed features in your terrain.

Garden Beds are basically **Terrain Features** with material and height attributes typical of planting beds. See “Terrain Feature Tools” on page 546.

In addition, you can choose to distribute copies of a plant image within a Garden Bed. See “Distributed Plant Tab” on page 563.

Polyline Garden Bed

 This tool draws a garden bed with straight sides and four right angles. See “Rectangular Features” on page 547.

Round Garden Bed

 Use this tool to draw garden beds with rounded edges and smoothly curved corners. See “Spline Feature” on page 547.

Kidney Shaped Garden Bed

 You can draw a kidney shaped garden bed with this tool. See “Kidney Shaped Features” on page 547.

Once drawn, Garden Beds can be selected and edited just like other Terrain Features.

Specify the material and set the height of Garden Beds in the **Terrain Feature Specification** dialog. See “Terrain Feature Specification Dialog” on page 562.

Water Feature Tools

 Select **Terrain > Water Feature** to access tools for drawing ponds and streams in your terrain.

Ponds are basically **Terrain Features** with material and height attributes typical of bodies of water. See “Terrain Feature Tools” on page 546.

Similarly, Streams are Terrain Curbs with a water material. See “Terrain Wall and Curb Tools” on page 549.

Round Pond

 Use this tool to draw a pond with rounded edges. See “Spline Feature” on page 547.

Kidney Shaped Pond

 This tool draws a kidney shaped pond. See “Kidney Shaped Features” on page 547.

Stream

 Select the **Stream** tool, then click and drag to draw a stream. Streams are drawn and edited the same way that splines are. See “Splines” on page 796 and “Editing Spline Based Objects” on page 144.

 Streams follow the contours of the terrain, so they may appear to flow uphill if they are not drawn correctly in the terrain.

Try to draw them so that they follow a downward course for their entire length.

Once drawn, Water Features can be selected and edited just like any other Terrain Feature.

Specify the material and set the height of Water Features in their specification dialogs. See “Terrain Object Specification Dialogs” on page 553.

Stepping Stone Tools

 Select **Terrain > Stepping Stone** to place a walkway made of individual stepping stones.

Stepping Stones are basically **Terrain Features** with material and height attributes typical of walking paths. See “Terrain Feature Tools” on page 546.

There are two ways to draw Stepping Stones:

- Click once to place a stepping stone with endpoints that form a 1' (300 mm) square at that location.
- Click and drag from end to end to draw a stepping stone sized as needed. See “Rectangular Polyline” on page 794.

Polyline Stepping Stone

 The **Polyline Stepping Stone** tool draws rectangular stepping stones. See “Rectangular Features” on page 547.

Round Stepping Stone

 The **Round Stepping Stone** tool draws stepping stones with rounded edges. See “Spline Feature” on page 547.

Once drawn, Stepping Stones can be selected and edited just like any other Terrain Feature.

By default, Stepping Stones have a concrete material; however, you can specify the material and set the height of Stepping Stones in the **Terrain Feature Specification** dialog. See “Terrain Feature Specification Dialog” on page 562.

Terrain Wall and Curb Tools

 Select **Terrain > Terrain Wall and Curb** to draw landscaping walls and curbs that follow the contours of the terrain.

Straight and curved Terrain Walls and Curbs are drawn just as other walls are. See “Drawing Walls” on page 189.

Terrain Walls and Curbs are examples of Terrain Paths. Other examples include Sidewalks and Streams. See “Terrain Path Specification Dialog” on page 566.

Terrain Walls

 Use the **Straight Terrain Wall** tool to draw a wall that sits on top of and follows the terrain.

 Use the **Spline Terrain Wall** to draw a curved terrain wall. This wall is drawn the same way as a CAD Spline. See “Splines” on page 796.

Once drawn, a Terrain Wall can be like other line-based objects. See “Editing Line Based Objects” on page 127 and “Editing Spline Based Objects” on page 144.

Terrain walls are 5’ (1500 mm) high and concrete by default, but you can specify the material, height and more in the **Terrain Path Specification**. See “Terrain Path Specification Dialog” on page 566.

Retaining Walls

The **Retaining Wall** tools function similarly to Terrain Breaks, but include a wall. See “Terrain Breaks” on page 544.

 Use the **Straight Retaining Wall** tool draws a straight wall that holds back sloped terrain.

 Use the **Curved Retaining Wall** tool to draw a curved retaining wall.

A Retaining Wall’s height is determined by the elevation of the terrain on each side. By default, the height of the wall matches the terrain on the high side of the break and the bottom matches the low side. If you insert a Retaining Wall into flat terrain, it looks like a concrete strip in 3D views.

Once drawn, a Retaining Wall can be edited much like other walls. See “Editing Walls” on page 197.

Terrain Curbs

Terrain Curbs are useful for creating curbs around planting beds and along paths.

 Use the **Straight Terrain Curb** tool to draw a straight landscaping curb.

 Use the **Spline Terrain Curb** tool to draw a curved landscaping curb. This curb is drawn the same way as a CAD Spline. See “Splines” on page 796.

Once drawn, a Terrain Curb can be like other line-based objects. See “Editing Line Based Objects” on page 127 and “Editing Spline Based Objects” on page 144.

You can specify the height of straight and spline terrain curbs on the General tab of the **Terrain Path Specification**. See “Terrain Path Specification Dialog” on page 566.

 You can also add Fencing to your terrain, complete with gates from the Doors Library. See “The Fencing Tools” on page 183.

Sun Shadows

Sun shadows are computed based on the contour of the terrain. If a terrain perimeter

exists, the sun shadow adjusts to the terrain.

The Sun Shadow is automatically rebuilt whenever terrain is rebuilt. If you generate a Sun Shadow and the terrain is not up-to-date,

the terrain automatically rebuilds. You can turn off the automatic rebuild. See “Sun Angle Specification Dialog” on page 708.

Terrain Objects in the Library



The Library Browser contains a variety of objects that can be placed in a plan’s terrain, including plants, exterior fixtures, accessories and roadway objects. See “The Library Browser” on page 604.

You can also create your own objects and save them in the library. Select any combination of elevation points, elevation

lines, terrain features, roads, sidewalks, road markings, or even the terrain perimeter itself and send them to the library as one unit. This library object can then be placed into any plan. Once placed into a plan, each object is independent and is no longer part of the group. See “Adding Library Content” on page 613.

Displaying Terrain



The display of terrain objects in 2D and 3D views is controlled in the **Layer Display Options** dialog. See “Layer Display Options Dialog” on page 104.

You can customize appearance of Terrain Features, Roads and other terrain objects in floor plan view by changing their line and fill styles. See “Terrain Object Specification Dialogs” on page 553.

Plant images are represented in floor plan view by 2D CAD symbols. You can select a plant’s symbol in the **Plant Image Specification** dialog. See “Image Tab” on page 575.

Contour Lines

When elevation data has been drawn or imported into a plan, contour lines will display in floor plan view. See “Elevation Data Tools” on page 540.

Home Designer Pro can produce both primary and secondary contours. They are on two different layers so you can control their display separately. Contour line labels use the Text Styles assigned to the “Terrain, Primary Contours” and “Terrain, Secondary Contours” layers.

By default, all contour lines are set to be primary, but you can specify secondary contours, frequency and other attributes of contour lines in the **Terrain Specification** dialog. See “Contours Tab” on page 555.

In 3D Views

In order for objects such as Terrain Features and Roads to be visible in 3D views, the Terrain Perimeter layer must also display. In addition, only the portions of these objects that are drawn within the Terrain Perimeter will be seen in 3D views. See “Terrain Feature Tools” on page 546.

A variety of tools are available to help you adjust the perspective of your 3D views. See “Editing 3D Views” on page 684.

Building the Terrain





When terrain is generated, Home Designer Pro gathers all elevation data that has been added to the model and creates a terrain surface. The program interpolates the data to produce smooth contours.

A terrain perimeter with no additional elevation data drawn within it generates terrain that is flat at the elevation 0' - 0", or sea level.

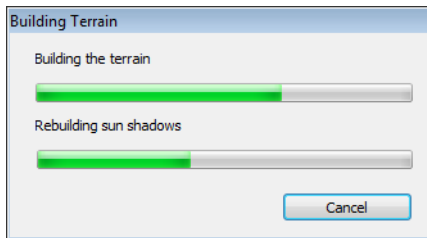
By default, the terrain is automatically built before a 3D view is generated and when a sun shadow is created. This process takes a variable amount of time, depending on the amount of elevation data and number of terrain features in the plan. The **Building Terrain** progress dialog displays as terrain is generated, sometimes only briefly, indicating the progress.



You can turn off **Auto Rebuild Terrain** in the **3D View Defaults** dialog for 3D views and in the **Sun Angle Specification** dialog for sun shadows, and rebuild the terrain manually only when needed by selecting

Terrain > Build Terrain . When **Auto Rebuild Terrain** is turned off and the terrain is not up to date, the Rebuild Terrain  icon displays near your mouse pointer. See “Options Tab” on page 669 and “Earth Data Tab” on page 708.

Terrain & 3D Drawing Time

Terrain is typically large with many surface triangles, which often increases the drawing time of 3D views. The time required is affected by the quality of the terrain, the amount of elevation data and number of terrain features present. For information about surface triangles and how they influence terrain quality, see “General Tab” on page 554.

Lights and symbols can be placed outdoors and included in 3D views when the terrain is generated. These objects can also contribute to the time needed to generate 3D views. See “Rendering Tips” on page 697.

Editing Terrain Objects

Before a terrain object can be edited, it must be selected. All terrain objects can be selected in floor plan view. In addition, the Terrain Perimeter and Terrain Features can

be selected in 3D views. See “Selecting Objects” on page 124.

A selected terrain object can be edited using its edit handles, edit tools and specification

dialog. See “Specification Dialogs” on page 31.

Any time elevation data is changed, the terrain must be regenerated. This occurs automatically when a 3D view is created. It can also be done manually by selecting

Terrain > Build Terrain 

Using the Edit Handles

- The shape of the Terrain Perimeter can be edited like other polyline-based objects. See “Editing Closed-Polyline Based Objects” on page 138.
- Elevation Points can be moved in floor plan view using the Move edit handle.
- **Elevation Lines, Elevation Splines** and **Terrain Breaks** are edited like other line- and spline-based objects. See “Editing Line Based Objects” on page 127, “Editing Closed-Polyline Based Objects” on page 138, and “Editing Spline Based Objects” on page 144.
- The shape of a **Raised Region, Lowered Region, Hill, Valley, and Flat Region** can be edited like a spline. See “Editing Spline Based Objects” on page 144.
- Terrain Features are edited like other spline- and polyline-based objects. See

“Editing Closed-Polyline Based Objects” on page 138 and “Editing Spline Based Objects” on page 144.

Using the Edit Tools

A selected terrain object can be edited in a variety of ways using the buttons on the edit toolbar. The edit tools available for a terrain object depends on the type of terrain object selected. See “The Edit Toolbar” on page 29.

Note: If you copy terrain objects from one plan to another, you cannot view the pasted objects in 3D unless a Terrain Perimeter exists.

Moving Terrain Objects Using Dimensions

If dimensions display when a terrain object is selected, the object can be moved using the them. For more information see “Moving Objects Using Dimensions” on page 737.

Plot Plans

Using the CAD drawing and editing tools, you can create an accurate plot plan of any building site. For more information, see “Creating a Plot Plan” on page 195 of the User’s Guide.

Terrain Object Specification Dialogs





Just as there are a number of different types of terrain objects, there are a

number of different specification dialogs for them.

Terrain Specification Dialog

 The **Terrain Specification** dialog controls how your terrain is modeled, as well as its appearance.

The **Terrain Specification** dialog can be accessed in any of three ways:

- Select **Terrain > Terrain Specification** .
- Select the Terrain Perimeter and click the **Open Object**  edit button.
- Double-click the Terrain Perimeter using the **Select Objects**  tool.

General Tab

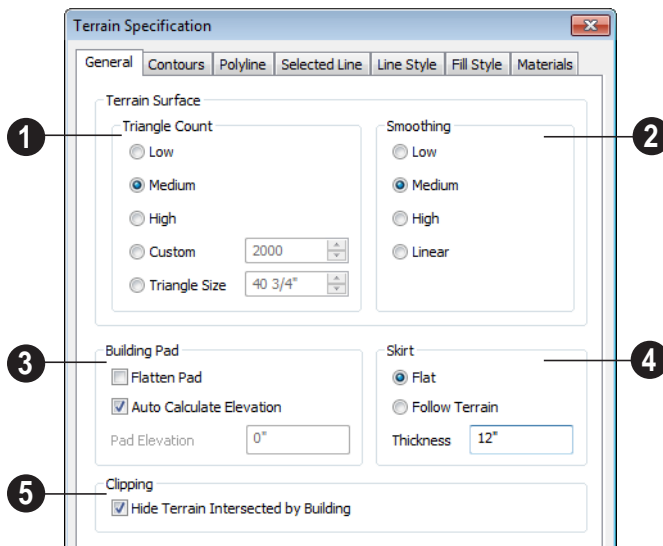

Home Designer Pro builds 3D terrain surfaces by splitting them into triangles. See “Terrain Surface Triangles” on page 540.

Triangles are computed roughly as follows:

Size of Triangle = Area of Terrain Perimeter /
Number of Triangles

The Low (1000), Medium (2000), and High (4000) values work well for a terrain perimeter of approximately 20,000 sq ft

(1858 m²). If your terrain perimeter varies greatly from this, consider defining the number of triangles using the **Custom** setting or the **Triangle Size** setting.

- 1 Triangle Count** - Specify the number of surface triangles used to generate the terrain in 3D views. A lower count value will generate more quickly but with reduced quality.

- **Custom** - Specify a custom triangle count value.
 - **Triangle Size** - Specify the maximum triangle size in the terrain surface. Smaller triangles produce better quality results in 3D but take longer to generate.
- ② **Smoothing** - Control the amount of rounding applied to terrain edges. A low value for smoothing produces terrain that has sharp peaks and abrupt changes in slope. A high value results in terrain that continuously flows from point to point.
- ③ Specify how the **Building Pad** is generated beneath the structure. See “Foundations and the Terrain” on page 339.
- Check **Flatten Pad** to flatten the area beneath the building. To create a walkout basement, uncheck this box.
 - Check **Auto Calculate Elevation** to have Home Designer Pro automatically position the first floor 6” (150 mm) above the terrain. See “Terrain Height vs Floor Height” on page 539.
 - To specify the distance between Floor 1 and the terrain at the building footprint center, uncheck Auto Calculate Elevation

and enter a value in the **Pad Elevation** field.

- ④ Check **Hide terrain intersected by building** to cut out the portion of the terrain that is intersected by the first floor footprint. Checking this box prevents the generation of contour lines inside the house.

If your foundation footprint differs from your first floor footprint, you may need to use the

Terrain Hole  tool for custom clipping instead. See “Terrain Feature Tools” on page 546.

- ⑤ Define the thickness of the **Skirt** added to the terrain. The skirt is only visible in 3D views and gives the viewer a sense of depth when viewing the terrain.
- **Flat** specifies that the skirt be flat at its base. Home Designer Pro determines the lowest point in the terrain and then offsets this value by the user specified thickness value. The resulting value is used as a uniform elevation for the base of the skirt.
 - **Follow Terrain** specifies that the skirt base maintains a consistent distance below the terrain. The distance is equivalent to the specified Thickness value.

Contours Tab

Home Designer Pro identifies two types of contour lines: Primary and Secondary. They

are drawn on different layers, so you can

control how they display in floor plan view.
See “Contour Lines” on page 551.

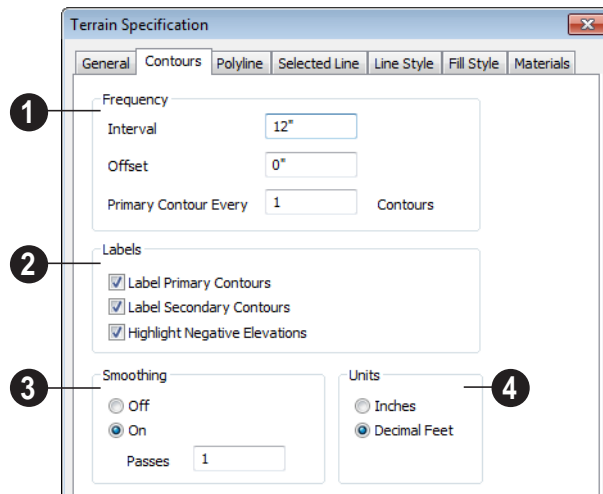

1 Specify the **Frequency** at which contour lines are generated.

- Define the **Interval** between contour lines, which is the change in elevation between contours. If the interval is set to 12”, a contour line is computed for each elevation change of 12”.
- Specify the **Offset** value. When the Offset is 0, a contour line will be drawn at zero elevation and additional contours will generate based on the Interval value. If the Offset is changed to 5, a contour line will be drawn 5 units from zero elevation rather than at 0, and additional contours will generate from there.
- **Primary Contour Every__Contours** - Specify the interval for primary contours. A value of 1 produces only primary contours, while a value of 5 defines every fifth contour line as a primary contour.

2 Control the display of contour line **Labels** in floor plan view.

- Check **Label Primary Contours** to label primary contour lines with their elevation data using the Units specified below.
- Check **Label Secondary Contours** to label secondary contour lines with their elevation data.
- Check **Highlight Negative Elevations** to display labels of contour lines with elevations below 0 in red. When unchecked, they use the color set in the Text Style assigned to their layer.



Primary and secondary contour line labels use the Text Style assigned to their respective layers. See “Text Styles” on page 765.

3 If contour **Smoothing** is turned on, Home Designer Pro attempts to remove

sharp bends and jagged sections from the 2D contour lines.

- Specify the number of **Passes** to perform when smoothing. The more passes, the smoother the contour lines become, but contours become less accurate.

4 Specify the **Units** used by contour line labels. Select either **Inches** or **Decimal Feet** (**Millimeters** or **Meters** for metric).

Polyline Tab

The Polyline tab indicates the polyline's **Length/Perimeter**, its enclosed **Area**, and its **Volume**.

The settings on the this tab are available for a variety of other objects in the program. For information about these settings, see “Polyline Tab” on page 792.

Selected Line Tab

The Selected Line tab is available when the selected edge of the Terrain Perimeter is a line as opposed to an arc. See “Selected Edge” on page 125.

The settings on this tab are available for a variety of other objects in the program. For information about these settings, see “Line Tab” on page 780.

Selected Arc Tab

The Selected Arc tab is available when the selected segment of the polyline is an arc as opposed to a line. See “Change Line/Arc” on page 159.

The settings on this tab are available for a variety of other objects in the program. For information about these settings, see “Arc Tab” on page 787.

Line Style Tab

The settings on the Line Style tab are available for a variety of other objects in the program. For information about these settings, see “Line Style Tab” on page 781.

Fill Style Tab

The settings on the Fill Style tab affect the appearance of the Terrain Perimeter in floor plan view. For information about these settings, see “Fill Style Tab” on page 792.

Materials Tab

The settings on the Materials tab let you specify the terrain surface and terrain skirt materials used in 3D views. These materials are not calculated in the Materials List. See “Materials Tab” on page 635.

Elevation Point Specification Dialog



To open the **Elevation Point Specification** dialog, select an elevation point and click the **Open Object** edit button, or double-click on an elevation point

using the **Select Objects**  tool.

Use the **Elevation Point Specification** dialog to define the selected elevation point and control its appearance in floor plan view.

When all changes are made, click **OK** to store the changes or **Cancel** to ignore them.

General Tab

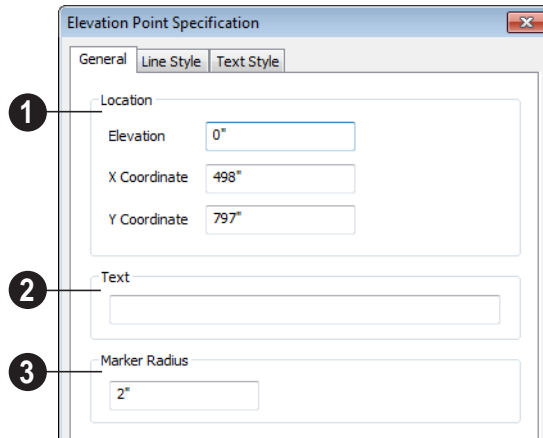

1 Location - Specify the exact location of the elevation point.

- **Elevation** - Enter the height of the elevation point in inches and/or feet (mm for metric). For example entering 5'6 (with the apostrophe as foot mark) results in an elevation of 66 inches.
- **X Coordinate** - Enter the x coordinate of the elevation point.
- **Y Coordinate** - Enter the y coordinate of the elevation point.

2 Text - Enter notes, such as elevation, in this box. This text displays beside the elevation point in floor plan view. You can also enter a pound (#) sign to display the elevation value in floor plan view.

3 Enter the **Marker Radius** in inches (or millimeters).



Line Style Tab

The settings on the Line Style tab are available for a variety of other objects in the program. For information about these settings, see “Line Style Tab” on page 781.

Text Style Tab

The settings on the Text Style tab control the appearance of the selected Elevation Point's text. For more information, see “Text Style Tab” on page 766.

Elevation Line/Region Specification Dialog

 To open the **Elevation Line** or **Elevation Region Specification** dialog, select one or more Elevation Line/Splines, or a polyline composed of elevation Lines/Splines, or an Elevation Region and click the **Open Object** edit button. You can also double-click an Elevation Line/Spline using the **Select Objects**  tool.

The **Elevation Line Specification** dialog is used to define the selected Elevation Line/Spline and controls its appearance in floor plan view.

The settings in this dialog are the same as those in the **Elevation Region Specification** dialog. See “Elevation Regions” on page 543.

Elevation Tab

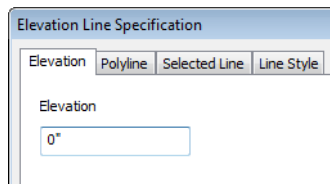

Elevation - Enter the elevation of the Line/Spline in inches and/or feet (mm for metric). For example entering 5'6 (with the apostrophe as foot mark) results in an elevation of 66 inches.

Polyline Tab

The Polyline tab indicates the line or polyline's **Length/Perimeter**. If multiple Elevation Line/Spline segments form a closed Elevation Region, its Area will be

calculated. Elevation Lines/Splines do not have a thickness, so they have no Volume.

Spline Tab

The Spline tab has a single option and is only available when the selected object is an elevation spline. See “Splines” on page 796.

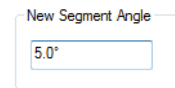

New Segment Angle - Specify the angle between line segments that are used to draw the spline. Specifying a smaller angle makes the spline smoother. Specify a larger angle to draw the spline faster.

Selected Line Tab

The Selected Line tab is available when the selected object or segment is a line as opposed to one that has been converted to an arc. See “Selected Edge” on page 125.

The settings on this tab are available for a variety of other objects in the program. For information about these settings, see “Line Tab” on page 780.

Selected Arc Tab

The Selected Arc tab is available when the selected object or segment is an arc as opposed to a line.

The settings on this tab are available for a variety of other objects in the program. For information about these settings, see “Arc Tab” on page 787.

Line Style Tab

The settings on the Line Style tab are available for a variety of other objects in the

program. For information about these settings, see “Line Style Tab” on page 781.

Flat Region Specification Dialog



To open the **Flat Region Specification** dialog, select a Flat Region and click the **Open Object** edit button, or double-click a Flat Region using the **Select Objects**  tool. See “Flat Regions” on page 546.

The options in the **Flat Region Specification** dialog are similar to those a number of other dialogs in the program.

Polyline Tab

The Polyline tab indicates the length of the polyline’s **Length/Perimeter**, its enclosed **Area**, and the **Volume** of a closed polyline.

Spline Tab

The Spline tab has a single option and is only available when the selected object is a spline. See “Splines” on page 796.

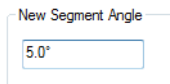

New Segment Angle - Specify the angle between line segments that are used to draw the spline. Specifying a smaller angle makes the spline smoother. Specify a larger angle to draw the spline faster.

Selected Line Tab

The Selected Line tab is available when the selected edge of the polyline is a line as opposed to an arc. See “Selected Edge” on page 125.

Moving the Start of a line segment moves the end of the previous connected line, if there is one. Similarly, moving the End of a line segment moves the start of the next connected line, if there is one.

The settings on this tab are available for a variety of objects in the program. For information about these settings, see “Line Tab” on page 780.

Selected Arc Tab

The Selected Arc tab is available when the selected segment of the polyline is an arc as opposed to a line. See “Change Line/Arc” on page 159.

The settings on this tab are available for a variety of objects in the program. For information about these settings, see “Arc Tab” on page 787.

Line Style Tab

The settings on the Line Style tab are available for a variety of objects in the program. For information about these settings, see “Line Style Tab” on page 781.

Fill Style Tab

The settings on the Fill Style tab affect the appearance of the selected object in floor

plan view. For information about these settings, see “Fill Style Tab” on page 792.

Hill / Valley Specification Dialog



The **Hill/Valley Specification** defines the selected Hill or Valley and controls its appearance in floor plan view.

To open the **Hill/Valley Specification** dialog, select one or more Hill or Valley and click the **Open Object** edit button, or double-click the region(s) using the **Select Objects**  tool.

Hill / Valley Tab

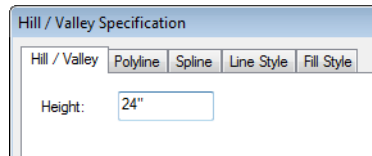

Enter a **Height** for the selected Hill or Valley. This height is relative to the terrain surface that is generated from the Elevation Data in your plan. See “Terrain Modifier Tools” on page 545.

Polyline Tab

The Polyline tab indicates the polyline’s **Length/Perimeter** and its enclosed **Area**. Hills and Valleys do not have a volume measurement.

Spline Tab

The Spline tab has a single option and is only available when the selected object is a spline. See “Splines” on page 796.

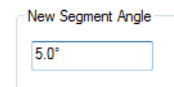

New Segment Angle - Specify the angle between line segments that are used to draw the spline. Specifying a smaller angle makes the spline smoother. Specify a larger angle to draw the spline faster.



Line Style Tab

The settings on the Line Style tab are available for a variety of other objects in the program. For information about these settings, see “Line Style Tab” on page 781.

Fill Style Tab



The settings on the Fill Style tab affect the appearance of the selected object in floor plan view. For information about these settings, see “Fill Style Tab” on page 792.

Raised / Lowered Region Specification Dialog

 To open the **Raised/Lowered Region Specification** dialog, select one or more raised or lowered regions and click the **Open Object** edit button, or double-click the region(s) using the **Select Objects**  tool.

The **Raised / Lowered Region Specification** dialog is similar to the **Hill / Valley Specification** dialog. See “Hill / Valley Specification Dialog” on page 561.

Terrain Feature Specification Dialog

 To open the **Terrain Feature Specification** dialog, select a Terrain Feature or group of Terrain Features and click the **Open Object** edit button or double-click the Terrain Feature(s) using the **Select Objects**  tool.

The settings in this dialog control the appearance, size, and shape of the selected Terrain Feature.

Most of the tabs in this dialog are similar to those for a variety of other objects in the program.

General Tab

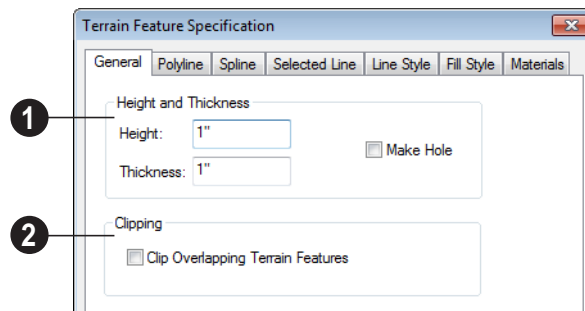

1 Specify the **Height and Thickness** of the terrain feature relative to the terrain surface.

- Specify the top **Height** of the feature using a positive or negative number.
- Specify the feature’s **Thickness**.

If a feature’s height above the terrain is greater than its thickness, the program will fill in the resulting gap.

- Check **Make Hole** to specify the selected Terrain Feature as a Terrain Hole. See “Terrain Holes” on page 547.

2 **Clipping** - Check **Clip Overlapping Terrain Features** to suppress the 3D display of any part of the selected Terrain Feature intersected by other Terrain Features with a lower Height value. Clipping is useful

for creating features that contain other features such as planters or swimming pools.

Distributed Plant Tab

This tab is only available when the selected terrain feature is a Garden Bed. See “Garden Bed Tools” on page 548.

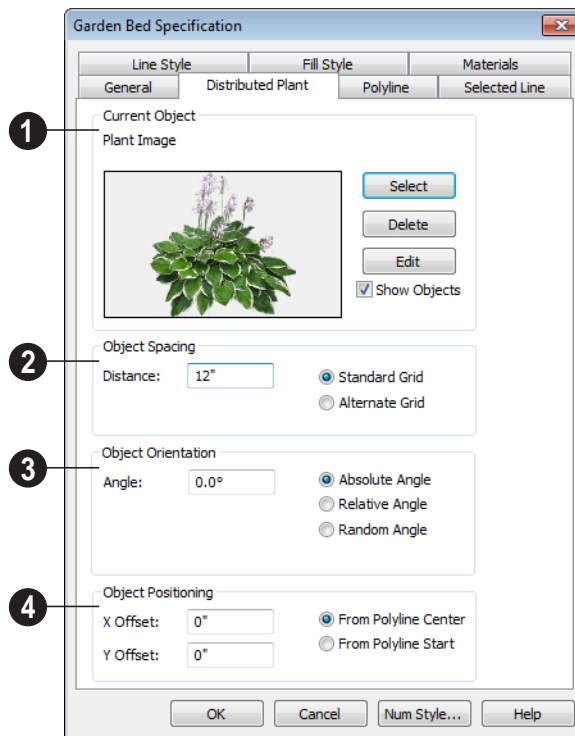

Polyline Tab

The Polyline tab indicates the polyline’s **Length/Perimeter**, its enclosed **Area**, and the **Volume** of a closed polyline.

Spline Tab

The Spline tab has a single option and is only available when the selected object is a spline. See “Splines” on page 796.

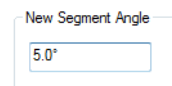

New Segment Angle - Specify the angle between line segments that are used to draw the spline. Specifying a smaller angle makes the spline smoother. Specify a larger angle to draw the spline faster.

Selected Line Tab

The Selected Line tab is available when the selected edge of the Terrain Perimeter is a line as opposed to an arc. See “Selected Edge” on page 125.

The settings on this tab are available for a variety of other objects in the program. For information about these settings, see “Line Tab” on page 780.

Selected Arc Tab

The Selected Arc tab is available when the selected segment of the polyline is an arc as opposed to a line. See “Change Line/Arc” on page 159.

The settings on this tab are available for a variety of other objects in the program. For

information about these settings, see “Arc Tab” on page 787.

Line Style Tab

The settings on the Line Style tab are available for a variety of other objects in the program. For information about these settings, see “Line Style Tab” on page 781.

Fill Style Tab

The settings on the Fill Style tab affect the appearance of the selected object in floor plan view. For information about these settings, see “Fill Style Tab” on page 792.

Materials Tab

The settings on the Materials tab affect the appearance of the selected object in 3D views. See “Materials Tab” on page 635.

Garden Bed Specification Dialog



To open the **Garden Bed Specification** dialog, select a Garden Bed or group of Garden Beds and click the **Open Object** edit button or double-click the Garden Bed(s) using the **Select Objects**  tool.

Because a Garden Bed is a type of terrain feature, the settings in this dialog are essentially the same as those in the **Terrain Feature Specification** dialog. See “Terrain Feature Specification Dialog” on page 562.

Terrain Break Specification Dialog



To open the **Terrain Break Specification** dialog, select a Terrain

Break or group of Terrain Breaks and click the **Open Object** edit button or double-click

the Terrain Break(s) using the **Select Objects**

 tool. See “Terrain Breaks” on page 544.

General Tab

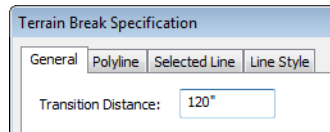

Transition Distance - Define the distance from the edge of the terrain break to where the break stops affecting the terrain.

Polyline Tab

The Polyline tab indicates the line or polyline’s **Length/Perimeter**. Terrain Breaks do not have a thickness, so they have no **Volume**. If multiple Terrain Break segments form a closed polyline, its **Area** will be calculated.

Spline Tab

The Spline tab has a single option and is only available when the selected object was converted to a Terrain Break from a spline. See “Splines” on page 796.

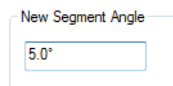

New Segment Angle - Specify the angle between line segments that are used to draw the spline. Specifying a smaller angle makes the spline smoother. Specify a larger angle to draw the spline faster.

Selected Line Tab

The Selected Line tab is available when the selected edge of the polyline is a line as opposed to an arc. See “Selected Edge” on page 125.

Moving the Start of a line segment moves the end of the previous connected line, if there is one. Similarly, moving the End of a line segment moves the start of the next connected line, if there is one.

This tab is similar to the Line tab of the **Line Specification** dialog. See “Line Tab” on page 780.

Selected Arc Tab

The Selected Arc tab is available when the selected segment of the polyline is an arc as opposed to a line.

This tab is similar to the Arc tab of the **Arc Specification** dialog. See “Arc Tab” on page 787.

Line Style Tab

For information about the Line Style tab, see “Line Style Tab” on page 781.

Fill Style Tab

The Fill Style tab is only available when multiple Terrain Break segments enclose an area. The settings on this tab affect the appearance of the closed shape in floor plan view. For more information, see “Fill Style Tab” on page 792.

Terrain Path Specification Dialog



To open the **Terrain Path Specification** dialog, select one or more Streams, Terrain Walls or Terrain Curbs and click the **Open Object** edit button or double-click the terrain path(s) using the **Select Objects**  tool.

Most of the tabs in this dialog are similar to those for a variety of other objects in the program.

General Tab

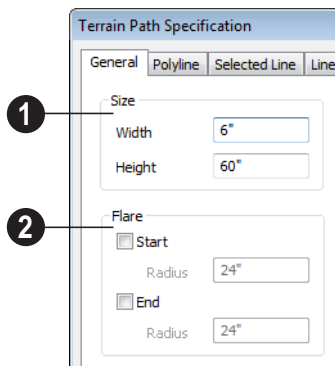

- 1 Enter the **Width** of the object and the **Height**. If you enter a negative number for the height, the object sinks into the terrain.
- 2 When one terrain path joins another, you can **Flare** the intersection.
 - Check **Start** and/or **End** to create a flare at that end of the terrain path.

- Specify the **Radius** for each flare in inches (mm).

Polyline Tab

The Polyline tab indicates the Terrain Path polyline's **Length/Perimeter**, its enclosed **Area**, and the **Volume** of a closed polyline.

Spline Tab

The Spline tab has a single option and is only available when the selected object is a spline path. See "Splines" on page 796.

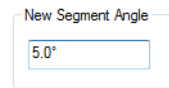

New Segment Angle - Specify the angle between line segments that are used to draw the spline. Specifying a smaller angle makes the spline smoother. Specify a larger angle to draw the spline faster.

Selected Line Tab

The Selected Line tab is available when the selected edge of the Terrain Perimeter is a line as opposed to an arc. See "Selected Edge" on page 125.

The settings on this tab are available for a variety of other objects in the program. For information about these settings, see "Line Tab" on page 780.

Selected Arc Tab

The Selected Arc tab is available when the selected segment of the polyline is an arc as opposed to a line. See “Break Line” on page 158.

The settings on this tab are available for a variety of other objects in the program. For information about these settings, see “Arc Tab” on page 787.

Line Style Tab

The settings on the Line Style tab are available for a variety of other objects in the

program. For information about these settings, see “Line Style Tab” on page 781.

Fill Style Tab

The settings on the Fill Style tab affect the appearance of the selected object in floor plan view. For information about these settings, see “Fill Style Tab” on page 792.

Materials Tab

The settings on the Materials tab affect the appearance of the selected object in 3D views. See “Materials Tab” on page 635.

Importing Elevation Data

Elevation data can be added to a plan using the tools and techniques described in this chapter or it can be imported from a file.

Home Designer Pro can import elevation data saved in DXF, GPS Exchange (.gpx) and a variety of text file formats (.txt, .csv, .prn, .xyz, .auf and .nez). If your terrain data is not saved in one of these file formats, there are third party programs available that can convert to these formats.

DXF Files

If you have a model of your terrain created on another program that contains contour lines and elevation data, that information can be imported directly as elevation data into Home Designer Pro as a .dxf file. See “Importing DXF Elevation Data” on page 572.

Text Files

Elevation data can be saved in text files as x, y, and z coordinates where x and y define the location of a point on a Cartesian grid, and z defines the elevation for that point. Each elevation point must be on a separate line in the text file.

Importable text files can come from surveyors, other software programs, or you can create your own using a GPS system.

Elevation data saved in text files can be imported using the **Import Terrain Wizard**.

GPS Exchange Files

Elevation data in standard format .gpx files created using a GPS system can also be imported using the **Import GPS Data Wizard**. See “Import GPS Data Wizard” on page 570.

GPS data may include three types of points - Way, Track, and Route. Home Designer Pro can only import a **.gpx** file if it includes one or more Way Points, and cannot use Route Points at all. If a **.gpx** file does not include any Way Points, it will not be imported, and

if it includes any Route Points, they will be ignored.

Home Designer Pro supports the import of data in standard **.gpx** files that adhere to the GPX 1.1 Schema. Files that do not follow this standard cannot be imported.

Import Terrain Wizard



The **Import Terrain Wizard** allows you to import elevation data saved in text (**.txt**) file format into your model.

Select **File > Import > Terrain Data**  to open the **Import Terrain Wizard**. Click **Next**.

Select File

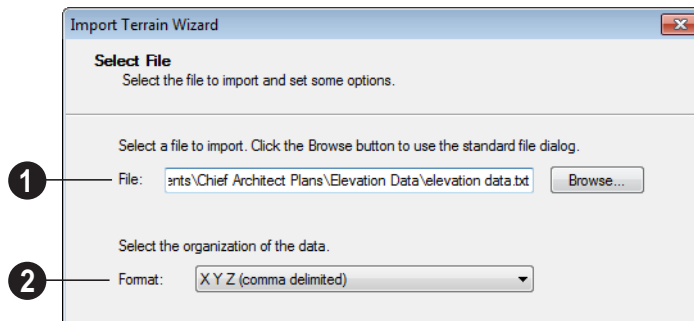

1 Select File to Import -Enter the name of a text file, or Browse to locate a file on your computer.

2 Select the Organization of the Data - You need to know how the data in your text file is organized. Each data point contains information about its X-axis (East to West location), Y-axis (North to South location), and Z-axis (elevation). It might also contain a brief description.

Elevation information can come in one of six different sequences, and is separated by either a comma (comma delimited) or a space (space delimited).

XYZ - Information in this format begins with the X coordinate, followed by the Y coordinate and the Z coordinate.

#XYZ - Information in this format begins with a number that belongs to each data point followed by the X coordinate, the Y coordinate, and the Z coordinate.

#XYZ Description - Information in this format begins with a number that belongs to each data point followed by the X coordinate, the Y coordinate, the Z coordinate, and a description.

YXZ - Information in this format begins with the Y coordinate followed by the X coordinate and the Z coordinate.

#YXZ - Information in this format begins with a number that belongs to each data point followed by the Y coordinate, the X coordinate, and the Z coordinate.

#YXZ Description - Information in this format begins with a number that belongs to each data point followed by the Y coordinate, the X coordinate, the Z coordinate, and a description.

Scale Data

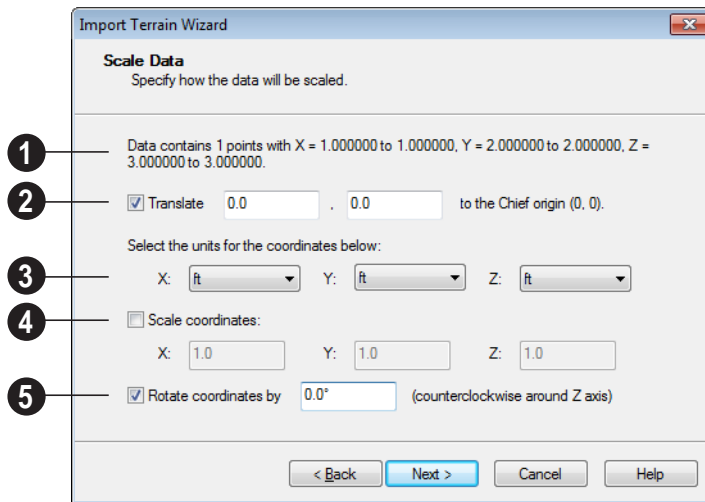

1 This describes the total number of data points to be imported and the range of the coordinates of those points.

2 Translate - Accurately position the terrain beneath your plan. You need to know where the origin is located in your plan, and where that origin is located relative to the geographical data in your text file. The coordinates of the data point that correspond with the origin point in Home Designer Pro should be entered here.

 To find the origin point in your plan, open the Move Point dialog, enter absolute coordinates X=0, Y=0, and click OK to move the point to the (0, 0) location. See “Move Point Dialog” on page 775.

3 Units - Select the units of measurement used in your data for each axis. Only linear units are available. The units in the drop-down lists are a subset of the units in the **Edit Preferences** dialog. For more information on specifying default units, see “Unit Conversions Panel” on page 71.

4 Scale Coordinates - Multiply the coordinates of each axis by a specific number to decrease or increase the relative size or relief of your terrain.

5 Rotate Coordinates - Accurately rotate terrain data counterclockwise around the Z axis.

Import GPS Data Wizard

 The Import GPS Data Wizard allows you to import terrain data from the standard **.gpx** file format. Select **File> Import> GPS Data** to open the **Import GPS Data Wizard**. See “GPS Exchange Files” on page 567.

Click **Next** to continue.

 Due to the lack of accuracy in some GPS systems, exact distances using the Import GPS Data Wizard are not guaranteed.

Select File

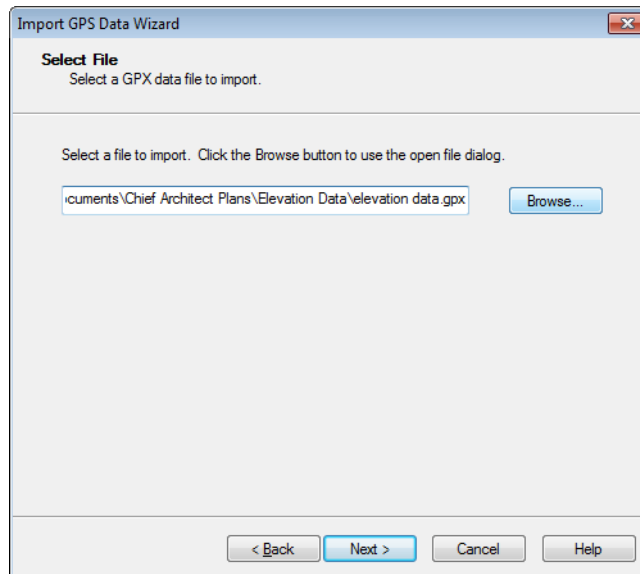

Enter the name and directory of the file you want to import, or click **Browse** to select a **.gpx** file on your computer.

Note: Not all GPS programs use the standard **.gpx** file format; however, only files using the standard format can be imported.

Click **Next** to continue.

Import Data As

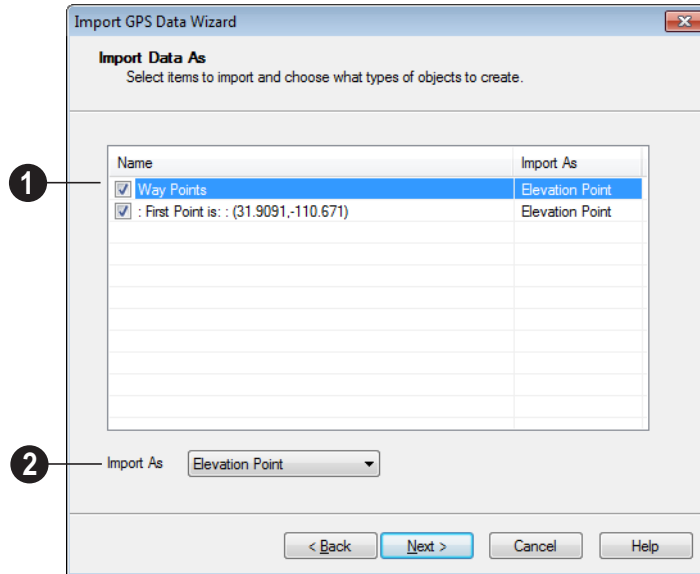

1 Specify which items you want to import by checking the box to the left of the **Name**. Items with unchecked boxes are not imported.

2 Specify what you would like each item to **Import As** from the drop-down list.

- Only Way Points have elevation data associated with them. To import this data, import them as “Elevation Data”.
- Select “Marker” to import either Way Points or Track Points as location markers. Markers have no elevation data associated with them.
- Select “Polyline” to create an open CAD polyline based on the position of Way

Points or Track Points. The points themselves are not imported. Polylines have no elevation data associated with them.

- Select “Terrain Perimeter” to create a closed Terrain Perimeter polyline based on the position of either Way Points or Track Points. The points themselves are not imported. A Terrain Perimeter has no elevation data associated with it. See “Terrain Perimeter” on page 538.

 Way Points are typically imported as “Elevation Data”, while Track Points are imported as “Markers”, “Polylines”, or “Terrain Perimeter”.

Click **Next** to continue.

Transform Coordinates

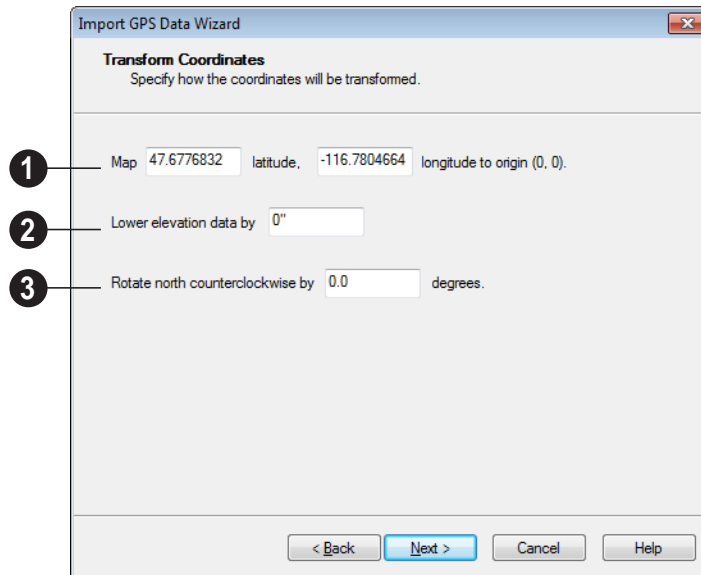

1 Map - Specify the point in the imported terrain data, defined by degrees **latitude** and degrees **longitude**, that you would like to locate at the origin in the Home Designer Pro plan.

2 Lower Elevation Data - Specify the amount that you would like to lower all imported elevation data.

3 Rotate - Accurately rotate the position of north in the imported terrain data counterclockwise around the Z axis.

Click **Finish** to close the **Import GPS Data Wizard** and return to floor plan view.

If you do not see the imported terrain, select **Window > Fill Window** .

Importing DXF Elevation Data



Select **File > Import > Drawing (DXF)** to open the **Import Drawing Wizard**, which you can use to import elevation data in .dxf format. See “Import Drawing Wizard” on page 829.

On the Select File page of the Wizard, check the **Terrain Elevation Data** box.

Lines and points in the imported drawing are converted to elevation lines and elevation points, preserving the elevation data associated with them.

- If an imported line has vertices with the same Z values, an elevation line is created.

- If the vertices have differing Z values, an elevation point is created for each vertex.
- Imported points are converted to elevation points.
- Other imported entities (solids, faces, etc.) are imported normally.



When importing elevation data, only import layers containing this data. To import other layers as normal CAD, run the Terrain Import Wizard again with Terrain Elevation data unchecked.

If a terrain perimeter does not already exist in the plan, a perimeter that surrounds the data is generated.

Converting CAD Lines to Terrain Data



CAD lines can be selected and converted to terrain data using the **Convert Polyline** edit tool.

Using this tool, you can convert CAD lines in an imported drawing into terrain data that can be used to generate a 3D terrain model.

Select a CAD line, spline, or polyline in floor plan view and click the **Convert**

Polyline  edit button to open the **Convert**

Polyline dialog. See “Convert Polyline Dialog” on page 165.

If a terrain perimeter is not present in your plan, this will be the only terrain object available to select. A terrain perimeter must exist before any of the other terrain objects can be created.

When you click **OK**, the terrain object’s specification dialog opens, allowing you to specify elevation data or other attributes.

Plant Tools



Select **Terrain> Plant** to add plants to your landscaping plan. Plants can also be placed in a plan directly from the library. See “Placing Library Objects” on page 620.

Plant objects are actually images, which provide realism while avoiding high 3D surface count. Once created, plant images can be selected and edited much like other image objects. See “Editing Images” on page 808.

Plants have labels which you can display in floor plan view.



Select **Terrain> Plant> Plant Chooser** to open the **Plant Chooser** dialog. See “Plant Chooser Dialog” on page 577.



Select **Terrain> Plant> Create Plant Image** to create a plant image. Once a plant image is created, it can be added to the library for future use. See “Adding Library Content” on page 613.



Choose **Terrain> Plant> Grow All Plants** to open the **Grow Plants** dialog.

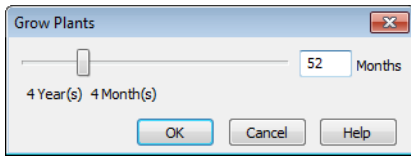

Click and drag the slider bar and select a growth period from zero to twenty years. This only works for plants that have a mature height and mature age specified in the **Plant Image Specification** dialog. See “Plant Information Tab” on page 576.

Select **Terrain> Plant> Show Hardiness Zones** to access regional climate zone maps. See “Hardiness Zones” on page 579.

Plant Schedules

The **Plant Schedule** tool allows you to create customizable plant schedules and plant labels that display schedule numbers. See “Plant Schedules & Object Labels” on page 879.

Plant Image Specification Dialog

Select one or more plant in a floor plan or 3D view and click the **Open Object** edit button to open the **Plant Image Specification** dialog.

This dialog can also be accessed by selecting **Terrain> Plant> Create Plant Image** .

The Plant Information and Plant Description tabs are also found in the **Plant Information** dialog, which can be accessed from the **Plant Chooser** dialog. See “Plant Chooser Dialog” on page 577.

Image Tab

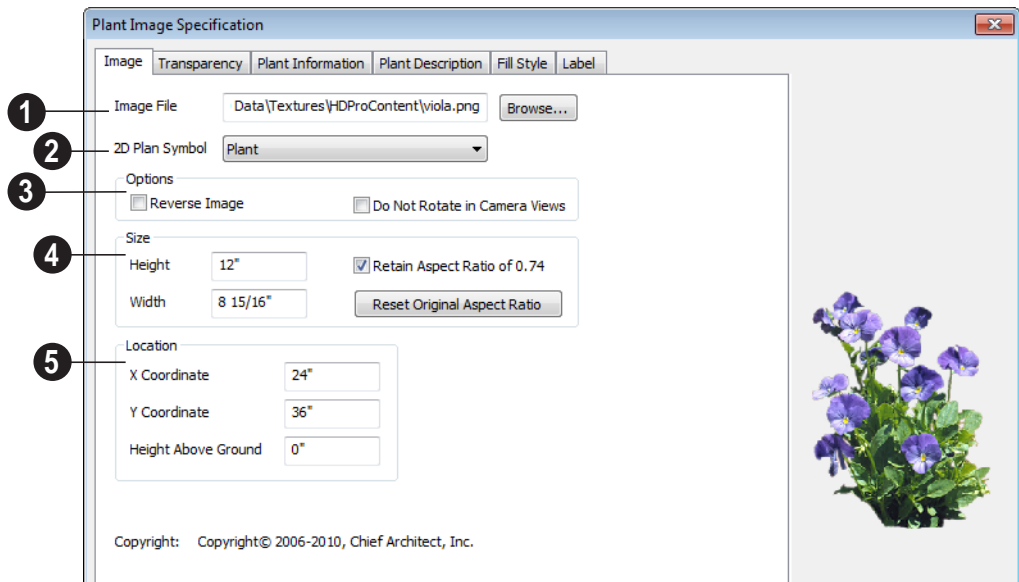

1 **Image File** - The path and name of the selected image file displays here. Click **Browse** to specify the saved location on your computer of the image that represents the plant in 3D views.

2 A number of **2D Plant Symbols** are available to mark the location of the image in floor plan view. Select one from the drop-down list.

3 **Options**

- Check **Reverse Image** to reflect the appearance of the image about an imaginary vertical line through its center.
- Check **Do not rotate in 3D view** to prevent the plant image from rotating with the camera.

4 Specify the **Size** of the plant image, as seen in 3D views.

- Enter a **Height** for the image.
- Enter a **Width** for the image.
- When **Retain Aspect Ratio of** is checked, if you change either the Height or Width, the other value changes to maintain this ratio. If this is unchecked and you resize the plant image, it may become distorted.
- Click **Reset Original Aspect Ratio of** to reset the image's original aspect ratio and remove any distortion caused by resizing.

5 Specify the **Location** of the selected plant image.

- Precisely position the selected plant image in reference to the plan coordinates by specifying its **X Coordinate** and **Y Coordinate**.
- Specify the selected plant image's **Height Above Ground**.

Transparency Tab

The settings on the Transparency tab of this dialog are similar to those on the same tab of the **Image Specification** dialog. For more

information, see “Transparency Tab” on page 810.

Plant Information Tab

The settings on the Plant Information tab correspond to the search parameters in the **Plant Chooser**. See “Plant Chooser Dialog” on page 577.

 When multiple plants with differing attributes are selected, some button icons may be replaced by an X symbol, which signifies “No Change”.

Plant Description Tab

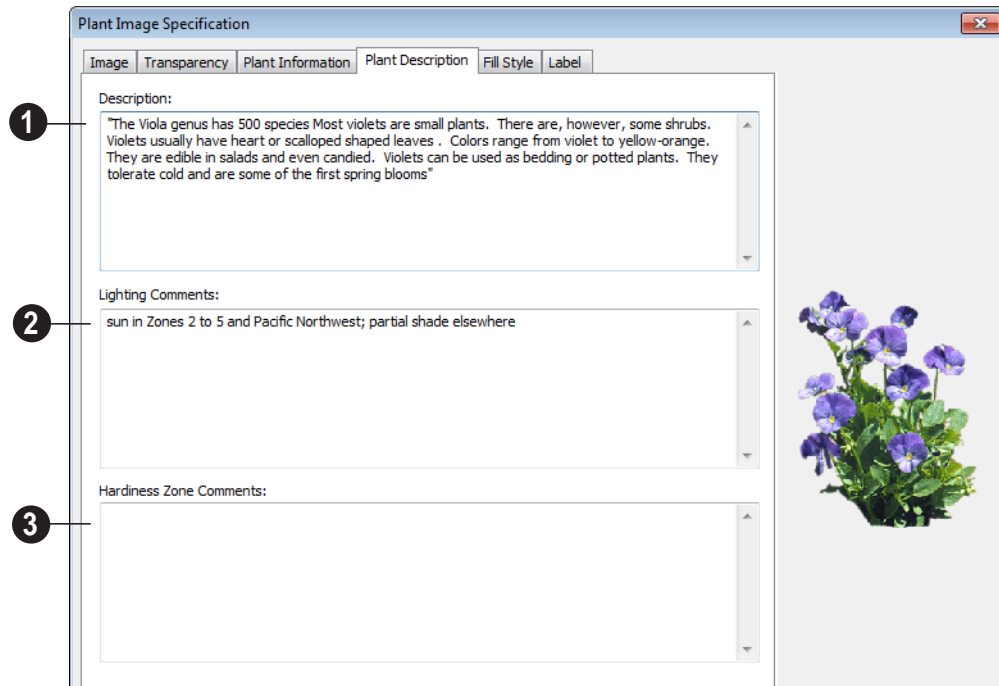

1 A detailed **Description** of the plant displays in this text field.

2 Information in the **Lighting Comments** fields describes the plant’s light requirements.

3 **Hardiness Zone Comments** are given here. See “Hardiness Zones” on page 579.

Fill Style Tab

The Fill Style tab controls the appearance of the selected plant’s 2D Plant Symbol in floor plan view. By default, plant images’ fill style

is None (Transparent). For information about the settings on this tab, see “Fill Style Tab” on page 792.

If the plant’s 2D Plan Symbol does not form a closed shape, the settings on the Fill Style tab will have no effect on the appearance of the plant in floor plan view.

Plant Chooser Dialog



Select **Terrain > Plant > Plant Chooser** to open the **Plant Chooser** dialog or click the button at the bottom of the Library Browser window.

Use the **Plant Chooser** to search the library for plant images and symbols that meet your search parameters. You can search using any or all of the options in this dialog.

The search parameters in the **Plant Chooser** dialog correspond to the settings on the Plant Information tab of the **Plant Image Specification** dialog. See “Plant Information Tab” on page 576.

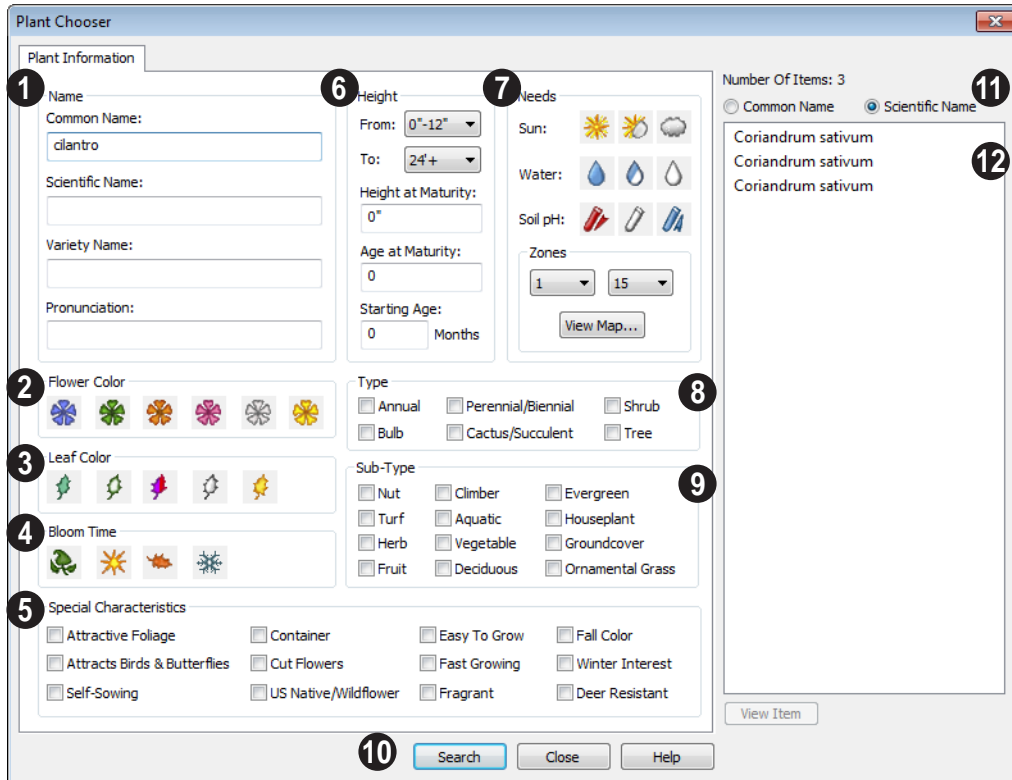

1 The **Common Name**, **Scientific Name** or **Variety Name** for the plant. A **Pronunciation** field is also provided.

2 Specify the **Flower Color** to search for here.

3 Specify the **Leaf Color** to search for here.

4 Specify the **Bloom Time** to search for, which is the season when the plant produces flowers.

5 Check one or more boxes to search for plants with **Special Characteristics**.

6 Specify the plant **Height** at maturity to search for. This is used with the Grow Plants feature. See “Plant Tools” on page 573.

- An average mature height range can be entered using the **From** and **To** drop-down lists.
 - A specific **Height at Maturity** to search for can be entered in the text field.
 - A specific **Age at Maturity**, in months, can be entered in the text field.
 - A specific **Starting Age**, in months, can be entered in the text field.
- 7 Specify the plant **Needs** to search for. These include the **Sun**, **Water**, **Soil pH**, and **Hardiness Zone** range. See “Hardiness Zones” on page 579.
 - 8 Check one or more boxes to indicate selected plant **Type** to search for.
 - 9 Check one or more boxes to specify the selected **Sub-Type** to search for.
 - 10 Click the **Search** button at the bottom of the dialog to search for plants that meet your search criteria. The search results display to the right.
 - 11 Specify whether you want the search results to use the **Common Name** or **Scientific Name**.
 - 12 Click on the name of a plant in the list to see its location in the Library Browser.
- If the selected plant has been downloaded, you can click the **View Item** button to see more information about it in the **Plant Information** dialog. See “Plant Image Specification Dialog” on page 574.

Hardiness Zones



Select **Terrain> Plant> Show Hardiness Zones** to view a selection

of regional **Hardiness Zone Maps**. Click the drop-down list to select various regions.

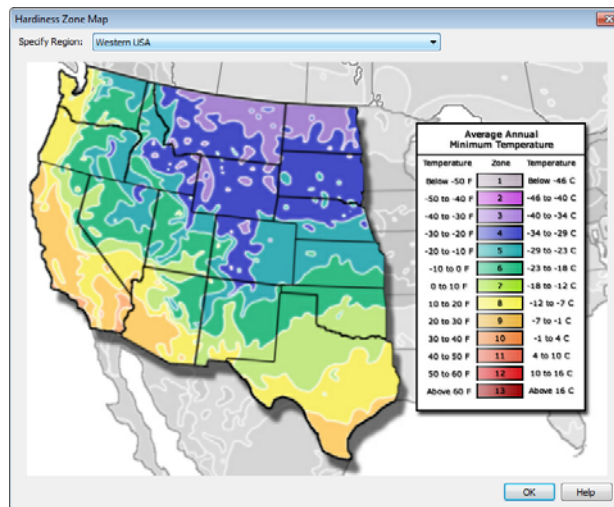

Sprinkler Tools



Use the **Sprinkler Tools** to design a sprinkler system in your plan.



Select **Terrain > Sprinkler > Sprinkler Head** to open the **Select Library Object** dialog. Browse to a sprinkler type in the library, click OK, then click in the drawing area to place as many as you need. Once drawn, sprinkler heads can be selected and edited. See “Sprinkler Specification Dialog” on page 580.



Select **Terrain > Sprinkler > Sprinkler Line** to draw sprinkler lines in your plan. Sprinkler lines are 2D objects and are drawn and edited much like CAD Lines. See “Line Tools” on page 776.



Select **Terrain > Sprinkler > Sprinkler Spline** to draw curved sprinkler lines in your plan. Sprinkler splines are 2D objects and are drawn and edited like CAD Splines. See “Splines” on page 796.

Displaying Sprinklers

The display of Sprinkler Heads, Lines and Splines can be controlled in the **Layer Display Options** dialog. See “Displaying Objects” on page 102.

In floor plan view, Sprinkler Head symbols indicate the spray angle.

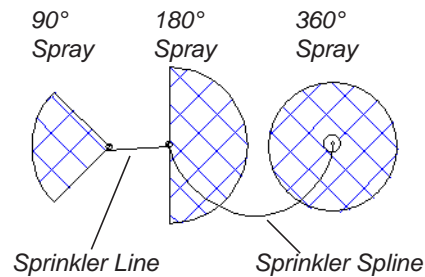

Unlike Sprinkler Heads, Sprinkler Lines and Splines do not display in 3D views. Their total length is calculated in the Materials List, however. See “Materials Lists” on page 887.

Sprinkler Specification Dialog



To open the **Sprinkler Specification** dialog, select a sprinkler or group of sprinklers and click the **Open Object** edit

button. You can also double-click the sprinkler(s) using the **Select Objects**  tool.

General Tab

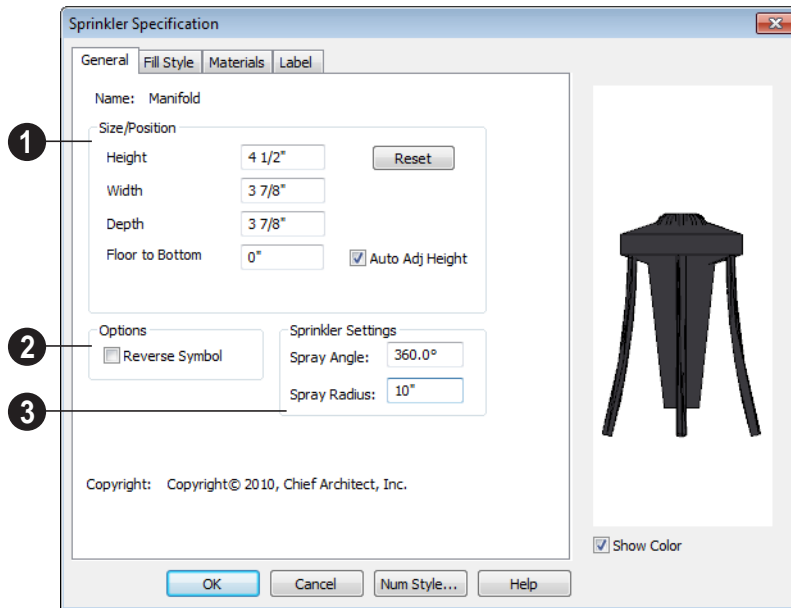

- 1 Specify the selected sprinkler's **Size/ Position**.
 - Enter the **Height**, **Width**, and **Depth** of the sprinkler.
 - Enter a **Floor to Bottom** value to define the distance from the bottom of the sprinkler to elevation 0 of Floor One.
 - Click the **Reset** button to return the sprinkler values to the defaults.
 - Uncheck **Auto Adjust Height** if you wish to specify an absolute Floor to Bottom height measured from the default floor height of Floor 1, rather than have the sprinkler follow the surface of the terrain. See "Terrain Height vs Floor Height" on page 539 of the Reference Manual.

Check **Auto Adjust Height** and enter a **Floor to Bottom** value to set sprinkler's

elevation relative to the terrain surface. For example, a value of -6" recesses the sprinkler head 6 inches below the surface of the terrain.



The elevation of a sprinkler can be edited in cross section/elevation views.

- 2 Check **Reverse Symbol** to reverse the sprinkler from left to right.
- 3 Set the sprinkler **Spray Angle** and **Spray Radius**.

Fill Style Tab

The Fill Style tab controls how the area within the sprinkler's reach displays in floor plan view and is similar to the Fill Style tab found in many dialogs. See "Fill Style Tab" on page 792.

Materials Tab

The Materials tab lets you control the appearance of the selected object in 3D views. For information about the settings on this tab, see “Materials Tab” on page 635.

Label Tab

Sprinkler labels display in floor plan view when the “Sprinklers, Labels” layer is turned on and use the Text Style assigned to that layer. For information about the settings on this tab, see “Label Tab” on page 531.

Roads, Driveways & Sidewalks

Roads and sidewalks are modeled in 3D like other terrain objects in Home Designer Pro. Because they have much in common with terrain objects and rely upon terrain data to be viewed in 3D, it is helpful to be familiar with terrain modeling before using these tools. See “Terrain” on page 537.

Chapter Contents

- Road, Driveway and Sidewalk Tools
- Displaying Road Objects
- Editing Road Objects
- Road Specification Dialog

Road, Driveway and Sidewalk Tools



Road objects can be drawn in floor plan view, camera views and overviews, but only when a Terrain Perimeter exists in the plan. See “Terrain Perimeter” on page 538.

Road objects created with the Road Tools have a consistent width that can be defined in their specification dialogs. See “Road Specification Dialog” on page 586, “Terrain Feature Specification Dialog” on page 562, and “Terrain Path Specification Dialog” on page 566.

Driveways and Parking Lots are actually Terrain Features. See “Terrain Feature Tools” on page 546. They are drawn as rectangles but can be edited to any shape. See “Editing Closed-Polyline Based Objects” on page 138.

Roads and sidewalks are flat along their widths, which makes it easy to create roads on sloping terrain. Driveways and Parking Lots follow the contours of the terrain rather than cut into them.



Once road objects have been placed, they can be edited individually or as a group. See “Editing Road Objects” on page 586.

Straight Road



To place a road without any curves, select **Terrain> Road> Straight Road** and click and drag to draw a line in floor plan view. The ends of multiple road sections can be connected together.

Roads are edited along their center line like CAD lines and polylines. See “Editing Line Based Objects” on page 127.

Spline Road



Use **Terrain> Road> Spline Road** to draw a curved road. Spline roads are drawn and edited like CAD splines. See “Splines” on page 796.

A driveway cuts out a curb wherever it meets a road.

Straight Sidewalk



To create a sidewalk with no curves, select **Terrain> Road and Sidewalk> Straight Sidewalk**, then click and drag from end to end to draw a line. The ends of multiple sidewalk sections can be connected together.

Sidewalks are edited along their center line like line- and polyline- based objects. See “Editing Line Based Objects” on page 127.

Sidewalks can be edited in their specification dialog. See “Terrain Path Specification Dialog” on page 566.



Spline Sidewalk



Use the **Spline Sidewalk** tool to create a curved sidewalk. Select **Terrain> Sidewalk> Spline Sidewalk**. Spline roads are drawn and edited like CAD splines. See “Splines” on page 796.

Driveway Area

A **Driveway Area** is a terrain feature with a concrete material assignment. To create a driveway, select **Terrain> Road and Sidewalk> Driveway Area**, then click and

drag from corner to corner to draw a rectangle. See “Polylines” on page 790.

Height, thickness and material information can be specified in a driveway’s specification dialog. See “Terrain Feature Specification Dialog” on page 562.

Driveways can be edited like other closed polylines. See “Editing Closed-Polyline Based Objects” on page 138.

Parking Lot



A **Parking Lot** is a terrain feature with an asphalt material assignment. To place a parking lot, select **Terrain> Road and Sidewalk> Parking Lot**, then click and drag from corner to corner to draw a rectangle. See “Polylines” on page 790.

Height, thickness and material information can be specified in a parking lot’s specification dialog. See “Terrain Feature Specification Dialog” on page 562.

Displaying Road Objects



Roads and sidewalks display in floor plan and 3D views based on the settings for their layers in the **Layer Display Options** dialog. See “Layers” on page 101.

In 3D Views

Road objects display in 3D views within the Terrain Perimeter. If the display of the Terrain Perimeter is turned off in 3D views, roads and sidewalks will not display, either: even if their layers are turned on.

By default, terrain rebuilds automatically when road objects are added, removed or edited. If it does not, you can select **Terrain>**





Build Terrain . See “Terrain Perimeter” on page 538.



Editing Road Objects

Road objects can be selected individually and as a group in 2D and 3D views and edited using the edit handles, the edit toolbar and their specification dialogs.

Using the Mouse

The edit handles available for a selected road object depend on the type of object selected.

- **Straight Roads**  and **Straight Sidewalks**  are edited along their centerline like a line or open polyline. See “Editing Line Based Objects” on page 127.
- **Spline Roads**  and **Spline Sidewalks**  are edited along their centerline like CAD splines. See “Splines” on page 796.

- **Driveway Areas**  and **Parking Lots**  are edited like other closed polyline based objects. See “Editing Closed-Polyline Based Objects” on page 138.

In the Specification Dialog

Road objects can be customized in their specification dialogs. See “Road Specification Dialog” on page 586, “Terrain Feature Specification Dialog” on page 562, and “Terrain Path Specification Dialog” on page 566.

Using the Edit Tools

A selected road object can be edited in a variety of ways using the buttons on the edit toolbar. See “The Edit Toolbar” on page 29.

Road Specification Dialog

To open the **Road Specification** dialog, select a Straight Road or Spline Road and click the **Open Object** edit button.

Many of the settings in this dialog are similar to those in the **Terrain Path Specification** dialog.

General Tab

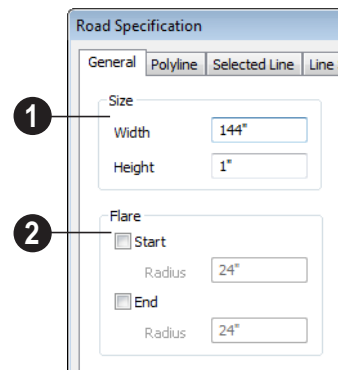

- 1 Specify the **Width** and **Height** of the road relative to the terrain.
- 2 **Flare** - Roads can be flared at the **Start** and the **End** when they intersect with other road objects. Check one or both boxes.
 - **Radius** - Enter the flare radius.

Polyline Tab

The Polyline tab lists the length of the road's Perimeter, Area and Volume. For more information, see "Polyline Tab" on page 792.

Selected Line/Arc Tab

The Selected Line tab is available when a Straight Road is selected. For more information, see "Line Tab" on page 780.

The Selected Arc tab is available when the curved segment of a Straight Road is selected. See "Arc Tab" on page 787.

Spline Tab

The Spline tab is available when a Spline Road is selected. Specify the angle between the line segments used to draw the spline.

For more information, see "Spline Tab" on page 792.

Line Style Tab

This tab is the same as the Line Style tab in many other specification dialogs. See "Line Style Tab" on page 781.

Fill Style Tab

The settings on the Fill Style tab affect the appearance of the selected object in floor plan view. For information about these settings, see "Fill Style Tab" on page 792.

Materials Tab

The settings on the Materials tab affect the appearance of the selected object in 3D views. For information about these settings, see "Materials Tab" on page 635.

The material selected here is not calculated in the Materials List. See "Materials Lists" on page 887.

Other Objects

Home Designer Pro has additional objects that can be used to customize your design.

Chapter Contents

- General Shapes
- Soffits
- Special Applications for Soffits
- Calculating Materials on Soffits
- Soffit Specification Dialog

General Shapes

Items in the Home Designer Core Catalogs> Shapes library catalog allow you to create a variety of custom objects using basic geometric shapes. These shapes can be

used individually or combined to create a wide variety of custom objects.

General Shape objects are placed and edited much like other library objects. See “Editing Box-Based Objects” on page 141.

Soffits



Soffits typically fill the space between the tops of wall cabinets and the ceiling, but they are very versatile and can be used to create almost any other object that can be modeled as a 3D box. Select **Build> Cabinet> Soffit** to activate this tool.

Soffit Defaults

The default settings for soffits are set in the **Soffit Defaults** dialog. The settings in this dialog are similar to those in the **Soffit Specification** dialog. See “Soffit Specification Dialog” on page 592.

For best results when placing soffits above wall cabinets:

- The default soffit should be the same width as and 1" (20mm) deeper than the default wall cabinet. See "Cabinet Defaults" on page 507.
- The default soffit **Floor to Bottom** value should equal the sum of the default wall cabinet's Floor to Bottom value plus its Height. See "General Tab" on page 593.
- The default soffit **Height** should be equal to or greater than the space between the ceiling and the top of the wall cabinets.

If the sum of the default soffit's Floor to Bottom value and Height is larger than the ceiling height of the room in which a soffit is placed, the Floor to Bottom value will be retained and its Height will be adjusted so that it fits under the ceiling.

The maximum soffit width is 250 feet (48m), and the minimum width is 1/16" (1 mm).

Once a soffit is placed in a plan, you can change its size and position to meet a variety of needs.

Placing Soffits

Soffits can be created in both 2D and 3D views by simply clicking with the **Soffit**  tool active. See "Click-to-Create" on page 113.

They can be assigned materials that are calculated in the Materials List, but by default they use the material assigned to the default wall. See "Wall, Railing, and Fencing Defaults" on page 176.

When positioned against a wall in a room, soffits will display any moldings present in that room that are at the same height as the soffit. See "Moldings Tab" on page 250.

Like cabinets, soffits can also have custom molding profiles specified. See "Moldings Tab" on page 531.

To create a corner soffit, click as close to an inside wall corner as possible. A corner soffit retains its shape when it is moved, edited, or copied.

When a soffit is created, it is placed on the "Cabinets, Soffits" layer. See "Displaying Objects" on page 102.

Special Applications for Soffits

Nearly any object with straight, flat sides can be represented by one or more Soffits. They can be resized to as small as 1/16" (1mm) per side, or as large as 250 feet (48m).

Soffits can have materials applied to them to represent simple mirrors, posts, chimneys and so on. Following are some additional examples.

Roof Beams and Cofferred Ceilings

Sloped soffits can be used to represent beams or rafters that follow the pitch of the roof in rooms with cathedral ceilings. See "Sloped Soffits" on page 594.



Soffits can also be used to create coffered ceilings. When placed against a wall, a soffit will display any moldings assigned to the room it is in that are at its height. In addition, you can assign moldings directly to a soffit in its specification dialog. See “Moldings Tab” on page 594.



Accent Tiles

A material such as ceramic tile can be assigned to one or more soffits applied to the walls above tubs or in showers.



Masonry Veneer

As an alternative to a pony wall, you can use a soffit to create a brick or stone veneer over part of a wall. Specify a soffit depth equal to the masonry material to be used.

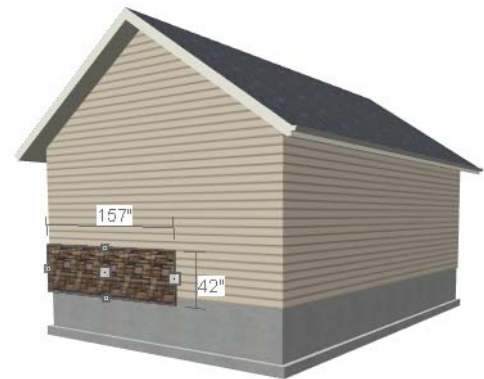

Soffits automatically stop at the floor platform when moved downward or at the ceiling platform when moved upward - even when the soffit is not located in a room. To move or resize a soffit through a floor or

ceiling platform, select it and hold the Ctrl key down while dragging its edit handles. See “Unrestricted Movement” on page 153.

Calculating Materials on Soffits

The number of bricks, tiles, shingles, shakes or other materials applied to a soffit is calculated using the following rules:

- If the soffit depth is less than the larger of 4 inches (10 mm) or 1 ½ times the material thickness, then only the front area of the soffit is used. Thus if a soffit is 48"x48"x4" thick, and the Dark Red brick material is used (3"x 8" with 3/8" mortar joint) the front of the soffit is 48"x48"=2304 square inches. Including the mortar joint, each brick requires $3 \frac{3}{8}'' \times 8 \frac{3}{8}'' = 28.26$ square inches. 2304 sq. in. divided by 28.26 sq. in. per brick gives 81.5 bricks.
- If the soffit depth is greater than both 4 inches (10 mm) and 1 ½ times the material thickness, then the surface areas of the soffit back, sides and top are used in addition to the front, if these surfaces are not attached to a wall or other soffit. However, only those portions of the sides, top and bottom remaining after

subtracting twice the material thickness are used. So, for Dark Red brick, which has a depth of 4", the sides, top and bottom surface areas cannot contribute to the brick count unless the soffit depth is greater than 8 inches.

- If surface materials such as brick are applied to a large soffit, the soffit center is assumed to be hollow, with only a single layer of the material applied to each applicable face.
- For shingles and shakes, the overlap amount should be subtracted from the height, as opposed to brick or tile, where the joint width is added to the size.
- For materials in the area category, the soffit area calculation above is used, with the material thickness treated as zero.
- For materials in the volume, concrete or earth categories, the true volume of the soffit is used.

Soffit Specification Dialog



To customize a soffit using the **Soffit Specification** dialog, double-click on the soffit using the **Soffit**  tool or select the soffit and click the **Open Object** edit button.

The settings in this dialog are similar to those in the **Soffit Defaults** dialog, but affect only the selected object(s).

General Tab

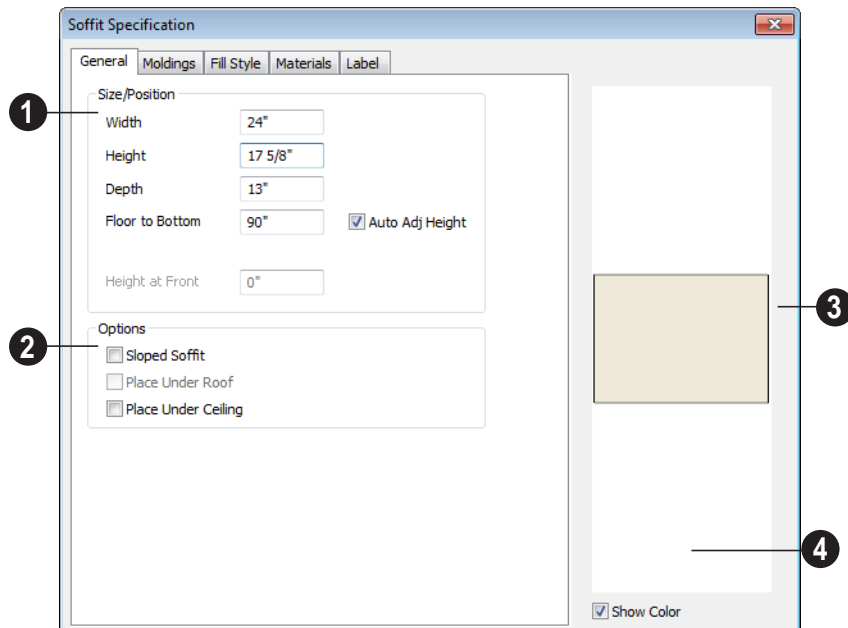

- 1 Define the **Size** and **Position** of the selected soffit relative to the floor or terrain.
 - Specify the **Width** of the soffit.
 - Define the vertical **Height** of the soffit.
 - **Depth** - Define the distance between the front and the back of the soffit. When selected in floor plan view, the front of a soffit has a “V,” and the back of the soffit has a triangular rotation handle.
 - If the selected soffit is a corner soffit, the **Width** controls its left side width, and **Depth** controls its right side width.
 - **Floor to Bottom** - Specify the distance from the bottom of the soffit to the floor. This is sometimes more easily done by positioning the soffit in a 3D view.

- **Height at Front** applies to sloped soffits and becomes enabled when Sloped Soffit is checked. See “Sloped Soffits” on page 594.
 - When the selected soffit is outside a room and **Auto Adjust Height** is checked, its Floor to Bottom height is measured relative to the terrain height. When this is unchecked, the Floor to Bottom height is measured from the default floor height of Floor 1. See “Terrain Height vs Floor Height” on page 539 of the Reference Manual.
- 2 **Options** - Specify a sloped soffit and/or position relative to the roof or ceiling.
 - Check **Sloped Soffit** to slope the soffit vertically from the back up towards the front. When you specify a soffit as

sloped, the options on the General tab change. See “Sloped Soffits” on page 594.

- Check **Place Under Roof** to have the soffit’s slope follow that of the roof. The soffit moves up and the top of the soffit is in the same plane as the roof, at the same pitch as the roof. Be sure to place the front of the soffit toward the high side of the roof. Only available when **Sloped Soffit** is checked. Not available in the **Soffit Defaults** dialog.
 - Check **Place Under Ceiling** to move the soffit vertically until the top contacts the ceiling plane. Not available in the **Soffit Defaults** dialog.
- 3 A preview of the soffit displays on the right side of the dialog box.
 - 4 Check **Show Color** to display the soffit’s material in the preview.

Moldings Tab

For information about the settings on this tab, see “Moldings Tab” on page 531.

Sloped Soffits

When a soffit is specified as a sloped soffit, the options on the General tab of the **Soffit Specification** dialog change.

Fill Style Tab

The settings on the fill style tab affect the selected soffit’s appearance in floor plan view. For information about the settings on this tab, see “Fill Style Tab” on page 792.

Materials Tab

For information about the settings on this tab, see “Materials Tab” on page 635.

Label Tab

Soffit labels display in floor plan view when the “Cabinets, Labels” layer is turned on and use the Text Style assigned to that layer. The Automatic Label for Soffits is blank, but you can specify a custom label. See “Cabinet Labels” on page 515.

For more information about the settings on this tab, see “Label Tab” on page 885.

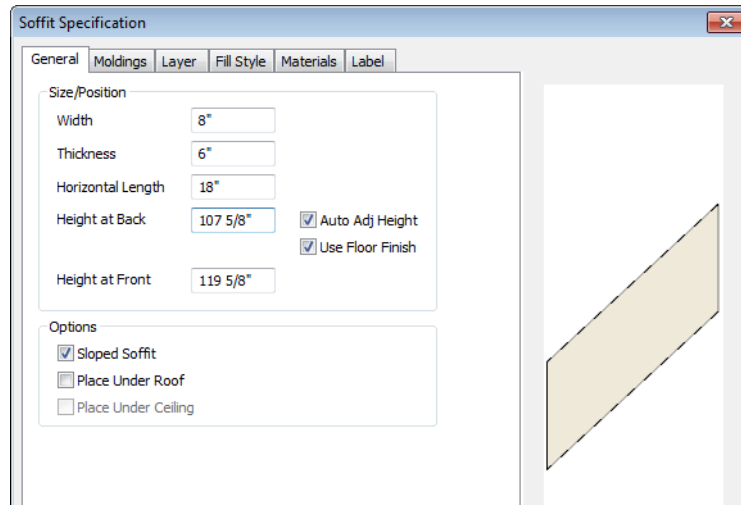

- **Width** is measured left to right across the soffit, parallel to the front of the soffit.
 - **Thickness** is measured perpendicular to the slope of the soffit.
 - **Horizontal Length** is measured from back to front in floor plan view. Since the soffit is sloped, this measurement is not the actual length of the soffit. It cannot, for example, be used to determine the length of a sloped beam.
- Both the front and back heights of a sloped soffit must be defined.
- **Height at Back** is measured from the finished floor to the lowest point at the back of the soffit.
 - **Height at Front** is measured from the finished floor to the underside of the soffit at the upper end.

Architectural Blocks

An architectural block is a collection of individual 3D objects that are grouped together so that they can be placed and moved as a single object. Although blocked together, these objects retain many of their own attributes, such as materials.

Architectural blocks can also be exploded so that the individual sub-objects become independent of one another.

Chapter Contents

- Creating Architectural Blocks

Creating Architectural Blocks



An architectural block is created by group-selecting multiple architectural objects and then clicking the **Make Architectural Block** edit button.

The following is a list of objects that can be included in architectural blocks:

- Cabinets (Base, Wall, Full Height)
- Soffits, Shelves, Partitions
- Fixture/Furniture Symbols
- Hardware Symbols
- Millwork Symbols

- Geometric Shape Symbols
- Electrical objects
- Images
- Custom Countertops
- Slabs & Foundation Slabs
- Roads, Driveways, Sidewalks
- Terrain Features and Terrain Modifiers

Once blocked, the set of blocked objects is contained in a bounding box, indicating that they are now an architectural block.

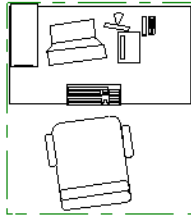

Architectural blocks can be created in any view.

Displaying Architectural Blocks

Architectural blocks are placed on the “Architectural Blocks” layer and can be displayed in all views. The display of architectural blocks, including their bounding box, is controlled in the **Layer Display Options** dialog. See “Displaying Objects” on page 102.

You can select an architectural block and click the **Move to Front**  edit button to make that block display in front of other objects in the same drawing group, including

cabinets and some library symbols. See “Move to Front of Group” on page 151.

Architectural Block Labels

In floor plan view, architectural blocks can display labels for both the block and any component objects that have labels. Labels for architectural blocks are placed on the “Architectural Blocks, Labels” layer and use the Text Style assigned to that layer. See “Object Labels” on page 884.

Editing Architectural Blocks

Architectural blocks can be selected and edited in 2D and 3D views. See “Selecting Objects” on page 124.

Note: Moving an architectural block in 3D view regenerates the view. If the architectural block contains terrain objects, the terrain is rebuilt.

Once selected, an architectural block can be edited using its edit handles and edit toolbar buttons.

Using the Edit Handles

A selected architectural block displays a Move handle and a Rotate handle.

Architectural blocks cannot be resized, but the individual objects in the block can be.

Using the Edit Tools

A selected architectural block or blocks can be edited in a variety of ways using the buttons on the edit toolbar. See “The Edit Toolbar” on page 29.

Editing Sub-Objects

The individual objects included in an architectural block can also be selected and edited. See “To select a sub-object” on page 600.

Explode Architectural Block



You can break an architectural block to make its objects independent.

Select the architectural block and click the **Explode Architectural Block** edit button.

Note: If you open a plan created in another version of Home Designer and an architectural block includes an object that you cannot create in your version of the software, you cannot unblock it or edit its components.

Once exploded, an architectural block cannot be made into a single object again.



Architectural Blocks, Sub-Objects, and Components

An architectural block is composed of a group of sub-objects that have been blocked together. For example, a kitchen island architectural block may consist of cabinets, appliances, a custom countertop, and other accessories.



Each of the sub-objects in an architectural block may contain additional parts called components. The cabinets in a kitchen island, for example, may contain handles, hinges, and drawer glide.

Sub-Objects

Certain attributes of an architectural block can be edited at the sub-object level. A sub-object can be edited by accessing its specification dialog in either of two ways:

- Explode the architectural block, select the sub-object, and click the **Open Object**  edit button.
- Select the sub-object while it is part of the architectural block and click the **Open Object**  edit button. Some attributes may not be editable while the object is part of a block. See “Editing Architectural Blocks” on page 599.

To select a sub-object

1. Click the **Select Objects**  button, then click on the sub-object that you would like to edit.
2. With the architectural block selected, click the **Select Next Object**  edit button or press the Tab key.

The selection switches to the individual object and it can be edited using its edit handles, edit toolbar and specification dialog.

The ability to edit an object as part of a block may be more restricted than if the object were independent. If more extensive editing is required, the architectural block must be exploded.

Components

 You can view and/or modify the components of an architectural block (or group of blocks) through the **Components** dialog. The **Components** dialog lists all the sub-objects that comprise an architectural block, as well as the components that make up each sub-object.

To open the **Components** dialog, select an architectural block and click the

Components  edit button. See
“Components Dialog” on page 901.

The Library

Home Designer Pro's library offers thousands of symbols, materials, and images that can enhance any plan.

New library catalogs and enhancements are made available by Chief Architect on a continuing basis and are available for download for the current program version.

You can also customize items from the library or import new items from outside the program and then save them in the library for future use.

Chapter Contents



- The Library Browser
- Searching the Library
- Library Content
- Downloading Library Content
- Importing Library Catalogs
- Adding Library Content
- Organizing the Library
- Filtering the Display of Library Content
- Exporting Library Catalogs
- Placing Library Objects
- Select Library Object Dialog
- Replace From Library
- Displaying Library Objects
- Editing Library Objects
- Symbol Object Specification Dialogs

The Library Browser



The Home Designer Pro Library Browser allows you to manage the contents of the library as well as add library content to your drawings.

To open the Library Browser:

- Select **Library > Library Browser** .
- Click the **Library Browser** button .
- Press **Ctrl + L** on your keyboard.

By default, the Library Browser is docked to the right side of the program window, but can be undocked or docked to another side. See “Docking the Library Browser” on page 608.

The Library Browser has four sections:

- The search options at the top.

- The Directory and Search Results Pane.
- The Selection Pane.
- The Preview Pane.

To adjust the height or width of a section, place the pointer over the split bar you want to move. When the double-headed arrow ↔ displays, click and drag.



You can control the configuration of the Library Browser panes in the Preferences dialog. See “Library Browser Panel” on page 65.

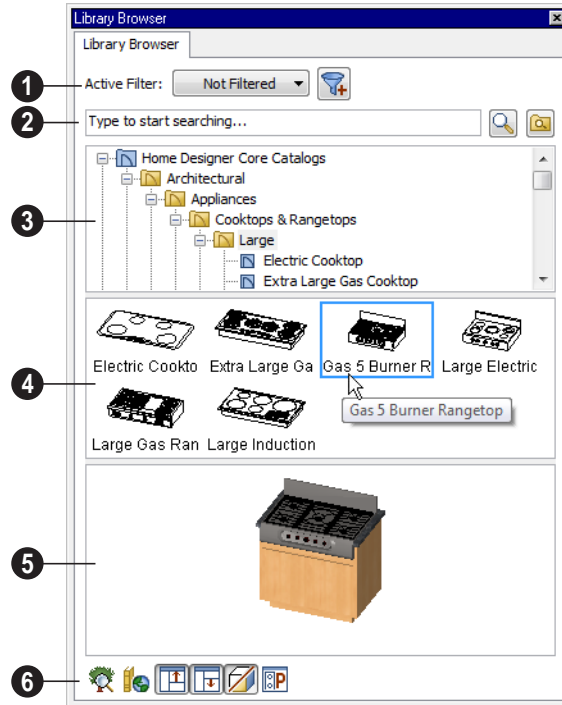

You can work on your drawing with the Library Browser open. To close the Browser, click the Close  button or double-click on an object in the Selection Pane.





The library has five categories: Home Designer Core Catalogs, Home Designer Bonus Catalogs, Manufacturer Catalogs, User Catalog and Trash. See “Library Content” on page 609.

- 1 Specify what displays in the Directory Pane’s tree list by selecting a filter from the drop-down list. See “Filtering the Display of Library Content” on page 618.
- When “Not Filtered” is selected, all installed library content will display in the tree list.
- “Not Filtered” will be the only available option until you create a custom filter.
- Click the **Manage Library Filters**  button to open the **Manage Library**

Filters dialog. See “Manage Library Filters Dialog” on page 619.

- 1 Search the library using keywords and optional search filters. See “Searching the Library” on page 608.
- Begin typing in the text field to search for library items. As you type, search results will display in the Directory Pane.
 - Right-click on an item in the Search Results list and select **Show in Browser** to view the item’s location in the Directory list.
 - Click the **Browse**  button to stop searching and restore the Directory list.
 - Click the **Search**  button to display the search results for your search entry.

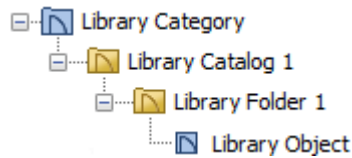

- Click the **Turn On Search Filtering**  button to display the search filtering options and customize your search parameters.
- Click the **Turn Off Search Filtering**  button to display the search filtering options and customize your search parameters.

3 The library **Directory** and **Search Results** display here. The basic structure of the directory tree is:



Library items are always placed in alphabetical order within their hierarchy.

The Library Browser includes a Trash bin, where deleted items are moved until you choose to Empty Trash. See “Deleting Library Items” on page 617.

Navigate the Directory Pane using the mouse. Click the  beside a catalog or folder to display its contents. Once expanded, you can click the  beside it to close it again. You can also scroll the list using the arrow keys on your keyboard.

Click on an item to select it. Preview images display in the Selection and Preview Panes and basic information about it also displays in the program’s Status Bar. See “The Status Bar” on page 31.

4 The **Selection Pane** shows a thumbnail image of the item selected in the Directory Pane.

When an item is selected in the Directory Pane, a basic line-based representation of the item displays in the Selection Pane.

- If the selected item is a single object, a preview of that object displays in the Preview Pane. You can move your cursor into the drawing area to place the item. See “Placing Library Objects” on page 620.
- If the selected item is a folder, a thumbnail image displays, representing each item inside. Move your pointer over an item in this pane to see a Tool Tip with the item’s name. Click on a folder in the Selection Pane to display its contents here and make it the item selected in the Directory Pane.
- Some folders may have too many items to display useful thumbnails for each; when this is the case, they do not display.

If you have **Scrollable List** checked in the **Preferences** dialog, a scroll bar is present at the bottom of the Selection Pane.

Click the **Show/Hide Selection Pane**  button to toggle the Selection Pane on and off.

5 When an individual object is selected in either the Directory or Selection Pane, an image of it displays in the **Preview Pane**.

You can click the **Toggle Display**  button at the bottom of the browser window to switch between preview images in Standard Render and Vector View styles.

If the selected object is a 3D symbol, you can rotate and zoom in or out on the Preview using the mouse.

If you have rotated a view in the Preview Pane, you can restore the default angle either by clicking in the Selection Pane or by right-clicking on the Preview Pane and selecting **Reset Preview**.

Click the **Show/Hide Preview Pane**  button to toggle the Preview Pane on and off.

6 The toolbar at the bottom of the browser aids in searching, displaying panes, and managing library content.

 Click the **Plant Chooser** button to open the **Plant Chooser** dialog. See “Plant Chooser Dialog” on page 577.

 Click the **Get Additional Online Content** button to launch your default web browser to the Home Designer Pro web site, where additional library content is available for download.

 Click the **Show/Hide Selection Pane** button to toggle the Selection Pane on and off.

 Click the **Show/Hide Preview Pane** button to toggle the Preview Pane on and off.

 Click the **Toggle Display** button to switch between Standard Render and Vector View images of a selected library object in the Preview Pane. See “Rendered and Vector Views” on page 665.

 Click the **Preferences** button at the bottom of the Library Browser to open the **Preferences** dialog, where display properties for the Library Browser can be controlled. See “Library Browser Panel” on page 65.

Using the Contextual Menus

A number of important library functions can be accessed using the contextual menus. Right-click on an item in the Library Browser to open a contextual menu displaying options related to that item. See Contextual Menus.

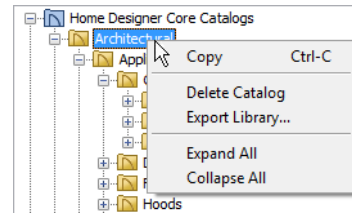

The options in the contextual menu vary depending on the item selected, but may include:

- Cut/Copy/Paste
- Paste Shortcut
- Rename
- Delete
- Export Library
- Open
- Components
- Reset Preview
- Expand All/Collapse All
- Show in Browser

Keyboard Commands

The Library Browser can be navigated using the arrow keys on your keyboard.

- The right and left arrow keys expand and collapse folders.
- The up and down keys change which library object is currently selected.

- Select an item and press F2 to rename it.
- Select an item and press the Delete key to delete it.

If you have **Scrollable List** selected in the **Preferences** dialog, pressing the Tab key switches focus between the Directory and Selection Panes. Use your mouse to select an object for placement. See “Library Browser Panel” on page 65.

If you have **Tiled To Fit Window** selected instead, pressing the Tab key switches focus between the tree view and the Selection Pane. You can then use the arrow keys to select a library object within the Selection Pane.

Expand/Collapse All

When a library category or folder is selected in the Directory Pane, **Expand All** and **Collapse All** are available in the contextual menu, allowing you to expand or contract its contents in the tree view.

Docking the Library Browser

Initially, the Library Browser is docked to the right side of the Home Designer Pro program window.

To undock the browser window, double-click the striped grab bar. You can also undock it by clicking on the grab bar and dragging it into the center of the program window.

Once undocked, the Library Browser can be moved by clicking and dragging the title bar.



When moved to the top, bottom, or side of your screen, it automatically docks in a vertical or horizontal orientation, depending on its location.

- **Disable Docking** in the **Preferences** dialog prevents the Library Browser from docking to the side of the screen. See “Library Browser Panel” on page 65.
- Holding down the **Ctrl** key prevents the Library Browser from docking while moving.
- If you close the program with the Library Browser docked, it displays in the same position the next time the program is opened.

To return the browser window to its original position and size, click the **Restore Position/Size** button on the Library Browser Panel of the **Preferences** dialog.

Closing the Library Browser

The Library Browser can be closed in either of two ways:

- Click the **Close**  button at the top right corner of the browser window.
- Select **Library > Close Library Browser** .

Searching the Library

The Library Browser filtering options let you focus your searches to meet parameters that you define.



To search the Library Browser

1. Select **Library> Library Browser**  and click in the Search field at the top of the Library Browser.
2. Begin typing a keyword to search for.
3. As you type, the search results will populate in the Directory Pane below.
4. If you move your mouse pointer over the Search field, a Tool Tip will state the number of results of your search.
5. Right-click on an item in the Search Results list and select **Show in Browser** to view the item's location in the Directory list.

Substrings are not included. For example, searching for “windows” will not produce “window” as a search result. On the other hand, searching for “window” will produce “windows” as a search result.

To search using custom filters

1. Click the **Turn on search filtering options**  button.
 - Check **Match Keyword** to match the entered search keyword with an object's search attributes.
 - Check **Match Entire Word** to match the entire keyword or words with the complete name of the object.

- Check **Match Folders** to include library folders in your search.
2. Check **Filter by** to enable additional filtering options, which display below.
 3. Select a filtering option from the drop-down list on the left, then choose what to include in the filter from the drop-down list on the right:
 - Select **Type**, then select a category of library item to include in your search.
 - Select **Style**, then choose a design style to restrict the search results to objects of that style.
 - Select **Manufacturer**, then choose the name of a manufacturer to include in your search. Manufacturer catalogs that were imported during the current program session will not be listed until you exit out of and restart Home Designer Pro.
 4. Multiple filters can be created and used at the same time:
 - Click the **Add**  button to the right of a filter to make copy of that filter.
 - Specify a new **Type**, **Style**, and/or **Manufacturer** for the new filter.
 - Click the **Delete**  button to the right of a filter to remove that filter.

Note: Your custom search settings are not retained when you end the current program session.

Library Content

The Home Designer Pro library has five categories: Home Designer Core Catalogs, Home Designer Bonus Catalogs,

Manufacturer Catalogs, User Catalog and Trash. See Getting Started Guide, “Deleting Library Items” on page 617.

Home Designer Core Catalogs

The Home Designer Core Catalogs category contains a wide selection of 3D symbols, images, and materials. When you install the program from DVD, this library content will also be installed; if you download the software, you will be able to download the Core Catalogs separately, after the program is installed.

When you launch the program for the first time, it will ask if you want to download the Core Catalogs. Click Yes to begin the download. If you click No, you can download at any time by selecting **Library> Install Core Content** from the menu.

Home Designer Bonus Catalogs

Chief Architect regularly posts new library catalogs available for download. Select **Library> Get Additional Content**

Online  from the menu to access the bonus catalogs and content.

Manufacturer Catalogs

A variety of name brand library catalogs are available for download on the Home Designer web site with content ranging from materials to fixtures.

Select **Library> Get Additional Content**

Online  to access these Manufacturer Catalogs.

The User Catalog

The User Catalog is the location for items that you add to the library either from a

drawing or by importing. See “Adding Library Content” on page 613.

You can create and organize custom library folders and imported items such as symbols, images, backdrops, and materials. See “Organizing the Library” on page 615.

Updating Library Catalogs

The Home Designer Core Catalogs, Bonus Catalogs, and Manufacturer Catalogs are updated periodically to include new and improved content. You can update your installed catalogs to include the latest content by selecting **Library> Update Library Catalogs** at any time.

The program will gather information about the content in each of these three categories, and then download and replace any content that is not up to date, and you may see a progress indicator at the bottom of the Library Browser while it is doing so. See “Download Progress” on page 611.

Backing up Library Content

The Home Designer Pro User Catalog File, `User_Library.calib`, is located in the Home Designer Pro 2014 Data folder. See “Home Designer Pro Data” on page 41.

The best way to back up your custom library content is to export the items in your User Catalog, as this will ensure that the textures used by custom materials or imported symbols are not lost. See “Backing Up Your Files” on page 45.

Exported libraries use the `.calibz` file format: a zipped file type that can include textures and images along with other library data.

To back up your custom library content

1. Launch Home Designer Pro and select **Library> Library Browser**  from the menu.
2. Right-click on a folder or item in the User Catalog.

3. Select **Export Library** from the contextual menu.
4. The **Export Library Data** dialog is a typical Save dialog. See “Exporting Files” on page 45.
 - Notice that the file type in the Save as type field is “Library File with Textures/Images (*.calibz)”.

Downloading Library Content

The Home Designer Core Catalogs, Home Designer Bonus Catalogs, Manufacturer Catalogs are all available for internet download.

Core Catalogs

When you launch Home Designer Pro for the first time, you will be asked if you want to download the Core Catalogs. Click Yes to begin the download.

If you click No, you can download at any time by selecting **Library> Install Core Content** from the menu.

Bonus and Manufacturer Catalogs

Bonus and Manufacturer Catalogs can be downloaded from our web site, www.homedesignersoftware.com. Select **Library> Get Additional Content**

Online  to launch your default internet browser to our Content Resources page.

Download Progress

When library content is downloading, a green progress bar will display at the bottom

of the Library Browser. If you choose to download the Core Catalogs while the library is not open, the Browser will open so the progress indicator can display.

Click on the progress bar to display the name of the current file being downloaded, the total amount of data to be downloaded in KB, and the amount downloaded so far.

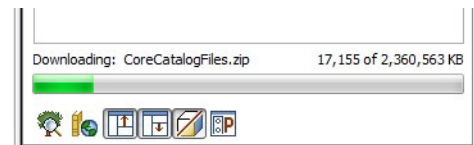

Pausing and Resuming

Library downloads can only take place while Home Designer Pro is running. If you close the program while a download is in progress, a dialog will confirm whether you wish to stop the download.

- Click **Stop Download and Close Program** to stop the download and close the program.
- Click **Cancel** to leave the program open and continue downloading.

Most catalogs are composed of a single file. If you stop the download midway, none of the downloaded data will be retained.

The Core Catalogs, on the other hand, contain a large volume of data saved in multiple files. If you close the program and stop the Core Catalogs download midway, only data associated with the file currently being downloaded will be lost. You can resume the download beginning with that file

at a later time by selecting **Library> Install Core Content**.

Download Errors

If any problems occur during the library download process, a dialog box will notify you at the end of the download. Click **Retry Download** to repeat the download and correct any errors or click **Cancel** to discard the downloaded catalog.

Importing Library Catalogs

Home Designer Pro library files have two different file extensions: **.calib** and **.calibz**. Both files can include any combination of Home Designer Pro library items; in addition, **.calibz** files are able to save data associated with textures and images. Both file types can be imported into the Home Designer Pro library.

There are several ways to import a **.calib** or **.calibz** file into the program library:

- Double-click on the file in Windows Explorer.
- Drag the file from a Windows Explorer window and drop it into the Home Designer Pro program window.
- Select **Library> Import Library** from the program menu.

To import library files into the library

1. Select **Library> Import Library** to display the **Import Library Data** dialog.
2. Browse to the **.calib** or **.calibz** file(s) that you want to import and either single

or group-select the files so that their names display in the **File Name** field.

- To select a group of files, click on the first one, hold down the Shift key, then click on another file. The two files plus all files in between are selected.
 - To select multiple files individually, click on one, hold down the Ctrl key, then click on additional files. Only the files you click on are selected.
 - To select all files in the directory, click on one and press Ctrl + A. Only do this if you wish to import all files in the folder.
3. Click the **Open** button.
 4. A progress bar will display, telling you the progress of each library data file as it is imported. Once imported, each file will be located in the User Catalog.

When a **.calib** or **.calibz** file is imported into the program, its contents are automatically placed in the User Catalog. Any images or textures saved in a **.calibz** file will be copied into the Home Designer Pro 2014 Data\Images and Textures folders for backup purposes. The program will only reference

these copies if it cannot locate the files in their original locations. See “Home Designer Pro Data” on page 41.

Legacy Library Conversion

You can import **.calib** and **.calibz** files created in Home Designer versions 2012, 10, or 9 for use in version 2014 at any time. See “Exporting Library Catalogs” on page 620.

In addition, legacy **.alb** files created in Home Designer versions 8.0 and prior can be converted for use in version 2014.

To convert legacy library files

1. Select **Library > Convert Legacy (.alb) Library Files**.
2. In the **Select a Legacy Library File Folder** dialog, select one or more **.alb** files that you want to bring in to Home Designer Pro 2014.
3. The selected files’ names will display in the **File name:** field.

4. Click the **Open** button to import these prior version third party **.alb** files into the User Catalog.
5. Organize the imported content to suit your needs. See “Organizing the Library” on page 615.

Note: Library content exported from Home Designer Pro 2012 will not include catalog names. Any subscribed content that has not been downloaded will not be included, either.

Third Party Library Content

There are a variety of third party sources for 3D symbols, textures and other items that may be of use in Home Designer Pro. Some sources even provide this content in **.alb** file format, which was the library file format used by Home Designer Pro versions 8.0 through X1. These third party libraries can be converted for use in Home Designer Pro 2014 as described above.

Adding Library Content

In addition to downloading Home Designer Pro Content and importing entire catalogs into the library, you can also add a variety of individual objects to the library.

Add to Library

Nearly any object imported into a plan or placed from the Library Browser can be added to the User Catalog in the library.

- Check **Add to Library** in the **Import 3D Symbol** dialog. See “Importing 3D Symbols” on page 838.

- Select an object in your plan and click the **Add to Library**  edit button.

In addition, some Home Designer Pro objects that are not symbols, such as cabinets, terrain objects, architectural blocks, windows, and doorways can be added to the library. See “Native Objects vs Symbols” on page 626.

An object created using a drawing tool in Home Designer Pro will automatically be added to the User Catalog using the name of that tool, whereas a symbol imported will

automatically use the Symbol Name. These objects can be renamed after adding them to the Library, either before or after moving them to their appropriate user created folder in the User Catalog. See “Renaming Library Items” on page 616.

Adding Materials and Images

New materials, images, and plant images can be created in the User Catalog. Right-click on the User Catalog or a folder within it, select **New>** from the contextual menu, then select the type of item you wish to create from the submenu.

Home Designer Pro can use materials and images in a variety of file formats and provides several means of adding new material and image files to the library. For more information, see “Creating Materials” on page 637 and “To create an image in the Library Browser” on page 807.

Adding New Backdrops

Backdrops are images that display behind the model in 3D views. See “3D Backdrops” on page 679.

New backdrops can be created using a variety of graphic file formats. Backdrops are automatically adjusted to fit the window size, so they look best when they are created with the same height to width proportions as the window you are working in.



You can create digital photos of a building site for use as a backdrop.

To add a backdrop to the library

1. Select **File> Import> Backdrop**  to open the **Import Backdrop File** dialog, which is similar to the **Import Picture File** dialog. See “Importing Pictures” on page 812.
2. Browse to an image file on your computer, select it, and click **Open**. This backdrop can now be found in the My Backdrops library.

You can also create a new backdrop by copying and pasting an image into Home Designer Pro. See “Copying and Pasting Objects” on page 114.

Adding 3D Symbols

An imported symbol can be added to the library in either of two ways.

To import 3D symbols into the library

1. Select **File> Import> 3D Symbol** .
2. In the **Import 3D Symbol** dialog, make sure **Add Symbol to Library** is checked. See “Import 3D Symbol Dialog” on page 838.
3. Browse to the 3D file(s) that you want to import and either single or group-select the files so that their names displays in the **File Name** box.
4. Click the **Open** button.
 - A progress bar will display telling you the progress of each symbol, and once it has completed importing a file, that symbol will be located in the **Import** category of the Library Browser.

- Click and drag the imported content to the appropriate folder that you have created for it in your **User Catalog**.



If **Add Symbol to Library** is not checked when a symbol is imported into the program, you can still add it to the library at a later time by selecting it and clicking the **Add to**

Library  edit button. See “Add to Library” on page 613.

Adding a Customized Object

You can customize an existing library object and save your changes for future use by first copying the item into an unlocked library.

To customize a library object

- Right-click on a library item and select **Copy**  from the contextual menu.
- Browse to an unlocked library or library folder and right-click on it.
- Select **Paste** from the contextual menu to make a copy of the library item in this new location.
- Right-click on the copied item and select **Open**  from the menu.
- The item’s specification dialog opens, and you can make any changes that you wish to the item.
- Make any needed changes to the item, then click OK. Your changes will be saved with this item for use in any plan.

Organizing the Library

Library folders and objects can be copied, pasted, moved, and deleted: allowing you to organize your User Catalog to best suit your work style and needs.

Adding New Folders

New folders can be added to the User Catalog or to any folder located within it. To add a new folder, right-click on User Catalog or one of its sub-folders and select **New> Folder** from the contextual menu.

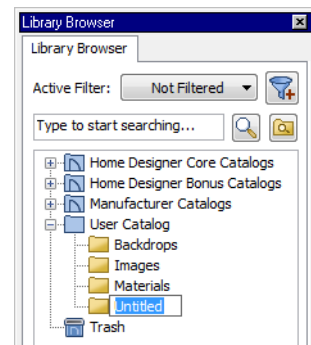

The new folder is created inside the library item you right-clicked on and is initially named “Untitled”. Type a short, descriptive name and press Enter.

Selecting Library Items

To select a library object, folder, or category, simply click on it. You can also multiple-select library items:

- To select a group of items, click on the first one, hold down the Shift key, then click on another file. The two files plus all files in between are selected.
- To select multiple items individually, click on one, hold down the Ctrl key, then click on additional files. Only the files you click on are selected.

When an item is selected, preview images display in the Selection and Preview Panes and basic information about it also displays in the program's Status Bar. See "The Status Bar" on page 31.

A selected library item can be modified in a number of ways to help meet your organizational needs. When multiple items are selected, these options may be limited depending on the specific selection set.

Renaming Library Items

Only folders and objects in the User Catalog can be renamed. There are several ways to do this from the tree list:

- Right-click on the item, select **Rename** from the contextual menu, and type a new name.
- Click once on the item, press F2 on your keyboard and type a new name.
- Click once on the item, pause for a moment, then click a second time and type a new name.

Library names are case-sensitive and can contain up to 63 characters. While you can have more than one library item that uses the

same name, it is best to use short, descriptive and unique names.

Moving Library Items

Folders and objects in the User Catalog can be moved to new locations within the User Catalog. Folders and library objects are always organized alphabetically within each hierarchy.

To move one or more items to a different location, select it in the tree list, then click and drag it to the new location in the list. Directories and folders able to accept new content highlight as your mouse pointer moves over them. Release the mouse button to relocate the selected library item in the highlighted location.

Copying Library Items

All library folders and library objects can be copied and pasted to new locations in the User Catalog.

There are two ways to copy one or more library items to the Windows Clipboard:

- Right-click on it and select **Copy** from the contextual menu.
- Click on the library item and press Ctrl + C on your keyboard.

To **Paste** the item, click on a library catalog or folder in the Library Browser tree view and either:

- Right-click on the new location and select **Paste** from the contextual menu.
- Press Ctrl + V on your keyboard.

When a library item is copied and pasted, the new item that results is independent of the original item. If you make changes to it, the

original item is unaffected. Similarly, changes to the original item do not affect the copy.

Library Shortcuts

In addition to copying and pasting to create new, independent library items, you can copy and paste to create Library Shortcuts. Library Shortcuts are not independent items - they are linked to the original item and are affected if changes are made to the original.

Library Shortcuts are advantageous because you can place a given library item in multiple locations to suit your organizational style without increasing the size of the library database and without having to maintain multiple copies of the same item.

To create a Library Shortcut, copy a library item to the Windows Clipboard. Then, right-click on the location where you would like to create a copy and select **Paste Shortcut** from the contextual menu. Library Shortcuts use the same name as their source item but use the Library Shortcut  icon.

To locate a Library Shortcut's source item, right-click on it in the tree list and select **Locate Shortcut Source**

If you move or delete an item from the library, any shortcuts to it will not be updated or removed. If you try to use a "hanging" shortcut, a message about its status will display in the library preview panes.

Deleting Library Items

The five installed library categories: Home Designer Core Catalogs, Home Designer Bonus Catalogs, Manufacturer Catalogs, User Catalog, and Trash cannot be deleted.

Catalog level folders in all categories can be deleted; however, individual subfolders and objects can only be deleted out of the User Catalog.

Items in the library that are eligible for deletion can be deleted in either of two ways:

- Right-click on it and choose **Delete** from the contextual menu.
- Select it and press the **Delete** key on your keyboard.

When items from the User Catalog are deleted, they are moved to the Library

Browser Trash . Items in the Trash can be retrieved by clicking and dragging them into any location in the User Catalog.

To empty the Trash , right-click on it and select **Empty Trash** from the contextual menu.

Depending on how much content is in the Trash, emptying it can be time consuming. You can click the **Cancel** button to end the process if you wish.



The Empty Trash command is both immediate and permanent. It cannot be undone, so use care when using it. You should back up all your library files regularly. See "Backing up Library Content" on page 610.

Filtering the Display of Library Content



Depending on how much library content you have imported or customized, the tree list in the Directory Pane can be very large. You can control what content displays in the list using **Library Filters**.

Library Filters do not remove content from the library database. They do, however, affect the library Search: unless you check **Include Filtered** in the advanced Search options, library content that is not displaying is not included in your searches.

You can also set up filters for your library Search results, but these two types of filters are unrelated. See “To search using custom filters” on page 609.

Library filters can be created, edited, and deleted in the **Manage Library Filters** dialog.

Click the **Manage Library Filters**  button at the top of the Library Browser to open this dialog or select **Library > Manage**

Library Filters  from the menu.



You can also add the Manage Library Filters button to your toolbars and assign a hotkey to it. See “Toolbars & Hotkeys” on page 91.

Any library filters that you create will be listed in the **Active Filters** list at the top of the Library Browser. Select a filter from the list to display content in the library tree list according to its settings. See “The Library Browser” on page 604.

Manage Library Filters Dialog

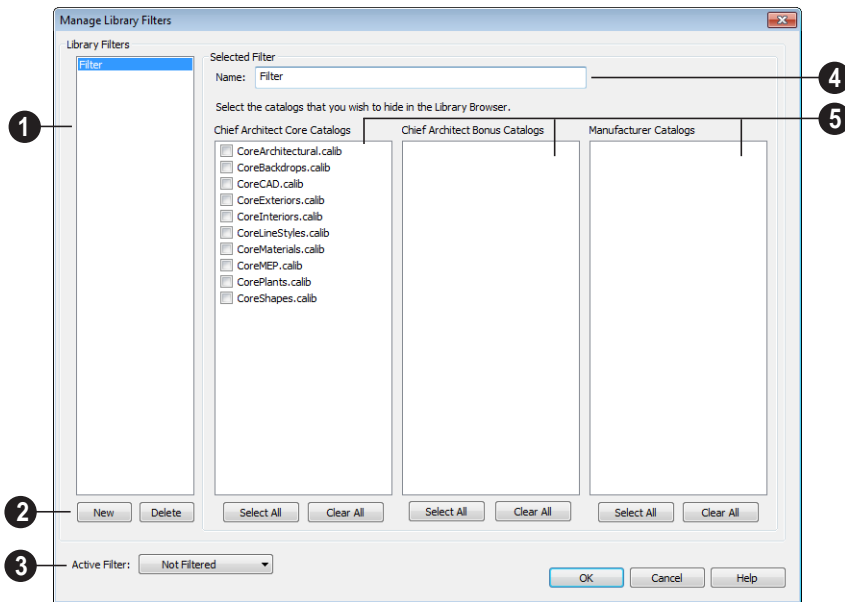

1 A list of available library filters displays here. Click on a filter in the list to select it. The Selected Filter is highlighted and can be edited using the options to the right.

2 Click the **New** button to create a new filter or click the **Delete** button to remove the Selected Filter from the list.

3 Select the **Active Filter** from the drop-down list. This is the filter in use in the Library Browser when the **Manage Library Filters** dialog is closed.

4 Specify the **Name** of the Selected Filter.

5 A list of all **Home Designer Core**, **Home Designer Bonus** and **Manufacturer Catalogs** installed in your library display here.

- Check the box beside a library catalog's name to prevent it from displaying in the Library Browser Directory Pane tree list.
- Click the **Select All** button below either list to prevent all catalogs in that list from displaying in the Directory Pane tree list.
- Click the **Clear All** button below either list to include all catalogs in that list in the Directory Pane tree list.

Exporting Library Catalogs

Exporting library files allows you to:

- Back up your custom library content.
- Transfer library content between computers.
- Share custom library content with colleagues.

Exporting is often preferable to simply copying library files because it allows you to include images and textures in the exported library.

To export content from the library

1. Locate an object, folder, or catalog that you want to export, right click on it, and select **Library > Export Library**.

2. In the **Export Library Data** dialog.
 - Choose the appropriate **Save in:** location for your exported library file.
 - Type a short, descriptive name for your library file in the **File Name** field.
 - Click the **Save as type:** drop down list and select whether or not you want the library to include Textures/Images.



If any of the items being exported are images or use textures, be sure to select the .calibz file type.

- Click **Save**.
3. Your exported library file can now be copied to a network location or storage device in Windows Explorer.

Placing Library Objects

Library objects are subject to placement restrictions based upon typical real-life placement. Most library objects require sufficient free space at the location where they are placed, for example, and some library objects have additional requirements.

Library windows and doors, for example, must be placed in a wall just like standard windows and doors, and some fixtures are designed to be placed in cabinets.

Library symbols have placement restrictions that are determined when the symbol is created but can be changed later. See “Native Objects vs Symbols” on page 626 and “Symbol Specification Dialog” on page 43.

If a warning message displays when placing a library object, it will indicate where the object can be placed.

There are three main categories of items available in the Library Browser:

- Stand-alone objects that can be placed directly into a plan. Examples include cabinet modules, furnishings and images.
- 3D objects designed to be inserted into another 3D object. Examples include cabinet fixtures, windows and doors. Some items, such as cabinet doors and fixtures and fence panels, can be inserted into another object or placed as stand-alone objects.

- Materials and molding profiles, which cannot stand alone and must be assigned or applied to another object.

Stand-Alone Objects

Most library categories contain objects that can be selected in the Library Browser and placed directly in a 2D or 3D view.

- Most stand-alone objects are designed to rest on the floor or terrain.
- Some objects will rest on top of a cabinet, shelf, furniture or roof plane object if one is located at the point where they are first placed.
- A few objects, notably some light fixtures, will mount on the bottom of a wall cabinet or on the ceiling.
- In addition, some objects will attach to a wall if one is nearby.

To place a stand alone library object

1. Click on an object in the tree view or Selection Pane of the Library Browser to select it for placement. See “The Library Browser” on page 604.
2. Move your cursor into the view area and notice that it displays an icon indicating the type of object selected instead of an arrow icon.
3. Click to place the selected object at that location.
4. Continue clicking to place as many instances of the selected object as needed. When you are finished, click the **Select Objects**  button.

Once a stand-alone object has been placed, it can be edited in a variety of ways. See “Editing Library Objects” on page 625.

Inserted Objects

Some objects cannot stand alone and must be placed into other objects in a plan. For example, doors and windows must be inserted into a wall, while some appliances and plumbing fixtures must be placed inside a base cabinet. See “Doors” on page 253, “Windows” on page 279 and “Cabinets” on page 507.

An inserted object can only display in a 2D or 3D view if the object that contains it is set to display. This is the case even if the inserted object’s layer is turned on. See “Displaying Library Objects” on page 624.

To insert a library object

1. Click on an object in the tree view or Selection Pane of the Library Browser to select it for placement. See “The Library Browser” on page 604.
2. Move your cursor into the drawing area.
3. Click on the object into which you wish to insert the selected library item. The library item is inserted into the object.
4. Continue clicking to place as many instances of the selected item as needed. When you are finished, click the **Select Objects**  button.

Assigned Items

Some library items, such as moldings and materials, are not objects in themselves but can be applied to objects in a variety of ways.

- Using the specification dialog of the containing object. See “Select Library Object Dialog” on page 622.
- By selecting the item in the library and then clicking on the containing object in floor plan view.
- Materials can be assigned to objects directly from the library in 3D views by selecting the material and then clicking on an object’s surface. See “The Material Painter” on page 632.

Select Library Object Dialog

The **Select Library Object** dialog is a modal version of the Library Browser that is accessible from object specification dialogs that display the **Library...** button. Click this button to select and apply items from the library to the object currently opened for specification. See “Specification Dialogs” on page 31.

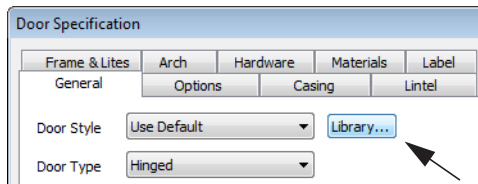

The **Select Library Object** dialog only displays categories that are related to the opened object. For example, this is how the dialog looks when accessed from the General tab of the **Door Specification** dialog:

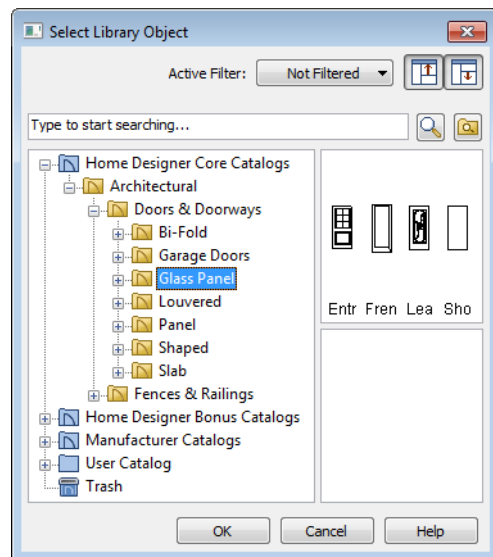

To make your selection, highlight the desired object and click **OK**, or simply double-click on the object in the Selection Pane to close the **Select Library Object** dialog.

The **Select Library Object** dialog includes the search and search filtering options, can be resized \leftrightarrow , and can display the resizable Preview and Selection Panes.

If the **Select Library Object** dialog is opened by clicking the **Library Material** button on the Materials tab of any specification dialog

or using the **Material Painter** , two additional options are available:

- Click the **Add New Material**  button to open the **Define Material** dialog and create a new material.

- Check **Use default material** to apply the default material for the selected object, if one exists. See “Material Defaults” on page 650.

See “Materials Tab” on page 635 or “The Material Painter” on page 632.

Place Library Object Button



The **Place Library Object** button can be added to your toolbar and used for quick access and placement of frequently used library items.

If the **Place Library Object**  button has not yet been assigned a library object, click it once to open the **Library Object Button Specification** dialog.

Double-click a **Place Library Object**  button that has been assigned a library object to open the **Library Object Button Specification** dialog.

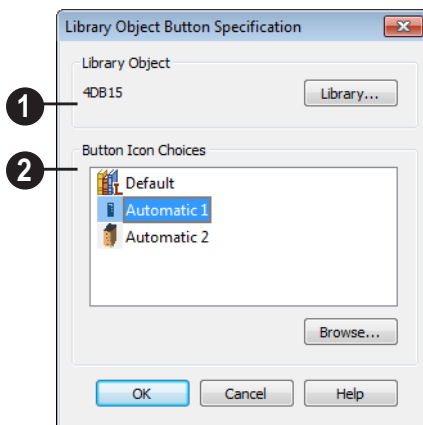

- 1 Click the **Library** button to open the **Select Library Object** dialog and assign a library object to the button. If a library object has already been assigned, click this button to assign a new library object. See “Select Library Object Dialog” on page 622.

- 2 When a library object has been selected, assign a button icon. Choose from two automatically generated button icons or click **Browse** to browse your computer for a different icon.

Up to 100 **Place Library Object**  buttons can be added to the same toolbar, each assigned a different object.

The library object assigned to the **Place Library Object**  button is actually saved with that particular button. If you move or delete the library item from the library, the button will continue to function.

Replace From Library

The **Replace From Library** edit button is available for most selected objects. Click this button to open the **Replace From Library** dialog and replace the selected object, and others like it if you choose, with an object of the same type from the library.

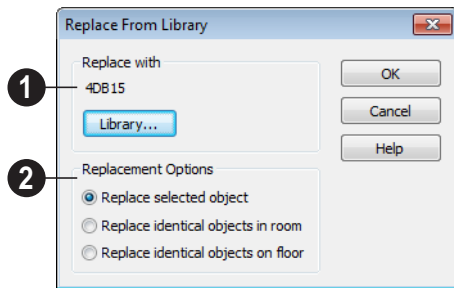

1 Click the **Library** button to open the **Select Library Object** dialog and select an object to use as a replacement. The name of the object that is currently selected as a replacement displays above.

2 Select one of the **Replacement Options**.

Select **Replace Selected Object** to replace only the currently selected object.

Select **Replace Identical Objects in Room** to replace all objects that are in the same room as, and are identical to, the currently selected object.

Select **Replace Identical Objects on Floor** to replace all objects that are on the same floor as, and are identical to, the currently selected object.

A few things to remember about **Replace From Library**:

- Works in floor plan and 3D views.
- The replacement option **Replace Identical Objects in Room** is not available for doors and windows.

Replace From Library is available for any object that can be stored in the Library Browser and can be selected, including: architectural objects, architectural blocks, electrical objects and image objects.

Objects that cannot be replaced using this feature include materials, backdrops, and items assigned to other objects, such as materials.

Displaying Library Objects

The display options available for library objects depend on the type of object in question, as well as the view.

If the display of an object is turned off in a 2D or 3D view, any objects inserted into it will not display in that view, either - even if

the inserted object's layer is turned on. See "Inserted Objects" on page 621.

In Floor Plan View

All library objects except materials, doors and drawers applied to cabinets, and backdrops can display in floor plan view.

Library objects are represented in floor plan view by 2D symbols that resemble the size and shape of the object when viewed from above. To learn how to specify the symbol that represents an object, see “Image Specification Dialog” on page 809.

As with other architectural objects, the display of library objects is controlled by layer in the **Layer Display Options** dialog. Each library category has its own layer. See “Layer Display Options Dialog” on page 104.

Symbols belong to one of three drawing groups that influence which objects display in front of others in floor plan view. You can click the **Move to Front of Group**  edit button to display a selected symbol in front of over symbols or architectural blocks. See “Drawing Groups” on page 150.

Object Labels

Fixtures, Furnishings, Geometric Shapes, Hardware, Millwork, Architectural Blocks and Plants can display labels in floor plan view when the appropriate layer is set to display in the **Layer Display Options** dialog. For example, fixture labels are placed on the “Fixtures, Labels” layer. See “Object Labels” on page 884.

Library object labels use the Text Style assigned to their layer. See “Text Styles” on page 765.

You can also specify a custom label for an individual object in its specification dialog. See “Label Tab” on page 885.

In 3D Views

All library objects can display in 3D views.

By default, images rotate to face the camera in 3D views. For information about turning off image rotation, see “Image Specification Dialog” on page 809.

Doors, windows and cabinets from the library may also display opening indicators in Vector Views when the “Opening Indicators” layer is turned on. See “Displaying Objects” on page 102.

In the Materials List

Most library objects are counted in the Materials List, as are any comments added to the **Components** dialog for a library object. See “Components Dialog” on page 901.

Note: Although the size and materials of many library objects can be edited, these changes are not reflected in the Materials List. See “Materials Lists” on page 887.

Editing Library Objects

Like native Home Designer Pro objects, library objects can be customized to suit your design needs. There are three approaches to editing library objects:

- Select an object in the User Catalog, edit it using any of the options in its contextual menu, and your changes will be reflected when you next place this library object in a drawing.



- Place an object in a drawing and then edit it using the various edit tools available for it. This will not affect the original object still saved in the library.
- Place an object in a drawing, edit it using the available edit tools, and then add it back to the library for future use. This will not replace the original object still saved in the library. See “Add to Library” on page 613.

Library objects placed in a drawing can be selected individually or as a group, like other objects in Home Designer Pro. See “Selecting Objects” on page 124.

Once selected, library objects can be edited in a variety of ways using dimensions, the edit handles, the edit toolbar buttons and the specification dialog. See “Symbol Object Specification Dialogs” on page 627.

Native Objects vs Symbols

In Home Designer Pro, objects created using the program’s standard tools, such as the

Door Tools  and **Cabinet Tools** , are referred to as native objects.

On the other hand, objects placed from the library, such as fixtures and furnishings, are symbols. Symbols are typically more limited than native objects in how they can be edited.

In addition to the symbols available in the library, you can import additional symbols into the program from 3D **.obj**, **.3ds** or **.skp** files. See “Importing 3D Symbols” on page 838.

Using Edit Handles

Most library symbols are box-based objects and can be edited as such once placed in a drawing. See “Editing Box-Based Objects” on page 141. Depending on the type of view and the surface selected, the edit handles a symbol displays will vary.

To resize Fixtures and Furniture, you must check **Fixture/Furniture Resize Enabled** in the **Plan Defaults** dialog. When this option is checked, these library objects have edit handles when selected and can be resized like other objects. See “General Plan Defaults Dialog” on page 58.

When a furnishing or fixture symbol is selected in floor plan view or on the top surface in a 3D view, up to ten edit handles display. They are the Move handle at the center, the Rotate handle just outside the front indicator (a V) and a Resize handle on each edge and at each corner.

When a symbol is selected on a side in a cross section/elevation or 3D view, it displays five edit handles: the Move handle and a Resize handle on each edge.

Symbols cannot be concentrically resized, even when the **Concentric**  edit behavior is enabled. See “Edit Behaviors” on page 120.

The labels of library cabinets, electrical, furnishings and fixtures, when displayed, have a separate Move edit handle that displays when the object is selected.

Fixtures and furniture placed in a plan are subject to bumping/pushing behavior when moved. See “Bumping/Pushing” on page 152.

Deleting Built-in Fixtures and Appliances

A fixture installed into the front of a cabinet becomes a cabinet face item, like a door or drawer. It can be resized or deleted like other face items in the **Cabinet Specification** dialog. See “Front Tab” on page 526.

Components



Many architectural objects have a **Components** dialog that lets you control how that object displays in the Materials List. In the Library Browser Directory Pane, right-click on a symbol and select **Components** to open the **Components** dialog. See “Components Dialog” on page 901.

Changes made to the Components of an object saved in the library do not affect instances of that object already placed in a

plan: they are only applied to instances of the object placed in the future.

Once placed in a plan, many objects have a **Components**  edit tool that allows you to make changes to that object’s Components without affecting the symbol in the library.

Terrain objects, CAD blocks, moldings, images, backdrops, and materials do not display in the Materials List.

In the Specification Dialog

The specification dialog for any image, material, or plant image in the library can be edited from the Library Browser Directory Pane. See “Specification Dialogs” on page 31.

Specification dialogs are not available for native objects saved in the library.

Symbol Object Specification Dialogs



The **Fixture, Furniture, Geometric Shape, Hardware, and Millwork Specification** dialogs all feature the same options. The actual name of the dialog is determined by the type of object that is currently selected.

For example, selecting a library object placed from the Interiors Core Catalog and clicking the **Open Object**  edit button opens the **Furniture Specification** dialog.

General Tab

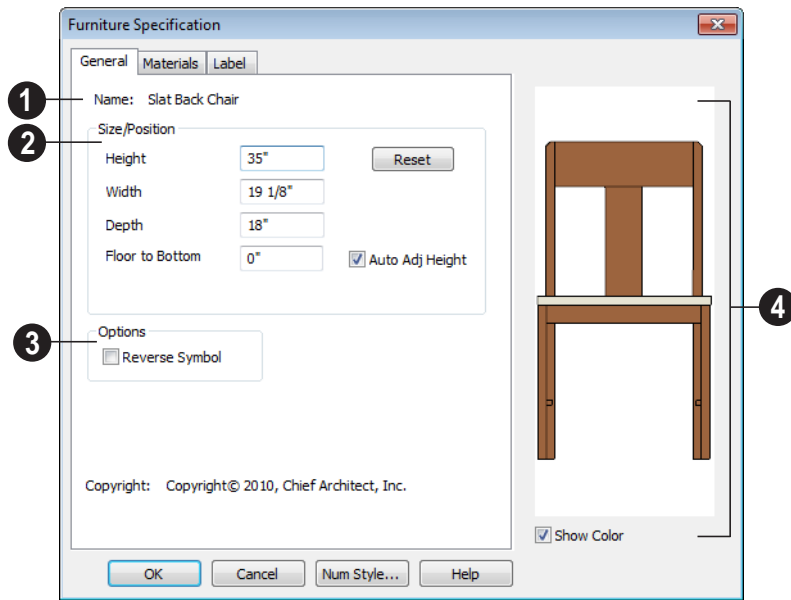

- 1 The **Name** of the selected object displays here.
 - 2 **Specification** - Define the size and height above the floor of the object.
 - Specify the **Height**, **Width**, and **Depth** of the object.
 - **Floor to Bottom** - Enter the distance from the floor to the bottom of the object. A value of zero makes the object rest on the floor.
 - If the selected symbol is ceiling mounted, **Height Above Ceiling** will be available instead of Floor to Bottom. Specify the selected object's height above the ceiling. Enter a negative value to offset the symbol below the ceiling, or uncheck **Follow Ceiling** if you prefer to specify the object's Floor to Bottom height instead.
- Click **Reset** to reset the symbol's original, unmodified size. The Floor to Bottom value is not affected by this button.
 - When the selected object is outside a room and **Auto Adjust Height** is checked, its Floor to Bottom height is measured relative to the terrain height. When this is unchecked, the Floor to Bottom height is measured from the default floor height of Floor 1. See "Terrain Height vs Floor Height" on page 539 of the Reference Manual.
- 3 Check **Reverse Symbol** to reverse the object's appearance, so that features on its left are positioned on its right, and vice versa. This turns a right-hand refrigerator, for example, into a left-hand refrigerator. This option has no effect on objects that are symmetrical.

- 4 A preview of the library object displays here and updates with changes.
- Check **Show Color** to display the preview of the object in color.

Materials Tab

For information about the settings on this tab, see “Materials Tab” on page 635.

Label Tab

A variety of library objects can display labels in floor plan view. Labels use the Text Style

assigned to the layer they are on. See “Object Labels” on page 625.

For information about the settings on this tab, see “Label Tab” on page 885.

Manufacturer Tab

If the selected symbol or material is from a Manufacturers catalog, the Manufacturer’s tab lists contact information about the manufacturer. See “Manufacturer Catalogs” on page 610.

Materials

The objects used in Home Designer Pro have a variety of 3D properties. These objects - walls, windows, doors, cabinets, roof planes, lot perimeters, etc. - can have materials assigned to them so that they look realistic in 3D views. These materials can also be used to generate materials lists that can help with cost estimations.

Designing with objects that look correct in 3D and calculate properly in the Materials List requires that you use realistic material definitions and apply them appropriately to objects in your plan.

Home Designer Pro comes with many materials that are ready for use. From siding, roofing, flooring, masonry, tile, and paneling, to grass, water, and wood materials, Home Designer Pro has materials for every application, inside and out. If you cannot find a material that suits your needs, you can customize the materials provided or create your own.

Learning how to create, manage, apply, and edit materials saves time and adds that professional touch to your designs.



Redefining only the visual properties of a material may create unexpected results. For example, changing the image of a brick material to represent siding does not cause the material to be considered as siding during material calculations.

Chapter Contents

- About Materials
- The Material Painter
- Materials Tab
- Viewing Materials
- Editing Materials
- Creating Materials
- Mapping Patterns and Textures
- Material Types
- Managing Plan Materials
- Define Material Dialog
- Material Defaults
- Color Chooser Dialog

About Materials

The materials that are assigned to objects in Home Designer Pro perform two important roles:

- They determine what the surfaces of objects look like in 3D views.
- They influence how objects are calculated in the Materials List. See “Materials Lists” on page 887.

Materials are stored in the Materials library in the Library Browser and can be applied to objects in either of two ways:

- Using the **Material Painter** .
- In an object’s specification dialog. See “Materials Tab” on page 635.

Patterns and Textures

In Home Designer Pro, materials have two attributes that determine what they look like in 3D views: Textures and Patterns.

- Textures are created using special image files that tile seamlessly when applied to surfaces and are visible in most Render-

ing Techniques. See “In Rendered Views” on page 678.

- Patterns are composed of CAD lines and are seen in Technical Illustration and Vector Views. See “Rendering Techniques” on page 710.

Unlike textures, patterns are associated with a Type that determines if and how materials are calculated in the Materials List.

Material Types

Every material is classified by Type, which defines how the material is calculated in the Materials List. Not every Type is calculated in the Materials List; however, most determine whether a material is counted by piece, area, volume and so on. See “Material Types” on page 640.

Some Types are associated with patterns. Only Home Designer Pro Pattern Types are figured in the Materials List. If a **.pat** file is selected, the pattern type is listed as Custom. See “Pattern Tab” on page 647.

The Material Painter



Select **3D > Material Painter** to access the **Material Painter Tools**, which are used to apply materials to object surfaces in 3D views.

The **Material Painter**  tool can also be activated by selecting a material in the library while a 3D view is active.









If you use the Material Painter to change a Deck room’s planking or framing will affect its floor structure definition. See “Floor and Ceiling Platform Definitions” on page 322.

Material Painter Modes

There are five Material Painter Modes. Each mode specifies how broadly or narrowly the

selected material will be applied to surfaces in your plan.

- The **Material Painter Component Mode**  is the default mode. This applies the selected material to an object component. Using this tool is the same as opening an object for specification and changing the material for one of its components on the Materials tab. See “Materials Tab” on page 635.
- The **Material Painter Object Mode**  applies a material to all components of an object that share the same material assignment.
- The **Material Painter Room Mode**  applies a material to all the objects in the room that currently have the same material. For example, if you apply a material to a dining room chair, this mode applies the material to all other objects in the room with the same original material, such as other chairs and the dining table.
- The **Material Painter Floor Mode**  applies the selected material to all surfaces on the floor that currently have the same material. For example, if you apply a material to the kitchen countertops using this mode, the bathroom countertops on the same floor also have the material applied.
- The **Material Painter Plan Mode**  applies the selected material to all surfaces in the entire plan that currently have the same material. For example, if you have the same carpet on all floors in a plan, applying a selected material while this mode is active will change all carpet on all floors.

When the **Material Painter**  tool is active, the Material Painter Mode toolbar buttons display in the edit toolbar, allowing you to quickly change modes.



You can also specify the active mode by selecting **3D> Material Painter** . A check displays next to the active mode in the submenu.

Blend Colors With Materials











In addition to the Material Painter Modes, the **Blend Colors With Materials** option allows you to apply a solid color to a surface displaying a pattern or texture and blend the two.

Blend Colors With Materials  works in all five Material Painter Modes. See “Blending Materials” on page 638.

To use the Material Painter tool



1. Create a 3D view in which the patterned/textured material is visible.
2. Select **3D> Material Painter> Material Painter** .
3. Select a solid color material from the **Select Library Object** dialog. See “Select Library Object Dialog” on page 622.
 - Check **Use Default Material** at the bottom left of the dialog to apply the default material to any object that has a defaults dialog. See “Material Defaults” on page 651.

4. Select a Material Painter Mode from the edit toolbar, which displays at the bottom of the program window when the Material Painter is enabled.
5. Click the **Blend Colors With Textures**  edit button to turn this feature on or off depending on your needs.
6. Note that the name of the material being painted displays on the left side of the Status Bar at the bottom of the program window. See “The Status Bar” on page 31.
 - Move your pointer over a surface in the 3D view. The Status Bar now states both the material being painted and the current material on the target surface.
7. Click on the surface to apply the selected material to that surface. The material is applied to surfaces in the model based on the active Material Painter Mode.
 - When both the **Material Painter**  and **Blend Colors With Textures** are active, the cursor displays a paint roller icon .
 - When the **Material Painter**  is active and **Blend Colors With Textures**  is not, the cursor displays a spray can icon .
8. If either the **Component**  or **Object Mode**  is active, you can continue to click on surfaces to apply the selected material. When you are finished, select a different tool.

Material Painter & Walls

As a general rule, the **Material Painter**  cannot be used to apply a material to an individual wall. Rather, it applies the material to an entire room, to all the rooms on the floor, or to all the rooms in the entire plan, depending on which Material Painter Mode is active.

There are a couple of exceptions to this rule that apply when the wall surface being painted faces an exterior room such a porch and/or the Exterior Room. See “Room Types” on page 234.

- If the **Material Painter Room Mode**  is active, the selected material is applied to the entire exterior room. If any walls defining this room also define other exterior rooms, their entire lengths are also affected.
- If the **Material Painter Component Mode**  is active, the entire length of the individual wall is painted. Other walls defining the exterior room(s) are unaffected.

Material Eyedropper

 The **Material Eyedropper** tool allows you to load the material assigned to an existing object and apply that material to other objects.

In a 3D view, select **3D> Material Painter> Material Eyedropper**  and then move your mouse pointer over a surface in the view. The name of the material on that surface is stated on the left side of the Status Bar. Click on the surface to load its material assignment. The pointer then changes to

indicate that the material is ready to be applied to another object using the **Material Painter**  tool. Depending on the currently

active **Material Painter Mode**, you can continue to apply the material to the surfaces of other objects.

Materials Tab

The specification dialogs for most objects include a Materials tab. Select an object or a group of similar objects and click the **Open Object**  edit button to open the specification dialog for that selection.

On the Materials tab, you can specify material assignments for the components that make up that object. When a new material is assigned, the appearance of the preview image on the right side of the dialog updates.

The tree list on the left side of the tab lists the components of the selected object that can be assigned materials. Some objects may only have a single component while more complex objects may have many.

Some components contain additional sub-components, which display separately in the components tree list.

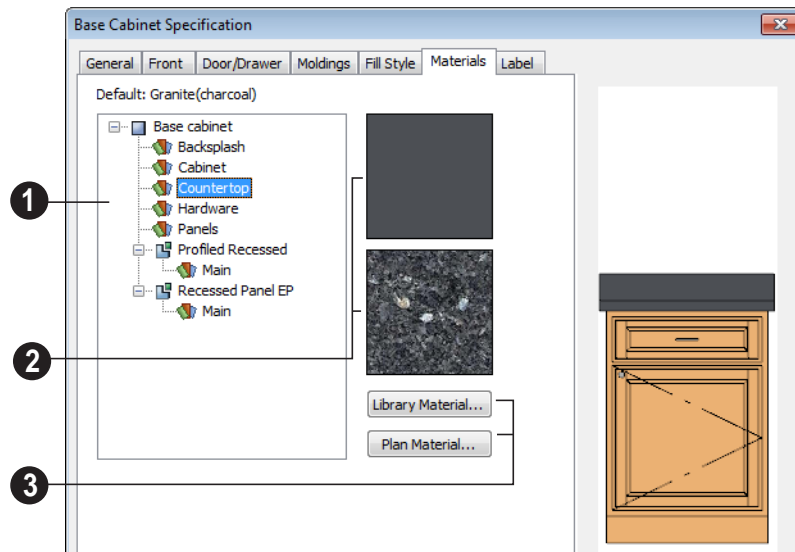

- 1 Select a component in the tree list to assign a new material to it.
- 2 The two boxes to the right of the tree list display a preview of the color,

pattern and texture of the material assigned to the selected component. If “No Texture” displays in the preview window, either the

material has no texture assigned or the texture file could not be found on the system.

3 Click **Library Material** to open the **Select Library Object** dialog. Select a material and click **OK** to assign that material to the selected component. See “Select Library Object Dialog” on page 622.

Click the **Plan Material** button to open the **Plan Materials** dialog and select a material from those already used in your plan. See “Managing Plan Materials” on page 642.

Select **OK** to close the dialog and return to the active view.

Viewing Materials

Textures display in most Rendering Techniques, while patterns display in Technical Illustration and Vector Views. See “Displaying 3D Views” on page 677.

In Technical Illustration and Vector Views, you can turn the display of material patterns on and off by selecting **3D> Toggle Patterns**



. See “Rendering Techniques” on page 710.

If you receive an error message regarding a missing file when creating a 3D view, your

plan might contain two textures of the same name or textures that did not originally come with the program and are not currently saved in the library.

To resolve this, find the original texture file named in the error message and copy it (while recreating its path) into the “Old Textures” folder. The next time Home Designer Pro is opened, it will find the missing file and correctly show the texture.

Editing Materials

Much like objects, materials in Home Designer Pro can be edited so that they better suits your design needs. There are two approaches to material editing:

- Select a material in an unlocked library in the Library Browser, edit it, and your changes will be used when you next use the material in any plan. Changes made in this manner do not affect materials already in use in a plan.
- Apply a material to an object in a plan and then edit that applied material using either the **Plan Materials** dialog or **Adjust**

Material Definition  tool. Changes made in this way will affect any instances of that material in the current plan only.

Editing the material applied to an object is not the same as applying a different material to that object. See “The Material Painter” on page 632.

Library Browser

Right-click on a material in an unlocked library and select **Open** from the contextual menu to open the **Define Material** dialog for

that material. See “Define Material Dialog” on page 644.

Plan Materials



Select **3D> Materials> Plan Materials** to open the **Plan Materials** dialog for the current plan. Select a material and click the **Edit**, **Copy**, or **New** button to open the **Define Materials** dialog.

Adjust Material Definition



The **Adjust Material Definition** tool is useful for changing plan materials directly from a 3D view.

Select **3D> Materials> Adjust Material**

Definition  and then click any surface in a 3D view to modify the material currently assigned to that surface in the **Define Material** dialog. See “Define Material Dialog” on page 644.

Changing a material definition with this tool affects all objects in the current plan that are using that material but does not affect any materials saved in the library or materials used in other plans. See “Adding Library Content” on page 613.

Creating Materials

Home Designer Pro provides a wide variety of materials - including numerous name brand material catalogs - that are ready to download and use. If you cannot find a suitable material, you can edit an existing material or create a new one. See “Editing Materials” on page 636.

In the Plan Materials Dialog

There are two ways to create a new material in the **Plan Materials** dialog. See “Plan Materials Dialog” on page 643.

- Click the **New** button to create a new material for use in the current plan file.
- Select a material and click the **Copy** button to make a new material based on the original, which can then be edited and used in the current plan.

In the Library Browser

Materials can be created in the Library Browser, making them available for use in any plan. See “Adding Library Content” on page 613.

In the directory pane of the Library Browser, right-click on an unlocked folder and select **New> Material** from the contextual menu. See “Using the Contextual Menus” on page 607.

In the **Define Material** dialog, you can create a new material in the selected unlocked folder. See “Define Material Dialog” on page 644.

Using Paste Image

You can create a new material by first copying an image that will serve as its texture to the Windows Clipboard, then navigating to a Home Designer Pro window

and selecting **Edit> Paste> Paste**  from the menu. See “Paste” on page 115.

Blending Materials



In 3D views, you can create a new material by blending a solid color such as a paint color with a textured and/or patterned material. Select **3D> Material Painter> Blend Colors With Materials** to toggle this feature on or off. See “Blend Colors With Materials” on page 633.

The result is a new material that is saved in the current plan. It can be found in the **Plan**

Materials dialog, edited as needed, and added to the library if desired. See “Plan Materials Dialog” on page 643.

Materials created using the **Blend Colors**

With Materials  tool are given the name of the patterned/textured material with the extension “--PAINTED:” followed by the name of the solid color material.

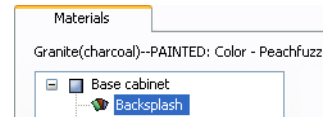

Mapping Patterns and Textures

Materials have two attributes that determine what they look like in 3D views: patterns and textures. See “About Materials” on page 632.

Both patterns and textures have points of origin, which determine where the pattern or texture begins on an X/Y axis. By default, this origin is 0,0; however, you can specify a different origin in the **Define Material** dialog.

- The origin of a texture can be set either globally or independently for each object. By default, texture mapping is per object. See “Texture Tab” on page 648.
- The origin of a pattern is always per object. See “Pattern Tab” on page 647.

If a texture is set to map globally, it may not look right on some surfaces in 3D views. If this is the case and you do not wish to map the texture independently on each object, you can create a copy of the material for each

surface that requires modification and specify its texture’s origin.

Determining the Origin

Before a new origin can be specified, the display of coordinates in the Status Bar should be enabled. See “The Status Bar” on page 31.

To determine origin coordinates on the horizontal plane, place your cursor over the origin location in floor plan view. When the pointer is in the position you want to establish as the material origin, take note of the coordinates that display in the Status Bar.

To determine origin coordinates on the vertical plane, place your cursor over the origin location in a cross section/elevation view.

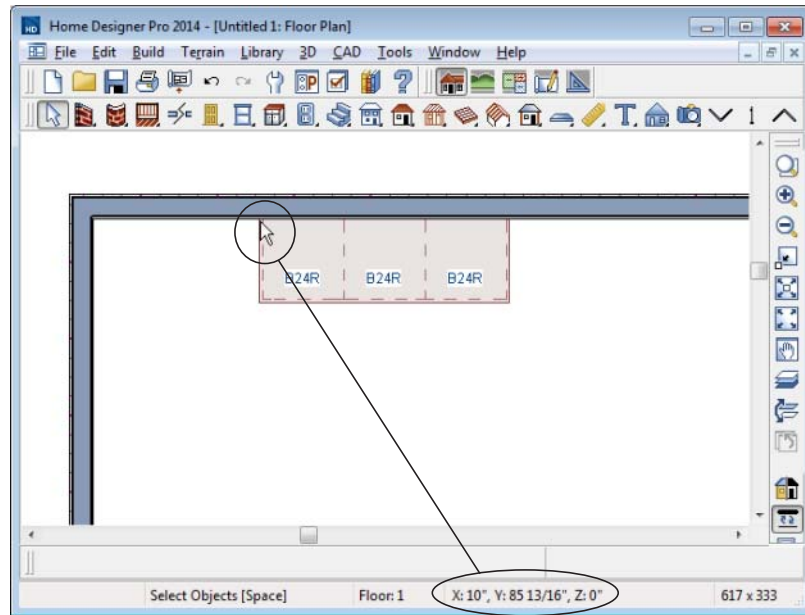

The pointer's current coordinates display in the Status Bar

Once you have taken note of the new origin coordinates, enter them on either the Pattern or Texture tab of the **Define Material** dialog. See “Define Material Dialog” on page 644.

A texture or pattern origin is a property of the material rather than of the object that the material is assigned to. When an object is moved, the pattern or texture maintains its absolute position and may not look right. It is a good idea to assign pattern or texture origins only after the position of the object has been finalized.



If you have multiple objects using the same material, they all share the same origin. Duplicate materials can be created if you want different origins specified for the same texture or pattern.

Stretch to Fit

Some special textures, often used for artwork, do not tile. Instead, these textures resize to stretch across any surfaces that they are applied to. Materials that behave this way are specified as **Stretch to Fit** in the **Define Material** dialog.

To display an artwork texture, first place a wall or desk frame in your plan. A selection of both are available in the library. See “Placing Library Objects” on page 620.

Next, simply apply a material specified as **Stretch to Fit** to the center portion of the frame. See “The Material Painter” on page 632.

For more information about creating and using custom materials, see “Materials Tutorial” on page 145 of the User’s Guide.

Material Types

Every material is classified by **Type** in the **Define Material** dialog. See “General Tab” on page 645. The Type defines how the material is calculated in the Materials List. Some but not all Types are associated with patterns that display in Vector Views. See “Vector View” on page 711.

Not every Type is calculated in the Materials List. Those that are are only calculated when assigned to structural components like wall, floor and ceiling, or roof layers; slabs; or generic objects like Primitives.

Following are the available Material Types and their characteristics:

Type	Pattern	Options	Materials List
Framing	None	n/a	Calculates stick framing quantities when assigned to the Main Layer of a wall type definition, or a layer in a floor or ceiling structure or finish definition. See “Framing” on page 435.
Brick	Typical staggered running bond brick course.	Height, Length, Depth and Mortar Width.	Calculates the number of units based on the total surface area. For a masonry wall with two layers of brick, create a wall type with two layers to get the right count. This Type can be specified for anything using this style of layout, such as plywood with staggered joints.
Strip	Parallel lines.	Height, Grouping, and Overlap Amount.	Calculates lineal footage based on the surface area and the height of the strip minus the Overlap amount. Grouping can be used to model a material that has a repeating pattern across its width.
Sheet	None	n/a	Calculates the number of sheets required to cover the surface area.

Type	Pattern	Options	Materials List
Gap	None	n/a	Gap materials create a space between materials. This is equivalent to defining no material at all and is not calculated in the Materials List.
Area	None	n/a	Calculates the total surface area.
Volume	None	n/a	Calculates cubic feet (meters).
Concrete	None	n/a	Calculates cubic yards (meters).
Tile	Grid	Height, Width, Thickness, and Joint Width.	Calculates the number of units required to cover the surface area.
Shingles	Rows of staggered rectangles.	Height, Width, Thickness, and Overlap Amount.	Calculates the number of shingles required to cover the surface area.
Flooring	None	n/a	Calculates the total surface area.
Shakes	Staggered rows of uneven rectangles.	Height, Width, Thickness, and Overlap Amount.	Calculates the number of shingles required to cover the surface area.
Herringbone	Herringbone.	Height, Length, Depth and Mortar Width. Height and Length are restricted to a 2:1 ratio.	Calculates the number of units required to cover the surface area.
Octagon	Octagons and small squares.	Height, Length, Depth and Mortar Width. Height and Length refer to the small square edges and are restricted to a 1:1 ratio.	Calculates the number of units required to cover the surface area. Units are composed of one octagon and four squares.
Hexagon	Hexagon	Height, Length, Depth and Mortar Width. Height and Length are restricted to a 1:1 ratio..	Calculates the number of units required to cover the surface area.
Parquet	Square parquet units	Size.	Calculates the required number of parquet units to cover the surface area.
Textured	Similar to a Sand fill style.	Spacing.	The Materials List does not calculate this material Type.

Type	Pattern	Options	Materials List
Earth	Alternating hatch pattern similar to Parquet.	Size.	The Materials List does not calculate this material Type.
Stars	Six sided stars.	Size.	The Materials List does not calculate this material Type.

Managing Plan Materials



The **Plan Materials** dialog can be used to manage the materials used in the current plan. Select **3D> Materials> Plan Materials** to open this dialog.

When a material is applied to an object in a plan, a copy of that material is made and saved with the plan. If you access the **Define Materials** dialog through a menu or specification dialog, your changes affect that

material wherever it is found throughout that plan. Other objects in that plan that use that material are also affected, but objects outside the current plan are not.



All materials that come with Home Designer Pro are stored in the Library Browser. You can also create your own materials and save them in the Library Browser. See "Creating Materials" on page 637.

Plan Materials Dialog

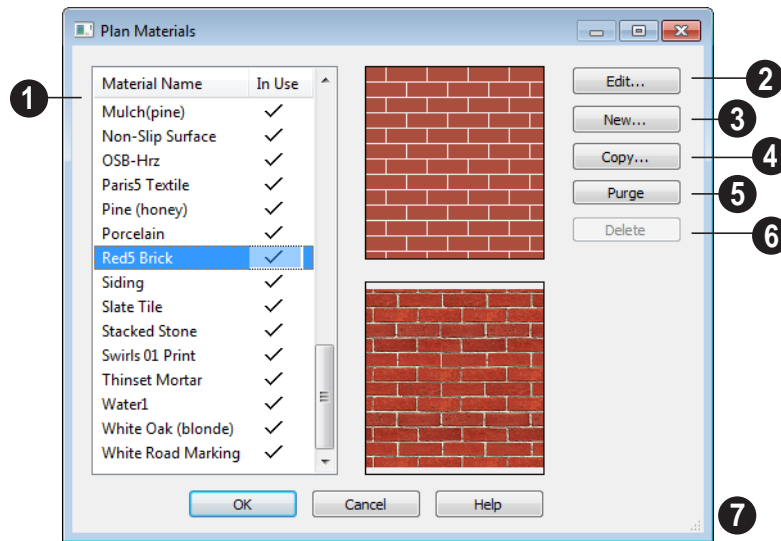

- 1** This is the list of materials in your plan. Click on the name of a material in the list to select it and display a preview of it to the right. If multiple materials are selected simultaneously by holding down the Shift or Ctrl keys, no previews will display.

If a checkmark displays in the **In Use** column, the material is used by an object in your plan or is defined as a default material for one or more objects in your plan.

If the **In Use** column is empty, the material was referenced at one time but is no longer assigned to any objects or used as a default.

- 2** Click **Edit** to open the **Define Material** dialog for the selected material. See “Define Material Dialog” on page 644.

- 3** Click **New** to open the **Define Material** dialog to create a new material.
- 4** Click **Copy** to create a copy of the selected material and opens the **Define Material** dialog where you can make changes to the copied material.
- 5** Click **Purge** to remove all unused materials from the plan.
- 6** Click **Delete** to remove the selected material from the plan. If the material is used in the model, you cannot delete it.
- 7** Click and drag the size grip to resize the dialog box.

Define Material Dialog

The **Define Material** dialog allows you to adjust how materials look in 3D views and can be accessed in a number of ways:

- Use the **Adjust Material Definition**  tool. See “Adjust Material Definition” on page 637.
- Select a material from the **Plan Materials** dialog and click **Edit**, **New**, or **Copy**. See “Managing Plan Materials” on page 642.
- Right-click on a material in an unlocked library in the Library Browser and select **Open** from the contextual menu. See “Using the Contextual Menus” on page 607.

- You can also right-click on an unlocked library and select **New> Material**.

If you select a manufacturer’s material, the options in the **Define Material** dialog may change. Some options are not available and the tabs may vary.

If you access the **Define Material** dialog through a menu or specification dialog, your edits affect that material wherever it is found in the current plan. Other objects in that plan that use that material are also affected, but objects outside the current plan are not.

General Tab

The options on the General tab will vary depending on the selected material Type.

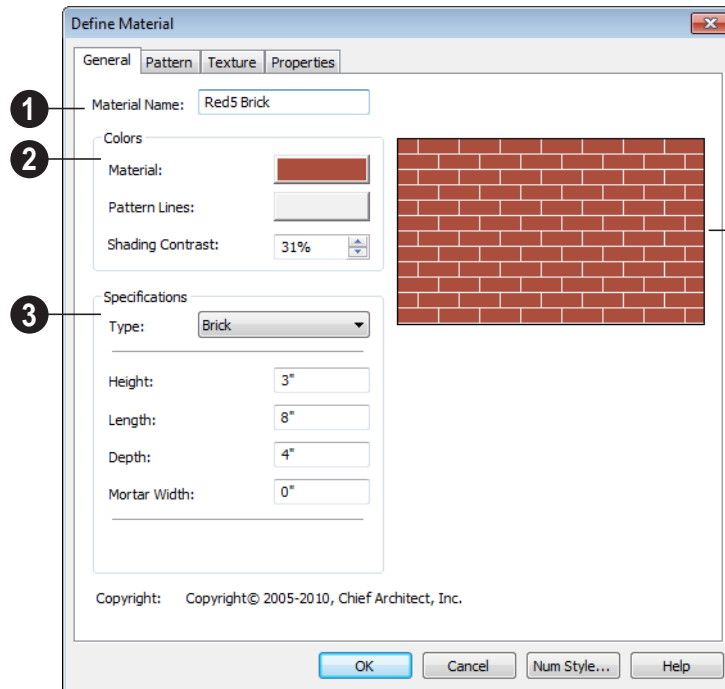

- 1 The **Material Name** displays here. You can type a different name if you wish. Renaming the material does not create a new material: it redefines the existing material. See “Creating Materials” on page 637.
- 2 Specify the **Colors** used to represent the material’s pattern in Vector Views. Click a color box to open the **Color Chooser** dialog and select a color. See “Color Chooser Dialog” on page 652.
- The **Material** color displays in Vector Views and in rendered views if **Toggle Textures**  is off or if no texture has

been selected. See “In Vector Views” on page 678.

This color also affects a material’s Transparency: choose white for a fully transparent material or black for one that is completely opaque. See “Properties Tab” on page 650.

- The color of the **Pattern Lines**, which display in Vector Views, displays here.
- Specify the **Shading Contrast**, which is the amount of contrast between surfaces at different angles to each other in 3D Vector Views.

The following image shows the same curved wall with three different Shading Contrasts (combined using a separate graphics program). Notice how the lowest contrast at the top appears almost flat.

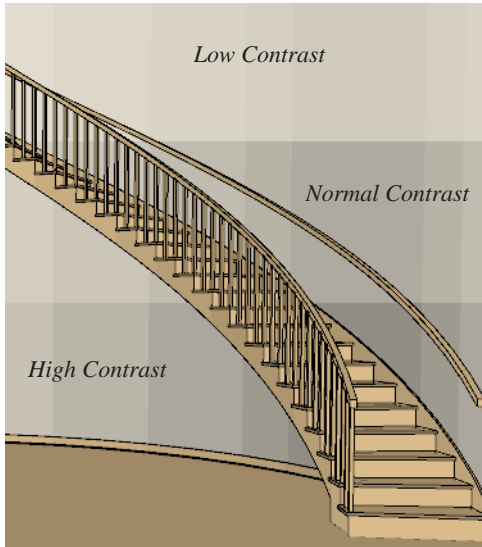

3 Specifications -

- Select a material **Type** from the drop-down list. The selected Type defines how - or whether - the material is calculated in the Materials List and may also be associated with a pattern. See “Material Types” on page 640.

Depending on the Type selected, additional settings may become available. Unless otherwise noted, these settings affect both the appearance of the material’s pattern in Vector Views and how it is counted in the Materials List:

- Specify the material’s **Height**. This value is restricted to a ratio of the Length for Parquet, Octagon, and Hexagon material

Types. When applied to a Strip, Shingles, or Shakes Type, the **Height - Overlap Amount = Exposure** of the material.

- Specify a Framing material’s **Spacing OC**. This value controls the spacing of wall studs only. See “Wall Framing” on page 436.
- Specify the material’s **Length**. This value is restricted to a ratio of the Height for Parquet, Octagon, and Hexagon material Types.
- Specify the **Thickness** of a material Type such as Tile. Thickness does not typically affect the appearance of the material in Vector Views, but is used for Materials List calculations.

Note: When a material is assigned to a wall type layer, floor or ceiling structure or finish layer, or to a structural roofing layer, the Thickness value set here is not used for materials list calculations.

- Specify the **Depth** of a Brick material. Depth does not typically affect the appearance of the material in Vector Views, but is used for Materials List calculations.
- Some patterns are defined by relative **Size**. The number does not have any units: it is more like a scaling factor. Material Types with a Size setting are not calculated in the Materials List.
- Specify the **Joint Width**, which is the grout width between pieces of Tile. This affects the size of tiles in Vector Views but not the size of the pattern lines.
- Specify the **Mortar Width** for a Brick or Block material. This affects the size of

bricks and blocks in Vector Views but not the size of the pattern lines.

- Specify the **Overlap Amt**, which is the amount that a Strip, Shingles, or Shakes material overlaps itself. The **Height - Overlap Amount = Exposure** of the material.
 - **Grouping** is used to describe the repeat of the pattern across the width of a Strip material. A 13" wide Strip with an Overlap Amt of 1" and a Grouping of 3 calculates materials based on a 12" coverage and a repeat line pattern of 4".
- 4 A preview of the material's pattern displays here. It updates as you change the material definition.

Pattern Tab

Patterns are used to represent materials in Technical Illustration and Vector Views.

Pattern Types also affect the Materials List. See "Patterns and Textures" on page 632.

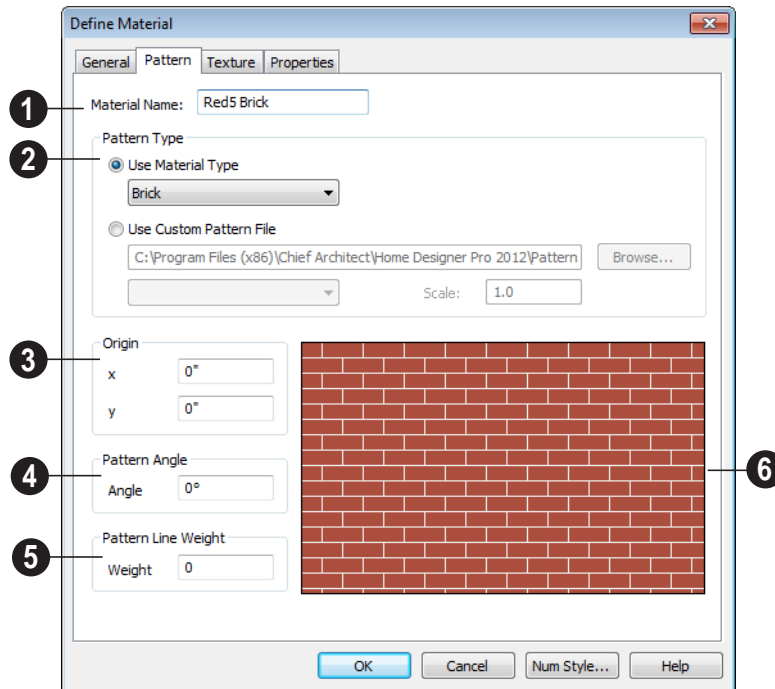

- 1 The **Material Name** displays here. You can type a different name if you wish.
- 2 Specify the selected material's **Pattern Type**. The pattern type affects both how

the material looks in Vector Views, and how it's calculated in the Materials List. See "Material Types" on page 640.

- Select **Use Material Type** to base the material's pattern on the selected Type, then select a Type from the drop-down list. This drop-down is also found on the General tab.
 - Select **Use Custom Pattern File** to specify a Custom pattern and enable the options below. When a Custom pattern is used, the material will be counted as an Area type in the Materials List.
 - The pathname of the selected **.pat** pattern file displays here.
 - Click the **Browse** to open the **Custom Pattern File** dialog and select a pattern file. This dialog is a typical Open dialog, and opens to the Patterns folder in the program installation directory.
- Select a pattern from the drop-down list. The items available depend on the **.pat** file selected above.
 - Specify the pattern's **Scale**. If the pattern displays as grey in the preview, the pattern repeats too often and this value should be increased.
- 3 Specify a new **Origin**, if needed, so the pattern displays correctly on surfaces in Vector Views.
 - 4 Specify the **Pattern Angle**, in degrees measured counterclockwise.
 - 5 Specify the **Pattern Line Weight**, which is the thickness of the lines that form the pattern.
 - 6 This is a preview of the material as it appears in Vector Views. The preview updates as changes are made.

Texture Tab

In most Rendering Techniques, materials are represented by textures. See "Rendering Techniques" on page 710.

Transparency information may be contained on the alpha channel of a texture; if so, it is used in rendered views.

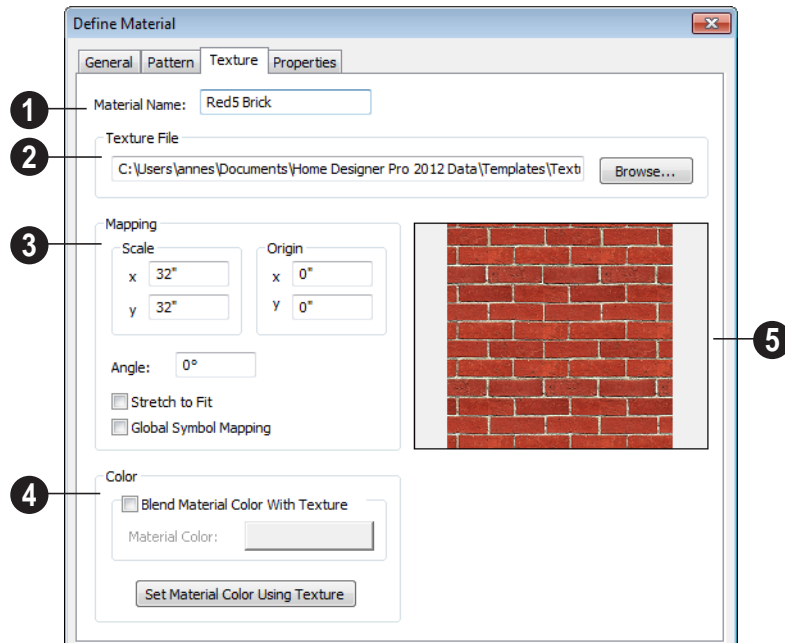

1 The **Material Name** displays here. You can type a different name if you wish. Renaming the material does not create a new material: it redefines the existing material.

2 **Texture File** - Displays the path and file name of the selected texture.

- Click the **Browse** button to browse to a texture file saved on your computer. Supported file formats are **.jpg**, **.bmp**, **.png**, **.gif**, **.tif**, **.pcx**, **.tga**. See “Creating Materials” on page 637.

3 Adjust the **Mapping** of the selected material’s texture. See “Mapping Patterns and Textures” on page 638.

- Adjust the **Scale**, or height and width ratio, of the selected texture. The values are in inches (or mm).

In this example, the texture shown is mapped to a 32” x 32” area. If a rendered surface is larger than this area, the surface has “tiles” of the texture that are 32” x 32”. If it is smaller, only a portion of the texture is shown.

- Set a new **Origin**, if needed, so the texture displays correctly on surfaces in rendered views.
- Specify the **Angle** of the texture on the surfaces of objects, in degrees.
- Check **Stretch to Fit** to stretch the texture image to cover each surface it is applied to.

Note: Changing the scale or selecting Stretch to Fit can cause textures to appear distorted if applied to a surface with a different aspect ratio than the original texture image.

- Check **Global Symbol Mapping** to map the texture using the same origin on all objects. When unchecked, the origin is defined individually for each object. See “Mapping Patterns and Textures” on page 638.

4 Specify the characteristics of the **Color** applied over the selected material’s texture.

- Check **Blend Color and Texture** to blend the texture with a solid color, then click the **Material Color** button to specify the color you want to blend it with.

When a new material is created using the **Blend Colors With Materials**  tool, the resulting material has this box checked. See “Blend Colors With Materials” on page 633.

- Click the **Set Material Color Using Texture** button to use the original color of the material’s texture. See “Patterns and Textures” on page 632.

5 A preview of the selected texture as it appears using the Standard Rendering Technique displays here. As the settings are changed, the preview updates.

Properties Tab

The Properties tab controls how the material appears in most rendered 3D views. The preview on the right displays the material rendered on a 3’ x 6’ panel using the Standard Rendering Technique. As the settings are changed, the preview updates.

A material’s rendered appearance is also affected by the Render settings in the

Preferences dialog and the lights that have been placed in the model. See “Light Types” on page 705.

To get special lighting effects on an object, use at least one point or spot light. For these highlights to appear on large flat surfaces, select **Use Triangles** in the **Preferences** dialog. See “Render Panel” on page 86.

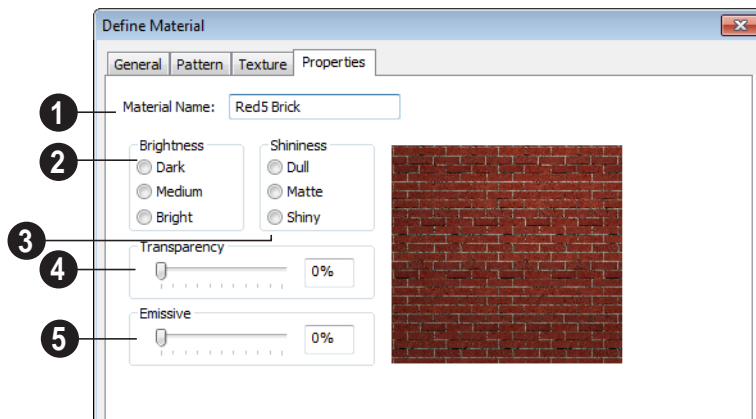

1 The name of the material displays here.

2 **Brightness** controls how bright the material appears. It can be used to get the desired appearance relative to other materials being used.

3 **Shininess** controls the sheen of the material when it is rendered with a point or spot light source on it. Shiny materials appear to have a bright white spot on them which simulates reflection of light.

4 **Transparency** - Use the slider bar or text field to control the materials transparency. A value of 0 is completely opaque and a value of 100 is completely transparent. Specifying materials with

transparency can slow down rendering speed in some situations.

5 **Emissive** - Use the slider bar or text field to control how bright a material appears independent of the lighting in the scene. It can be used to simulate surfaces that are glowing with their own light, such as the glass on a light fixture.

Manufacturer Tab

If the selected material was copied from the Manufacturer library category, the Manufacturer tab lists contact information. See “Manufacturer Catalogs” on page 610.

Material Defaults



Most objects in the program have defaults dialogs which allow you to set up a variety of attributes, including materials, before the objects are created. Default Settings are accessed by selecting **Edit> Default Settings**. See “Preferences & Default Settings” on page 55.

Not all objects, however, have default settings that can be accessed prior to being placed. Garage doors, for example, do not have a defaults dialog. Instead, you can specify the materials for them in the **Material Defaults** dialog. Once a garage door is created, you can change its materials.

Select **Edit> Default Settings**  from the menu, select “Materials”, and click the **Edit** button to open the **Material Defaults** dialog.

Material Defaults Dialog

The settings here are similar to those on the Materials tab found in object specification

dialogs throughout the program. See “Materials Tab” on page 635.

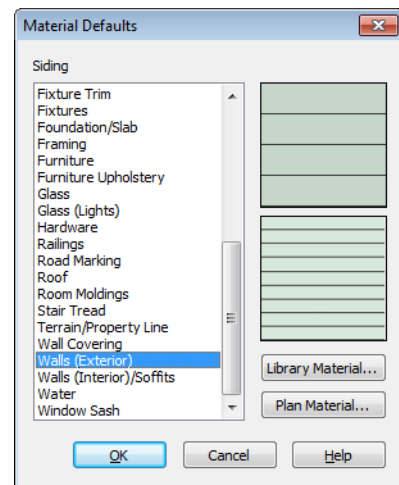

- Select a category from the scrollable list.
- Click the **Library Material** button or either preview box to open the **Select**

Library Object dialog. See “Select Library Object Dialog” on page 622.

- Click the **Plan Material** button to open the **Plan Materials** dialog. See “Plan Materials Dialog” on page 643.

Color Chooser Dialog



The **Color Chooser** dialog is opened by selecting **Tools> Color Chooser** or

by clicking on the color bar that can be found in many dialogs throughout the program.

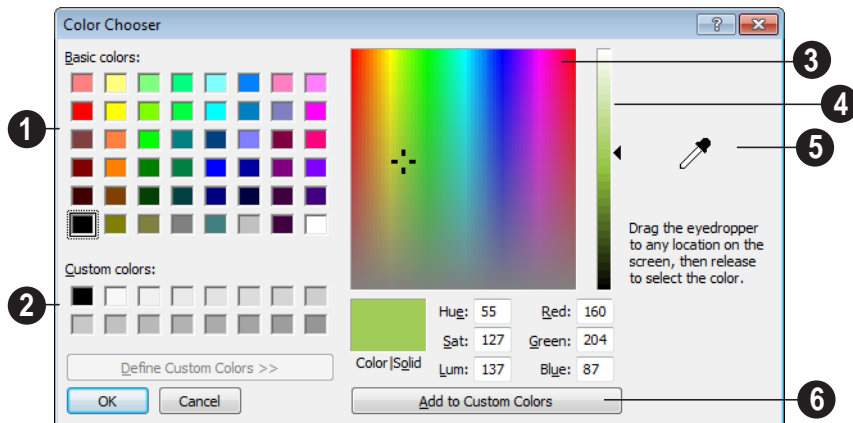

- 1 Click in any one of the **Base colors** boxes to select it as the new color.
- 2 Click in one of the **Custom colors** boxes to either select it as the new color or to specify it as the box for a new custom color to be defined.
- 3 Click anywhere in the color palette area to dynamically choose a color. The location of a selected color is identified by a black crosshairs.
- 4 Click anywhere in the vertical bar to adjust the selected color’s darkness.

- 5 Drag the **Color Chooser Eyedropper** anywhere on your monitor and release the mouse button to select the color displaying at that location.

 You can select a color from any program window. Before opening the Color Chooser dialog, make sure the desired color can be seen onscreen by tiling Home Designer Pro and the other program window.

- 6 Click **Add to Custom Colors** to add the color to selected Custom Colors box.

Zoom & View Tools

Use the Zoom tools to position the current view. To work on a specific area, you may need to zoom in so that the entire screen is filled by only a single room. At other times you may need to view the entire plan.

One layout file can be open at a time, but there is no limit to the number of plan files that can be open. The name of the file and the type of view displays at the top of each view window in its title bar. If the view is saved, its name also displays.

There are a number of ways to pan across the screen, shifting the visible part of the plan slightly while still maintaining the same zoom factor.

Multiple views of one or more open files also can be arranged and managed using the View tools.



Chapter Contents

- Zoom Tools
- Undo Zoom
- Fill Window
- Panning the Display
- Swapping Views
- Window Menu Tools
- Cascade
- Tiling Views
- Arrange Icons
- Aerial View
- Closing Views

Zoom Tools



Zoom is used to magnify any given area on the plan or 3D view. Select **Window> Zoom**, then click and drag a marquee around an area on screen. When you release the mouse, the selected area expands to fill the screen.

When the zoom is complete, whatever tool was active prior to selecting the **Zoom**  tool automatically becomes active again. If another zoom is needed, click the **Zoom**  tool again.



Zoom In - Click to zoom in towards the screen center by a factor of two.



Zoom Out - Click to zoom out from the screen center by a factor of two.



Undo Zoom - Reverse the last zoom operation. See .



Fill Window - Fits all visible items on screen. See .



Fill Window Building Only - Fits all walls and railings on the current floor on screen.



Pan Window - Move the display without changing the zoom factor. See .



Select **Window> Aerial View** to open the aerial view window. See “Aerial View” on page 660.

Zooming With the Mouse Wheel



Use the mouse wheel to zoom in and out in plan and 3D views. Scrolling the mouse wheel one click up or down zooms in or out, centering on the location of your pointer and changing the zoom by about 10%.

Note: Depending on the configuration of your mouse, it may be necessary to hold down the Ctrl key while turning the mouse wheel. If zooming in and out are not working correctly, contact the manufacturer of your mouse and mouse driver for their assistance.

Zooming in 3D Views

Zooming in 3D views does not change the camera's location or field of view. Instead, the extents of the view are expanded or cropped. You can alternatively set cameras to zoom by adjusting their Field of View. See “Render Panel” on page 86.

Undo Zoom



Select **Window> Undo Zoom** to reverse the last zoom operation.

Note: Undo and Redo do not affect zoom.



Zoom 

and **Undo Zoom**  are also available through the contextual menu. See “Contextual Menus” on page 30.

Fill Window

 In floor plan view or a cross section/elevation view, select **Window > Fill Window** or press the **F6** key to view nearly everything on screen that is visible, including the Reference Display. CAD Points are the only objects that are not included when Fill Window is used.

If you are zoomed in so that only a portion of the drawing displays on screen, selecting **Fill**

Window  zooms out so that the entire view fits on the screen. If you are zoomed out so that the entire drawing is smaller than the screen, selecting **Fill Window**  zooms in until the drawing fills the screen.

When the drawing sheet is shown, **Fill Window**  zooms to the sheet borders.

Fill Window Building Only

 **Window > Fill Window Building Only** is similar to **Fill Window**, but zooms in or out so that all walls and railings in the view fill the current window. Other objects are ignored.

In 3D Views

Fill Window  and **Fill Window Building Only** 

behave slightly differently in perspective and orthographic 3D views. In perspective views, the original zoom factor is restored, while in orthographic views the camera's Field of View is adjusted so that all surfaces in the 3D view are included.

Panning the Display

There are four ways to pan the display without changing the zoom factor.

Using the Scroll Bars

One method is to use the scroll bars on the right and bottom edges of the window.

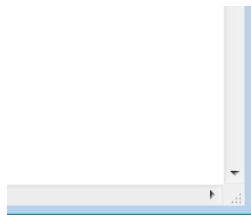

- Drag the square button in the bar itself in order to pan a larger distance.

- Click the end arrow keys on the scroll bars to shift the display in 12" increments.
- The 12" increment is defined in the **Plan Defaults** dialog under **Inches Scrolled by Arrow Key**. See “General Plan Defaults Dialog” on page 58.

Using the Arrow Keys

In floor plan view, the arrow keys on the keyboard work exactly like clicking the arrow buttons on the scroll bar. They shift the display according to the number of inches defined in the **Plan Defaults** dialog.

Using the Mouse



If you have a wheel mouse, you can pan the display by pressing the middle mouse button, or wheel, and moving the mouse in the direction you would like to pan. When the middle mouse button is held down, the pointer changes to a hand  icon.

Mouse drivers sometimes have other functions assigned to the wheel and buttons. These override the Home Designer Pro setting.

Using the Pan Window Tool







The **Pan Window** tool works much like the mouse wheel method.

- Select **Window> Pan Window** . The pointer changes to a hand  icon. Click and drag in floor plan view to pan the window. The command is invoked once and the program reverts to the previously active tool when you release the mouse button.
- Double-click the **Pan Window**  tool and the command remains active.

Swapping Views

There are several ways to switch between open view windows.

- Select **Window> Swap Views**  or press F7 to switch between the two most recent views.
- The **Swap Views**  button toggles between the current view and the view that was current before it.
- Select **Window> Next Window**  or **Window> Previous Window**  to cycle through all open views in the order you prefer.

- Press the Ctrl + Tab (Next Window) or Ctrl + Shift + Tab (Previous Window) keys to cycle through all open views.
- A list of all the views currently open is located at the bottom of the Window menu. Each view is identified by its name and what type of view it is. Select one to go directly to that view.

Window Menu Tools

Select **Window** from the menu to access the Window Menu tools, which help you display multiple view windows of your model at the same time.

Note: The Window Menu Tools button does not display on the toolbar by default but it can be added. See “Toolbar Customization Dialog” on page 93.

 Select **Window> Cascade** to cascade all open views. See “Cascade” on page 657.

 Select **Window> Tile Horizontally** or **Tile Vertically** to tile all open views. See “Tiling Views” on page 659.

 Select **Window> Arrange Icons** to arrange all open views that are currently minimized. See “Arrange Icons” on page 660.

 Select **Window> Next Window** to switch to the next open view. See “Swapping Views” on page 656.

 Select **Window> Previous Window** to switch to the previous open view. See “Swapping Views” on page 656.

 Select **Window> Show Layout** to switch to the layout file. Only available if a layout file is currently open. See “Layout” on page 863.

Open View Windows

One layout file can be open at a time, but there is no limit to the number of plan files that can be open. The name of the file and the type of view displays at the top of each view window in its title bar. If the view is saved, its name also displays.

There is no limit to the number of 3D view windows that you can have open at a given time; bear in mind, though, that each window demands use of your computer’s resources and that you may see poor performance if too many views are open. See “3D Views” on page 663.

A list of all view windows currently open displays at the bottom of the Window menu. Each view is identified by its name and what type of view it is. A checkmark is beside the view that is currently active. Select one to go directly to that view.

The names of up to eight views can display here. If more than eight view windows are open, **More Windows** is the last item in the menu. Select this option to open the **Select Window** dialog.

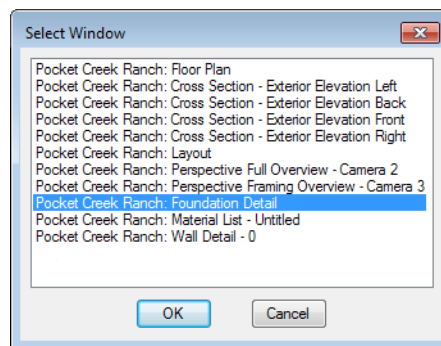

Select the name of a view from the list and click **OK** to make it the active view.

Cascade

 Select **Window> Cascade** to cascade all open views. Cascade is a Windows function which allows you to organize open

windows in a cascading pattern. Click on any visible edge to activate that window.

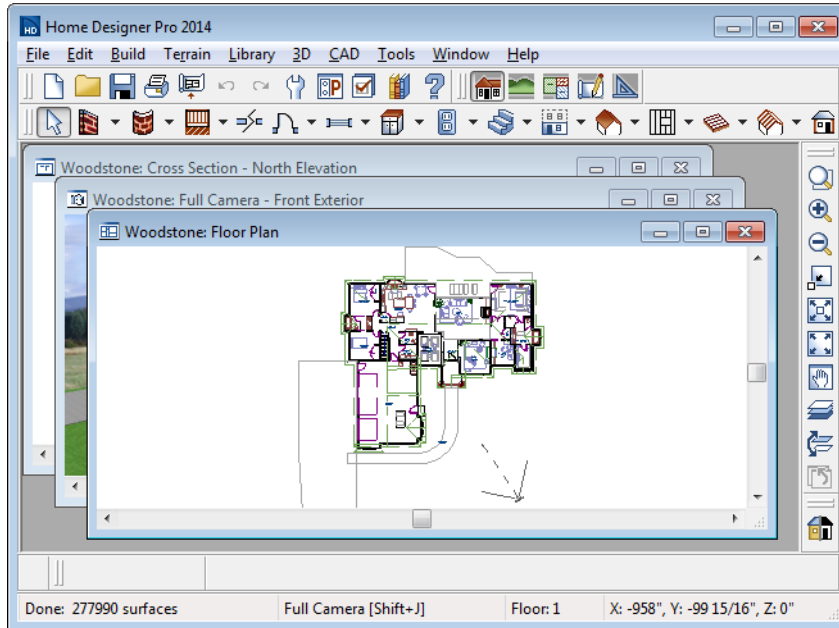

Tiling Views

 The window tiling options allow you to display multiple views side by side in the Home Designer Pro window.

Select **Window> Tile Horizontally**  to display both views in a horizontal orientation.

Select **Window> Tile Vertically**  or press Shift + F6 on the keyboard to display both views in a vertical orientation.

To activate a view, click on its title bar or anywhere in the view window. Note that any changes you make are reflected in other views as well.

To end window tiling, click the **Maximize**  button in the upper right corner of any open view.

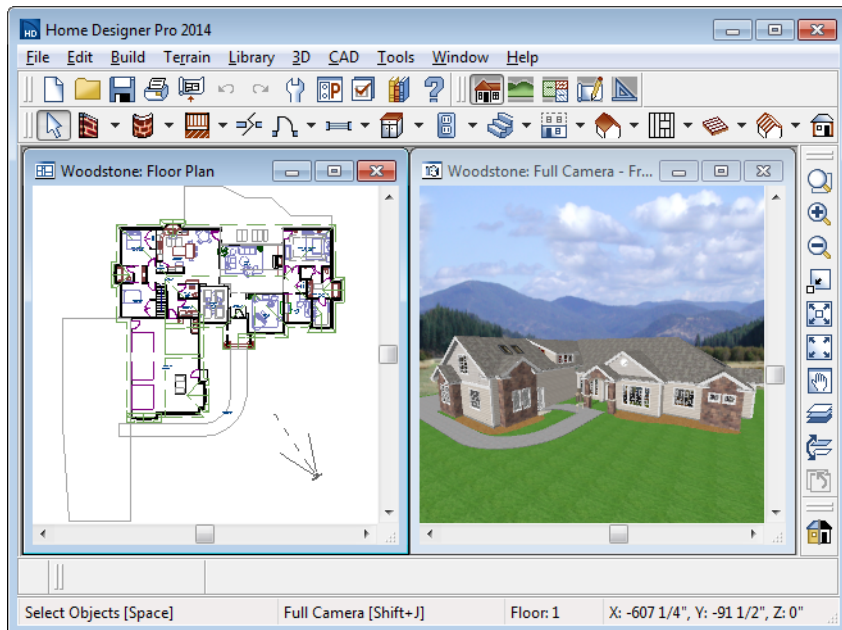

Tiling allows you to see the results of changes in floor plan view in 3D or vice

versa, and can also be useful for copying objects from one plan to another.

Arrange Icons



Arrange Icons is a Windows function used when several active windows have been minimized. Select **Window> Arrange Icons** to align the minimized title

bars in a row at the bottom of the working desktop. You can then click the minimized title bars to reactivate them or use them for swapping and closing views.

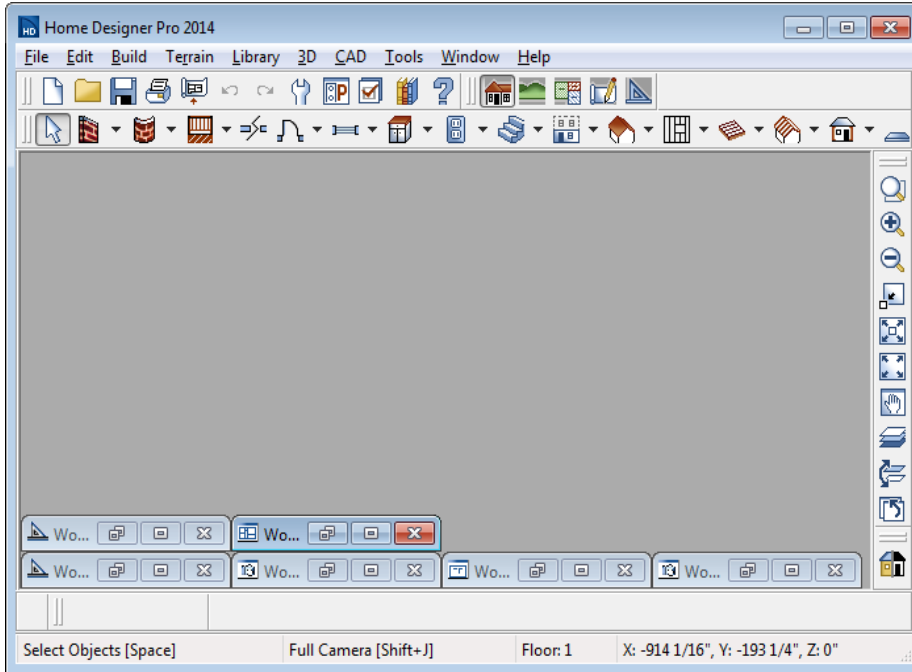

Aerial View



In floor plan view, select **Window> Aerial View** to open the **Aerial View** window.

The Aerial View window shows everything on the current floor as well as a marquee indicating the portion currently visible in the floor plan view window.

As you pan around the floor plan view window or zoom in or out, the marquee in Aerial View moves and resizes to reflect these changes. This can make it easier to navigate in floor plan view.

The Aerial View window is initially docked on the right side of the window, but it can be moved to any other edge or allowed to float.

The Aerial View always displays the entire plan, so it has no scroll bars.

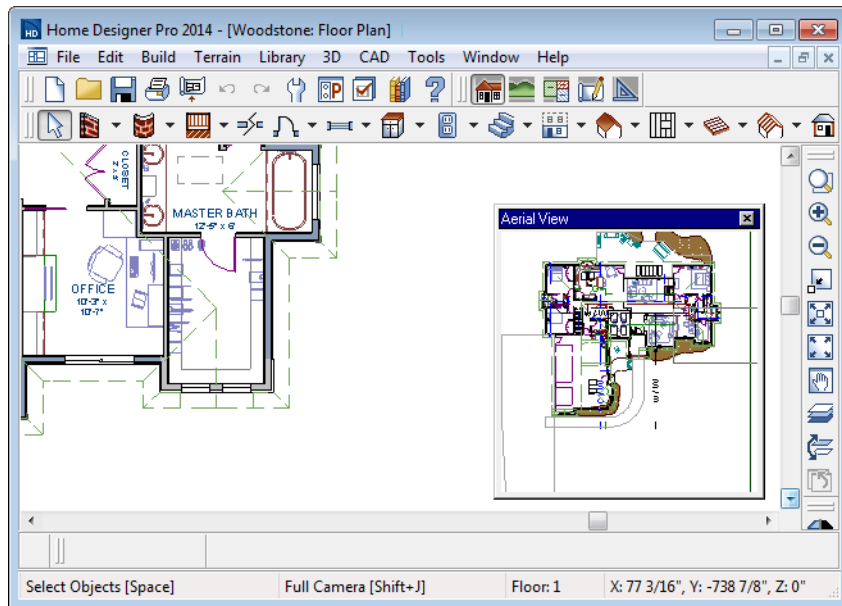

The border that displays in the aerial view window coincides with the floor plan view display.

- The Aerial View window can be moved by clicking and dragging the grip bar and resized by clicking and dragging an edge.
- The grey marquee that displays in the Aerial View represents the extent of the floor plan view. This marquee updates if you zoom or pan in floor plan view.
- Use the left mouse button to drag a new marquee within the Aerial View window. The floor plan view updates to match.
- Use the right mouse button to pan the existing marquee within the Aerial View window. The floor plan view updates to match.
- No matter what tool is active, when you move the pointer to the Aerial View window and drag a marquee, the floor plan view zooms in on that area.

Closing Views

Select **File > Close** or click the **✕** at the top right corner of a window to close it. If the

view is still needed, swap to a different view without closing the current views.

3D Views

Little preparation is needed to create a 3D view of a model: simply click a button to create an overview or click and drag to create a camera or cross section/elevation view.

To improve the quality of the rendering and create a custom look, you can adjust lighting and edit the materials used in the plan. You can create Final views that are even more realistic. See “3D Rendering” on page 697.

Many objects can be placed and edited in 3D views, and any camera view or overview can be saved or even used to record a walkthrough. See “Pictures, Images, & Walkthroughs” on page 805.

Chapter Contents

- OpenGL and Hardware
- Types of 3D Views
- Defaults and 3D Preferences
- Camera Defaults Dialog
- 3D View Defaults Dialog
- 3D View Tools
- Creating Camera Views
- Creating Overviews
- Cross Section/Elevation Views
- Displaying 3D Views
- Repositioning Cameras
- Editing 3D Views
- Cross Section Slider
- Working in 3D
- Saving & Printing 3D Views
- Camera Specification Dialog
- Cross Section/Elevation Camera Specification

OpenGL and Hardware

Home Designer Pro features a built in, easy to use rendering engine that makes use of OpenGL rendering technology, which has good hardware support on most video cards.

To take full advantage of the rendering capabilities of Home Designer Pro, a graphics card that supports OpenGL hardware acceleration and has at least 256 MB of dedicated video memory is highly recommended. For complex models, an accelerated card generates quality renderings in seconds that might otherwise take minutes or even hours with a non-accelerated card or chipset.

OpenGL is required in order to use the stylized Rendering Techniques. See “Rendering Techniques” on page 710.

- Standard rendering requires OpenGL 2.0 when **Use Enhanced Lighting** is checked in the **Preferences** dialog. See “Render Panel” on page 86.
- Technical Illustration rendering requires OpenGL 2.0.
- Watercolor rendering requires OpenGL 1.5.

Types of 3D Views

There are three categories of 3D views in Home Designer Pro: camera views, overviews and cross section/elevation views. Each of these view types can be generated using a variety of rendering techniques. See “Rendering Techniques” on page 710.

Every 3D view is also either orthographic or perspective in nature. Cross section/elevation views are always orthographic while camera views are always perspective. You can choose to generate overviews as either orthographic or perspective.

Perspective and Orthographic Views

Perspective views have a focal, or vanishing, point. Surface edges and lines that would be parallel in real life appear to converge towards that focal point, and objects closer to

the camera appear larger while objects farther from the camera appear smaller.

Orthographic views do not have a focal or vanishing point. Parallel surface edges and pattern lines appear parallel in these views and objects appear to be the same size regardless of their distance from the camera.

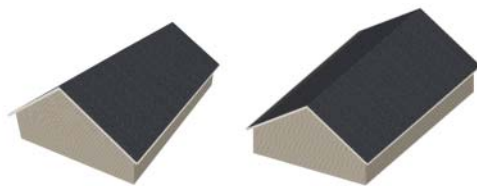

Perspective Overview *Orthographic Overview*

Perspective views display 3D objects much the way that they appear to the eye in real life, so they are ideal for presentation views.

By default, perspective views are created using the Standard rendering technique.

Orthographic views, on the other hand, are useful for technical drawings. By default, orthographic views are created using the Vector View technique.

Rendered and Vector Views

3D views can be generated using a variety of different rendering techniques. See “Rendering Techniques” on page 710.

Most rendered views represent materials using textures. Surface edge lines are generally not drawn and lighting is often modeled, creating results that range from a photorealistic appearance to artistic painting styles.

Vector Views are non-photorealistic views in which objects are drawn using surface edge lines, or vectors. Lighting is not calculated, and materials are represented using pattern lines and solid colors, making Vector Views quicker to generate and ideal for layout drawings and high resolution printing.

Defaults and 3D Preferences

There are a number of defaults and preference settings that allow you to control the initial characteristics of 3D views.



Camera positioning, field of view and related initial settings for camera views are specified in the **Camera Defaults** dialog. See “Camera Defaults Dialog” on page 665.



Ambient lighting settings, 3D backdrop information, and other settings that affect 3D views as they are generated are found in the **3D View Defaults** dialog. See “3D View Defaults Dialog” on page 668.



Which objects display in a 3D view and which do not is controlled in the

Layer Display Options dialog. See “Displaying Objects” on page 102.



3D views can be generated using any of the **Rendering Techniques**. See “Rendering Techniques” on page 710.



The initial settings for each Rendering Technique can be set in the **Rendering Techniques Defaults** dialog. See “Rendering Technique Options” on page 713.



The Render panel of the **Preferences** dialog controls settings for Render Previews and Final Views. See “Render Panel” on page 86.

Camera Defaults Dialog



Default Settings can be accessed by selecting **Edit> Default Settings** or by double-clicking either **Perspective View**

Tools parent button or any Camera toolbar button.

The settings in the **Camera Defaults** dialog affect how a camera clips, captures and renders views, how it displays in floor plan view, how it is positioned, and how it moves.

Once a camera is created, these settings can be customized in the **Camera Specification** dialog. See “Camera Specification Dialog” on page 691.

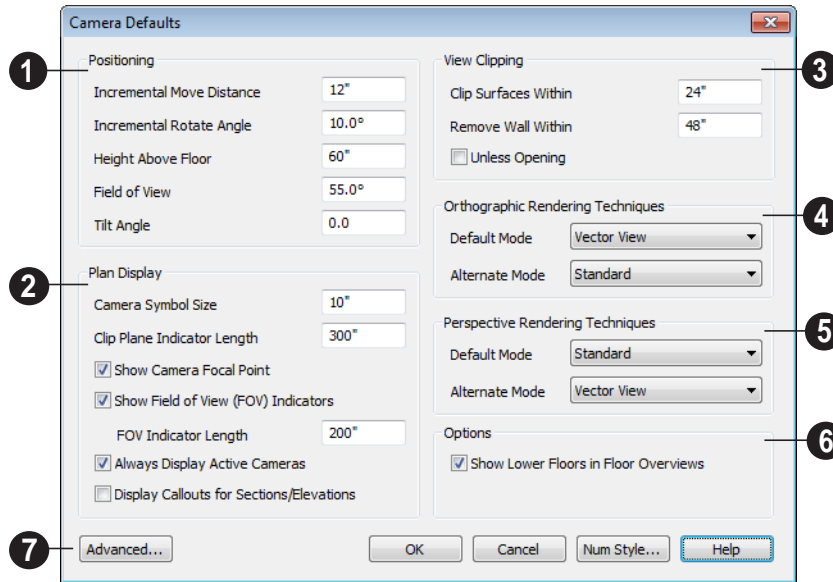

1 The **Positioning** settings control the position and orientation of the camera. See “Repositioning Cameras” on page 680.

- The **Incremental Move Distance** controls how far the camera moves each time you Pan in any direction or Dolly forwards or backward. For interior views a small number is good, but for exterior you may want a larger increment.
- The **Incremental Rotate Angle** defines how many degrees the camera rotates each time you Tilt, Orbit, or Dolly side to side. A setting of 90° would make one full rotation in four moves.
- The **Height Above Floor** defines the height that the camera is above the floor level for the current floor.

- The **Field of View** defines the camera’s field of vision in angular degrees.
- The **Tilt Angle** is the camera’s angle relative to the horizon. 0° is horizontal, 5° points slightly upward, and -5° points slightly towards the ground.

2 The **Plan Display** settings control the appearance of the camera’s symbol in floor plan view. See “Using the Edit Handles” on page 685.





- Specify the **Camera Symbol Size**, measured in plan inches (mm). This is also the default size for Walkthrough Path Key Frames. See “Walkthroughs” on page 819.

- Set the **Clip Plane Indicator Length** for Cross Section/Elevation, Backclipped Cross Section, and Wall Elevation camera symbols. The length is measured in plan inches (mm). See “Cross Section/Elevation Views” on page 675.
 - Check **Show Camera Focal Point** to display the camera’s focal point in floor plan view.
 - Check **Show Field of View Indicators** to display the field of view indicator for cameras in floor plan view. You can also change the **FOV Indicator Length**, which is measured in plan inches (mm).
 - Uncheck **Always Display Active Cameras** to turn off the display of active camera symbols when the “Cameras” layer is turned off. When checked, active cameras always display, regardless of the layer setting.
 - Check **Display Callouts for Sections/Elevations** to represent cross section/elevation cameras in floor plan view using callouts instead of camera symbols. See “In Floor Plan View” on page 677.
- 3 The **Wall and Surfaces** settings determine the extent of camera views.
- **Clip Surfaces Within** - Specify that the camera does not display an object within this distance.
 - **Remove Wall Within** - Remove the display of walls within this distance of the camera.

Both of these distances are measured as a radius from the camera position.

- Check **Unless Opening** to display a wall that is inside the **Remove Wall Within**

range if the camera is pointing through an opening such as a door or window.

- 4 **Orthographic Rendering Techniques** - Specify which Rendering Techniques are used to create Orthographic 3D views. See “Rendering Techniques” on page 710.
- Select a Rendering Technique from the drop-down list to be used when the **Default Mode**  is active. See “Edit Behaviors” on page 120.
 - Select a Rendering Technique from the drop-down list to be used when the **Alternate Mode**  is active.
- 5 **Perspective Rendering Techniques** - Specify which Rendering Techniques are used to create Perspective 3D views. See “Perspective and Orthographic Views” on page 664.
- Select a Rendering Technique from the drop-down list to be used when the **Default Mode**  is active.
 - Select a Rendering Technique from the drop-down list to be used when the **Alternate Mode**  is active.
- 6 Uncheck **Show Lower Floors in Floor Overviews** to show only the current floor in Floor Overviews. When checked, the current floor plus any floors beneath it are shown. See “Doll House View” on page 675.
- 7 Click the **Advanced** button to open the **Advanced Camera Options** dialog and specify how hidden lines are removed when OpenGL is not used. See “OpenGL and Hardware” on page 664.

Advanced Camera Options Dialog

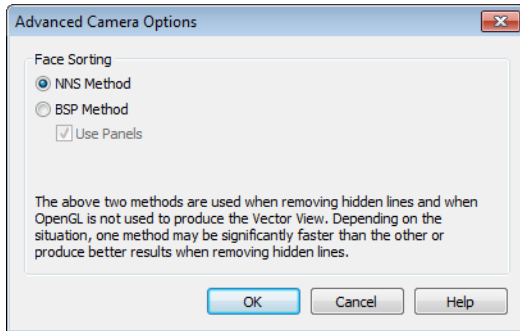

- Select **NNS Method** to use Home Designer Pro's default method. In most cases, this method is both faster and requires less memory than the BSP Method.
- Select **BSP Method** to use an alternative method. This method may provide better results in some situations; however, it may be slower and require more memory.
- When the BSP Method is used, checking **Use Panels** may increase speed and reduce memory usage.

3D View Defaults Dialog



Select **3D > 3D View Defaults, Edit > Default Settings** , or double-click the **Perspective View Tools**  parent button to display the **3D View Defaults** dialog.

Some settings in the **3D View Defaults** dialog affect rendered views, some affect Vector Views, and some affect both view types. See “Rendered and Vector Views” on page 665.

Options Tab

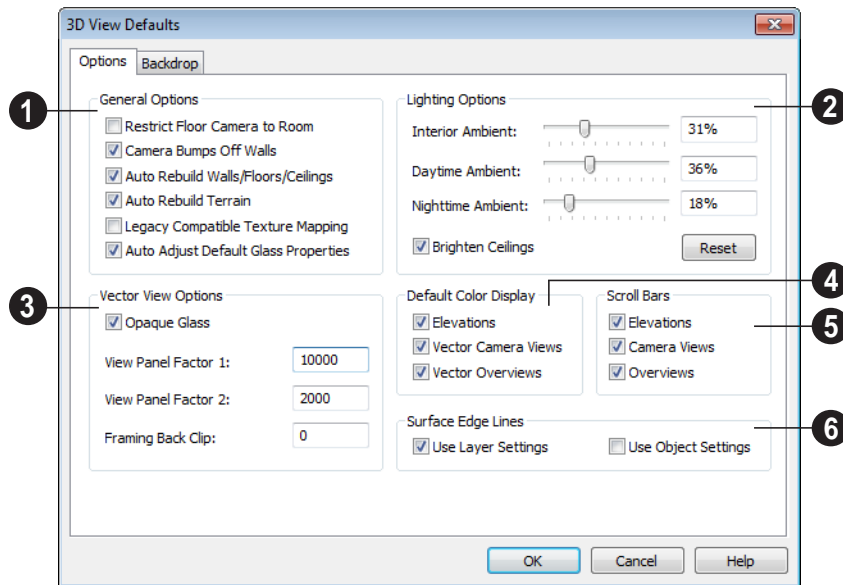

- 1** The **General Options** affect all 3D views.
- Check **Restrict Floor Camera to Room** to suppress the generation of objects outside the room in which a Floor Camera is created. Only affects subsequently generated Floor Camera views. See “Camera Views” on page 672.
- When checked, a view through a doorway into another room shows only blank space or the selected 3D backdrop. Use this option to reduce 3D view rendering time or to minimize file size when creating a single room 3D Walkthrough.
- Uncheck **Camera Bumps Off Walls** to allow cameras to move freely through walls.
 - Check **Auto Rebuild Walls/Floors/Ceilings** to automatically rebuild floors and

ceilings before a 3D view or elevation is displayed. When this is unchecked and the structure is not up to date, the Rebuild Walls, Floors, Ceilings  icon displays near your mouse pointer. See “Rebuilding Walls, Floors & Ceilings” on page 324.

- Check **Auto Rebuild Terrain** to automatically rebuild terrain to reflect recent changes before generating a 3D view. If this option is unchecked and the terrain is not up to date, the Rebuild Terrain  icon displays near your mouse pointer. See “Building the Terrain” on page 552.
- Check **Legacy Compatible Texture Mapping** to use global texture mapping settings rather than texture mapping fixed to individual objects.



Legacy Compatible Texture Mapping should remain unchecked except in legacy plans with custom rotated textures.

- When **Auto Adjust Default Glass Properties** is checked, the program automatically adjusts the behavior of window, door, and electrical fixture glass in Standard rendered and ray trace views in response to interior and exterior lighting conditions. When this box is unchecked, these adjustments are not made.

2 The **Lighting Options** control the ambient light in rendered views. Click and drag the slide bar or type in a percent value to adjust these options. See “Ambient Light” on page 699.

- **Interior Ambient** affects interior views.
- **Daytime Ambient** affects daytime exterior views.
- **Nighttime Ambient** affects nighttime exterior views.
- Click the **Reset** button to restore initial default values.
- Uncheck **Brighten Ceilings** to turn off the default parallel light source that shines upward in interior views to add extra illumination to ceilings. See “Default Lights” on page 700.

3 The **Vector View Options** only affect views using the Vector View rendering technique. See “Rendered and Vector Views” on page 665.

- Check **Opaque Glass** to make the glass in windows and doors opaque in Vector Views. When unchecked, window and door glass is completely transparent.

- **View Panel Factors** adjust the performance of Vector Views. Normally, these values should not need changing, but you may be able to get modest performance improvements by trying other values. See “Speeding up 3D View Generation” on page 716.

- **View Panel Factor 1** determines how many surfaces are drawn for each horizontal panel. Each horizontal panel is then subdivided into vertical panels - and **View Panel Factor 2** determines how many surfaces are contained in each vertical panel.

- View panel factors represent target numbers of surfaces to use in defining each panel. A value of 10000 for Factor 1 means that a total of 10,000 or more surfaces are collected to define each panel vertically. A value of 2000 for Factor 2 means that 2,000 or more surfaces are collected to define panels horizontally.

- Making these numbers larger results in fewer panels; making them smaller results in more panels. Adjusting these numbers either too low or too high causes the time required to draw to increase.

- **Framing Back Clip** defines the back clip for framing members in cross section views. Framing must be set to display to see the effects of this value. A zero value does not back clip at all.

4 **Default Color Display** controls whether views created using the Vector View rendering technique are generated using color or not. See “Rendering Techniques” on page 710.

- Select a check box to generate that view type in color or uncheck to generate that view type as a line drawing.

- A colored view can always be changed to a line drawing and vice versa by choosing **Tools> Color Off/Color On** .
 - Check **Use Layer Settings** to display surface edge lines for objects using the display settings specified by layer in the **Layer Display Options** dialog.
 - If this option is not checked, all edge lines are drawn black and solid with a line weight of 0.
 - If **Use Layer Settings** is checked you can also check **Use Object Settings**. All objects that have special settings specified on the Line Style tab of their specification dialog display using those settings, overriding the layer settings in the **Layer Display Options** dialog.
- 5 The **Scroll Bars** check boxes control the display of scroll bars along the right side and bottom of each view window. Clear a check box to suppress the scroll bar in that view type and yield more viewing area.
- When the scroll bars are suppressed, you can use the keyboard arrow keys to scroll. To pan the display, hold the key and drag the pointer across the window. See “Panning the Display” on page 655.
- 6 Specify how the **Surface Edge Lines** display for all objects in 3D views.

Backdrop Tab

The settings on the Backdrop tab allow you to specify a backdrop image or color to

display behind your model in 3D views. See “3D Backdrops” on page 679.

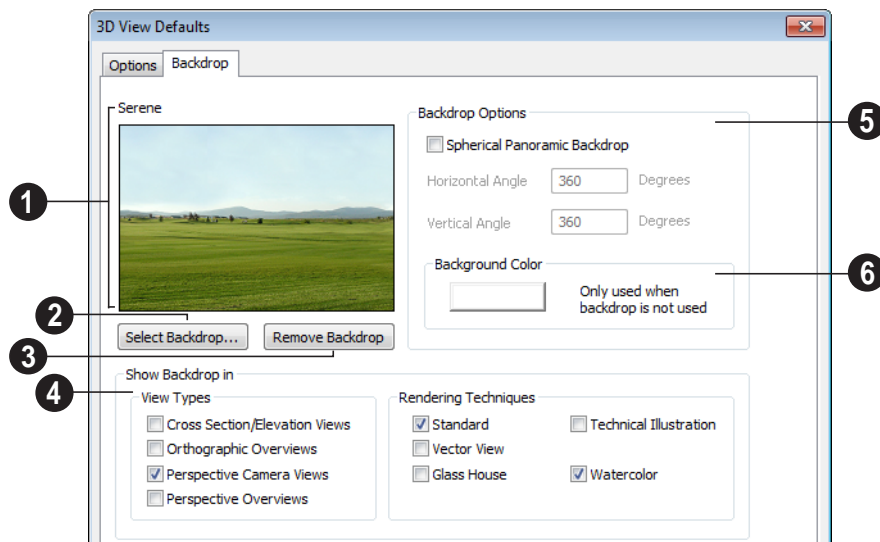

- 1 A preview of the selected backdrop is shown here, and its name displays for reference directly above.

- 2 Click **Select Backdrop** to open the **Select Library Object** dialog and choose a backdrop image from the library. See “Select Library Object Dialog” on page 622.
- 3 Click **Remove Backdrop** to use a solid color instead of a backdrop image. The color used is defined in the **Background Color** section of this dialog tab.
- 4 The **Show Backdrop in** options let you specify the conditions under which the selected backdrop image displays.
 - Specify in which **View Types** a backdrop image is used. By default, only Perspective Camera Views are set to use a backdrop. See “3D View Tools” on page 672.
 - Specify in which **Rendering Techniques** a backdrop image is used. See “Rendering Techniques” on page 710.
- 5 **Backdrop Options** can be used to create spherical panoramic backdrops.
 - Check **Spherical Panoramic Backdrop** to place the selected backdrop onto a sphere that surrounds your model in camera views and overviews.

- The **Horizontal Angle** controls how many times the backdrop appears as you rotate in a full circle from side-to-side. A value of 360° makes the backdrop wrap around the scene once. A value of 720° makes it wrap around the scene twice. 180° makes only half the backdrop wrap around the scene.
- The **Vertical Angle** determines how much of the backdrop stretches up-and-down. To have the backdrop stretch from the highest point in the sky to the lowest point in the ground, use a value of 180°. To have the backdrop stretch from just below a horizontal render to just above, use a smaller value such as 100°.

Some experimenting with backdrop images and **Angle** values may be necessary to achieve the desired results.

- 6 Click the color bar to select the **Background Color** that displays when a backdrop image is not being used. See “Color Chooser Dialog” on page 652.

The **Background Color** is used in all views except Vector Views, which instead use the Background Color set in the **Preferences** dialog. See “Colors Panel” on page 63.

3D View Tools



Select **3D > Create**

Orthographic View to display the Orthographic View Tools or **3D > Create Perspective View** to display the Perspective View Tools.

Camera Views

Camera views are perspective views. They are not scaled and cannot be annotated but are ideal for creating presentation views.



The **Full Camera** tool creates multi-floor views of the 3D model. It can be used to create interior and exterior perspectives, and is good for displaying

cathedral ceilings, roofs, lofts, stairwell openings, and other variation in floor and ceiling levels.



The **Floor Camera** tool creates perspective views of the current floor only. Nothing above the ceiling surface is generated, and neither is anything below the floor.

Overviews

An overview can be either orthographic in nature or perspective, depending on the tool used to create it. See “Creating Overviews” on page 674.



The **Orthographic and Perspective Full Overview** tools create views of the entire model including all floors, ceilings, and the roof.



The **Orthographic and Perspective Doll House View** tools create views of the current floor without a roof or ceiling.



The **Orthographic and Perspective Framing Overview** tools create views of the framing in the

model. Framing must be built in order for it to display in a framing overview. See “Framing Overview” on page 675.

Cross Section/Elevation Views

Cross Section/Elevation views are similar to the traditional, scaled orthographic views often used in drafting. They are scaled and can be fully annotated. See “Cross Section/Elevation Views” on page 675.



A **Cross Section/Elevation** view displays all floors of the model except floor 0. If the view is created outside the structure looking toward it, the result is an exterior elevation. If the view is created inside the structure, or passes through any of the structure, a cross section is created.



The **Backclipped Cross Section** tool includes only the objects between the starting point and stopping point of the cross section line.



The **Wall Elevation** tool creates an elevation of a wall on a single floor and in a single room. The **Wall Elevation** tool cannot be used to create exterior views.

Creating Camera Views

All full and floor camera views are created using the same method.

To create a camera view

1. In floor plan view, select the desired camera tool. The mouse pointer displays the camera  icon.
2. Click and drag a line to define the view direction.
 - Where your line begins is the camera’s position.
 - The line that you drag defines the direction the camera is pointed.
 - The end of the line is the focal point of the view, the point the camera rotates around.

- By default, the field of view is 45°, which is similar to what the human eye sees or a 50mm camera lens.

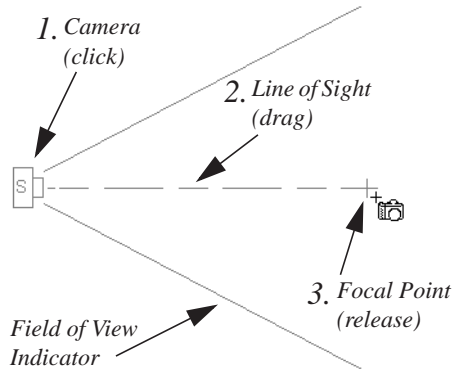

3. When you release the mouse button, a view generates in a new window.
4. Return to the floor plan view. A camera symbol now displays in floor plan view. See “Swapping Views” on page 656.

In order to create a camera view, you must click and drag at least as far as your current **Snap Distance**. See “Snap Properties Panel” on page 79.

Creating Overviews

In Home Designer Pro, there are three different overview types: Full, Floor and Framing Overviews.

Each type of overview can be generated as either an orthographic or perspective view. An overview window’s title bar indicates whether it is perspective or orthographic. See “Perspective and Orthographic Views” on page 664.

Overviews generate as soon as you select the tool and are always created at the same angle. The focal point is always located at the center of the model; however, the position of the camera will vary depending on the size of the 3D model. The larger or more spread out the model, the further away the camera will be from the focal point so that the entire model can be seen in the view.

Once generated, an overview window’s title bar indicates whether it is a perspective or

orthographic view and a camera symbol representing the overview displays in floor plan view. The overview ‘camera’ can be edited much like regular camera views can. See “Editing 3D Views” on page 684.

Full Overview



Select **3D> Create Orthographic View> Full Overview** or **3D> Create Perspective View> Full Overview** to generate an exterior view of the entire model.





Doll House View



Select **3D> Create Orthographic View> Doll House View** or **3D> Create Perspective View> Floor Overview** to create a view of the current floor with the ceiling removed and all floors beneath it visible.

Doll House Views are an effective tool for illustrating traffic flow and the relationships between spaces.



To see a different floor, select **Tools> Reference Floors> Up One Floor**  or **Down One Floor** . You can also return to floor plan view and make another floor current before generating the Doll House View.

If you prefer, you can specify in the **Camera Defaults** dialog that only the current floor be

included in Floor Overviews. See “Camera Defaults Dialog” on page 665.

Framing Overview



Select **3D> Create Orthographic View> Framing Overview** or **3D> Create Perspective View> Framing Overview** to create a view of the entire model, displaying only framing and the foundation.

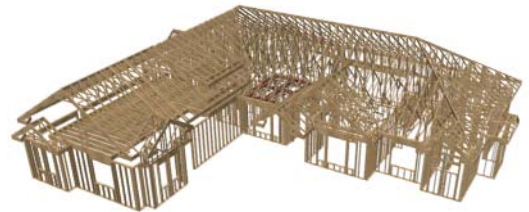

Framing overviews include all floor, wall, and roof framing as well as foundations. Unlike other overviews, which use the Camera View layer set, Framing Overviews use the 3D Framing Set. See “Layer Sets” on page 103

Framing must be built before generating this view or the view will be empty.

Cross Section/Elevation Views



The **Cross Section/Elevation**, **Back-clipped Cross Section**, and **Wall Elevation** tools produce the traditional, orthogonal views often used in drafting. Regardless of their distance from the camera, all lines and dimensions in these views are their true lengths, making it easy to accurately see the spatial relationships of the 3D objects in the model.

Cross section/elevation views can be clipped to limit how much of the model is included in the view. See “Camera Tab” on page 695.

Cross section/elevation views are the only 3D views can be enhanced with the 2D CAD tools. They can be fully annotated and dimensioned and then printed to scale.

Cross Section/Elevation Camera Tools



Each of the three cross section/elevation camera tools has a specific function.

 A **Cross Section/Elevation** view displays all floors of the model. The cross section begins at the point where the camera arrow is drawn and continues through the entire model.





 The **Backclipped Cross Section** tool includes only the objects or portions of objects between the starting point and stopping point of the camera's Line of Sight.

 The **Wall Elevation** tool creates an elevation of a single wall defining the room that the camera is drawn in. It does not cut through walls or show the ceiling, floor, or roof. It creates a 2D projection of a wall and the objects between the wall and the camera and is used primarily for kitchen and bath elevations. By default, Wall Elevations recognize room definition created by railings and invisible walls; however, you can specify This tool cannot be used to create exterior views.

Cross Section/Elevation  **Backclipped**

Cross Section  and **Wall Elevation**  views are created in the same way.

To create a Cross Section/Elevation view

1. Select the **Cross Section/Elevation** , **Backclipped Cross Section**  or **Wall Elevation**  tool. The pointer changes to a  with crosshairs marking the position of the pointer.

2. Click and drag a line in floor plan view.
 - A Camera symbol displays where you click, along with a Cross Section Line indicating the plane of the camera's cross section cut line.

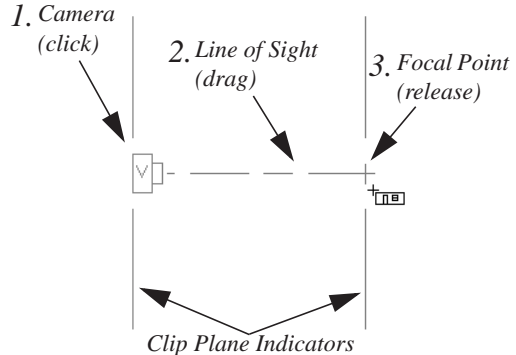

3. Drag in the direction of the Line of Sight to draw a camera arrow.
 - Always drag the camera arrow perpendicular to the wall to be viewed.
4. When you release the mouse button, the view generates in a new window.
 - If the view is a Backclipped Cross Section, a second Cross Section Line at the end of the Line of Sight indicates the furthest extent of the backclip.

As with camera views, you must click and drag at least as far as your current **Snap Distance** in order to create a Cross Section/Elevation view. See “Snap Properties Panel” on page 79.

If the Line of Sight does not cut through a 3D object and the object is within the back clipped distance, such as a window shown in elevation, the object retains its 3D definition and can be selected, moved, stretched, or otherwise modified in the view. The 3D model is updated in all views.

Detailing Cross Section/ Elevation Views



CAD objects, including Text and Dimensions, can be created in cross section/elevation views. These objects are superimposed on the view and have no effect on the 3D model itself. If CAD objects have been added to a cross section/elevation view, the program will prompt you to save the view before closing the window. This information is then stored in the view.

In cross section views, some objects, such as walls, are represented using Cross Section lines. If a dimension line finds an object surface edge represented by a Cross Section line, a Point Marker will be placed at that location, and the dimension will locate it instead of the Cross Section line. See “Markers” on page 762.

CAD objects will snap to the Snap Grid when Grid Snaps  are enabled. Note that the 3D model may obscure the display of the Snap Grid. See “Grid Snaps” on page 112.

Displaying 3D Views

A variety of tools and settings allow you to control the appearance of your 3D views. There are also numerous ways to adjust the position, focal point and field of view of a 3D view. See “Editing 3D Views” on page 684.

The name of the current plan file and the type of view displays at the top of each view window in its title bar. If a 3D view is saved, its name also displays.

There is no limit to the number of 3D view windows that you can have open at a given time; bear in mind, though, that each window demands use of your computer’s resources and that you may see poor performance if too many views are open. See “Open View Windows” on page 657.

Layer Display Options



Which objects display in a 3D view is controlled in the **Layer Display Options** dialog. See “Layer Display Options Dialog” on page 104.

Different view types use different layer sets when they are created. See “Layer Sets” on page 103.

To show framing in a cross section/elevation view, framing must first be built using the **Build Framing** dialog and the appropriate framing layers must be turned on in the Section View layer set. See “Framing” on page 435.

In Floor Plan View

3D cameras are represented in floor plan view by symbols that indicate the camera’s position, field of view and focal point.

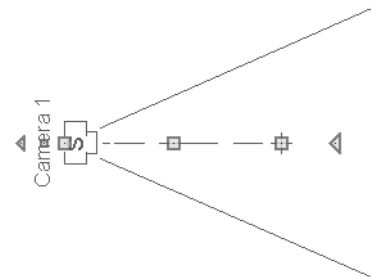

2D camera symbols are located on the “Cameras” layer. See “Layers” on page 101.

By default, active camera symbols display regardless of whether the “Cameras” layer is on or off. If you prefer that their display be turned on or off with this layer, uncheck **Always Display Active Cameras** in the **Camera Defaults** dialog. See “Camera Defaults Dialog” on page 665.

Active camera symbols use the Move color set in the **Preferences** dialog. All other display attributes are derived from the “Cameras” layer. See “Colors Panel” on page 63.

You can also display camera symbols for saved cameras when the “Cameras” layer is turned on. See “Layers” on page 101.





Both saved and unsaved active cameras can have labels indicating the camera number or name. Camera labels are located on the “Cameras, Labels” layer. See “Object Labels” on page 884.

- Camera labels are numbered sequentially in each plan in the order they were created.
- Camera labels always use the Camera Name. Saved cameras’ names can be specified in the **Camera Specification** dialogs. See “Camera Tab” on page 692.

Camera symbols are an on-screen reference: they do not print unless **Print Image** is used and cannot be sent to layout except as an image. They are, however, included in views exported to .dxf.



In Rendered Views

There are a number of factors that contribute to the appearance of rendered 3D views:

- Select **3D> Camera View Options> Toggle Textures**  in a 3D view to turn off the display of material textures. See “About Materials” on page 632. Not available in Glass House, Technical Illustration or Vector Views.
- Select **3D> Lighting> Adjust Lights**  to open the **Adjust Lights** dialog and edit the light sources in the current plan. See “Adjust Lights Dialog” on page 704.
- Select **3D> Camera View Options> Final View**  or **Final View with Shadows**  to regenerate the rendered view based on the final view settings on the Render panel of the **Preferences** dialog. See “Previews vs Final Views” on page 698.

In Vector Views

There are also a number of factors that affect the appearance of 3D Vector Views:

- Select **3D> Toggle Patterns**  in a Vector View to turn on or off the display of the “Patterns, 3D Views” layer, which controls the display of material pattern lines. See “Layers” on page 101.
- Select **Tools> Display Settings> Color On/Off**  to control the display line and fill colors. See “Color On/Off” on page 149.
- The line style, color, and weight of objects in Vector Views can be specified by layer or, for some objects, individually in their specification dialogs. See “Line Style Tab” on page 781.
- The line weight, color, and style of material patterns are set in the **Define Material**

dialog. See “Define Material Dialog” on page 644.

- Line weights display on screen when **Show Line Weights**  is enabled. See “Show Line Weights” on page 845.

3D Backdrops

A backdrop image is like a large billboard image that displays behind the model in 3D views. Backdrop images often show an outdoor scene to add realism and a sense of perspective to 3D views. You can select a backdrop image for a plan from the library in either of two ways:

- In any view, select **3D> 3D View Defaults**  to open the **3D View Defaults** dialog. See “Backdrop Tab” on page 671.
- In a 3D view, open the Library Browser. Browse to and select a Backdrop image, then move your cursor into the view window. Click anywhere in the view to apply the selected backdrop.

Regardless of how it is selected, only one backdrop can be used in a plan at any given time.

You can specify which view types and Rendering Techniques use the selected backdrop in the **3D View Defaults** dialog. By default, Perspective Camera views using the Standard, and Watercolor Rendering Techniques use backdrops while the other techniques and view types do not.

You can also create your own backdrop images and import them into the library. See “Adding New Backdrops” on page 614.

Rendering Techniques



Any 3D view can be assigned a Rendering Technique for a range of different purposes: from detail drawings to artistic presentation views. Select **3D> Rendering Techniques** to access these tools. See “Rendering Techniques” on page 710.

Delete 3D Surface



The individual surface of an object can be temporarily removed from any 3D view by selecting **3D> Delete Surface** and then clicking on a surface. When the pointer is over a surface, that surface will become highlighted.

Surfaces removed in one view are removed in all 3D views, but are not permanently removed from the model. Continue clicking surfaces to remove them, then select another tool when you are finished.

Surfaces in 3D views are composed of multiple triangles. Hold the Alt key while clicking to delete one triangular face at a time rather than all triangles forming a surface. See “Higher Quality Rendering” on page 699.

Select **3D> Delete Surface**  or click the toolbar button to restore the most recently deleted surface. All surfaces can be restored by selecting **Build> Floor> Rebuild Walls/Floors/Ceilings**  or by exiting the 3D view and reopening it.

Rebuild 3D



Select **3D> Rebuild 3D** to regenerate all 3D data associated with the current plan. All open views will remain open.

Remove 3D



Select **3D> Remove 3D** from floor plan view to close all 3D views

associated with the current plan file and remove unsaved 3D data from memory.

Any views saved with the plan are closed but not deleted.

Repositioning Cameras

Once a 3D view is created, there are many ways to manipulate the camera location and the direction of its line of site using the mouse, the keyboard, and the menus.

The Move Camera with Mouse buttons are included on the toolbars in 3D views by default; but, you can add the other tools your toolbars as well as customize their hotkeys. See “Toolbars & Hotkeys” on page 91.

When the keyboard or menu commands are used to move or rotate a camera, the adjustments occur in regular increments. The size of these increments is specified in the **Camera Specification** dialog:

- The **Incremental Move Distance** controls Panning movement and forward and backward Dolly movement.

- The **Incremental Rotate Angle** controls Orbit movement, Tilt movement, and side to side Dolly movement.

See “Camera Specification Dialog” on page 691.

Each time you move the camera, the view is updated. If you are using either the toolbar or keyboard to move the camera, you can hold down the Shift key, suppressing the redraw of the view until the Shift key is released and allowing you to move multiple increments more quickly.







Press Ctrl + Alt + S while in a camera view or overview to spin the view. Press Esc to stop the spinning.

Move Camera with Mouse



An active camera’s position can be edited using the mouse. Select **3D> Move Camera With Mouse** to access the Move Camera with Mouse modes. With the

exception of Mouse Orbit Camera, which is available in Orthographic Overviews, these tools are not available in Orthographic views.

	Hotkey	Description
	Alt + O	Mouse-Orbit Camera lets you move the mouse to rotate the camera around its focal point. The camera's position and direction both change. To continuously rotate the camera around its focal point, click in the 3D view, drag the mouse, and release the mouse button to "throw" the view. Click again in the view to stop it from rotating.
	Alt + P	Mouse-Pan Camera lets you move the mouse to move the camera up, down, left and right. The camera's position changes, but its direction does not.
	Alt + D	Mouse-Dolly Camera lets you move the mouse up and down to move the camera forward and backward. Move the mouse left or right to rotate the camera side to side.
	Alt + T	Mouse-Tilt Camera lets you move the mouse to tilt the camera in any direction while staying in the same location.
		3D Center Camera on Point lets you focus the camera at a particular point in the scene. This also sets the camera center so that future use of Mouse-Orbit Camera rotates around that point. To use the 3D Center tool, activate the tool and then click on any object in the scene.

Move Camera with Arrow Keys

An active camera's position can be changed using the arrow keys on your keyboard.

Select 3D> Move Camera with Arrow Keys to access Move Camera with Arrow Key modes. With the exception of Mouse Orbit Camera, which is available in Orthographic Overviews, these tools are not available in Orthographic views.

These modes use the **Incremental Move Distance** and **Incremental Rotate Angle** set in the active 3D view's **Camera Specification** dialog.

- **Arrow-Orbit Camera** lets you use the arrow keys to rotate the camera around

the current focal point. The camera's position and direction both change.

- **Arrow-Pan Camera** lets you move the camera up, down, right, and left using the arrow keys. The camera's position changes, but its direction does not.
- **Arrow-Dolly Camera** lets you move the camera forward and back using the up and down arrow keys, and rotate side to side using the left and right arrow keys.
- **Arrow-Tilt Camera** lets you use the arrow keys to tilt the camera up, down, or side to side to change the focal point. The







camera's direction changes, but its position does not.

Move Camera Tools



Select **3D> Move Camera** in a 3D view to access these tools. These tools change the active camera's position, but not its direction and are not available in Orthographic views.

These tools use the **Incremental Move Distance** set in the active 3D view's **Camera Specification** dialog.

	Hotkey	Description
	F	Move Camera Forward moves the camera and its focal point forward.
	B	Move Camera Back moves the camera and the focal point back.
	L	Move Camera Left moves the camera and the focal point to the left in a line perpendicular to the line of sight.
	R	Move Camera Right moves the camera and the focal point to the right in a line perpendicular to the line of sight.
	U	Move Camera Up moves the camera and the focal point up.
	D	Move Camera Down moves the camera and the focal point down.







Orbit Camera Tools



Select **3D> Orbit Camera** in a 3D view to access these tools. Orbiting the camera rotates it about the focal point using the **Incremental Rotate Angle** set in

the active view's **Camera Specification** dialog.

These tools are not available in , Back Clipped Cross Section, or Wall Elevation views.



	Hotkey	Description
	I	Move Camera In moves the camera closer to the focal point along the line of sight. The camera cannot move past the focal point using this tool.
	O	Move Camera Out moves the camera away from the focal point along the line of sight.
		Orbit Camera Upward rotates the camera up about the focal point. The camera cannot rotate past a vertical line looking straight down on the focal point.
		Orbit Camera Downward rotates the camera down about the focal point. The camera cannot rotate past a vertical line looking straight up at the focal point.
		Orbit Camera Left rotates the camera to the left about the focal point.
		Orbit Camera Right rotates the camera to the right about the focal point.



Tilt Camera Tools

 Select **3D> Tilt Camera** to access these tools. Tilting keeps the camera in one place and pivots the camera about its vertical or horizontal axis. This movement uses the **Incremental Rotate Angle** set in the active view's **Camera Specification**

dialog and is similar to tilting your head up and down or turning it side-to-side.



These tools are not available in Orthographic views.





	Hotkey	Description
		Tilt Camera Upward tilts the camera up while keeping it in the same location. The camera cannot tilt beyond the vertical position.
		Tilt Camera Downward tilts the camera down while keeping it in the same location. The camera cannot tilt beyond the vertical position.

	Hotkey	Description
		Turn Camera Left turns the camera to the left while staying in the same location.
		Turn Camera Right turns the camera to the right while staying in the same location.

View Direction Tools

 The **View Direction Tools** allow you to view the model from a specific direction in a camera view, overview, or cross section/elevation view. While one of these views is active, select **3D> View Direction** to access these tools.

	Description
	Front View creates a front view of the model.
	Back View creates a back view of the model.

	Description
	Top View creates a top view of the model.
	Bottom View creates a bottom view of the model.
	Left Side View create a left side view of the model.
	Right Side View create a right side view of the model.
	Restore Original View restores the original view position.

Editing 3D Views

In addition to its position and direction, there are other ways to modify a 3D view.

In the Specification Dialog

 You can make adjustments to a camera in the **Camera Specification** dialog. This dialog is particularly helpful for making fine adjustments to the camera's

position, appearance, and other attributes. See “Camera Specification Dialog” on page 691.

 Tile a 3D view and the floor plan view and use the camera movement tools to see how they affect the camera. See “Tiling Views” on page 659.

Using the Edit Tools

A camera symbol or symbols selected in floor plan view can be edited in a variety of ways using the buttons on the edit toolbar. See “The Edit Toolbar” on page 29.

Using the Edit Handles

Return to floor plan view without closing the 3D view. See “Swapping Views” on page 656.

Using the **Select Objects**  tool, select the camera object. When a camera symbol is selected it displays four edit handles.

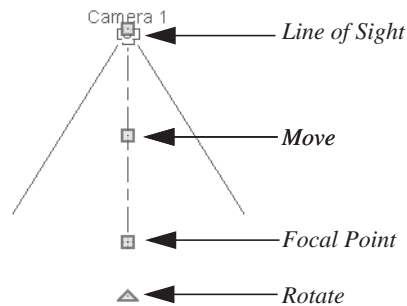

- Drag the **Line of Sight** handle to change the camera angle without moving the focal point.
- Drag the **Move** handle to relocate the camera while maintaining its relative angle.
- Drag the **Focal Point** handle to reposition the focal point and change the line of sight without moving the camera.
- Drag the **Rotate** handle to rotate the camera's line of sight about its center.

The 3D view corresponding to the camera symbol reflects changes made to the symbol in floor plan view.

Multiple camera symbols can be selected; however, their editing options are limited to being moved, rotated, and deleted.

Using the Contextual Menu

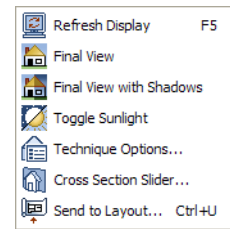

In a 3D view, right-click in an empty space in which the backdrop or background color displays to access the contextual menu. See “Contextual Menus” on page 30.



- In Vector Views, the options are a selection of commonly used commands from the File, Edit, Tools and Window menus.
- In rendered views, the options are a selection of tools and toggles specific to rendered views or override the settings in the **Preferences** dialog. See “Render Panel” on page 86.

Changing a setting in the contextual menu only affects the current view. It does not affect the settings in the **Preferences** dialog.

Up One Floor/Down One Floor

You can move a camera to a different floor. While the camera view is active, select **Tools> Reference Floors> Up One Floor**  or **Down One Floor** .

The position and movement of a camera is affected by its location within the model. When the camera is outside a building, its height is relative to the terrain and follows the terrain as it is moved. When inside a building, the camera height is relative to the floor of the room it is drawn in.

Which floor an active camera is on determines which floor is affected when any floor-specific actions are done. For example, if a camera is on Floor 2 and changes are made to the Floor Default settings while in that view, Floor 2 will be affected.



If the camera is on an upper floor and you move the camera outside of the building, the camera remains at the same height relative to the floor it was created on.

Zooming



The **Zoom Tools** are available in all 3D views. See “Zoom Tools” on page 654.

Selecting **Window > Zoom In** , **Zoom**

Out  or **Fill Window**  does not change the camera’s location or field of view.

Instead, the extents of the view are expanded or cropped.

If you wish, you can instead set the

Zoom  tools to change the Field of View when used in a 3D view. See “Render Panel” on page 86.

Field of View

The **Field of View** refers to a camera’s field of vision. A wider field of view makes the focal point appear further away, as more of the image is included in the same view window.

In floor plan view, the angled lines of a camera symbol indicate its field of view.

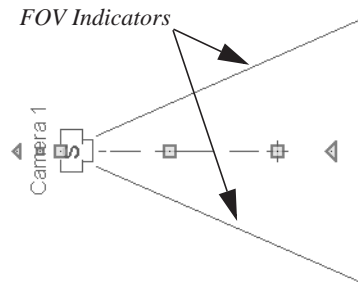

A camera’s field of view can be adjusted in the **Camera Specification** dialog. See “Camera Specification Dialog” on page 691.

The field of view can also be adjusted while in a camera view using the keyboard:

- **W** - Increase camera Field of View.
- **N** - Decrease camera Field of View.

The field of view can also be adjusted with the mouse wheel when **Zoom Using Field of View** is checked in the **Preferences** dialog. See “Render Panel” on page 86.

Cross Section Slider



Select **3D > Camera View Options > Cross Section Slider** when a camera

view or overview is active to open the **Cross Section Slider** dialog.

Note: The Cross Section Slider is not available when the Vector View Rendering Technique is used. See “Rendering Techniques” on page 710.

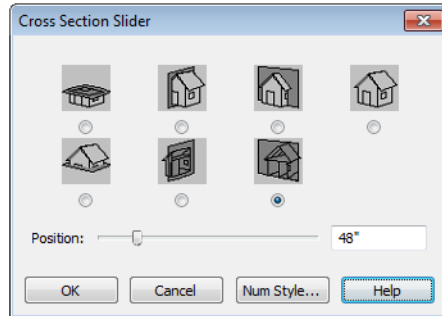

To use the Cross Section Slider

1. Click on the radio button beneath one of the cross section angles to select it.
 - The option at top right turns off the cutting plane, so no cross section is made.
2. Move the **Position** slider to adjust the position of the cutting plane.
3. You can position the cutting plane with accuracy using the text field to the right of the slider.
 - This value is measured from the edge of the model that is cut first by the selected cross section angle.
4. Click **OK** to close the dialog. If the active camera is saved, its Cross Section Slider settings will also be retained. See “Saving 3D Views” on page 690.

Working in 3D

A variety of tools are available in 3D views that allow you to edit your 3D model. You can also use the Dimension, Text, and CAD Tools to add annotation to cross section/ elevation views.



Creating Objects in 3D Views

You can place windows, doors, cabinets, electrical objects, corner trim, and most library objects directly into 3D views. To do this, select the appropriate tool and click in

the 3D view. You can then edit the object's size and placement.

When created in 3D, most objects must be placed against a wall, on a floor platform, or within the Terrain Perimeter.

You can also click and drag to draw some CAD-based objects such as custom countertops, roof planes, terrain features and road, in camera views and overviews views.

The **Build Framing** and **Build Roof** dialogs are also accessible in 3D views, although the manual **Framing Tools**  and **Roof Tools**  are not.

Selecting and Editing Objects in 3D Views

Most objects can be selected and edited in 3D views. Select **Edit> Select Objects**  and click on the surface of an object to select it. Once selected, objects can be edited using their edit handles, buttons on the edit toolbar, and the object's specification dialog. See "Editing Objects" on page 119.

When you select an object, edit handles and a handle surface display. The handle surface is a rectangle around the perimeter of the object that indicates the overall height and width of the selected surface. The edit handles that display depend on the type of object selected. Walls, for example, display two resize edit handles when selected while a slab displays ten handles, allowing you to move, resize and reshape it.

Note: If the wall height of the Exterior Room is adjusted in a 3D view, the default Floor or Ceiling Height of the entire floor is changed. See "Floor and Room Defaults" on page 230.

All moving or resizing is in the plane of the handle surface. You cannot move an object directly towards or away from the camera, for example, because that surface plane cannot be seen in the view.

By default, object movement is restricted to one inch or 10 mm increments, but this restriction can be set to custom increments in the **Plan Defaults** dialog and toggled off and on using the **Grid Snaps**  button. See "Grid Snaps" on page 112.

Unrestricted positioning can also be enabled by holding down the Ctrl key while moving or resizing an object. See "Unrestricted Movement" on page 153.

When **Fixture/Furniture Resize Enable** is unchecked in the **Plan Defaults** dialog, only a single handle displays for furniture and stand-alone fixtures and appliances. In this case, the object can only be moved. See "General Plan Defaults Dialog" on page 58.

Temporary dimension lines display when many objects are selected to help you resize the object and determine its height. These are sometimes easier to see when the color is toggled off. See "Display Temporary Dimensions" on page 731.

Because cross section/elevation views are orthogonal and display objects at their actual dimensions, they are sometimes more suitable for editing objects than camera views or overviews. See "Cross Section/Elevation Views" on page 675.

When several 3D views are open, changes made in the plan automatically rebuild the model in all views. Because of this, it is typically faster to make changes to your plan with as few windows open as possible.

Editing Materials in 3D Views



Select **3D> Materials> Adjust Material Definition**, then click on a surface in the 3D view to open the **Define Material** dialog for that material. See “Adjust Material Definition” on page 637.



Select **3D> Material Painter** to apply materials to surfaces in the view using the Material Painter Tools. See “The Material Painter” on page 632.



Select **3D> Material Painter> Material Eyedropper** to apply the material on a surface in the view to other surfaces in the view. See “Material Eyedropper” on page 634.

Rebuild 3D



As changes are made to your plan, a 3D view automatically updates to reflect any changes visible in the view. If you find that a view is not updating as expected, select **3D> Rebuild 3D** to rebuild the entire 3D model.

Annotating 3D Views

The Dimension Tools, Text Tools, and CAD Tools are available in cross section/elevation views, allowing you to add technical information, call attention to details, and other tasks in these views. See “Detailing

Cross Section/Elevation Views” on page 677.

Cross Section Lines

Cross Section Lines are created in cross section views to represent any objects split by the cross section line of the camera. They are placed on the “Cross Section Lines” layer, which is locked by default, and they get deleted and replaced whenever the view is redrawn.

When a dimension is drawn to locate an object split by a camera’s section line, it actually locates Cross Section Lines. So that dimensions can be retained when Cross Section Lines are regenerated, a **Point**

Marker  is automatically created where a dimension meets a Cross Section Line and the dimension locates it instead of the Cross Section Line. See “Point Markers and Dimensions” on page 763.

Cross Section Lines will print when their layer is turned on; however, they are not included when the view is sent to layout. The Point Markers created when dimensions locate Cross Section Lines, however, will both print and display in views sent to layout. See “Layout” on page 863.

The “Cross Section Lines” layer can be unlocked, allowing Cross Section Lines to be selected and edited. Additional CAD objects can also be placed on this layer when it is unlocked, as well; however, when the view is redrawn, all CAD objects on this layer will be deleted and replaced with a fresh set of Cross Section Lines.

Saving & Printing 3D Views

3D camera views, overviews and cross section/elevation views can be saved with the plan in which they are created, exported and saved as image files, as well as sent to layout and printed.

Saving 3D Views





Select **3D> Save Active Camera** to save the current camera in the plan. You can also save a camera view by checking the **Saved** box in the **Camera Specification** dialog. See “Camera Specification Dialog” on page 691.

Saved cameras can be closed and re-opened for later use, and retain their Cross Section Slider and Rendering Technique settings. See “Cross Section Slider” on page 686 and “Rendering Techniques” on page 710.

In addition, if CAD or Text objects are drawn in a cross section/elevation view, you will be prompted to save the view when you close it. Any CAD or Text objects added to a cross section/elevation view are saved with the view as part of the plan file.

Activating Saved Views

There are three ways to open a saved 3D view:

- Select the camera symbol in floor plan view and click the **Open View**  edit button.
- Double-click the camera symbol using the **Select Objects**  tool.
- Right-click on it and select **Open View** from the contextual menu.

Unsaved cameras that are open in another view window can also be activated using the

Open View  edit button.

If you open a saved camera view and then modify its location or direction using any of the tools available in that view, the program will confirm whether you want to re-save the camera using these new settings when you close it. See “Repositioning Cameras” on page 680.

Exporting 3D Views



All 3D views can be exported and saved as .bmp, .jpg, .png, or .tif files. Select **File> Export> Picture** to save the current screen image as an image file. See “To export a picture” on page 811.

In addition, Vector Views can be exported and saved as .emf files. See “Metafiles” on page 814.

Once saved, a picture can be opened and converted into many other formats using a graphics program. Picture files can be sent to layout or used in word processing, desktop publishing, and web development programs to create advertisements, brochures, etc.

When a picture is exported, it is assigned the same size as it displays on screen. You can change the size of the view window to create a smaller or bigger picture.

Plan Backup



When transferring a plan to another computer or to another user, it is helpful to include all the Images, Textures,

and Backdrops used in the plan so that rendered views are complete. The **Backup Entire Plan** tool allows you to do so. See “Backup Entire Plan” on page 52.

Printing 3D Views



Since all 3D views other than Vector Views are created using pixels instead of lines, **File> Print> Print Image** must be used when printing. **Print Image** is a special Home Designer Pro function that prints the screen in picture format. The entire view prints, including images such as plants and textures.

The quality of your print image is affected by your current window size and screen resolution. To maximize the quality of your printed image, generate it in full screen size and use the maximum screen resolution.

3D views can also be sent to layout and then printed as part of your construction documents.



Select **File> Send to Layout** to send the current view to layout. See “Sending Views to Layout” on page 866.



Select a saved, inactive camera symbol in floor plan view and click the **Send Camera's View to Layout** edit button to send the view to layout.

Camera Specification Dialog



The **Camera Specification** dialog can be accessed in floor plan view by selecting a single camera symbol and clicking the **Open Object** edit button. See “In Floor Plan View” on page 677.

This dialog can also be accessed while a camera view or overview is active by selecting **3D> Edit Active Camera** .

The selected view's specific type is indicated in the dialog's title bar: the specification dialog for a **Full Camera** , for example, is named **Full Camera Specification**.

This dialog can only be opened for one camera at a time. If more than one camera symbol is selected, **Open Object**  will not be available.

Camera Tab

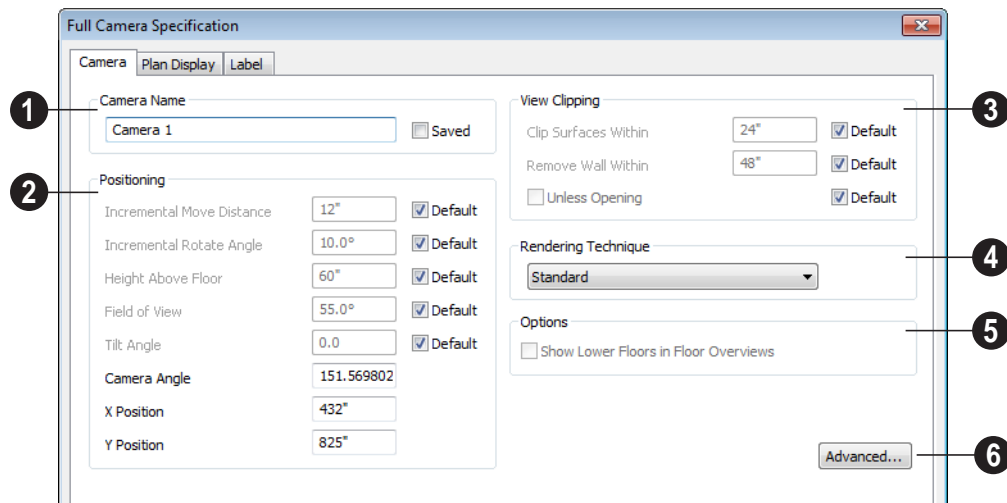

Some settings only affect some types of views. Depending on the type of camera view selected, not all the settings may be editable.

To change a setting, first uncheck **Default**, then type a new value in the text field.

- 1 Specify the **Camera Name** that displays with the camera symbol in floor plan view.
 - Check **Saved** to save this view with the plan. As soon as you type anything in the text field, this box becomes checked. If you click OK while this box is checked, it will become checked permanently.
- 2 The **Positioning** settings determine the position and orientation of the camera. See “Repositioning Cameras” on page 680.
 - The **Incremental Move Distance** controls how far the camera moves each time you Pan in any direction or Dolly forwards or backward. For interior views a

small number is good, but for exterior you may want a larger increment.

- The **Incremental Rotate Angle** defines how many degrees the camera rotates each time you Tilt, Orbit, or Dolly side to side. A setting of 90° would make one full rotation in four moves.
- The **Height Above Floor** defines the height that the camera is above the floor level for the current floor.
- The **Field of View** defines the camera’s field of vision in angular degrees. See “Field of View” on page 686.



You can increase a camera’s Field of View when the view is active by pressing the W key, or decrease the Field of View by pressing the N key.

- The **Tilt Angle** determines the angle the camera is tilted. The camera maintains its focal point and position in floor plan

view, but if the camera is tilted, the focal point is above or below the current camera height.

- Specify the selected camera's **Camera Angle**. This is an absolute value: an angle of 0° points the camera toward the left in floor plan view.
 - Specify the **X Position** and **Y Position** for the selected camera. These are absolute coordinates. Specifying zero for both places the camera at the plan's origin point (0,0).
 - Check **Default** for any value to use the default setting.
- ③ Settings in the **Wall and Surfaces** section determine the extent of the camera view.
- **Clip Surfaces Within** - Objects located within this distance from the camera do not display in the view.
 - **Remove Wall Within** - Remove the view of walls within this distance of the camera.

Both of these **Within** distances are measured as a radius from the camera position.

- Check **Unless Opening** to display a wall that is inside the **Remove Wall Within** range if the camera is pointing through an opening such as a door or window.
 - Check **Default** for any value to use the default setting.
- ④ Select the **Rendering Technique** used by the selected camera from the drop-down list. See "Rendering Techniques" on page 710.
- ⑤ Uncheck **Show Lower Floors** to show only the current floor in the selected Floor Overview. When checked, the current floor plus any floors beneath it are included in the view. Only available for Floor Overviews. See "Doll House View" on page 675.
- ⑥ Click the **Advanced** button to open the **Advanced Camera Options** dialog and specify how hidden lines are handled in Vector Views when OpenGL is not used. See "Advanced Camera Options Dialog" on page 668.

Plan Display Tab

The settings on the Plan Display tab control the appearance of the selected camera in

floor plan view. See "In Floor Plan View" on page 677.

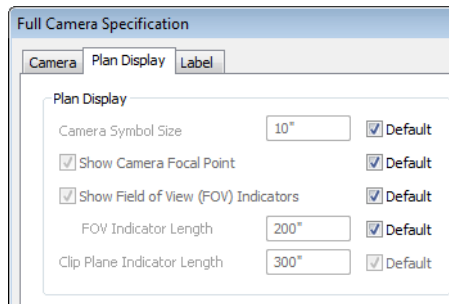

The **Standard Options** settings allow you to specify the appearance of the selected camera's standard symbol. Uncheck **Default** beside any of these options to modify it. See "Dynamic Defaults" on page 57.

- The **Camera Symbol Size** is measured in plan inches (mm).
- Check **Show Camera Focal Point** to display the camera's focal point in floor plan view. When unchecked, the view's line of sight and focal point are hidden until the camera is selected; cross section/elevation camera clip plane indicators are suppressed in the same manner when this is unchecked.
- Check **Show Field of View Indicators** to display the camera's field of view indicators in floor plan view. You can also change the **FOV Indicator Length**, which is measured in plan inches (mm).

- Specify the **Clip Plane Indicator Length** in plan inches (mm). This is the length of the clip plane indicator line(s) for cross section/elevation views only and is available when Display as Callout is checked. See "To create a Cross Section/Elevation view" on page 676.

Label Tab

In the **Camera Specification** dialogs, the settings on the Label tab are limited to Suppress Label checkbox and Position and Orientation settings.

Camera labels always use the **Camera Name** specified on the Camera tab. When callouts are used, the **Callout Label** and **Text Below Line** are specified on the Plan Display tab.

For information about this tab, see "Label Tab" on page 885.

Cross Section/Elevation Camera Specification



The **Cross Section/Elevation Camera** and **Wall Elevation Camera Specification** dialogs can be accessed in floor plan view by selecting a single cross section/elevation camera symbol and

clicking the **Open Object** edit button. See "In Floor Plan View" on page 677.

These dialogs can also be accessed while a cross section/elevation camera view is active by selecting **3D> Edit Active Camera** .

Camera Tab

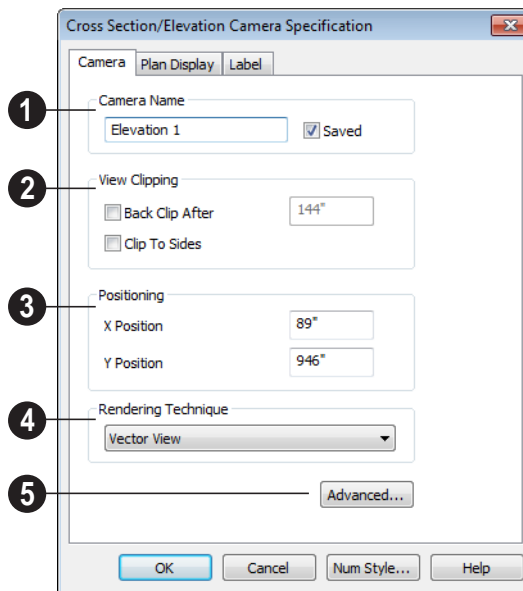

- 1 The **Camera Name** displays in floor plan view.
 - Check **Saved** to save this view with the plan. As soon as you type anything in the text field, this box becomes checked. If you click OK while this box is checked, it will become checked permanently.
- 2 The **View Clipping** settings control the extents of the camera view.
 - **Back Clip After** - Enter the distance in inches (mm) from camera to backclip plane. If zero, no back clipping occurs.
 - Check **Clip To Sides** to limit the selected camera view's side-to-side extents to the length of its Clip Plane Indicator line(s) in floor plan view. When unchecked, the full width of the model is included in the view.

The **Clip Plane Indicator Length** can be specified on the Plan Display tab when callouts are not used, or using the camera's edit handles in floor plan view. See "Editing 3D Views" on page 684.

- 3 Settings in the **Positioning** section determine the location of the camera in floor plan view.
 - Specify the **X Position** of the camera in absolute coordinates.
 - Specify the **Y Position** of the camera in absolute coordinates.
- 4 Select the **Rendering Technique** used by the selected camera from the drop-down list. See "Rendering Techniques" on page 710.
- 5 Click the **Advanced** button to open the **Advanced Camera Options** dialog and

specify how hidden lines are handled in Vector Views when OpenGL is not used. See “Advanced Camera Options Dialog” on page 668.

Plan Display Tab

The settings on this tab are also found in the **Camera Specification** dialog. See “Plan Display Tab” on page 693.

Label Tab

In the **Cross Section/Elevation Camera Specification** dialog, the settings on the

Label tab are limited to **Suppress Label** checkbox and **Position** and **Orientation** settings.

Camera labels always use the **Camera Name** specified on the Camera tab. When callouts are used, the **Callout Label** and **Text Below Line** are specified on the Plan Display tab.

For information about this tab, see “Label Tab” on page 885.

3D Rendering

There are a variety of tools available to create 3D views of a model: simply click a button to create an overview, or click and drag to create a camera or cross section/elevation view. See “3D Views” on page 663.

To improve the quality of the rendering and create a custom look, you can adjust lighting, edit the materials used in the plan, choose from several rendering techniques and fine-tune 3D view quality settings. From most 3D views, you can create Final views of even higher quality.

Chapter Contents

- Rendering Tips
- Lighting
- Displaying Lights
- Light Types
- Default Sun Light Specification Dialog
- Sun Angle Specification Dialog
- Rendering Techniques
- Rendering Technique Options
- Speeding up 3D View Generation

Rendering Tips

There are a variety of factors which affect the appearance and quality of rendered 3D views. You can use these tools and settings to achieve renderings that meet your needs.

Lighting

Lighting is extremely important in most 3D renderings. Lighting controls the visibility of objects in a view, affects the appearance of

surfaces, and influences the appearances of colors and textures on those surfaces. Even small changes to light intensity, direction and color can have a large impact on image quality. See “Lighting” on page 699.

Material Textures

Textures are graphic files that represent contoured surfaces of objects such as carpet,

bricks, tile, and wood in rendered views. Textures are assigned to materials which in turn are assigned to objects. See “Patterns and Textures” on page 632.

The display of materials in rendered views is controlled by settings on the Texture and Properties tabs of the **Define Material** dialog. See “Define Material Dialog” on page 644.

For realistic rendered views, it is important to adjust texture properties correctly. Textures can be mapped to objects for correct placement. See “Mapping Patterns and Textures” on page 638.

Brightness, shininess and transparency control how light sources affect the display of surfaces in rendered views. See “Lighting” on page 699.

If no texture is selected for a material or if the display of textures is turned off, affected surfaces are a solid color instead.

Images

Images are very important for the appearance of rendered views. Images are picture files that represent individual objects such as trees, flowers, cars, and people. Images are represented in floor plan view by 2D symbol and are visible in Vector views. See “Placing Images” on page 806.

Backdrops

Backdrops are images that display in the background of 3D views. Only one backdrop can be used at a time. If a backdrop is not applied, Home Designer Pro applies a background color.

Backdrops and background colors are selected in the **3D View Defaults** dialog. See “Backdrop Tab” on page 671.

You can also add a backdrop directly into a 3D view from the Library Browser. To do this, select a backdrop in the the Library Browser and move your pointer into the view window. The pointer will display the

Backdrop  icon. Click once in the view to apply the selected backdrop to this and all other 3D views using backdrops in the current plan.

Spherical Panoramic Backdrops are a special type of backdrop that wraps around the model in 3D views as though it were applied to a sphere surrounding it.

It takes a special camera or an image processing program to generate spherical panoramic backdrops.



Previews vs Final Views

With the exception of Vector Views, 3D views are generated using the Preview settings in the **Preferences** dialog. Rather than produce the best quality possible, the installed settings for Previews generate 3D views quickly but with reasonable quality, and are best when working on the model in 3D. See “Render Panel” on page 86.

Final Views produce much higher quality images that are more suitable for printing or saving as graphics files. Final Views often take significantly longer to generate than Previews, so the 3D view reverts back to the Preview settings as soon as anything is changed within the view.

When you have finished making adjustments in the 3D view, select **3D> Camera View**

Options > Final View  or **Final View with Shadows** .

Final View  is not available in Vector Views. **Final View with Shadows**  is not available in Vector View, Glass House, or Line Drawing views. See “Rendering Techniques” on page 710.

Higher Quality Rendering

The settings on the Render panel of the **Preferences** dialog allow you to adjust rendering quality and speed so that you can strike a balance that best suits your needs. For high quality Final Views, consider experimenting with these settings:

- **Soft Shadows** displays shadows with soft edges instead of hard edges. This feature is only used when Show Shadows is used and can slow renderings considerably.

- **Triangle Size** - When you use triangles, the program divides surfaces in most 3D views into triangles which are used to illuminate the surfaces properly. Generally speaking the smaller the **Triangle Size**, the slower the rendering, but the higher-quality result you can achieve. Triangles are not used in the Standard and Technical Illustration Rendering Techniques. See “Rendering Techniques” on page 710.
- **Use Transparency** - Necessary to display transparent or semi-transparent surfaces such as the glass in windows in rendered views.
- **Software Edge Smoothing** - A higher degree of surface edge smoothing can significantly improve the quality of a 3D view.

Lighting

In rendered views, lighting is calculated on a room-by-room basis; only the light sources in the room containing the camera are used.

When the camera is outside a building, the program normally uses sunlight for lighting calculations and turns off all other light sources. You can turn the sunlight off and use all the other exterior lights to simulate night time views.

The maximum number of light sources that can be turned on in a view at the same time is determined by your video card. If your video card’s maximum number of lights is eight, the program only uses the eight light sources closest to the camera’s position. You can



manually turn on and off individual lights in order to get the desired lighting effects. See “Displaying Lights” on page 703.

Each individual light source has a set of Rendering properties, such as intensity and color, that can be defined. See “Light Data Tab” on page 706.

Ambient Light

Ambient light is used to simulate the way light “bounces” around a scene and approximates this by ensuring that all objects are at least as bright as the specified ambient value, which is set in the **3DView Defaults** dialog. See “Options Tab” on page 669.

Ambient light is in addition to other light sources in a room or scene. Too much ambient light can give a rendered view a flat look.

- **Interior Ambient** controls the ambient light in interior rendered views of the model.
- **Daytime Ambient** controls the ambient light in exterior rendered views of the model when **Toggle Sunlight**  is on. See “Sun Angles” on page 701.
- **Nighttime Ambient** controls the ambient light in exterior rendered views of the model when **Toggle Sunlight**  is off.

In addition to the ambient lighting specified in the **3D View Defaults** dialog, there are four ways to create light sources for rendered views:

- Default Lights
- Light Fixtures
- Added Lights
- Sunlight

Default Lights

If you create an interior rendered view of a room and no lights have been placed there, the program creates a Default Light source within that room. The Default interior light acts like a central point light source.

By default, a parallel light source is also added to interior views which shines straight up to add extra illumination to ceilings. The intensity of this light is adjusted with the Interior Ambient intensity, and it can be turned off entirely in the **3D View Defaults** dialog.

The Default Light cannot be adjusted in any way. If you want to control the light in an interior rendered view, you must add a light to the room that you are rendering by placing a lighting fixture or by adding a light source using **3D> Lighting> Add Lights** .

Light Fixtures

An electric symbol that represents a **Light Fixture** can have one or more light sources associated with it. Properties for each light source such as light type, color and intensity can be modified in the fixture’s **Electrical Service Specification**. See “Electrical Service Specification Dialog” on page 492.

If the light source is a Point or Spot Light, you can also adjust the Offsets to specify the light source’s position relative to the fixture. By using **Show Position in Camera View**, you can tell where in the scene your light is located.

Lighting looks most realistic if it is offset from a surface.

Added Lights

 In floor plan view, select **3D> Lighting> Add Lights** to quickly add a light source to a plan. Added Lights and their labels are placed on the “Light Sources” and “Light Sources, Labels” layers.

Added lights only act as light sources in plan files that have at least one room defined. They display 2D symbols in floor plan view but do not display as objects in 3D views.

While Added Lights do not display as objects in 3D, you can specify that an Added Light’s position be represented by a cross hairs in

rendered views that use lighting. See “Light Data Tab” on page 493.

Added lights can be placed into objects that normally do not generate light, such as a TV.

There are three types of added light sources:

- Parallel Light sources
- Point Light sources
- Spot Light sources

See “Light Types” on page 705.

Sun Angles



Sun Angle arrows display in floor plan view and indicate the angle of the sun at a specific time and location on the Earth at sea level. Sun Angles control the position of the sun in 3D views and can also produce sun shadows in floor plan view.

Note: Sun Angle calculations do not adjust for elevation. They are based on formulas published by the United States Naval Observatory and have limited accuracy as documented by the USNO.

Multiple Sun Angles can be created in floor plan view, each with different specifications. For best results, only turn one Sun Angle on at a time. See “Sun Angle Specification Dialog” on page 708.

Sun Angles can display their date and time in floor plan view. Both Sun Angles and their

shadows are on the “Sun Angles & Shadows” layer.

Sun Angles are also Parallel Lights. When an exterior 3D view is rendered, the program looks for any Sun Angles that are turned on. If it finds none, the Default Sun is used.

To accurately define the Sun’s location relative to the model, use a **North**

Pointer . See “North Pointer” on page 778.

To create a Sun Angle

1. Make the first floor or foundation level the current floor. Sun Angles can only be created on these floor levels.
2. In floor plan view, select **CAD> Lines> Sun Angle** and click in the drawing area where the Sun Angle arrow should display.
3. In the **Sun Angle Specification** dialog, specify the Sun Angle’s Earth Data and other information. See “Sun Angle Specification Dialog” on page 708.
4. After it is created, a Sun Angle can be moved to a different location in floor plan view. Shadows are not affected.

A Sun Angle’s position is specified by Latitude and Longitude. The following table lists a sample of latitude and longitude values for some cities:

City	Latitude	Longitude
Atlanta, GA	33.44°N	84.23°W
Chicago, IL	41.53°N	87.38°W
Denver, CO	33.44°N	104.59°W
Mexico City	19.24°N	99.09°W
New York, NY	40.43°N	74.01°W
Perth, AU	31.56°S	115.50°E
San Diego, CA	32.42°N	117.09°W
San Francisco, CA	37.46°N	122.25°W
Seattle, WA	47.36°N	122.19°W
Sydney, AU	33.52°S	151.13°E

Default Sun Light

If you create an exterior rendered view and no Sun Angle exists, the program creates a **Default Sun**. The Default Sun acts like a parallel light source but its location is not based on any real world locations.

The Default Sun can be opened for specification in a rendered view by selecting **3D> Lighting> Adjust Lights** . See “Default Sun Light Specification Dialog” on page 707.

If you place a **Sun Angle**  in floor plan view, the Default Sun is no longer used as a light source in exterior rendered views unless the Sun Angle’s light is turned off.

Sun Shadows

Sun Angles  allow the shadow cast by a building at any time of the year to be displayed in floor plan and rendered views.

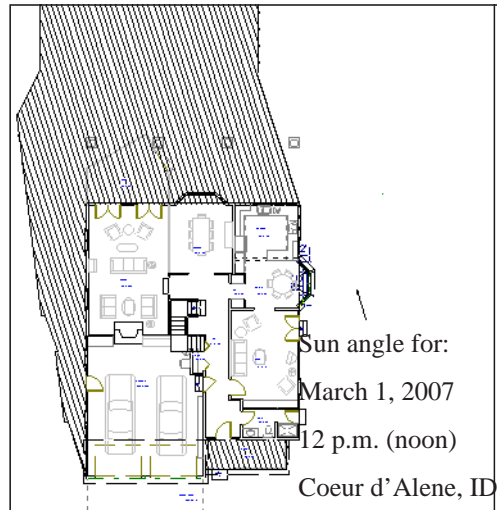

To display shadows created by a Sun Angle

1. On the Render panel of the **Preferences** dialog, check **Show Shadows** for Pre-view and/or Final View. See “Render Panel” on page 86.
2. Select a Sun Angle and click the **Open Object**  edit button.
3. On the Render Data tab of the **Sun Angle Specification** dialog, make sure that **Casts Shadows** is checked.
4. To display the shadow in floor plan view, click the **Make Shadow** button on the Earth Data tab.

Multiple Sun Angles can be placed in the same plan to allow the simultaneous display of shadows cast at different times in floor plan view.

 Specify different line colors and/or styles for shadows cast by multiple Sun Angles in the Sun Angle Specification dialog. See “Earth Data Tab” on page 708.

If no Terrain Perimeter has been created, shadows fall on an imaginary plane at height zero, the default height for the first floor. If a Terrain Perimeter exists, shadows are modified to indicate where the real shadow would fall on the actual terrain.

There are several ways to delete the shadow created by a Sun Angle.

- In floor plan view, select and delete the defining polyline.

- In floor plan view, select and delete the Sun Angle arrow.
- In the **Sun Angle Specification** dialog, click the **Delete Shadow** button. See “Earth Data Tab” on page 708.
- In the **Sun Angle Specification** dialog, click the **Make Shadow** button to delete the existing shadow and create a new one.

Displaying Lights



The display of light fixtures and Added Lights in floor plan and 3D views is controlled in the **Layer Display Options** dialog. See “Layer Display Options Dialog” on page 104.

In addition, they can serve as sources of light in rendered 3D views. They can be turned on and off, as well as set to cast shadows.

In Floor Plan View

Light fixtures are placed on the “Electrical” layer, and Added Lights, on the “Light Sources” layer. See “Displaying Objects” on page 102.

In floor plan view, both light fixtures and Added Lights can display labels when the “Electrical, Labels” and/or “Light Sources, Labels” layers are turned on. See “Object Labels” on page 884.

An Added Light’s label in floor plan view indicates which of these attributes the light has:

- R - Used in Standard rendered views.
- S - Casts shadows.

- No letters - Light is not turned on.





A Point Light that casts shadows in Standard rendered views

In 3D Views

Both light fixtures and Added Lights can serve as sources of light in rendered views.

To turn a light on or off

There are several ways to turn a light fixture or Added Light on or off:

- Select one or more fixtures or Added Lights and click the **Turn Light(s) Off in 3D**  or **Turn Light(s) On in 3D**  edit button.
- Uncheck **On** in the object’s specification dialog. See “Light Data Tab” on page 493.

- Clear the **On/Off** checkbox in the **Adjust Lights** dialog.

Added Lights are not associated with a 3D fixture, but you can specify that an Added

Light's location be represented in rendered 3D views using a cross hairs. See "Light Data Tab" on page 493.

Adjust Lights Dialog



Light sources in the current plan can be accessed and edited using the **Adjust Lights** dialog. Select **3D> Lighting>**

Adjust Lights to open this dialog in floor plan or any 3D view.

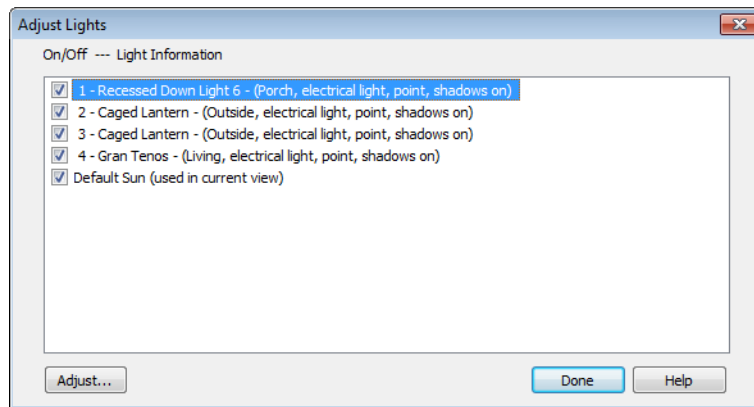

The names of all lights, as displayed in their labels, in the current plan are listed here. Additional information about the light follows in parentheses. If the dialog is opened while a 3D view is active, the Default Sun Light will be included in the list; however, interior default lights are not listed and cannot be altered. See "Default Sun Light" on page 702.

Check the box beside a light's name to turn it on or uncheck the box to turn it off.

To adjust the properties a light in the list, select it and click the **Adjust** button.

Multiple lights can be selected by holding down the Shift key. Make changes to the light in its specification dialog and click **OK**. For more information, see "Default Sun Light Specification Dialog" on page 707, "Light Specification Dialog" on page 706 or "Electrical Service Specification Dialog" on page 492.

Select another light to adjust or click **Done**.

If you are in a 3D view that displays lighting, the view will regenerate based on the new light settings.

Light Types

There are three types of light source, each of which generates light in a different way and allows you to create a variety of lighting effects:

- Parallel Light sources
- Point Light sources
- Spot Light sources

Both the properties and the light type of an Added Light can be modified in the **Light Specification** dialog. See “Light Specification Dialog” on page 706.

Parallel, Point and Spot lights can also be added to an electrical light fixture in the **Electrical Service Specification** dialog. See “Light Data Tab” on page 493.

Parallel Lights



A **Parallel Light** has a direction but no position. The light appears to illuminate all objects with equal intensity, as if it were at an infinite distance from the object. A Parallel Light source is commonly used to simulate distant light sources, such as the sun and works best when placed on the exterior of a structure.

To add a Parallel Light

1. In floor plan view, select **3D> Lighting> Add Lights** .
2. Click and drag in floor plan view two or more plan feet (600 mm) in any direction.

3. When you have dragged a sufficient distance, the light preview will change to a parallel light icon.
4. When you release the mouse, a parallel light pointing in the direction that you dragged is created.

Point Lights



Like a bare light bulb, a **Point Light** radiates light equally in all directions from its origin. Point lights are a more realistic representation of non-directional electric lighting and should be used when realism is the deciding concern.

If no user defined light exists, Home Designer Pro creates a Point Light source to represent a light within a room. Any light source, except a Sun Angle, can be changed into a Point Light.

To create a Point Light source

1. In floor plan view, select **3D> Lighting> Add Lights** .
2. Click in floor plan view. Do not drag the pointer when you click the screen, or you will create a spot or parallel light.

Spot Lights



A **Spot Light** focuses the light in a specified direction. The location, tilt angle, direction and intensity of a Spot Light can be defined. You can also change a Spot Light’s direction by rotating the light in floor plan view.

To create a Spot Light source

1. In floor plan view, select **3D> Lighting> Add Lights** .
2. Click and drag in floor plan view no more than two plan feet (600 mm) in any direction.

3. As you drag, the light preview will look like a Spot Light icon. If you drag too far, it will change to a Parallel Light icon.
4. When you release the mouse, a Spot Light pointing in the direction that you dragged is created.

Light Specification Dialog



Select one or more parallel, point or spot lights and click the **Open Object** edit button to open the **Light Specification** dialog.

You can also select **3D> Lighting> Adjust**

Lights  to access a list of the light sources present in the current plan and open the specification dialog for any of them. See “Displaying Lights” on page 703.

In addition, you can right-click on a light fixture in an unlocked library (see “Adding Library Content” on page 613) or click on it and select **Library> Edit Light Data** to open a version of the **Light Specification** dialog that is similar to the **Electrical Service Specification** dialog. See “Light Data Tab” on page 493.

Location Tab

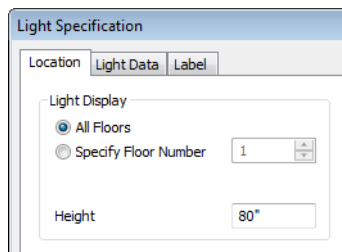

Light Display - Specify where the selected Added Light displays in floor plan and 3D views.

- Select **All Floors** to display the selected light on all floors in floor plan view.
- Select **Specify Floor Number** to display the light on one floor only, then choose a floor number from the drop-down list.

Note: The floor or floors that an Added Light displays on in floor plan view is totally independent of where it displays in 3D.

- Specify the selected light’s **Height**. The Height of an Added Light is always relative to Floor 1. If you want an Added Light to illuminate a room on Floor 2, use a Height value that includes the total height of the first floor. A value of 0 equals the floor elevation of Floor 1. See “Multiple Floors” on page 315.

Light Data Tab

The settings on this tab are also found on the same tab of the **Electrical Service Specification** dialog. See “Light Data Tab” on page 493.

Depending on the type of light selected, the options available here may vary.

Label Tab

Labels for Added Lights display in floor plan view when the “Light Sources, Labels” layer

is turned on and use the Text Style assigned to that layer. See “Text Styles” on page 765.

For information about the settings on this tab, see “Label Tab” on page 885.

Default Sun Light Specification Dialog

The **Default Sun Light Specification** dialog allows you to control the intensity, direction and color of the Default Sun light source.

While in a 3D view, select **3D> Lighting>**

Adjust Lights . See “Adjust Lights Dialog” on page 704.

If there are no light fixtures or added lights in the plan, this dialog will open as soon as **Adjust Lights** is selected.

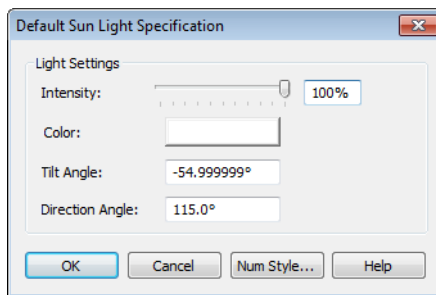

- Use the **Intensity** slider bar or text field to control how bright the default sun light appears in rendered views.

An intensity of 0% is the same as turning the sun light off. An intensity of 100% is the maximum brightness allowed.

- Click the **Color** bar to define the color of the light being modeled. Colored sun light may be used to achieve special lighting effects, but may alter the appearance of your material colors and textures.
- Specify the **Tilt Angle**, which is the angle of the sun light with respect to the horizon. A value of 90° means that the light points straight up, while a value of -90° means that the light points straight down. 0° is parallel to the horizon.
- Specify the **Direction Angle**, which is the direction that the sun light points toward. Zero degrees is measured horizontally on screen, pointing to the right. Positive values rotate in a counter-clockwise direction from there, while negative values rotate clockwise.
- Specify the **Num Style** button to specify the format used to enter angle values. See “Number Style/Angle Style Dialog” on page 89.

The Default Sun light color is pure white, which has the least effect on the material colors and textures.

Sun Angle Specification Dialog



Select **CAD> Lines> Sun Angle**, then click anywhere in floor plan view to open the **Sun Angle Specification** dialog and create a new sun angle. See “Sun Angles” on page 701.

You can also open the **Sun Angle Specification** dialog for an existing sun angle by selecting it and clicking the **Open Object**  edit button.

Earth Data Tab

The settings on the Earth Data tab let you establish exactly where on the planet your plan’s building site is located, and exactly when the sun’s light should be calculated.

This information allows the program to generate sunlight and sun shadows with accuracy.

- 1 Specify the **Latitude**, which is measured north or south of the equator.
- 2 Specify the **Longitude**, which is measured east or west of the Greenwich meridian.
- 3 Specify a **Date** for each Sun Angle you create.
- 4 Specify a **Time** for each Sun Angle you create.
- 5 Select a month from the first drop-down list, a day from the second, and a year from the third.
- 6 Specify an hour from the first drop-down list; minutes in 15 minute increments can be selected from the second list.
- 7 Select a time zone from the drop-down list.
- 8 Check the **Always Update** checkbox.
- 9 Check the **Show Date on Sun Angle** checkbox.
- 10 Check the **Auto Rebuild Terrain** checkbox.
- 11 Specify the **Length of Plan Symbol**.
- 12 Click the **Make Shadow** or **Delete Shadow** button.

- If you want the Sun Angle to observe **Daylight Savings Time**, check this box.

- 5 Specify the **Time Zone** that the building site is located in.

The previous values default to the settings in the **Preferences** dialog. See “Sun Angle Panel” on page 75.

- 6 **Solar Angles** - The **Altitude** and **Direction** of the sun based on the information provided above display here for reference.

- The **Altitude** is the angle of the sun above the horizontal plane, in degrees.
- The **Direction** is the angle between true North and the sun's direction. This is the angle the Sun Angle arrow points in floor plan view. See “North Pointer” on page 778.

- 7 Check **Always Update** to have the program update the selected Sun Angle's shadow whenever any of the defining information is changed.

- When checked, the program may be slower when changes are made in this dialog.
- If this is not checked, click the **Make Shadow** button to generate a new shadow based on the new information.

- 8 Check **Show Date on Sun Angle** to have the date and time display on the Sun Angle arrow in floor plan view. This

label uses the Text Style assigned to the “Sun Angle & Shadows” layer. See “Text Styles” on page 765.

- 9 Check **Auto Rebuild Terrain** to rebuild the terrain automatically whenever you create a sun shadow. See “Building the Terrain” on page 552.

If **Auto Rebuild Terrain** is unchecked and you regenerate sun shadows, the program will prompt you to rebuild the terrain.

When you use the **Build Terrain** command in floor plan view, all sun shadows in the plan are automatically updated.

- 10 Specify the **Length of Plan Symbol**, which is the length of the Sun Angle arrow in floor plan view.

- 11 Click the **Make Shadow** button to create or regenerate the sun shadow in floor plan view. Sun shadows are polylines filled with a hatch pattern. Their shapes and sizes are based on the Sun Angle data specified in this dialog.

No sun shadow generates if the sun is not above the horizon or if the sun is so low on the horizon that the shadow would be extremely long.

Note that the **Make Shadow** option does not affect 3D views. To view sun shadows in a

3D view, use **Final View with Shadows** . See “Previews vs Final Views” on page 698.

- 12 Click the **Delete Shadow** button to remove the sun shadow from floor plan view.

Lighting Data Tab

A Sun Angle can be used as a light source in rendered views. The settings on the Lighting Data tab control attributes of the sunlight

associated with the selected Sun Angle.

The settings defined on the Lighting Data tab are not related to how the shadow is displayed in floor plan view: they only affect rendered 3D views in which lighting and shadows can display.

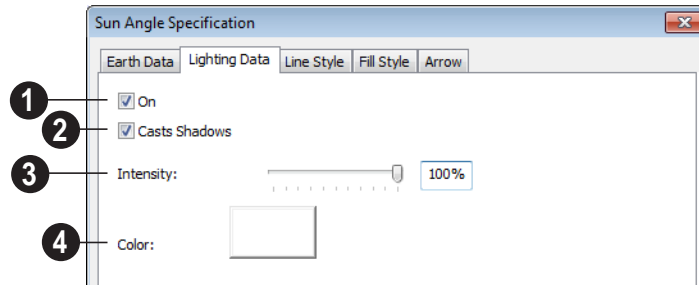

1 Check **On** to specify the selected Sun Angle as a Parallel Light source. See “Parallel Lights” on page 705.

If there is more than one defined Sun Angle, the renderer selects the first Sun Angle that is turned on. To make sure you are rendering the correct Sun Angle, make sure all others do not have this box checked.

2 Check **Casts Shadows** to have this light source cast shadows. These shadows are similar to the shadow shown in floor plan view, but may render differently based on the presence of other light sources.

3 Use the **Intensity** slider bar or text field to define the relative strength of the light source. The time of day as set on the Earth Data tab does not affect how the Sun Angle renders as a light source, but this does.

4 Click the **Color** button to select a color for the sunlight associated with the selected Sun Angle. See “Color Chooser Dialog” on page 652.

Line Style Tab

For information about the Line Style tab, see “Line Style Tab” on page 781.

Fill Style Tab

The settings on the Fill Style tab control the appearance of the selected Sun Angle’s shadow in floor plan view. For information about the settings on this tab, see “Fill Style Tab” on page 792.

Arrow Tab

For information about the settings on the Arrow tab, see “Arrow Tab” on page 783.

Rendering Techniques



Any camera view, cross section/ elevation view, or overview can be

generated using one of several rendering techniques to produce views for a range of

different purposes: from detail drawings to artistic presentation views. When a 3D view is active, select **3D> Rendering Techniques** to access these tools.

There are two ways to create a view using a particular rendering technique:

- Create a 3D view, then select the desired rendering technique from the menu.
- Select the desired rendering technique in the **Camera Defaults** dialog, then create a 3D view. See “Camera Defaults Dialog” on page 665.

Most of the Rendering Techniques have default settings that control their initial appearance. Once a view is created, these settings can be adjusted for that particular view in the **Rendering Technique Options** dialog. See “**Rendering Technique Options**” on page 713.

If a camera view is saved, its Rendering Technique settings are saved, as well. See “Saving & Printing 3D Views” on page 690.

 The Watercolor technique requires more time to generate than other Rendering Techniques. To save time, adjust the camera's perspective before using one of these techniques. See “Editing 3D Views” on page 684.

Standard Rendering

 **Standard** rendering is a photo-realistic technique that represents materials using textures, models lighting, and can also display shadows. Surface edge lines are not drawn and no special colors or effects are applied. Lighting is limited to the room containing the camera and the capabilities of your video card.

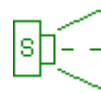

In floor plan view, the camera symbol for a view using the **Standard** technique displays an S in its center. See “Displaying 3D Views” on page 677.

Standard rendering requires a video card that supports OpenGL 2.0.

Vector View



In Vector Views, surface edge lines are drawn and pattern lines and colors are used to represent materials. Textures and lighting are not used, and special colors and effects are not applied.

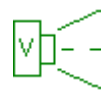
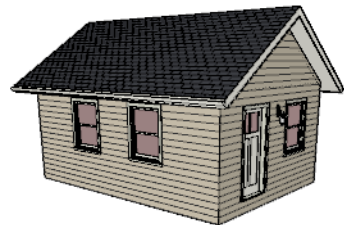

In floor plan view, the camera symbol for a view using the **Vector View** technique displays a V in its center.

Glass House



Glass House rendering uses different shades of a single color to display the

model with surface edge lines and semi-transparent surfaces. Lighting is not modeled, and materials are not represented, so neither pattern lines nor textures are used.





In floor plan view, the camera symbol for a view using the **Glass House** technique displays a G in its center.

Technical Illustration

 **Technical Illustration** rendering draws surface edge and pattern lines, and uses shades of two colors, Warm and Cool. The warm shade is applied to surfaces that face the light source in the view, and the cool shade, to surfaces that face away from it.

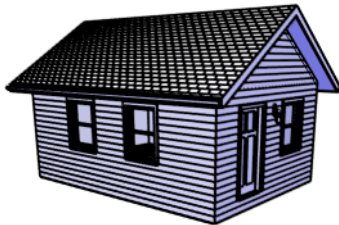
Only one light source is used: the light with the highest Intensity found in the room containing the camera. In exterior views, this light is always the Default Sun Light. Lighting is modeled as non-photorealistic, stylized highlights.



 In floor plan view, the camera symbol for a view using the **Technical Illustration** technique displays a T in its center.

Technical Illustration requires a video card that supports OpenGL 2.0.

Watercolor

 Watercolor rendering uses textures to represent materials and models lighting, but approximates the effects of watercolor painting such as pigment pooling and flow.



 In floor plan view, the camera symbol for a view using the **Watercolor** technique displays a W in its center.

Watercolor requires a video card that supports OpenGL 1.5.

Note: In some plans, the Watercolor techniques may take a considerable amount of time. You can press the Esc key to cancel the rendering.

Rendering Technique Options



The settings in the **Rendering Technique Options** dialog allow you to control the specific effects of each rendering technique on an active 3D view. To access this dialog, create a camera view, cross section/elevation view, or overview and select **3D> Rendering Techniques> Technique Options**.

The **Rendering Technique Options** dialog can also be accessed by double-clicking the **Rendering Techniques**  parent button.

The settings in the **Rendering Technique Defaults** dialog are the same as those in the this dialog, but control the initial settings of each technique when it is first applied.

In the **Rendering Technique Options** dialog, select a technique from the list on the

left to make its options active on the right. When this dialog is first opened, the technique currently used by the view is selected. If the view is new, the settings are based on those in the **Rendering Technique Defaults** dialog.

As changes are made in the **Rendering Technique Options** dialog, the 3D view behind the dialog box automatically updates to reflect those changes for all techniques except Watercolor. To update views using these techniques, which take more time to draw than the others, click the **Update** button in the dialog.

When a 3D view is saved, its Rendering Technique Options settings are saved, as well. See “Saving 3D Views” on page 690.

Standard Rendering



There are no Rendering Technique Options for Standard rendering; however, you can specify the ambient lighting for rendered views in the **3D View**

Defaults dialog. See “3D View Defaults Dialog” on page 668.

There are a variety of other tools that affect the appearance of standard rendered views. See “Displaying 3D Views” on page 677.

Vector View



There are no Rendering Technique Options for Vector View rendering; however, a variety of settings that affect the appearance of Vector Views can be set in the

3D View Defaults dialog. See “3D View Defaults Dialog” on page 668.

There are a variety of other tools that affect the appearance of Vector Views. See “Displaying 3D Views” on page 677.

Glass House



The active 3D view immediately updates to reflect any changes made to

the Rendering Technique Options settings for Glass House renderings.

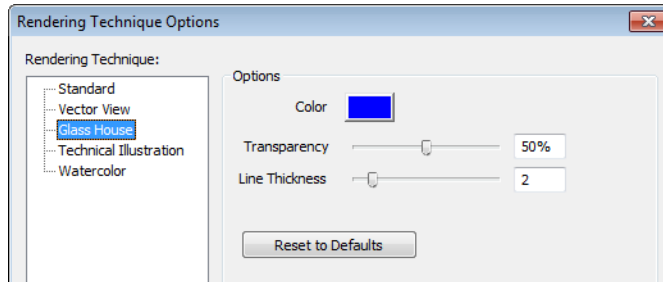

- Click the **Color** bar to select a color for the semi-transparent surfaces and lines in a Glass House view. See “Color Chooser Dialog” on page 652.
- Specify the **Transparency** of the surfaces in Glass House view. For example, to create a wireframe line drawing of your structure, turn transparency to full and minimize line thickness.
- Specify the **Line Thickness** of surface lines in Glass House view.
- Click **Reset to Defaults** to apply the Glass House settings defined in the **Rendering Technique Defaults** dialog. If clicked in the defaults dialog, the originally installed settings are restored.
- In the **Rendering Technique Defaults** dialog, the **Restore Initial Settings** button is available instead. Click this to reset the options on this panel to the originally installed settings.

Technical Illustration



The active 3D view immediately updates to reflect any changes made to

the Rendering Technique Options settings for Technical Illustration renderings.

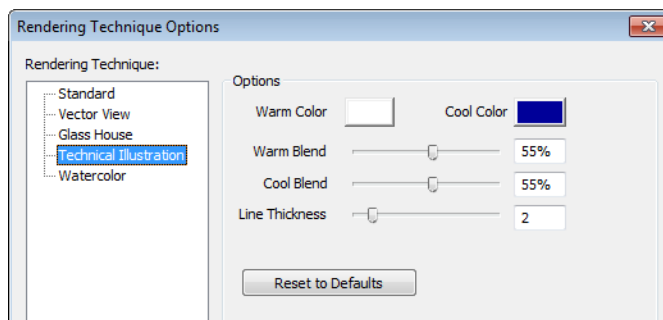

- Click the **Color** bar to select a **Warm Color** for surfaces that face the light source and a **Cool Color** for surfaces that face away from the light. See “Color Chooser Dialog” on page 652.
- Specify the **Warm Blend**, which is the degree to which the selected Warm Color is blended with original colors on well-lit surfaces in the view.
- Specify the **Cool Blend**, which is the degree to which the selected Cool Color is blended with original colors on shaded surfaces in the view.
- Specify the **Line Thickness** of all surface edge and pattern lines in the view.
- Click **Reset to Defaults** to apply the Technical Illustration settings defined in the **Rendering Technique Defaults** dialog..
- In the **Rendering Technique Defaults** dialog, the **Restore Initial Settings** button is available instead. Click this to reset the options on this panel to the originally installed settings.

Watercolor



In order for the active 3D view to reflect changes made to the Rendering Technique Options settings for Watercolor

renderings, you must click the **Update View** button in the dialog.

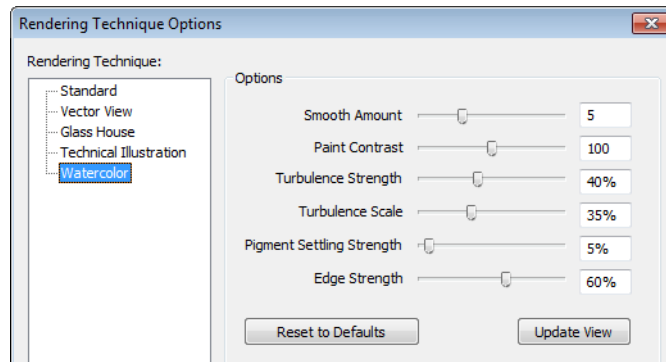

- Specify the **Smooth Amount**, which is the degree to which details are removed from the original view.
- Specify the **Paint Contrast**, which determines the extent to which variations in pigment color are used.
- Specify the **Turbulence Strength**, which produces “pooling”, or variations in the strength of pigment colors.
- Specify the **Turbulence Scale**, which controls the size of the areas of pooling.
- Specify the **Pigment Settling Strength**, which is creates the appearance of pigment settling into low areas in paper.
- Specify the **Edge Strength**, which is how well-defined surface edge lines are.

- Click **Reset to Defaults** to apply the Watercolor settings defined in the Rendering Technique Defaults dialog..
- In the **Rendering Technique Defaults** dialog, the **Restore Initial Settings** button is available instead. Click this to reset the options on this panel to the originally installed settings.
- Click **Update View** to apply any changes made to these settings to the active 3D view.
- Click **OK** to close the dialog and redraw the active 3D view based on these settings. Depending on your plan, this may take several moments.

Speeding up 3D View Generation

Depending on the speed of your processor, how many cores your processor has, and your computer's video memory, a 3D view may generate in a few seconds or less.

When you have a large, complex model with a lot of detail, many objects, extensive terrain, or patterns composed of many lines, it may take a few minutes to generate a 3D view of everything in the model. During this process, progress information may display in the Status Bar and in a message window.

There are several ways to speed up the generation time of views.



You can turn on "Show Screen Redraw Time" in the Preferences dialog to see how your changes affect 3D view generation time. See "Appearance Panel" on page 61.

Turn Off Layers



The display of objects in 3D views can be turned on or off by layer in the **Layer Display Options** dialog. Turning off the display of unneeded objects in 3D views can speed up 3D view generation time. See "Layer Display Options Dialog" on page 104.

Halt Generation with Esc Key

Using the Esc key, you can interrupt the modeling process at any point and display the incomplete model "as is." This is particularly helpful when you just need to reorient a model on the screen for a specific angle or view.

The Esc option allows you to place the view quickly, then press the F5 function key to refresh the display with all 3D faces intact.

Faster Rendering

To increase rendering speed, consider turning off some or all of the following options in the **Preferences** dialog. Bear in mind that render quality may be affected. See "Render Panel" on page 86.

Use **Optimizations** - Many video cards with OpenGL are capable of optimizing 3D views for subsequent redraws. Use of this option varies from video card to video card.

In general, you should leave this option turned on unless you are experiencing crashes when rendering.

Show Shadows - This option has the greatest impact on rendering speed and should only

be used for Final Views, unless you have an extremely fast OpenGL-accelerated video card.

When rendering shadows, a percentage complete value may display in the Status Bar.

In general, you should make sure you are only using a minimum number of lights to cast shadows.

Soft Shadows - Only used when Show Shadows is turned on, this significantly slows down the rendering speed. To save time, only use this option for Final Views.

Surface Backdrop - For some OpenGL-accelerated video cards, this option drastically increases rendering speeds. When turned on, this option creates surfaces that the backdrop is drawn on. When this option is turned off, the backdrop is sent directly to the video card. For most modern video cards, Off is the recommended setting.

Software Edge Smoothing - Only use this option for Final Views, as this slows down even the fastest video cards.

Use Textures - Some older video cards slow down significantly using textures. If you find that you need to uncheck this box often, you may want to upgrade your video card.

Use Triangles - This improves the quality of lighting effects on larger surfaces in certain views. Triangles are not used in the Standard, Technical Illustration, or Vector View Rendering Techniques.

View Panel Factors



Vector Views are drawn using an adaptive method that saves time by dividing the screen into horizontal and vertical panels.

The Options tab of the **3D View Defaults** dialog has two tuning factors that allow you to adjust the way the adaptive method works. See “Options Tab” on page 669.

Higher Quality Rendering

There are a number of settings you can use to improve the quality of your renderings. Some can affect rendering times, so you may want to consider optimizing them for your needs in Final Views only. See “Previews vs Final Views” on page 698.

Hardware Texture Filtering - Improves the appearance of textures, particularly on surfaces angled away from the camera. Not supported by some video cards.

Use Triangles - When you have lights in your scene, triangles are used to make those lights appear to illuminate objects properly. Generally speaking the smaller you set your **Triangle Size**, the slower the render, but the higher-quality result you can achieve.

Use Transparency - Necessary to display transparent or semi-transparent surfaces in a rendered view.

Software Edge Smoothing - Though slow, this can significantly improve the quality of 3D views.

Dimensions

Home Designer Pro provides a variety of dimensioning tools for measuring walls, doors, windows, and many other objects in various 2D and 3D views.

Dimensions can be used to accurately position objects relative to other objects. In addition, dimension lines and extensions can be selected and customized.

Chapter Contents

- Compatibility With Previous Versions
- Dimension Preferences and Defaults
- Dimension Defaults Dialog
- Auto Dimension Defaults Dialogs
- The Dimension Tools
- Displaying Dimension Lines
- Editing Dimension Lines
- Editing Extension Lines
- Moving Objects Using Dimensions
- Dimension Line Specification Dialog

Compatibility With Previous Versions

Dimensions function differently in versions 6.0 and later of Home Designer Pro than they did in their predecessor, Chief Architect

Home Edition 5.0. Being familiar with these changes is necessary if you plan to open plans from earlier versions.

Dimension Preferences and Defaults

There are a number of settings in the **Preferences** dialog that affect dimensions, as well as several dimension defaults dialogs.

Preferences



All plan and layout files save measurements in either Imperial or metric units. The type of unit used is

determined when the file is first created and cannot be changed later. See “Creating a New Plan or Layout” on page 42.

You can specify either metric or Imperial files to be used as the templates whenever you open a new, blank plan or layout file in the **Preferences** dialog. See “New Plans Panel” on page 71.

You can also specify the minimum on-screen display size for dimension numbers in the **Preferences** dialog. See “Appearance Panel” on page 61.

Default Settings



Select **Edit> Default Settings** or double-click the **Dimension Tools**

parent button or any of its child buttons (with the exception of the **Auto Exterior** and **Auto Interior Dimensions** tools). There are three dimension defaults dialogs:

- Dimension Defaults Dialog
- Two Auto Dimension Defaults Dialogs

When **Angle Snaps** are enabled, dimensions can be drawn at the **Allowed Angles** set in the **General Plan Defaults** dialog. Regardless of their angles, however, dimensions will only locate objects that are parallel to one another. See “General Plan Defaults Dialog” on page 58.

Dimension Defaults Dialog



Select **Edit> Default Settings**, expand the “Dimension” category, select “Dimensions”, and click the **Edit** button to open the **Dimension Defaults** dialog.

You can also double-click the **Dimension**

Tools parent button to open the this dialog.

The settings in this dialog are dynamic defaults, which means that any changes made here may affect existing dimension lines in the drawing that are using default values. See “Dynamic Defaults” on page 57.

Setup Tab

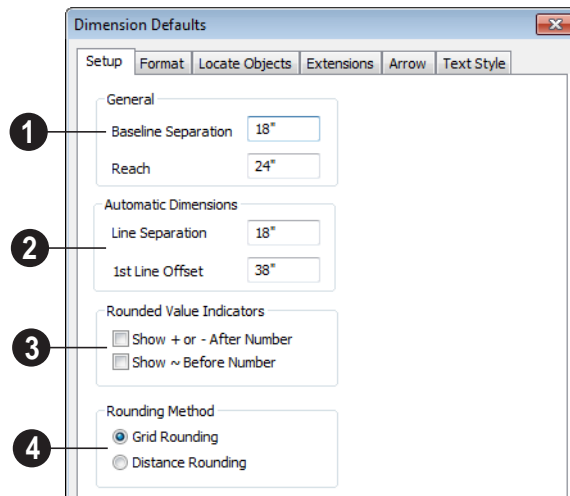

1 General -

- **Baseline Separation** - Specify the distance between Baseline Dimension lines in plan inches (mm). This value should always be greater than the font size. If two formats are used, it should be at least twice the font size.
- Specify how far manually drawn dimension lines **Reach** to locate walls and/or objects specified on the Locate Objects Tab. The default is 24" (450 mm) in plan files and 1" (10 mm) in layout.

2 Specify the initial spacing of **Automatic Dimensions**: specifically, Auto Exterior and Auto Interior Dimensions.

- Specify the **Line Separation**, which is the distance between Auto Exterior Dimension lines in plan inches (mm). This value should always be greater than

the font size. If two formats are used, it should be at least twice the font size.

- Specify the **1st Line Offset**, which is the distance between each wall and the nearest Automatic Dimension line that measures its length in plan inches (mm).

3 Specify the use and appearance of **Rounded Value Indicators**, which can display when the degree of accuracy in use is not sufficient to describe a dimension's true value.

- Check **+ or - After Number** to indicate that the actual dimension value is higher or lower than the value shown.
- Check **~ Before Number** to indicate dimension values that are not accurate with the ~ symbol.

4 **Rounding Method** - Specify how the sections of dimension lines that locate more than two objects are rounded.

- **Grid Rounding** ensures that the sum of the parts of a dimension line add up to the whole distance. To produce this result, some sections may not be rounded accurately. This is the recommended rounding method and is selected by default.
- **Distance Rounding** addresses each section of a dimension line individually,

which could result in the sum of these sections not being equal to the whole.

 You can avoid the appearance of inaccuracy that rounding may cause by placing the objects in your plan precisely and by drawing with Grid Snaps enabled. See “Grid Snaps” on page 112.

Format Tab

The settings on the Format tab allow you to specify the units, degree of accuracy and position of dimension numbers.

These settings are the same as those on the Format tab of the **Dimension Line Specification** dialog and the Dimension Format tab of the **Room Label Defaults**

dialog. See “Dimension Line Specification Dialog” on page 739 and “Room Label Defaults” on page 230.

The settings on this tab also control the format of numbers indicating object length in the Status Bar. See “The Status Bar” on page 31.

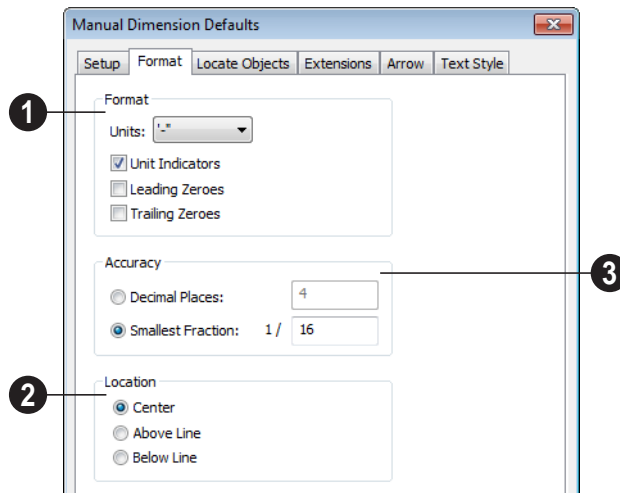

- 1 Specify the numbering **Format** for dimension numbers.
- Select the **Units** of measurement to be used by dimensions from the drop-down

list. The choices in this list correspond to all units measuring length specified in the **Preferences** dialog. See “Unit Conversions Panel” on page 71.

Note: Although you can select Imperial or metric units in any plan or layout, it is best to use the same unit type that the file uses to save measurements. See “Units of Measurement” on page 42. .

- Check **Unit Indicators** to display the unit of measurement along with the dimension number.
 - Check **Leading Zeros** to include the zero before a decimal less than 1 or to display 0' or 0" when the ft-in or '-'" unit formats is used.
 - Check **Trailing Zeros** to display trailing zeros at the end of decimal values. When the ft-in or '-'" unit formats is used and fractional inches are specified, 0" will be included.
- 2 Specify the **Location** of dimension numbers relative to the dimension line.
 - **Center** primary dimension numbers on the dimension line. If two formats are used, the primary format is placed above the line and the secondary format, beneath it.
 - Position dimension numbers **Above Line**.
 - Position dimension numbers **Below Line**.
 - 3 Specify the degree of **Accuracy** used by dimension numbers.
 - Select the **Decimal Places** radio button for dimension numbers in decimal format. In the text field, specify the number of decimal places to use, from 0 to 20. If 0 is used, no decimal places are used.
 - Select the **Smallest Fraction** radio button for dimension numbers using whole numbers and fractions. In the text field, specify the largest denominator to use, from 1 to 128. If 1 is entered, whole numbers are used.

Locate Objects Tab

The settings on the Locate Objects tab specify whether or not dimension lines locate specific types of objects. Changes made on this tab only affect new dimension lines, not those already drawn.

These settings affect dimension lines as they are drawn. Once created, their extension lines can be edited so that they locate objects in ways not specified here.

The Locate Objects tab is also found in the **Auto Exterior Dimension Defaults** dialog. See “Auto Dimension Defaults Dialogs” on page 727.

In the **Dimension Defaults** dialog when opened in a layout file, only the **CAD Objects** settings on this tab will be available.

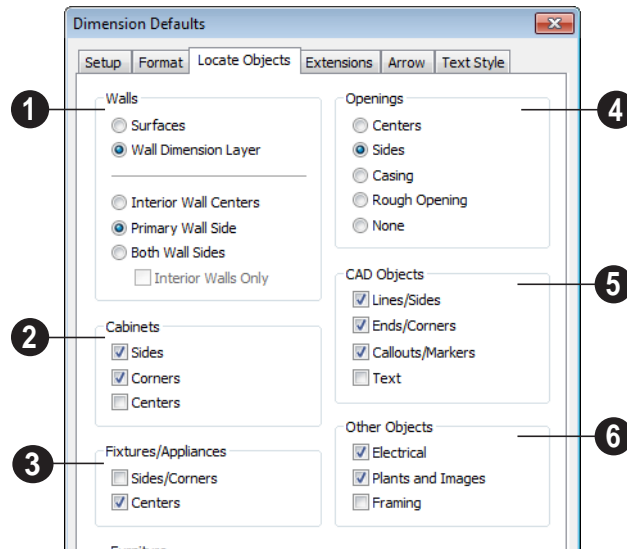

1 The **Walls** options affect Manual and Interior Dimensions and are also available in the **Auto Exterior Dimension Defaults** dialog. See “The Dimension Tools” on page 728 and “Auto Dimension Defaults Dialogs” on page 727.

The first two settings also determine the marked location in wall assemblies referred to by Extension Lines as well as the Reach and 1st Line Offset settings. See “The Dimension Layer” on page 210.

- Select **Surfaces** to locate exterior walls by outer surface and interior walls by one of their surfaces.
- Select **Wall Dimension Layer** to locate walls at the Dimension Layer. A wall’s Dimension Layer is specified in its wall type. See “Wall Type Definitions Dialog” on page 211.

The next four settings control how dimensions locate interior walls where they

intersect exterior walls, and only apply to interior walls drawn perpendicular to the exterior walls they intersect.

- Select **Interior Wall Centers** to have dimension lines locate the centers of interior walls. If Wall Dimension Layer is selected above, dimensions locate interior walls at the center of their Main Layers. See “The Main Layer” on page 209.
- Select **Primary Wall Side** to have dimension lines locate one side of interior walls.
- Select **Both Wall Sides** to have dimension lines locate both surfaces of interior and exterior walls. Wall thicknesses are also dimensioned.
- Check **Interior Walls Only** for dimensions to ignore the interior surface of exterior walls and the thicknesses of interior walls. Only available when Both Wall Surfaces is selected.

Note: Walls specified as No Locate will not be located by some dimension tools. See "No Locate" on page 196.

2 The **Cabinets** options affect how dimension lines locate objects cabinets and cabinet fillers.

- Check **Sides** to locate the sides of cabinet objects. The sides must be perpendicular to the dimension line.
- Check **Corners** to locate the corners of all cabinet objects within the Reach area. Angled cabinets are dimensioned to their corners at a right angle to the dimension line. A cabinet's front or sides do not need to be perpendicular or parallel to the dimension line for its corners to be located.
- Check to locate the **Centers** of all cabinet objects within the Reach area. A cabinet's front or sides do not need to be perpendicular or parallel to the dimension line for its center to be located.

3 The **Fixtures/Appliances** options affect how dimension lines locate appliances and other fixtures.

- Check to locate the **Sides/Corners** of appliances and other fixtures. For sides to be located, they must be perpendicular to the dimension line.
- Check to locate the **Centers** of all fixtures within the Reach area. An object's front or sides do not need to be perpendicular or parallel to the dimension line for its center to be located.

4 The **Furniture** options control how furnishings are located by dimension lines.

- Check to locate the **Sides/Corners** of furnishings. For sides to be located, they must be perpendicular to the dimension line.
- Check to locate the **Centers** of all furnishings within the Reach area. An object's front or sides do not need to be perpendicular or parallel to the dimension line for its center to be located.

Note: In cross section/elevation views, dimensions can only locate furniture at points where a surface is present.

5 The **Openings** options control how wall openings are located by dimension lines and are also available in the **Auto Exterior Dimension Defaults** dialog.

- Select **Centers** for dimensions to locate the centers of wall openings.
- Select **Sides** to locate both sides of wall openings. This option locates the nominal width - not the rough opening.
- Select **Casing** to locate both sides of wall openings at the outer edges of the casing. Because interior and exterior casing often has different widths, an opening may have different interior and exterior dimensions when this option is selected.
- Select **Rough Opening** to locate both sides of windows and doors at the rough opening.
- Select **None** for dimensions to not locate wall openings. This setting does not affect Auto Exterior Dimensions.

Note: Openings in walls specified as No Locate will not be located by Auto Exterior Dimensions. See "No Locate" on page 196.

6 The **CAD Objects** options control how dimension lines locate 2D CAD objects as well as CAD-based objects such as slabs and polyline solids, and stairs. .

- Check **Line/Sides** to locate lines and edges that are perpendicular to the dimension line. If the lines or edges are not perpendicular to the dimension line, they are not dimensioned.
- Check **Ends/Corners** to locate all ends of lines or corners of polylines, no matter what angle they are in relation to the dimension line.

- Check **Callouts/Markers** to locate these objects.

- Check **Text** to locate text objects.

7 The **Other Objects** options affect how dimension lines locate additional object types..

- Check **Electrical** to locate electrical objects. Use this option when you want to precisely position electrical objects.
- Check **Plants and Images** to locate these objects.
- Check **Framing** to locate these objects.

Extensions Tab

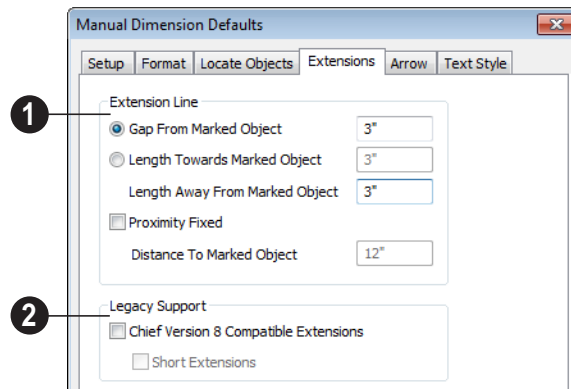

1 Specify the length and spacing of **Extension Lines** relative to the marked location on an object.

- Select **Gap From Marked Object** to specify the distance between the end of the extension line and the marked location in plan inches or mm. If the dimension line is moved, the extension line updates, and the size of this gap is maintained.

- Select **Length Towards Marked Object** to specify a fixed length for the portion of the extension line that extends from the dimension line toward the object it locates. If the dimension line is moved, this length remains the same but the size of the gap updates.

- Specify the **Length Away From Marked Object**, which is the length of the portion of the extension line that extends from the dimension line in the opposite direction of the object it locates.

- Check **Proximity Fixed** to specify a fixed distance between the marked object and the dimension line. You can only fix the proximity for a single extension line. See “Using Proximity Fixed” on page 737.
- **Distance to Marked Object** - When Proximity Fixed is checked, you can specify the distance from the dimension line to the marked object using a positive value.

Gap From Marked Object

+ Length Toward Marked Object

= Distance to Marked Object

Proximity Fixed only affects dimension lines that locate an object using an extension line. When a dimension line arrowhead points directly to the object without using an extension line, this option has no effect.

Auto Exterior Dimensions ignore Distance to Marked Object and use the default 1st Line Offset and Line Separation values. See “Setup Tab” on page 721.



Extension Line and Gap lengths are measured from the marked location on a wall. See “The Dimension Layer” on page 210.

- 2** **Legacy Support** - Specify how dimensions behave in files created in

Chief Architect Version 8 or prior. See “Compatibility With Previous Versions” on page 719.

- Check **Chief Version 8 Compatible Extensions** to make extensions function as they did in Chief Architect Version 8.
- Check **Short Extensions** to have short, uniform-length extension lines instead of extension lines that reach all the way to the objects they locate.

Note: If you select an extension line, Chief Version 8 Compatible Extensions will be turned off automatically.

Arrow Tab

For information about the Arrow tab, see “Arrow Tab” on page 783.

Text StyleTab

The settings on the Text Style tab control the size, font and other attributes of automatic, manually drawn, and temporary dimension line labels. See “Dimension Labels” on page 732.

For information about the settings on this tab, see “Text Style Tab” on page 766.

Temporary dimension labels always use the color assigned to their layer - not the color specified in the **Dimension Defaults** dialog.

Auto Dimension Defaults Dialogs



Select **Edit > Default Settings** or double-click either the **Automatic Dimension Tools**  or **Dimension**

Tools  parent button. Expand the **Dimension** category, select either of the “Auto” subcategories, and click the **Edit** button.

The settings in the two **Auto Dimension Defaults** dialogs allow you to control the initial appearance and behavior of dimensions created using either of the **Auto Dimension** tools.

You can also add buttons to your toolbars that you can click to quickly open either of

these dialogs. See “To add a button to a toolbar” on page 94.

The default **Line Separation** and **First Line Offset** values for automatic dimensions are set in the **Dimension Defaults** dialog. See “Setup Tab” on page 721.

General Tab

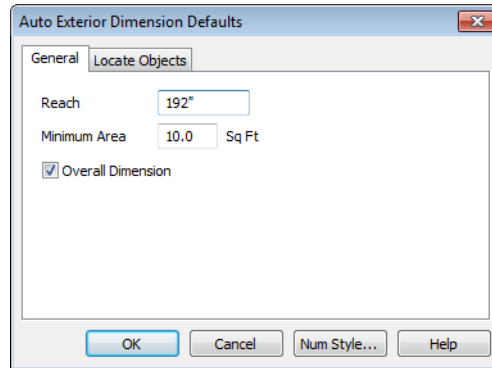

- Specify how far **Auto Exterior Dimension** lines **Reach** to locate objects set back from exterior walls. The default is 192 inches (4800 mm). If exterior walls are set back further than this distance, additional dimension lines are produced to dimension the set-back walls. Only available in the **Auto Exterior Dimension Defaults** dialog.
- Specify the **Minimum Area**: the minimum enclosed area needed for Auto Dimensions to generate.
- Check **Overall Dimension** to generate the overall dimensions of a plan when Auto Dimensions are created.

Locate Objects Tab

The settings on the Locate Objects tab are also found on the same tab of the **Dimension Defaults** dialog. The available options will vary in each defaults dialog, depending on the functionality of the tool. See “Locate Objects Tab” on page 723.

The Dimension Tools





Select **CAD > Dimensions** to access the Dimension Tools. Manually drawn

dimensions are created by clicking and dragging like other line-based objects and

can be drawn in floor plan view, cross section/elevation views, and on layout pages.

With the exception of **Angular**

Dimensions , dimension lines only locate objects that are parallel or nearly parallel to one another and should be drawn orthogonal, or at right angles, to the objects being located.

Dimension lines locate objects using **Object Snaps** , although they do not need to be enabled in order to draw dimensions. See “Object Snaps” on page 110. Bear in mind, though, that Object Snaps must be enabled in order to:

- Locate parallel objects drawn at angles other than Allowed Angles.
- Locate more than one object drawn in the same space, such as a CAD line drawn over a wall.

The zoom factor of the current view affects whether objects drawn close together are dimensioned or not. If you try to dimension an array of objects but the dimension line locates only the first and last objects along its path, **Zoom**  in on the objects and try again. Similarly, if you want to dimension between two objects but the dimension locates unwanted objects between them,

Zoom  out. See “Zoom Tools” on page 654.

Once created, both manually drawn and automatically generated dimension lines can be selected and edited. See “Editing Dimension Lines” on page 733.

Manual Dimensions



To display the distance between two objects, select **CAD> Dimensions> Manual Dimension** and drag a dimension line near or through the objects.

Manual Dimensions locate objects as specified on the Locate Objects tab and lying within the Reach distance specified in the **Dimension Defaults** dialog. See “Dimension Defaults Dialog” on page 720.

End-to-End Dimensions



Use the **End-to-End Dimension** tool to dimension between any two defined objects in floor plan view, cross section/elevation views and on layout pages.

Select **CAD> Dimensions> End-to-End**

Dimension , then click and drag the dimension from the first object to the second object. The dimension line snaps to each object, ignoring any other objects located between either end.

End-to-End Dimensions locate objects as specified on the Locate Objects tab and lying within the Reach distance specified in the **Dimension Defaults** dialog.

Angular Dimensions



The **Angular Dimension** tool measures the angle between any two straight edges, including lines, walls, the sides of boxes, the straight sides of polylines, cabinets, and soffits. Edges nested up to four levels deep within a CAD block can be dimensioned.

To create an angular dimension, click on the first edge to be dimensioned, then drag an arc and release on the second edge.

As with other dimension lines, Angular Dimensions adjust if one of the dimensioned objects is moved. Angular Dimensions can also be selected and moved using its edit handle. As it is moved, an Angular Dimension maintains the location of its arc center.

Like other dimension lines, an Angular Dimension can be included in a CAD block. When the block is exploded, the Angular Dimension may become invalid and disappear when edited or changed. If this occurs, it can be redrawn.

Interior Dimensions



Draw **Interior Dimension** lines parallel to walls in floor plan view to create interior dimensions.

The **Interior Dimension**  tool locates interior wall surfaces only. It does not dimension between layer surfaces in the same wall, and it does not locate walls unless it actually intersects them.

Interior Dimensions  locate either wall surfaces or the Main Layer, depending on the settings in the Locate Objects tab of the **Dimension Defaults** dialog. See “Locate Objects Tab” on page 723.



Point to Point Dimensions



The **Point to Point Dimension** tool places Point Markers at the start end and points of a dimension line as it is drawn

and dimensions between them. See “Markers” on page 762.

Point to Point Dimensions can be drawn in either of two ways:

- When the **Default**  edit behavior is active, a Point to Point Dimension places Point Markers at its start and end points, which it locates. Any objects along the dimension line’s length are ignored. See “Point Markers” on page 774.
- When the **Alternate**  edit behavior is active, a Point to Point Dimension locates objects along its length as well as objects or Point Markers at its start and end. See “Edit Behaviors” on page 120.

Point Markers can be selected and edited. See “Editing Markers” on page 764.

If the objects or point markers located by a **Point to Point Dimension**  line are moved, the dimension updates to reflect the change.

Objects and Point Markers located by a **Point to Point Dimension**  line can be accurately relocated by specifying new dimension values. See “Moving Objects Using Dimensions” on page 737.

Auto Exterior Dimensions



The **Auto Exterior Dimension** tool generates dimensions around a plan’s exterior in floor plan view. The dimension lines locate walls and openings as specified in the **Dimension Defaults** dialog. See “Locate Objects Tab” on page 723.

 Auto Exterior Dimensions do not generate properly if there is a gap in the exterior walls. For example, sometimes angled walls may not connect properly. If automatic dimensions do not generate, try Build> Wall> Fix Wall Connections .



Auto Exterior Dimension  locate objects as specified in the **Auto Exterior Dimension Defaults** dialog. See “Auto Dimension Defaults Dialogs” on page 727.

If you edit an **Auto Exterior Dimension**  line, it will be converted to a manual dimension, so if Auto Exterior Dimensions are later regenerated, your changes will not be lost.

There are a maximum of three rows of automatically generated dimensions per exterior wall direction. The innermost dimension line locates exterior walls, interior walls, and all openings in exterior walls. The second dimension line locates exterior and interior walls. The outermost dimension line is the overall exterior dimension.

Auto Interior Dimensions

 The **Auto Interior Dimensions** tool can be used in floor plan view in either of two ways:

- Select **CAD> Dimensions> Auto Interior Dimensions**  to generate interior dimensions measuring each wall on the current floor.
- Select one or more rooms and click the **Auto Interior Dimensions**  edit tool to generate interior dimensions that mea-

sure each wall defining the selected room(s).

Auto Interior Dimensions  lines are generated inside of the rooms they measure and locate walls, openings, and other objects as specified in the **Auto Interior Dimension Defaults** dialog. See “Locate Objects Tab” on page 723.

Auto Interior Dimensions  do not recognize the **No Locate** setting for walls. If a wall is specified as No Locate, Auto Interior Dimensions will locate it anyway. See “No Locate” on page 196.

Display Temporary Dimensions

 Temporary Dimensions display when an object is selected and show the distance between the object’s selected edge and other objects. Select **CAD> Dimensions> Display Temporary Dimensions** to turn on or off the display of temporary dimensions. This toggle affects all views and is saved between launches of Home Designer Pro.

As with other dimension lines, Temporary Dimensions only locate objects that are parallel or nearly parallel to one another. They will also locate the endpoints of CAD lines and the corners of objects located past the end of the selected edge, within 4 feet (1200 mm) of the point where you click to select the object.

A temporary dimension will not display when an object is selected if a manually drawn dimension line is already present that shows the same information.

Tape Measure



Use the **Tape Measure** tool to draw a temporary dimension line between any two points in the drawing area. The tool will place temporary markers at the start and

end points of the dimension line. These points and the line both disappear when you release the mouse button. If **Object Snaps**



are enabled and an object is located by the temporary line, you can snap to it.

Displaying Dimension Lines



The display of dimension lines is controlled in the **Layer Display Options** dialog. See “Displaying Objects” on page 102.

Dimension lines created by any of the dimension tools share the same components.

- **Dimension Lines** run parallel with the distance being measured.
- **Extension Lines** are perpendicular to dimension lines, indicating what they locate. If a dimension line locates more than two objects, extension lines divide the dimension line into segments.
- **Arrowheads** display at the intersections of dimension and extension lines.
- **Dimension Labels** display at the midpoint of dimension line segments and indicate the distance that each segment measures.

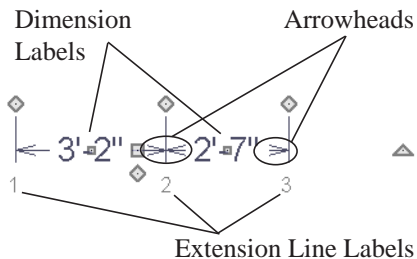

If a manual dimension line is on a layer that is turned off and you select an object located by that dimension line, it will display for reference using the Move color specified in the **Preferences** dialog. See “Colors Panel” on page 63. This will happen only if **Display**

Temporary Dimensions  is turned on. See “Display Temporary Dimensions” on page 731.

Extension Lines

If a dimension line is offset from the objects it locates, extension lines can help clarify exactly what is being located. You can specify the default length of extension lines in the **Dimension Defaults** dialog. See “Extensions Tab” on page 726.

Once drawn, the appearance of extension lines can be edited. See “Editing Extension Lines” on page 735.

Dimension Labels

Manually drawn, automatic and temporary dimension labels use the Text Style specified in the **Dimension Defaults** dialog. Unlike many objects that use Text Styles, by default dimensions use a Text Style specified in the defaults dialog rather than the Text Style assigned to their layer. See “Text StyleTab” on page 727.



Like other text, dimension labels are subject to scaling. For example, A font size of 6" prints a 1/8" tall number at 1/4" = 1' scale. A font size of 125 mm prints a 3 mm tall number at 1 m = 50 m scale. See "Printing Text and Dimensions" on page 851.

By default, dimension labels have a solid fill that is the same as the **Background Color** set in the **Preferences** dialog. You can instead specify that labels use a Text Style that has a transparent or other fill.

You can also specify the minimum size of dimension numbers displaying on screen in the **Preferences** dialog. See "Appearance Panel" on page 61.

Labels can be centered on dimension lines or located either above or below them. See "Format Tab" on page 722.

Dimension labels have their own edit handle and can be moved when a dimension line is selected.

Dimension Arrowheads

You can specify the style, color and size of dimension arrows in the **Dimension Defaults** and **Dimension Line Specification** dialogs. See "Arrow Tab" on page 783.

The arrow at the end of a dimension line will not display if it is close enough to another dimension arrow that the two will overlap. A typical example of this is where two sections of an Interior Dimension locate two sides of an interior wall.

Editing Dimension Lines

With the exception of Temporary Dimensions, dimension lines can be selected and edited using the mouse, the edit toolbar buttons, and the **Dimension Line Specification** dialog. See "Dimension Line Specification Dialog" on page 739.

If an Auto Exterior Dimension line is edited, it will no longer be considered an automatic dimension line and will not be deleted and replaced the next time the **Auto Exterior Dimensions**  tool is used.

Dimension line numbers and extension lines can be individually selected, moved and deleted, and new extension lines can be added. See "Editing Extension Lines" on page 735.

Using the Mouse

When a dimension line is selected, its edit handles can be seen. There are four types of dimension line edit handles. More than one of some types display, depending on how many extension lines are present.

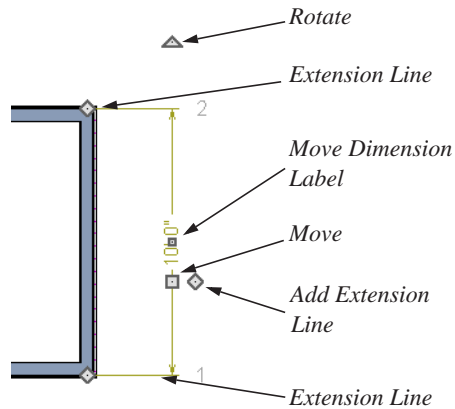



- The **Extension Line** handles mark the location being dimensioned and are used to move or delete extension lines. See “Moving Extension Lines” on page 736.
- The **Add Extension Line** handle displays to the side of the Move handle and is used to add extension lines to the dimension line. Dimension lines do not extend unless an object can be located. See “Adding Extension Lines” on page 735.
- The small, square **Move Dimension Label** handle is located at the center of the selected label. Use this handle to move the dimension number for each dimension line section. The pointer changes to a four-headed arrow \leftrightarrow when moved over this handle.
- The **Move** handle is located where you clicked to select the dimension line and is used to move the entire dimension line, including any subsections, perpendicular to itself. Extension lines are resized as appropriate. The pointer changes to a two-headed arrow \leftrightarrow when moved over this handle.

- The **Rotate** handle is located one plan foot past the end of the dimension line and is used to rotate the dimension line.

Using the Edit Tools

Dimension lines can be repositioned, copied, and deleted using the edit toolbar buttons just like other objects in the program can. See “The Edit Toolbar” on page 29.

Click the **Edit Dimension Ends**  edit button to edit the dimension line using edit handles similar to those on line based objects. See “Editing Line Based Objects” on page 127.

Edit Dimension Ends  is useful for locating a point on an object that it might not locate otherwise, such as the corner of a polyline.

Click the **Edit Extensions**  edit button to edit the lengths of the selected dimension’s extension lines. See “Editing Extension Lines” on page 735.

Dimension Number Size

The initial size of dimension numbers is specified in the **Dimension Defaults** dialog. See “Dimension Defaults Dialog” on page 720.

You can specify number height for individual dimension lines in the **Dimension Line Specification** dialog. See “Dimension Tab” on page 740.

As with text and other objects, dimension number size is subject to scaling when sent to layout or printed. See “Printing Text and Dimensions” on page 851.

Copying and Pasting Dimension Lines

Dimension lines can be copied and pasted into any view type that supports dimensions. If a dimension line is copied independent of the objects it originally locates, the pasted dimension line will locate point markers.

Deleting Dimension Lines

There are several ways to delete dimension lines.

You can select any manual or automatic dimension line or group of dimension lines, then press the Delete key or click the

Delete  edit button. See “Deleting Objects” on page 171.

The **Delete Objects** dialog allows you to delete all manually drawn and/or automatic dimension lines at once. See “Delete Objects Dialog” on page 171.

Individual dimension line segments located between extension lines can also be deleted. If a segment is located between two other segments along the same dimension line, that dimension will be broken in two.

To delete a portion of a dimension line

1. Select any **Dimension Tool** aside from Angular or Auto Exterior Dimensions.
2. Click and drag a manual dimension line over the segment that you wish to remove, dragging from extension line to extension line.

Editing Extension Lines

Extension lines can be added, edited, and deleted using the mouse. Extension lines are also affected by settings in the **Dimension Line Specification** dialog. See “Extensions Tab” on page 741.

Adding Extension Lines

To add an extension line

1. Select the dimension line.
2. Click the diamond-shaped Add Extension Line edit handle which displays near the Move edit handle. The pointer changes to a two-headed arrow \leftrightarrow .

3. Drag the handle to the object that you want to locate with a new extension handle. This example adds an extension line to the window edge.

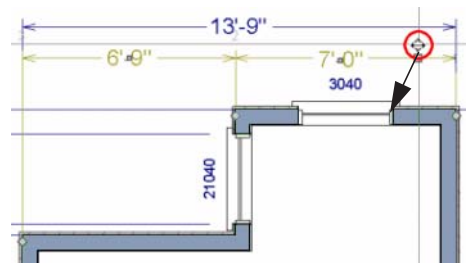

4. Release the mouse button to add an extension line.

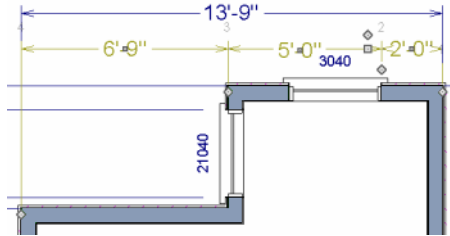

Moving Extension Lines

Extension lines can be moved to locate the centers, sides, or surfaces of most objects. In this example an extension line is moved from the window's edge to the center.

To move an extension line

1. Select the dimension line it is connected to, not the extension line itself.
2. Click the Extension Line edit handle. The pointer changes to a two-headed arrow ↔.

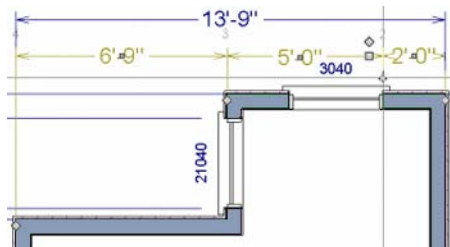

3. Drag the handle to a new location. The extension line snaps to possible marks as the handle is moved.
4. Release the mouse button at the new location.

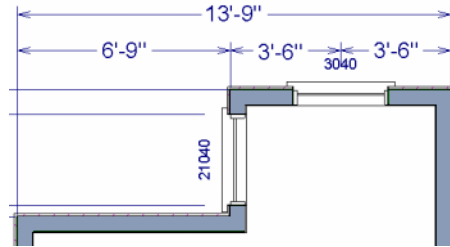

 Not all library symbols can be located by a dimension line as it is drawn. Once a dimension is drawn, however, you can move or add an extension line to locate the library object.

Resizing Extension Lines

You can resize extension lines in the **Dimension Line Specification** dialog or using their edit handles. See “Extensions Tab” on page 726.

To resize an extension line

1. Select the extension line or select the dimension line and click the **Edit Extensions**  edit button to display two handles along the extension line.



2. Click either handle, turning the pointer into a two-headed arrow ↔.
3. Extend or contract the extension line and release the mouse.

Using Proximity Fixed

The **Proximity Fixed** option allows you to specify a fixed length for one extension line that will not change if the object the extension line locates is moved.

To use Proximity Fixed

1. Select a dimension line that locates multiple independent objects and note the Extension Number of extension line that you would like to have a fixed length.
2. Open the **Dimension Line Specification** dialog and go to the Extensions tab. See “Extensions Tab” on page 726.
 - Select the Extension Number that you noted in step 1 from the **Selected Extension** drop-down list.
 - Check **Proximity Fixed**.
 - Specify the desired **Distance to Marked Object**, which is the distance from the selected dimension line to the object that the Selected Extension locates. This distance includes the Gap From Marked Object.
 - Click **OK**.

To see how Proximity Fixed works, select the object that the extension line with Proximity

Fixed specified and move it. Notice that the dimension line moves in response and that all extension lines’ lengths adjust except for the one with Proximity Fixed.

Deleting Extension Lines

When an extension line is deleted, the remaining dimensions update. If a dimension line has only two extension lines, they cannot be deleted.

To remove an extension line

1. Select the dimension line it is connected to, not the extension line itself.
2. Click the Extension Line edit handle.

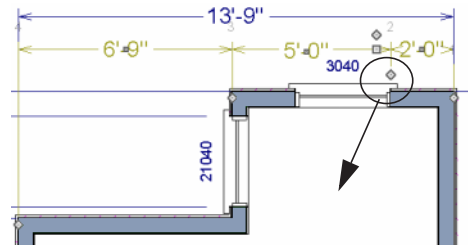

3. Drag it perpendicular to the direction of the arrows, away from any dimension-able object, and release the button when the extension line disappears.

Moving Objects Using Dimensions

Most objects can be moved by changing an automatic, manual or temporary dimension value that locates it. This technique can be applied in nearly any situation where dimensions are present, including angular dimensions. See “Moving Objects” on page 152.

In addition, some objects can be resized using dimensions. See “Resizing Objects” on page 157.

Your pointer indicates which dimensions can be used to relocate the selected object by changing to a pointing hand icon.

Another way to tell is to select an object and drag it in the desired direction. As you drag, note which dimensions update. These dimensions are the dimensions that can be used to move that object.

To move an object using dimensions

1. Select the object and click on a dimension line that locates it. An inline text field opens at the location where you clicked.
 - The actual distance displays in the text field.
 - If the dimension is locating two different objects, the **Move Edge** and **Move Entire Object** buttons display to the right of the text field.

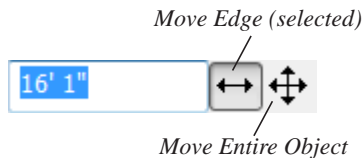

- If the dimension describes a selected wall's length, the **Move Start**, **Move End** and **Move Both Ends** buttons display to the right instead.

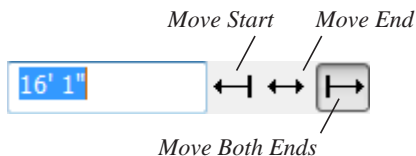

2. Click the **Move** button of your choice.
3. Enter a new value in text field.
 - To use a different unit, include its indicator after the value. To move the selected object past a second object, to

its opposite side, enter a negative value.

4. The selected object moves or resizes when you press the Enter key or click outside of the text field.
5. If **Bumping/Pushing**  is enabled, the object being moved will bump into any objects in its move path and not move the entire distance. Hold down the Ctrl key when you press Enter to override this move restriction. See "Bumping/ Pushing" on page 152.

To resize an object using dimensions

1. Select the object along the edge that you would like to move. See "Selected Edge" on page 125.
2. Click on a dimension line that indicates its distance from the object's opposite side.
3. In the inline text field, enter a value.
4. Click **Move edge** to move the selected edge only.
5. The selected edge moves, resizing the object, when you press the Enter key.



You can cancel a move or resize operation using dimensions at any time by pressing the Esc key.

Resizing a House Using Exterior Dimensions

When resizing a house using dimensions, it is important to work your way around the house in one direction. Relocate one wall at a time in succession so that you do not redefine the same dimension more than once.

For more information, see “Adjusting Wall Positions” on page 36 of the User’s Guide.

Using Angular Dimensions

 **Angular Dimensions** are useful for adjusting the angles of polyline-based objects and walls.

To change an angular dimension

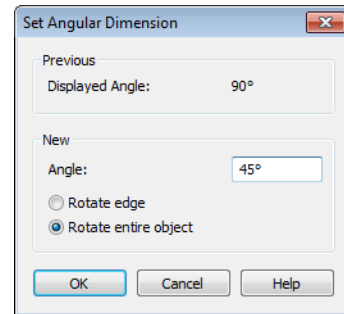

1. Draw an **CAD> Dimensions> Angular Dimension** , then click and drag to draw an arc within the angle you wish to measure.
2. Select the edge that you want to move.
3. Click the dimension value to open the **Set Angular Dimension** dialog.

The **Set Angular Dimension** dialog indicates the **Previous Value** in degrees, minutes and seconds.



4. Enter a value in the **New Value** field.
5. Specify what you want to rotate:
 - Select **Rotate Edge** to move the selected edge when you click OK, or
 - Select **Rotate entire polyline** to rotate the entire object about the corner formed by the edges that the Angular Dimension locates, maintaining the previous value of that angle.
6. Click **OK** to apply the change.

Dimension Line Specification Dialog

 To open the **Dimension Line Specification** dialog, double-click a dimension line using the **Select Objects**  or **Manual Dimension**  tool, or select a

dimension line or group of dimension lines and click the **Open Object** edit button.

The settings in this dialog are dynamic defaults. See “Dimension Defaults Dialog” on page 720.

Dimension Tab

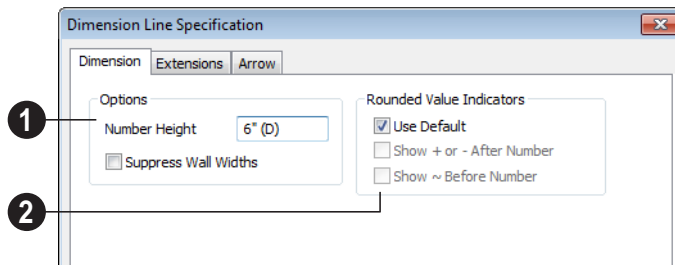

1 Options - Specify the size and display of wall widths attributes for the selected dimension line. The minimum on-screen size can be set in the **Preferences** dialog. See “Appearance Panel” on page 61.

- Specify the **Number Height** for the selected dimension. Type “d” in the box to reset the number size to the default.



Dimension Number Height is subject to scaling. For example, A Number Height of 6” prints a 1/8” tall number at 1/4” = 1’ scale. A Number Height of 125 mm prints a 3 mm tall number at 1 m = 50 m scale.

- Check **Suppress Wall Widths** to suppress those portions of the dimension line that measure between two surfaces of the same wall. Both sides of a wall may still be located, but its width will not display.

This option is checked by default for most manually drawn dimensions, but is unchecked for Interior Dimensions.

2 Specify the use and appearance of **Rounded Value Indicators**, which can display when the degree of accuracy in use is not sufficient to describe a dimension’s true value.

- Check **Use Default** to use the default indicator(s). Uncheck this box to make the options that follow active.
- Check **+ or - After Number** to indicate that the actual dimension value is higher or lower than the value shown.
- Check **~ Before Number** to indicate dimension values that are not accurate with the ~ symbol.

Dimension Tab for Angular Dimensions

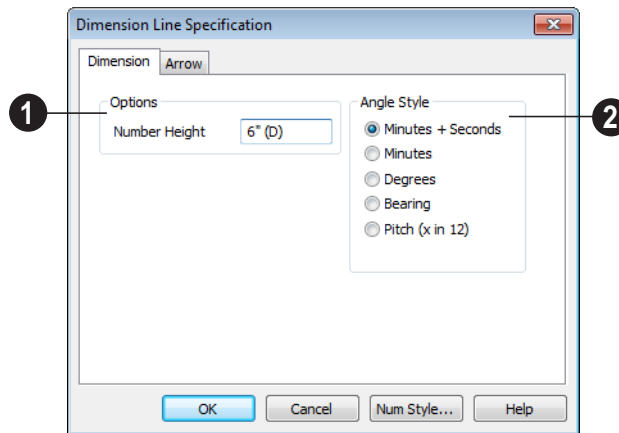

1 **Number Height** - Define a number height for the selected dimension. Type “D” in the box to reset the number size to the default.

2 **Angle Style** - Click a radio button to specify the how the selected angular dimension line’s angle value displays. See “Number Style/Angle Style Dialog” on page 89.

Extensions Tab

The Extensions Tab is not available for dimensions selected as a group or for **Angular Dimensions** .

 Opening this tab will turn off Version 8 Compatible Extensions if it is enabled in the Dimension Defaults dialog. See “Extensions Tab” on page 726.

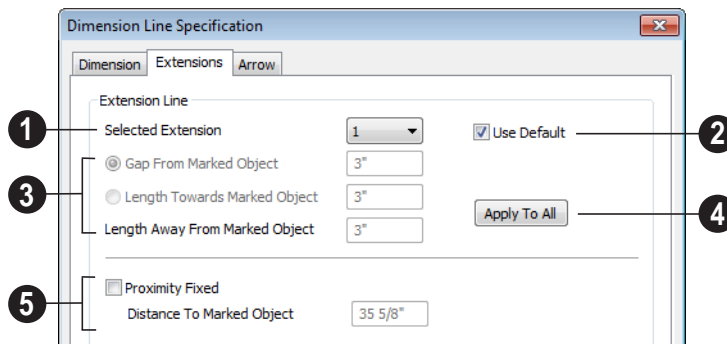

1 **Selected Extension** - Choose an extension line associated with the currently selected dimension from the drop-down list. The selected extension can then be edited here.

Each extension line's number displays beside it when a dimension line is selected.

2 Uncheck **Use Plan Default** to enable the three settings that follow. Check this box to restore the default settings to the Selected Extension line. See "Dimension Defaults Dialog" on page 720.

3 These settings are the same as those found on the Extensions tab of the **Dimension Defaults** dialog, but apply to the extension lines associated with the selected dimension line only. See "Extensions Tab" on page 726.

4 Click **Apply to All** to apply the settings for the Selected Extension line to all extension lines associated with the selected dimension.

5 Check **Proximity Fixed** to specify a fixed distance between the marked object and the dimension line. You can only fix the proximity for a single extension line.

- **Distance to Marked Object** - When Proximity Fixed is checked, you can specify the distance from the dimension line to the marked object using a positive value. See "Extensions Tab" on page 726.

Arrow Tab

For information about the settings on this tab, see "Arrow Tab" on page 783.

Text, Callouts & Markers

Text, callouts and markers are an ideal way to draw attention to special details of your drawings. Text can be added in floor plan view, in cross section/elevation views, and to layout pages.

Text lines with arrow can be attached to text objects, allowing you to direct attention to specific plan details.

Chapter Contents

- Text Defaults and Preferences
- Fonts and Alphabets
- The Text Tools
- Creating Text, Callouts and Markers
- Displaying Text, Arrows, Callouts and Markers
- Rich Text Specification Dialog
- Text Specification Dialog
- Editing Text
- Copying & Pasting Text
- Text Arrows
- Callouts
- Callout Specification Dialog
- Editing Callouts
- Markers
- Marker Specification Dialog
- Editing Markers
- Text Styles

Text Defaults and Preferences



Text Defaults can be accessed by selecting **Edit> Default Settings** in any view in which text can be created. Click the "+" next to **Text, Callouts and Markers** to display the sub-headings. See “Default Settings vs Preferences” on page 56.

The default settings for Rich Text, Callouts, Markers, and Arrows determine what these objects look like when they are first created. Text Style Defaults determine the appearance of text associated with things like dimensions and object labels.



Changes made to default settings do not alter existing text objects, so it is a good idea to go over these settings before placing text.

Text Style Defaults

Select “Text Style” from the list in the **Default Settings** dialog and click the **Edit** button to open the **Saved Text Style Defaults** dialog.

The **Text Style Defaults** dialog allows you to specify the attributes of the various Text Styles in use in the current file. See “Text Styles” on page 765.

Rich Text Defaults

Double-click the **Rich Text**  or **Leader Line**  tool to open the **Rich Text Defaults** dialog and specify the default appearance of Rich Text objects.

The **Rich Text Defaults** dialog is similar to the **Rich Text Specification** dialog. See “Rich Text Specification Dialog” on page 747.

Leader Lines  and **Text Lines with**

Arrows  use the same default layer as Rich Text, so by default they have the same color, line weight and line style. See “Layers” on page 101.

Callout Defaults

Double-click the **Callout**  tool to open the **Callout Defaults** dialog and specify the default appearance of callouts.

The **Callout Defaults** dialog looks almost the same as the **Callout Specification** dialog. See “Callout Specification Dialog” on page 760.

Marker Defaults



Double-click the **Marker**  tool to open the **Marker Defaults** dialog and specify the default appearance of markers.

The **Marker Defaults** dialog looks almost the same as the **Marker Specification** dialog. See “Marker Specification Dialog” on page 763.

Arrow Defaults

Double-click the **Text Line with Arrow**  tool to open the **Arrow Defaults** dialog.

The settings in the **Arrow Defaults** dialog determine the initial settings for arrows

drawn using the **Leader Line** , **Text Line with Arrow**  and **Line With Arrow**  tools. These settings also determine the

initial appearance of arrows when they are added to CAD lines, arcs, and polylines.

The **Arrow Defaults** dialog looks almost the same as the Arrow tab of the **Line Specification** dialog. See “Arrow Tab” on page 783.

 Avoid typing any text in any text Defaults dialog unless you want it to be present in all text objects you create.

Preferences



Specify the number of segments for new leader lines and whether pressing the Enter key creates a new line of text or closes the **Text Specification** dialog in the **Preferences** dialog. See “Text & Page Setup Panel” on page 66.

Fonts and Alphabets

Home Designer Pro allows you to use any font found in your Windows Fonts directory.

For best printed results, using true-type or open-type fonts is recommended.

International Alphabets

The **Rich Text**  tool supports unicode alphabets and characters. In order to use a unicode alphabet or characters, the appropriate language support must be installed on your computer.

Special characters can be added to any **Rich Text**  object by:

- Copying and pasting the character from another application;
- Copying and pasting the character from the Windows Character Map;
- Typing the keystroke associated with the character.

See “Copying & Pasting Text” on page 756.



Character Size

Text, callouts, markers as well as dimension numbers can be sized to 1/128” accuracy when Inches is used as the number style (0.078125 mm when Decimal mm is used). See “Number Style/Angle Style Dialog” on page 89.

Either of two font sizing methods may be used:

- The default method specifies text size as the measurement from the baseline to the topmost part of the capital letter A. This method is similar to that used in most CAD programs.
- Alternatively, you can use a font sizing method similar to most word processing applications, where size is based on information stored in the font. This information varies from font to font and is responsible for apparent differences in font height.

To size **Rich Text**  based on the size of the capital letter A, use **CAD Style Font Sizing**. See “Appearance Tab” on page 750.

To size **Callouts** , **Markers**  and dimension numbers based on font information, use **Legacy Compatible Size**.

The sizing method used for text objects can be set as defaults and also specified per object in objects' specification dialogs. See

"Text Defaults and Preferences" on page 744.

The sizing method used for dimensions can only be specified in the **Dimension Defaults** dialog. See "Dimension Defaults Dialog" on page 720.

The Text Tools



Select **CAD> Text** to access the **Text Tools**. These tools are available in floor plan view, in cross section/elevation views, and in layout files.



The **Rich Text** tool is used to create text objects.



The **Text Line with Arrow** tool is used to connect text and another object with an arrow. See "Text Arrows" on page 757.



Text with Arrow tool places a Rich Text object with an arrow attached.



The **Callout** tool is used to place callouts. See "Callouts" on page 759.





The **Marker** tool is used to place markers for **Level Lines**, **Test Borings** and **Point Markers**. See "Markers" on page 762.

Creating Text, Callouts and Markers

Text, callouts and markers can be created in floor plan view, in cross section/elevation views, and on layout pages.





Once created, text, callouts and markers can be selected and edited in a variety of ways. See "Editing Text" on page 754.

To create Rich Text

1. Select **CAD> Text> Rich Text** .
2. Type or paste the desired text into the Text Field.
3. Use the options  to change the font, style and size of any portion of the text.

4. When you are finished, simply click outside of the Text Field to close it and the Edit Bar. The **Rich Text**  tool remains active, so you can click and drag to create additional Text objects if you wish.

Note: If you do not type anything in the Text Field, a text object will not be created when you click outside of it.

Rich Text  , **Callouts**  and **Markers**  can also be created by clicking where you want the upper left corner of the object to be created. The object's specifica-

tion dialog will open: enter text and click OK.

You can also create lines with arrows connecting the text that you create to items in the drawing. See “Text Arrows” on page 757.

Text and CAD Objects

Text can be used in combination with CAD objects to create legends, title blocks, and a wide variety of other details. See “CAD Objects” on page 769 and “Layout” on page 863.

Displaying Text, Arrows, Callouts and Markers



As with other types of objects, the display of Text objects is controlled in the **Layer Display Options** dialog. Text objects are located on layers with “Text” at the beginning of the layer name, such as “Text, Callouts”. See “Layer Display Options Dialog” on page 104.

Text objects can only be displayed in views where text can be created.

The display attributes of each individual text object can be controlled independent of the layer it is placed on. See “Rich Text Specification Dialog” on page 747.

To move text to a different layer, select the text object or group of text objects, then click the **Open Object**  edit button to open the **Text Specification** dialog. The selected text object’s layer can be changed on the Line Style tab. See “Line Style Tab” on page 781.

Rich Text Specification Dialog

 The **Rich Text Specification** dialog opens if you select the **Rich Text**  tool and then click once in the drawing area.

You can also open this dialog by selecting one or more **Rich Text**  objects, then clicking the **Open Object** edit button.

When **Rich Text**  objects are group-selected, the text content and zoom factor cannot be changed, but everything else can be.

The **Rich Text Specification** dialog is similar to the **Rich Text Defaults** dialog but affects the selected text rather than all subsequently created text objects. See “Text Defaults and Preferences” on page 744.

Text Tab

The settings on the Text tab allow you to type the selected Rich Text object’s content and control many aspects of its appearance, including its font, size, color and style.





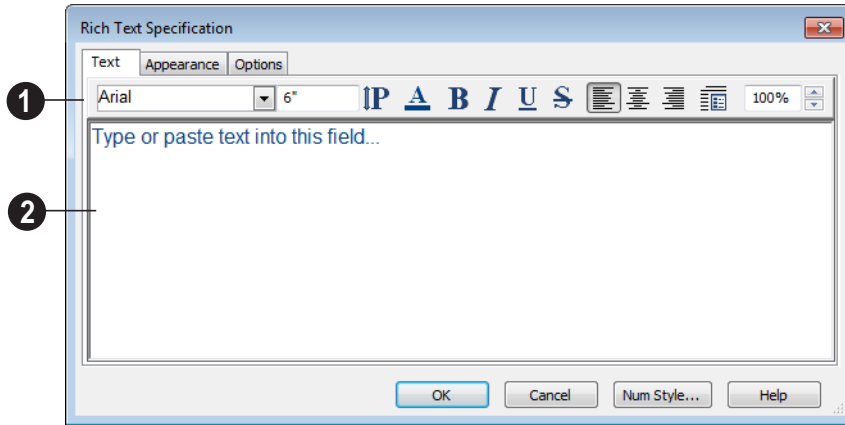





You can specify the appearance of the text before typing, and can also select and change the attributes of all or portions of the text content after it is typed. To change text that

already exists, simply highlight it using the mouse and/or the Shift + arrow keys and then make any needed changes to its attributes.



1 Use the options on the Edit Bar, which displays above the Text Entry field, to change the font, style and size of the text.

Select the desired options before typing to affect the text as it is typed, or select some or all of the text and then specify which options to apply to it.

- Select a **Font** from the drop-down list.
- Specify the **Text Size** in drawing units. When imperial Inches or Feet and Inches are used, accuracy to 1/128" is possible.
- Click the **Print Size**  button to open the **Printed Size Input** dialog. See “Scaling Text” on page 755.
- Click the **Color**  button to specify the color of the selected or subsequently typed text. See “Color Chooser Dialog” on page 652. If **Layer Color Text** is checked on the Appearance tab, any custom colors specified here are lost.
- Click the **Bold**  button to specify the selected or subsequently typed text as bold.
- Click the **Italic**  button to specify the selected or subsequently typed text as italic.
- Click the **Underline**  button to specify the selected or subsequently typed text as underlined.
- Click the **Strikethrough**  button to selected or specify the subsequently typed text as stricken-through.
- Click the **Align Left** , **Align Center** , or **Align Right**  button to specify the how the selected or subsequently typed text is aligned.
- Click the **Paragraph Options**  button to specify the selected paragraph’s align-

ment, spacing and bullets or numbering in the **Paragraph Options** dialog.

- Specify the **Zoom** factor of the selected text by typing a percentage value in the text field or clicking the up/down arrows. This setting only affects the text as it appears in this dialog.

Note: Some fonts cannot be drawn at certain zoom factors. When this is the case, the appearance of the text will not change.

- 2 Type or paste text in the Text Entry field. See “Copy, Cut and Paste” on page 756.

Right-click in the Text Entry field to access a contextual menu from which you can select Cut, Copy, Paste and Select All. See “Contextual Menus” on page 30.

To edit text in the entry field, click and drag to highlight any portion of it and then use the tools on the Edit Bar as needed.

Paragraph Options Dialog

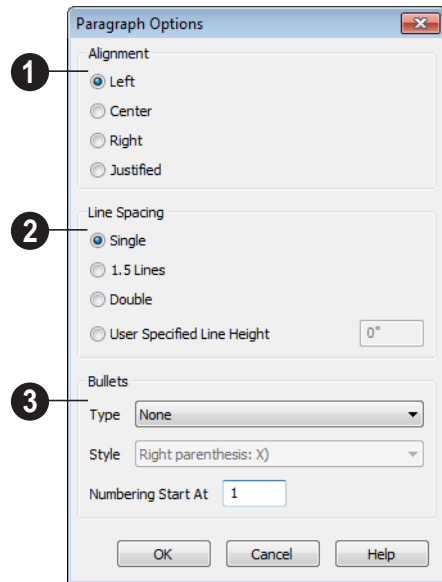



- 1 Specify the **Alignment** of the selected paragraph(s). See “Aligning Text” on page 756.
- 2 Specify the **Line Spacing** of the selected paragraph(s).
 - Click the radio button beside **Single**, **1.5 Lines**, **Double** or **User Specified**.
 - If you select **User Specified Line Height**, type the desired height for each line of text in the selected paragraph(s). For best results, this value should be at least as much as the largest character size used in the selected paragraph(s).
- 3 Specify the appearance of **Bullets** and numbering in the selected paragraph(s).
 - Select the desired bullet, numbered or lettered **Type** from the drop-down list.

- Select the desired punctuation **Style** for the selected numbered or lettered Type. Only available when a numbered or lettered Type is selected.
- **Numbering Start At** - Specify the number assigned to the first numbered or lettered paragraph in the selected text object. Value must be 1 or greater.

To adjust the size of bullets

1. Click at the end of a bulleted paragraph to position your cursor there.
2. Hold down the Shift key and press the right arrow key once to highlight the end of the paragraph.
3. Specify the desired bullet size in the text size field at the top of the Text tab.

Appearance Tab

Leader Lines  and **Text Lines with Arrows**  use the same default layer as Rich Text, so they share the same default

color, line weight and line style. See “Layers” on page 101.

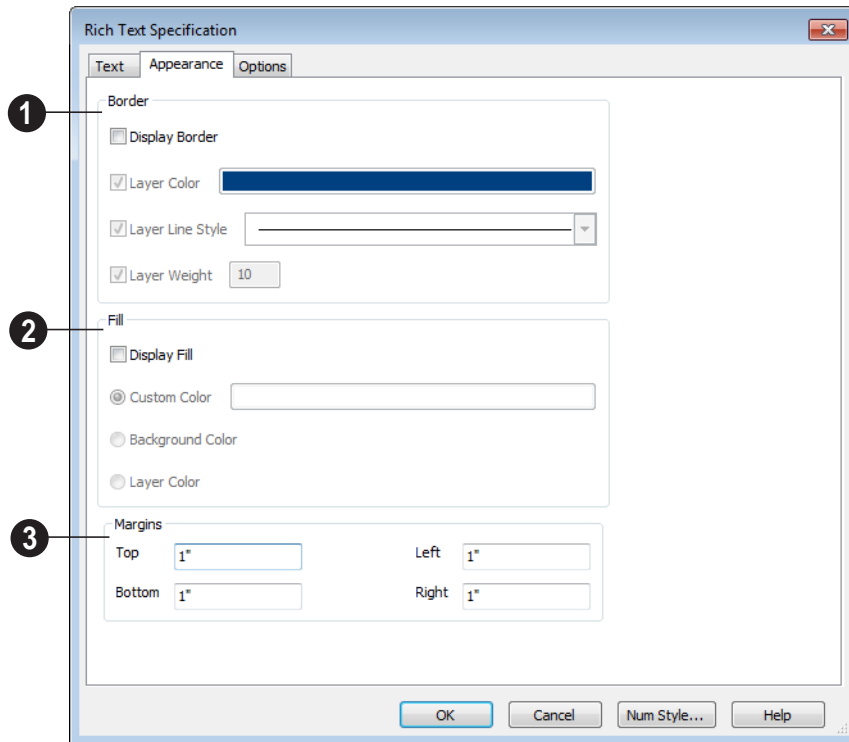

- 1 Specify the appearance of the text object's **Border**.

- Check **Display Border** to display a border around the selected text object and enable the settings that follow.
 - Check **Layer Color** to use the line color assigned to the text object's layer, or click the **Color** bar to select a different color. See "Color Chooser Dialog" on page 652.
 - Check **Use Layer Line Style** to use the line style assigned to the text object's layer, or choose another style either from the drop-down list.
 - Check **Use Layer Weight** to use the line weight assigned to the text object's layer, or specify a different weight. See "Line Weights" on page 849.
- 2 Specify the appearance of the text object's **Fill**.
- Check **Display Fill** to display a fill color within selected text object(s) and enable the settings that follow.
 - Select **Use Custom Color** then click the Color bar to use a fill color of your choosing. See "Color Chooser Dialog" on page 652.
 - Check **Use Background Color** to use program's Background color as the text object's fill color. See "Colors Panel" on page 63.
 - Check **Use Layer Color** to use the color assigned to the text object's layer as its fill color.
- 3 Specify the **Top, Bottom, Left and Right Margins**, the distance between the text and the border, of the selected text object(s).

Options Tab

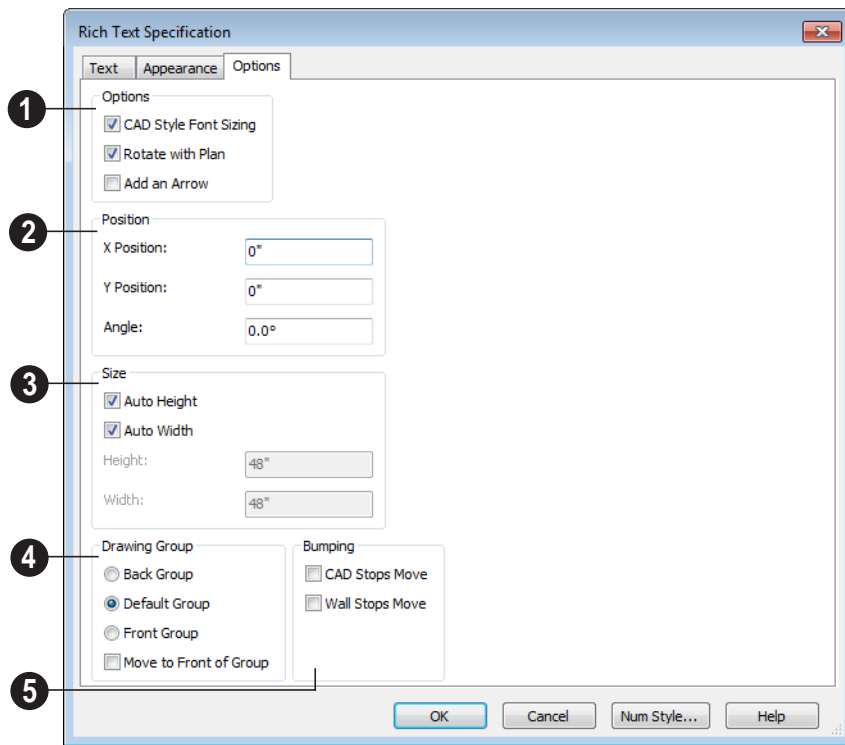

1 Options

- **CAD Style Font Sizing** measures text size based on the total height of the capital letter A, as most CAD programs do. Uncheck this to instead size text according to information stored with the font.
- Check **Rotate with Plan** to rotate the selected text when **Rotate Plan View**  is used. If unchecked, the selected text is unaffected when Rotate Plan View is used. See “Rotate Plan View” on page 163.

Rotate with Plan also affects text in views sent to layout if the layout box is rotated. See “CAD and Text in Layout” on page 868.

- Check **Add an Arrow** to add a Text Arrow to the selected text object. See “Text Arrows” on page 757.

2 Specify the Position of the selected text object using CAD coordinates.

The **X Position** and **Y Position** of the pointer can be set to display in the Status Bar, which may help determine the exact coordinates of a location in a plan or layout file. See “Appearance Panel” on page 61.

An exact **Angle** can be entered. An angle of 90 is vertical (pointing up) and an angle of 180 is upside down.

- 3 Specify the **Size** of the selected text object.
 - Check **Auto Height** to automatically adjust the text object's height to match its contents.
 - Check **Auto Width** to automatically adjust the text objects width to match its contents. When Auto Width is used, text extends in a single line rather than wrap.
 - Specify the **Height** of the selected text object(s).
 - Specify the **Width** to of the selected text object(s).
- 4 The **Drawing Group** options control how the selected object(s) display relative to other objects. See "Drawing Groups" on page 150.
 - Specify the **Back Group** to display the selected object(s) behind objects in the other two drawing groups.

- Specify the **Default Group** to display the selected object(s) in front of those in the Back Group but behind those in the Front Group.
- Specify the **Front Group** to display the selected object(s) in front of objects in the other two drawing groups.
- Check **Move to Front of Group** to display the selected object(s) in front of other objects in the same drawing group. This is an action rather than a state and is not available in the **Rich Text Defaults** dialog.
- 5 Specify the desired **Bumping** behaviors for the selected object(s). See "Bumping/Pushing" on page 152.
 - Check **CAD Stops Move** to bump the selected object into other CAD or CAD-based objects as it is moved.
 - Check **Wall Stops Move** to stop the selected object when it bumps into a wall.

Text Specification Dialog

The **Text Specification** dialog opens if you select a Room Label or a simple **Text** object in a legacy plan or layout file created in Version 8 or prior and click the **Open Object** edit button. See "Compatibility with Other Programs" on page 40.

Settings in the **Text Specification** dialog can also be found in other dialogs in the program, including the **Room Label Specification** and the **Dimension Defaults** dialogs.

Text Tab

Text Style Tab The Text Style tab is available for a variety of objects in the program and control the appearance of the

selected object's text. See "Text Style Tab" on page 766.

Editing Text

Once created, **Rich Text**  objects can be selected individually or as a group and edited using the edit handles, the edit toolbar buttons, and the **Rich Text Specification** dialog. See “Rich Text Specification Dialog” on page 747.



Text  objects can be selected and edited much the way Rich Text objects can; however, there are a few differences which are described here.

Editing Text Attributes

Most text attributes, including the font, size, style, and the content itself, are edited in the **Rich Text Specification** dialog.

In order to edit the attributes of an existing **Rich Text**  object, you must select some or all of the text before making changes. See “Text Tab” on page 747.

To edit Rich Text attributes

1. Select a **Rich Text**  object and click the **Open Object**  edit button.
2. On the Text tab of the **Rich Text Specification** dialog, click and drag to select some or all of the text typed into the Text field.

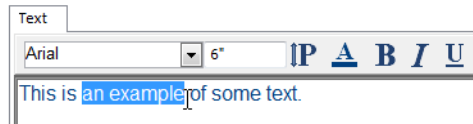

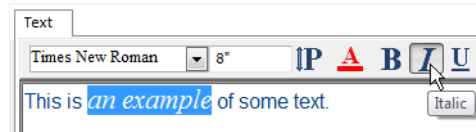

3. With some or all of the text selected, change any of the attributes available

along the top of the tab, including the font, size, color, and style.



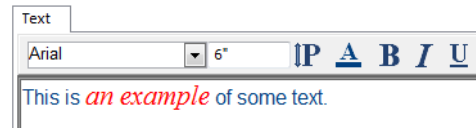

4. As changes are made, the selected text updates. Only the selected text is modified.



Text  objects do not support multiple fonts or other attributes in the same text object. When you choose an attribute, it is applied to all characters in the text object.

Using the Mouse

A selected **Rich Text**  or **Text**  object has the same edit handles as other box-based objects. See “Editing Box-Based Objects” on page 141.

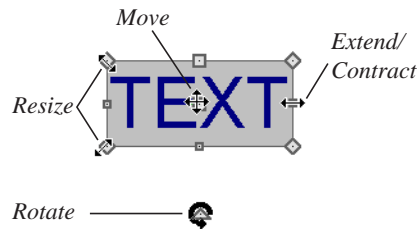





As a **Text**  box is made narrower or wider using an edit handle, the bottom of the text

box may expand or contract to allow all text to be shown.



As a **Rich Text**  box is made smaller using an edit handle, not all of the text may be visible.

Depending on the active **Edit Behavior** , the text box and the characters within it may or may not resize together when a corner edit handle is dragged. See “Edit Behaviors” on page 120.

- If **Resize**  editing is enabled, both the text object and the font resizes when a corner edit handle is dragged.
- If **Default**  or **Concentric**  editing is enabled, the text box resizes, but not the font size.
- If **Fillet**  editing is selected, the corners become rounded and the font size does not change. See “Behaviors Panel” on page 78.

 When text is resized using the edit handles, there is a “sticky point” at the natural size of the text box. Hold down the Ctrl key while resizing to override this behavior.

Using the Edit Tools

A selected **Rich Text**  or **Text**  object can be edited in a variety of ways using the buttons on the edit toolbar. See “The Edit Toolbar” on page 29.

Resizing Text

Both the border of a text object and the characters it contains can be resized.

The border of a text object can be resized using its edit handles or by specifying the Height and Width in its specification dialog.

The default character height of **Rich Text**  objects can be specified as can the character height for individual objects, in their specification dialogs. See “Text Defaults and Preferences” on page 744.

Character height can be measured in either of two ways. See “Character Size” on page 745.

Scaling Text

As with the size of other objects, text size is subject to the current drawing scale specified in the **Page Setup** dialog. See “Page Setup Dialog” on page 853.

To determine the **Height** needed to produce text of a certain printed size, click the **Print size**  button in the **Rich Text Specification** to open the **Printed Size Input** dialog.

To use the Printed Size Input dialog

1. Click the **Print Size**  button on the Text tab of the **Rich Text Specification** dialog.

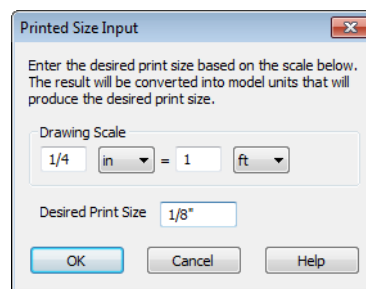





2. In the **Printed Size Input** dialog, confirm the desired Drawing Scale. Enter the **Desired Print Size** of the text.
3. Click OK to return to the **Text Specification** dialog. The **Height** updates, reflecting the character height necessary to print the text at the **Desired Print Size** when printed at the specified Drawing Scale.

In most cases, the **Drawing Scale** does not need to be changed in the **Printed Size Input** dialog unless you intend to send the current view to layout at a different drawing scale.

Aligning Text

Text can be aligned in a number of ways.

- The text content of a text object can be aligned to the left, right, center or justified in the **Rich Text Specification** dialog. See “Text Tab” on page 747.
- The text content of a text object can be also be aligned by clicking the **Align Left** , **Align Right** , **Center** , or **Justify**  edit button.
- The center points of text objects can be aligned with one another by assigning

them the same **X** and/or **Y Position**. See “Attributes Tab” on page 761.

- Text objects can be aligned by bumped them against a CAD line or CAD based object such as a roof plane. See “Bumping/Pushing” on page 152.

A variety of other alignment methods are also available. See “Aligning Objects” on page 154.

Copy, Cut and Paste

Copy, Cut and Paste of text into and out of the text specification dialogs can be accomplished using keyboard hotkeys:

- Press Ctrl + X to Cut the selected text and save it to the Windows clipboard.
- Press Ctrl + C to Copy the selected text and copy it to the Windows clipboard.
- Press Ctrl + V to paste your last cut or copied selection in a new text object.

For more, see “Copying and Pasting Objects” on page 114.

Copy, Cut and Paste use the Windows clipboard, making it possible to transfer text between text objects, between Home Designer Pro files, from a plan or layout into another application, or vice versa.

Copying & Pasting Text

The Copy, Cut and Paste commands use the Windows clipboard, making it possible to transfer text between text objects, between Home Designer Pro files, from a plan or layout into another application such as a text editor or spreadsheet program, or vice versa.

See “Copying and Pasting Objects” on page 114.

All or selected portions of the Materials List can also be copied and pasted into a text object, as well as into a word processing or spreadsheet program. See “Materials Lists” on page 887.

Cut, Copy, and Paste can also be accessed from the Edit menu of many applications, including Home Designer Pro. These menu commands are not available when the text specification dialogs are open, but you can use the associated hotkeys.

To Copy, Cut and Paste text

1. On the Text tab of either text specification dialog or in another program altogether, highlight the text you wish to cut, copy or paste.
2. Press Ctrl + X to **Cut** the selected text out of its original location and save it to the Windows clipboard.
3. Press Ctrl + C to **Copy** the selected text to the Windows clipboard without removing it from its original location.
4. Open the text object or a file in another application and click to place your cursor in the Text field, writing area, or spreadsheet cell.
5. Press Ctrl + V to **Paste** the copied text at the location of your cursor.



Bear in mind that when text is copied and pasted, its formatting is not always retained. The results depend on the program or type of

text object in which the content was created as well as the type of text object into which it is pasted.

Pasting into Rich Text



Text pasted into a **Rich Text** object from another source will retain most of its custom formatting.

Text pasted into a **Rich Text**  object from a spreadsheet program retains basic column and row information. Column width cannot be adjusted as it can in simple **Text** ; however, as you add or remove text from a cell, row height will increase or decrease to accommodate your changes.

The background colors of two or more cells copied from a spreadsheet application will be retained if pasted in to **Rich Text** ; however, once pasted background color cannot be edited.

If you want to retain the color of the actual text being pasted into a **Rich Text**  object, be sure to uncheck **Layer Color Text** in the **Rich Text Specification** dialog. See “Appearance Tab” on page 750.

Text Arrows

Text arrows, which are simply CAD lines with arrows drawn on the “Text” layer, can be used to connect text objects to details of interest in your drawing. See “Line Tools” on page 776.

Text arrows can be snapped together to form open or closed polylines. If two lines with arrows meet within the bounding box of a

text object, however, they will not join. This allows you to attach multiple, separate text arrows to a single text object. See “Editing Line Based Objects” on page 127.

Lines with arrows can be independent or attached to other objects. Arrows attach to closed polyline-based objects along their edges, but can attach to an architectural

object anywhere within its 2D symbol in floor plan view. If an arrow is attached to text or another object, deleting either the text or the object will also delete the arrow.

Text with Arrow

The **Text with Arrow** tool places a text object with an arrow already attached. This arrow can be selected and edited like any other arrow.

Text Line with Arrow





Text Lines with Arrow can be attached to text, CAD and architectural objects by selecting **CAD>**

Text> Text Line with Arrow  and then clicking and dragging to draw a line. There is no limit to the number of text lines with arrows that can be attached to an object.

The endpoints of **Text Lines with**

Arrows  can be joined to form polylines with corners that can be adjusted using the edit handles. See “Polylines” on page 790.

A **Text Line with Arrow**  behaves like a **Line With Arrow**  with one exception: Text Lines with Arrow are initially placed on the “Text” layer, not the “CAD, Default”. See “Layers” on page 101.

Auto Positioning Arrows

If either or both ends of a line with arrow are attached to a text object, **Auto Position Tail** and **Auto Position Head** are in the **Line Specification** dialog. See “Arrow Tab” on page 783.

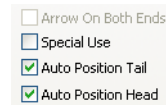

Check either or both if you want the text line with arrow to update its position on the text object if the text object or text line with arrow is moved.

- The first segment of a polyline arrow attached to text maintains its angle when Auto Position is off and text is moved.
- Auto Position is turned off automatically when an arrow is not attached to one of the auto position locations.
- Arcs and splines with arrows can also be attached to text objects.

There are four auto position locations on a text object: one at the midpoint of each side.

The following image illustrates the behavior of auto positioning. The arrow has the **Auto Position Tail** option checked. When the head of the line with arrow is moved, the tail of the arrow snaps to different auto position locations on the text object, maintaining its connection.

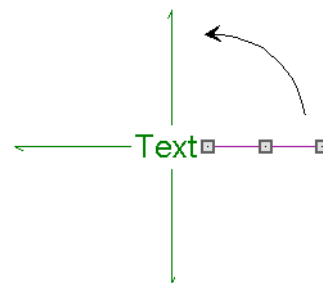

If a selected Text Line with Arrow is moved away from an auto position location and you

check **Auto Position Tail**, the tail will snap to the nearest auto position location.

Callouts

 Select **CAD> Text> Callout**, then click at the location where you want a callout to be placed in floor plan view, a cross section/elevation view or on a layout page. The **Callout Specification** dialog displays. Make any needed changes and click **OK** to place a callout. See “Callout Specification Dialog” on page 760.

Cross Section Lines

Check the **Cross Section Line** box in the **Callout Specification** dialog to add a cross section line perpendicular to the nearest wall. See “Callout Tab” on page 760.

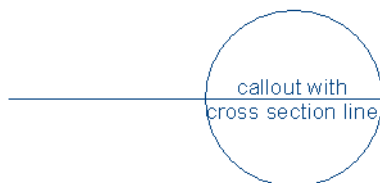

Cross section lines can be added to any callout shape. Resize or rotate the cross section line by dragging the triangular edit handle near the end of the cross section line.

Pointers and Arrows

To add an arrow or “hat” to a callout, select the callout and drag the diamond-shaped handle away from the center of the callout. An arrow is created, pointing in the direction you dragged.

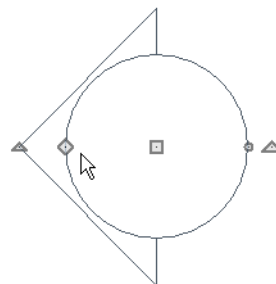

- Change the arrow’s direction by selecting the callout and dragging the edit handle appearing just beyond the arrow.
- Remove an arrow by clicking and dragging the edit handle at the point of the arrow towards the center of the callout.

You can also add as many lines with arrows as you like to callouts. To add an arrow to a callout, select **CAD> Text> Text Line with Arrow** , then click and drag to create a line with arrow, which can be moved or resized as needed.

Double Callouts

Any callout can be specified as a **Double Callout** in the **Callout Specification** dialog. See “Attributes Tab” on page 761.



To resize the line between the two callout shapes, select the callout and then click and drag the edit handle at the center of either

callout shape. The arrows on a double callout are always the same on both callouts.

Callout Specification Dialog



To open the **Callout Specification** dialog, select a callout and click the **Open Object** edit button. This dialog also displays when a new callout is created using the **Callout**  tool.

The **Callout Specification** dialog is similar to the **Callout Defaults** dialog but affects the selected callouts rather than all subsequently created callouts. See “Text Defaults and Preferences” on page 744.

Callout Tab

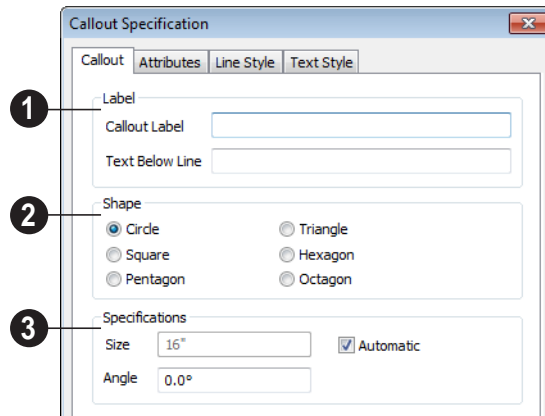

- 1** Specify the text of the selected callout's **Label** by typing in the text fields here.
 - Type a **Callout Label**, which displays inside the callout shape. If no **Text Below Line** is specified, the **Callout Label** is centered in the callout.
 - Type the **Text Below Line** for the bottom row, if desired. If **Text Below Line** is added, a line will separate it from the **Callout Label**.
- 2** Specify the **Callout Shape** by clicking the radio button beside one of the options here.
- 3** Additional **Specifications** can be set here.
 - Uncheck **Automatic** to enable the **Size** field and specify a new value. When checked, the callout is sized so that it encompasses the text of its label.
 - Specify the **Angle** of the selected callout.

Attributes Tab

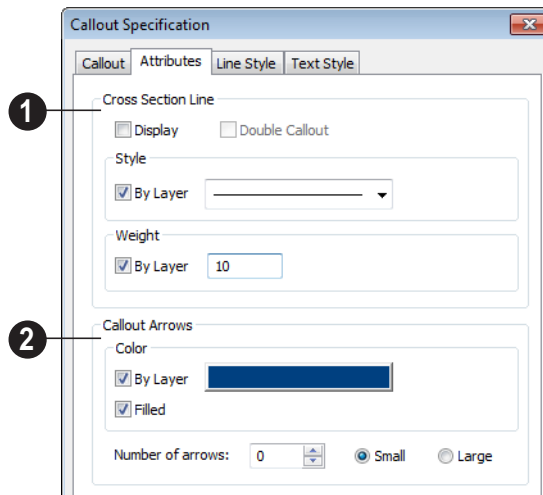

- 1 Specify the attributes of the selected callout's **Cross Section Line**.
 - Check **Display** to apply a cross section line to the selected callout. When unchecked, no cross section line is used.
 - Check **Double Callout** to specify two identical callouts connected by the cross section line. Only available when Display is checked.
 - Select the cross section line's line **Style** from the drop-down list. When **By Layer** is checked, the line style specified in the **Layer Display Options** dialog is used.
 - Specify the **Weight** of the cross section line or check **By Layer** to use the line weight specified in the **Layer Display Options** dialog.
- 2 Specify the attributes of the **Callout Arrows**.
 - Check **By Layer** to use the color specified in the **Layer Display Options** dialog

or click the **Color** bar to choose an arrow color. See “Color Chooser Dialog” on page 652.

- Check **Filled** to specify arrows with a solid fill. When unchecked, arrows are unfilled.
- Specify the **Number of arrows** and whether they are **Small** or **Large**.

Line Style Tab

The Line Style tab is found in the specification dialogs for many different objects. For more information, see “Line Style Tab” on page 781.

Additional attributes for the cross section line and arrows can be specified on the Attributes Tab.

Text StyleTab

The settings on this tab control the appearance of the selected object's text. For

more information, see “Text Style Tab” on page 766.

Editing Callouts

Callouts can be edited using the edit handles, the edit toolbar buttons and the **Callout Specification** dialog. See “Callout Specification Dialog” on page 760.

When a callout is selected, it has at least four edit handles. An additional rotate handle displays for each pointer added to the callout.

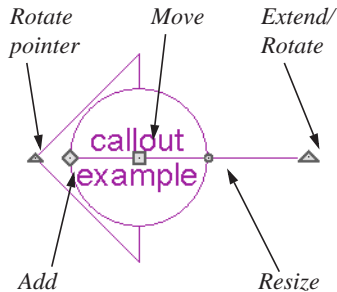

- The **Move** handle is located at the center of the callout and is used to move it.
- The triangular **Extend/Rotate** handle is used to extend and/or rotate the callout’s cross section line, if one exists. See “Cross Section Lines” on page 759.

- The small, square **Resize** handle is located on the edge of the callout and is used to resize it and its associated text.
- The **Add pointer** handle is used to add pointers by dragging away from the callout.
- The small triangular **Rotate pointer** handle located at the end of a pointer, if one has been added, is used to rotate that pointer.

Resizing Callouts

Callout shapes can be resized either in the **Callout Specification** dialog or using the edit handles. See “Callout Tab” on page 760.

Callout text can be resized in the **Callout Specification** dialog. See “Attributes Tab” on page 761.

As long as **Specify Callout Size** box is checked, a callout’s shape and text resize independent of one another. When this box is unchecked, the two are dynamically linked: if you resize the shape, the text adjusts accordingly or vice versa.

Markers



Markers for **Level Lines**, **Test Borings** and **Point Markers** can be placed in floor plan view, or cross sections. **Framing Reference Markers** should only be placed in floor plan views.

To create a marker, select **CAD > Text >**

Marker  and click at the location where you want it to be placed. The **Marker Specification** dialog opens.

You can also place a framing reference marker using **Build> Framing> Framing Reference** . See “Framing Reference Markers” on page 454.

Point Markers and Dimensions

When the **Point to Point Dimension**  tool is used to draw a dimension line and an object is not available to snap to at either the start or end point, a Point Marker will be

automatically created and the dimension line will locate it. See “Point to Point Dimensions” on page 730.

In addition, any dimensions drawn in a cross section/elevation view may locate Cross Section Lines that represent objects rather than the objects themselves. When this occurs, Point Markers will also be placed and the dimension lines will locate them. See “Cross Section Lines” on page 689.

Marker Specification Dialog

 To open the **Marker Specification** dialog, select a marker and click the **Open Object** edit button.

This dialog also displays when a new marker is created by clicking in floor plan view using the **Marker**  tool.

The **Marker Specification** dialog is similar to the **Marker Defaults** dialog but affects the selected markers rather than all subsequently created markers. See “Text Defaults and Preferences” on page 744.

Marker Tab

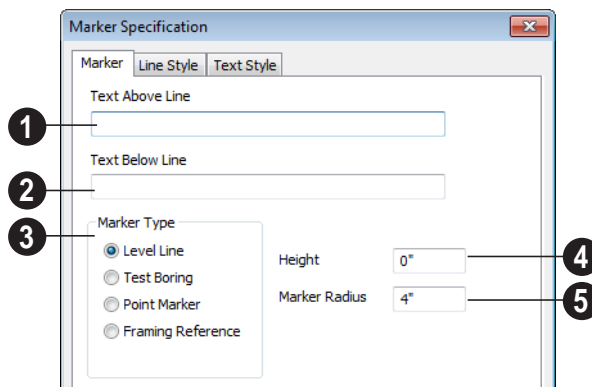

1 Enter optional **Text Above Line**.

2 Enter optional **Text Below Line** (Level Line Marker only).

- 3 Choose a **Marker Type**.

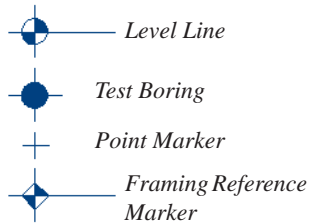

Only a **Framing Reference** marker effects the model. The other marker types are only cosmetically different.

- 4 Enter a number in the **Height** field. The height value will display with the marker symbol when a pound sign (#) is entered in the **Text Above** and/or **Below Line** fields.

- 5 Enter the **Marker Radius**, in inches or millimeters.

Line Style Tab

The Line Style tab is found in the specification dialogs for many different objects. For more information, see “Line Style Tab” on page 781.

Additional attributes for the cross section line and arrows can be specified on the Attributes Tab.

Text Style Tab

The settings on this tab control the appearance of the selected object’s text. For more information, see “Text Style Tab” on page 766.

Editing Markers

Markers can be edited using the edit handles, edit toolbar and **Marker Specification** dialog. See “Marker Specification Dialog” on page 763.

When a marker is selected, it has four edit handles.

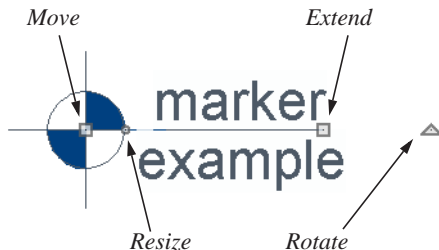

- The **Move** handle is located at the center of the marker and is used to move it.
- The **Resize** handle is located on the edge of the marker and is used to resize the marker and associated text.
- The triangular **Rotate** handle is used to rotate the marker and associated text.
- The **Extend** handle is used to adjust the distance between the marker and its associated text.

Text Styles

In Home Designer Pro, a Text Style is a set of attributes assigned to any object that displays text, such as Callouts, Markers, Dimensions, Plant Schedules, and object labels.

Note: Because of its ability to use multiple attributes in the same object, Rich Text does not use Text Styles. See “Rich Text Specification Dialog” on page 747.

You can create your own or edit existing Text Styles to suit your needs in the **Text Style Defaults** dialog

Text Style Defaults

Select **Edit > Default Settings**, click on “Text Styles” and click **Edit** to open the **Text Style Defaults** dialog. The **Saved Text Style Defaults** dialog will open, allowing you to select which Saved Text Style Defaults you would like to edit.

Saved Text Style Defaults Dialog

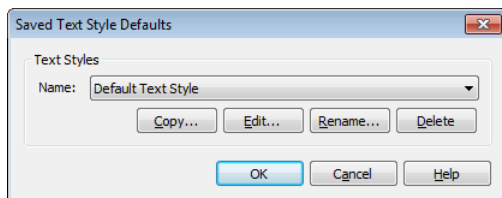

- Select the **Name** of one of them from the drop-down list. This is the currently selected Text Style.
- Click the **Copy** button to create a new Text Style by copying the one currently selected in the Name field.
- Click the **Edit** button to open the defaults dialog for the selected Text Style so that you can edit it.
- Click the **Rename** button to change the name of the currently selected Text Style.
- Click the **Delete** button to remove the currently selected Text Style from the current plan or layout file.
- Click **OK** to close the **Saved Text Style Defaults** dialog and save any changes you made in the defaults dialog.
- Click **Cancel** to close the **Saved Text Style Defaults** dialog without saving any changes that you may have made in the defaults dialog.

The settings in the **Text Style Defaults** dialog are similar to those on the Text Style tab of object specification dialogs throughout the program but affect all objects using that style rather than an individual selected object.

Text Style Tab

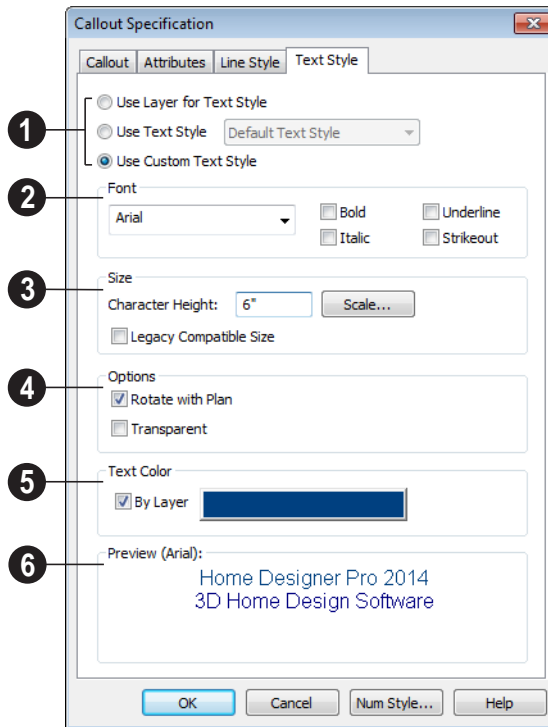

1 Specify where the selected object should draw its Text Style from. These options are not available in the **Text Style Defaults** dialog.

- Select **Use Layer for Text Style** to use the Text Style assigned to the layer that the selected text is located on.
- Select **Use Text Style**, then choose a style from the drop-down list to apply that style to the selected object, regardless of what layer it is on. When this is not selected, the name of the selected object's Text Style displays here for reference.

- Select **Use Custom Text Style** to enable the settings below and customize the selected object's Text Style attributes.

Check **Use Default Text Style** to use the default style for the selected object type, or uncheck this box to enable the settings below and define a custom style.

The settings that follow are only editable when **Use Custom Text Style** is selected. When it is not selected, information about the Text Style that is assigned to the selected object displays for reference.

- 2** Specify the attributes of the selected Text Style's **Font**.

- Select a font from the drop-down list.
 - The text styles **Bold**, **Underline**, **Italic**, and **Strikeout** are available. Check any of the boxes to apply that style.
- 3** Specify the **Size** of text using the selected Text Style.
- Enter the **Character Height** in drawing units. This height is subject to the current drawing scale. When imperial Inches or Feet and Inches are used, accuracy to 1/128" is possible.
 - Click the **Scale** button to open the **Printed Size Input** dialog. See “Scaling Text” on page 755.
 - In Version 9, text size was driven by dimension information associated with the font. Check **Legacy Compatible Size** to use this information for text sizing. See “Character Size” on page 745.
- 4** **Options** -
- Check **Rotate with Plan** to rotate text using the selected Text Style when **Rotate View**  is used. If unchecked, the text is unaffected when **Rotate View** is used. See “Rotate Plan View” on page 163.
- 5** **Rotate with Plan** also affects text in a view sent to layout if the layout box is rotated. See “CAD and Text in Layout” on page 868.
- Check **Transparent** to make text boxes using the selected Text Style transparent. When unchecked, text boxes have a solid fill the same color as your background color. See “Colors Panel” on page 63.
- 5** Specify the selected Text Style’s **Text Color**. When Use Custom Text Style is not selected above, a Text Color does not display here for reference.
- When **By Layer** is checked, text uses the line color assigned to the layer that the object it is assigned to is located on. See “Displaying Objects” on page 102.
 - Uncheck **By Layer**, then click the **Color** bar to select a different color. See “Color Chooser Dialog” on page 652.
- 6** A preview of the Text Style currently assigned to the selected object displays here.

CAD Objects

With the 2D Computer Aided Design (CAD) tools included in Home Designer Pro, you can add details to views of your 3D model to create complete working drawings.

The CAD Tools are used to add information to 2D views of your model. CAD objects do not affect 3D objects or display in camera views or overviews, but they can be used to add details to layout pages, floor plan view and cross section/elevation views.

CAD polylines can be converted to 3D objects such as countertops and terrain data, and shown in 3D views. See “Convert Polyline” on page 165.

CAD objects are edited much like other objects in Home Designer Pro. See “Editing Objects” on page 119.

Chapter Contents

- CAD Defaults and Preferences
- The CAD Drawing Tools
- Point Tools
- Line Tools
- Line Specification Dialog
- Arc Tools
- Drawing Arcs - Arc Creation Modes
- Arc Specification Dialog
- Circle Tools
- CAD Circle/Oval/Ellipse Specification Dialog
- Polylines
- Polyline Specification Dialog
- Box Tools
- Box Specification Dialog
- Splines
- Displaying CAD Objects

CAD Defaults and Preferences

 CAD Defaults can be accessed by selecting **Edit> Default Settings** from the menu and expanding the CAD category.

 The behavior and appearance of CAD objects are also affected by settings on the CAD, Line Properties, Sun Angle,

Behaviors, and Snap Properties Panels of the **Preferences** dialog. Unlike default settings, preference settings are global, affecting all plan and layout files. See “Preferences Dialog” on page 60.

CAD Defaults Dialog

 The settings in the **CAD Defaults** dialog control the basic appearance of CAD objects. To open this dialog, select **Edit> Default Settings** from the menu and expanding the CAD category. It can also be opened by clicking the **CAD Defaults** button, which can be added to a toolbar. See “To add a button to a toolbar” on page 94.

Each plan file has multiple **CAD Defaults** dialogs: one affecting floor plan view and one for every cross section/elevation view. Layout files each have their own CAD defaults, as well. Each dialog can be accessed by opening the **CAD Defaults** dialog from within that view.

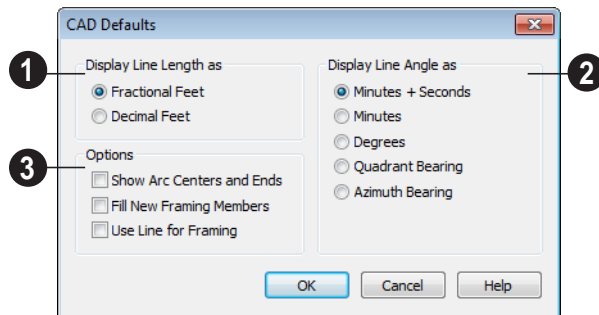

1 Specify whether to **Display Line Length** as either **Fractional** or **Decimal Feet**. This controls the appearance of line length indicators, which only display when **Show Length** is checked in an object’s

specification dialog. See “Line Style Tab” on page 781.

2 **Display Line Angles as** - Specify the format to use when **Show Angle** is checked in an object’s specification dialog. See “Line Style Tab” on page 781.

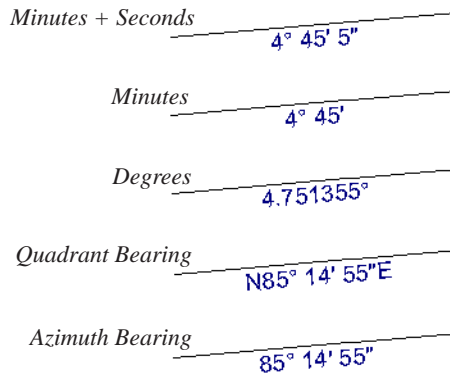

Line angles can be displayed using three basic methods:

- **Degrees/Minutes/Bearings** - Measured counterclockwise from a line drawn horizontally to the right of the angle's vertex. Useful for most drawing tasks. Select the level of accuracy that you require.
- **Quadrant Bearings** - Measured from a vertical line representing North/ South, Quadrant Bearings use directional bearings in their measurements. Useful for site drawings.
- **Azimuth Bearings** - Measured from a line drawn straight up from the angle's vertex (ie, North on a site plan). Useful for site drawings, Azimuth Bearings use degrees, minutes, and seconds in their measurements.



Line length and angle indicators use the Text Style of the layer that their object is on. See "Text Styles" on page 765.

3 Select any combination of the available Options.

- Check **Show Arc Centers and Ends**  to show arc centers and ends. Ends display as small lines where arcs connect to one another. Centers also acts as snap points. See "Show Arc Centers" on page 134.

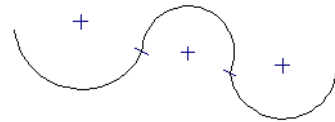

Show Arc Centers and Ends

- Check **Fill New Framing Members** to draw all new framing members with a solid white fill. This settings is not view specific - it affects all new framing members, regardless of the floor they are drawn on.
- Check **Use Line for Framing** to show all framing members as single lines rather than as closed polylines in floor plan view. See "Displaying Framing" on page 458.

The CAD Drawing Tools







The CAD Tools are available in the CAD menu, and also in the CAD toolbar configuration, which can be accessed by clicking the **CAD Configuration** button. See "Toolbar Configurations" on page 98.

Point Tools







Select **CAD> Points** to access the Point Tools.

The **Place Point** , **Input Point** , **Point Marker** , and **Delete Temporary Points**  tools can be used to create or remove snap points for a variety of purposes. See “Point Tools” on page 772.



Line Tools

 Select **CAD> Line** to access the Line Tools.

The **Draw Line** , **Input Line** , **Line With Arrow** , **Sun Angle** , and the **North Pointer**  allow you to create various types of lines. See “Line Tools” on page 776.





Arc Tools

 Select **CAD > Arcs** to access the Arc Tools.

The **Draw Arc** , **Input Arc** , and the **Arc With Arrow**  tools allow you to create arcs. See “Arc Tools” on page 785.





Box Tools

 Choose **CAD > Boxes** to access the Box Tools.

The **Rectangular Polyline** , **Box** , **Cross Box** , and **Insulation**  tools allow you to create a variety of polyline and box objects. See “Box Tools” on page 794.

Circle Tools

 Select **CAD> Circles** to access the Circle Tools.

The **Circle** , **Circle About Center** , **Oval** , and the **Ellipse**  tools are discussed in detail later in this chapter. See “Circle Tools” on page 788.

Splines

 A Spline is a curve that passes smoothly through a set of points. Select **CAD> CAD> Draw Spline** to draw connected line segments that form a spline. See “Splines” on page 796.

Once created, a spline can be selected and edited. See “Editing Spline Based Objects” on page 144 and “Polyline Specification Dialog” on page 791.

Dimension Tools

 Select **CAD> Dimensions** to access the Dimension Tools. The **Dimension Tools** can be used with CAD and architectural objects and are discussed in their own chapter. See “Dimensions” on page 719.





Text Tools

 Select **CAD> Text** to access the Text Tools. The Text Tools are discussed in their own chapter. See “Text, Callouts & Markers” on page 743.

Point Tools

 Select **CAD> Points** to access the

Point Tools.

Temporary points created using the **Place Point**  and **Input Point**  tools and permanent **Point Markers**  can be used with **Object Snaps**  to accurately position a variety of objects. See “Object Snaps” on page 110.

Place Point

 Select **CAD> Points> Place Point**, then and click in the drawing area to place a temporary CAD point at that location.

Input Point

 Temporary CAD points can be placed with precision by entering coordinates. See “3D Drafting” on page 25.

To use the Input Point tool

1. Select **CAD> Points> Input Point**  to open the **New CAD Point** dialog.
2. Select a **Location** option, and enter the desired location of the point.
3. Click **OK** to close the dialog and create the new point. The new point becomes the Current Point and is highlighted. See “The Current Point” on page 774.
4. Alternatively, click **Next** to create the new point but remain in the **New CAD Point** dialog and create additional points. As each is created, it becomes the Current Point.

New CAD Point Dialog

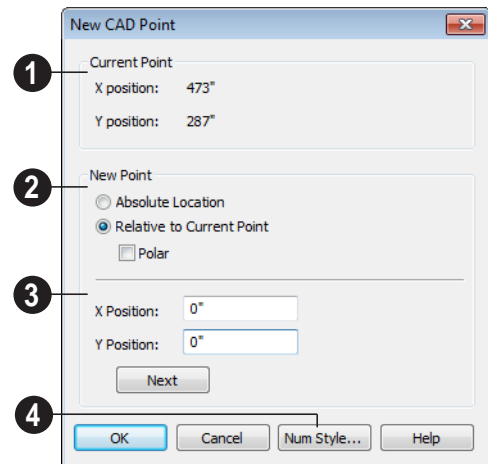



- 1 The location of the **Current Point** displays here. If no CAD points are present, the origin (0, 0) displays. See “The Current Point” on page 774.
- 2 Begin by specifying how you want to define the location of the **New Point**.
 - **Absolute Location** - Define the point in **X Position** (horizontal) and **Y Position** (vertical) coordinates, relative to (0,0).
 - **Relative to Current Point** - Define the new point in **X** and **Y** coordinates that are relative to the Current Point, as though that point was at (0,0). Only available when a Current Point exists.
 - Check **Polar** to define the new point by its **Distance** and **Angle** from the Current Point rather than in X and Y coordinates. This is helpful when creating a plot plan. See “Plot Plans” on page 553.
- 3 The position of the New Point is defined here. The options available depend on the method chosen to define it.

- **X Position** and **Y Position** coordinates relative to (0,0) are entered if the Absolute Location method is specified.
- **X Position** and **Y Position** coordinates relative to the Current Point are entered if the Relative to Current Point method is specified.
- **Distance** and **Angle** from the Current Point are entered if the Relative to Current Point: Polar method is specified.
- Click **Next** to create the new point without exiting the dialog so you can input data for the next point. The newly created point becomes the Current Point.

4 Click **Num Style** to change the units shown in the **New CAD Point** dialog. See “Number Style/Angle Style Dialog” on page 89.

Point Markers

 Use a permanent **Point Marker** as a snap point for dimension lines and other CAD objects. Select **CAD> Points> Point Marker** and click in the view to place a permanent point marker. Point markers display as a simple cross, with or without a text label. They can be opened for specification and modified to include a label or alter their attributes.

You can also place Point Markers using the **Marker**  tool, which lets you specify the marker label and type. See “Markers” on page 762.

Point Markers are also created when the **Point to Point Dimension**  tool is used.

See “Point to Point Dimensions” on page 730.

Delete Temporary Points

 All temporary points can be deleted at once using **CAD> Points> Delete Temporary Points**.

You can also press the **Delete** key when nothing is selected to delete the points one by one; however, **Delete Temporary Points**  can save time when there are many points.

The Current Point

In any plan view, there may be multiple temporary CAD points created by the user and/or the program. The Current Point is either the most recently created or the most recently accessed temporary CAD point and is used for a variety of functions, such as:

- As an anchor for snapping objects to a precise location.
- As the starting point for objects as they are drawn by entering data. See “Entering Coordinates” on page 113.
- As the point about which objects are rotated. See “Rotating Objects” on page 161.
- To indicate the points at which roof planes can join. See “To find roof plane intersection points” on page 367.

When multiple temporary points are on-screen, the current CAD point is highlighted so it can be easily identified.

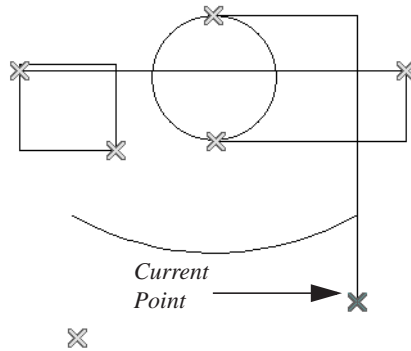

There can only be one Current Point

To delete the Current Point

1. Make sure no other objects are selected by clicking the **Select Objects**  button. You can also press the Esc key to deselect any selected objects.
2. Press the Delete key on the keyboard to delete the Current Point. The temporary point created prior to this one becomes the new Current Point.
3. If you continue pressing the Delete key, temporary points will be deleted in the reverse order that they were created.

Move Point Dialog

The Current Point can be repositioned relative to itself, another point, or a CAD object such as a line using the **Move Point** dialog.

For example, you can locate the point exactly one-quarter the distance along a given line, or exactly 6 inches from one end. This new location can then be used for the start point of a new line or other purpose.

To reposition a temporary point, double-click the point you want to move using the **Select Objects**  tool. Doing so makes that point the Current Point and also opens the **Move Point** dialog.

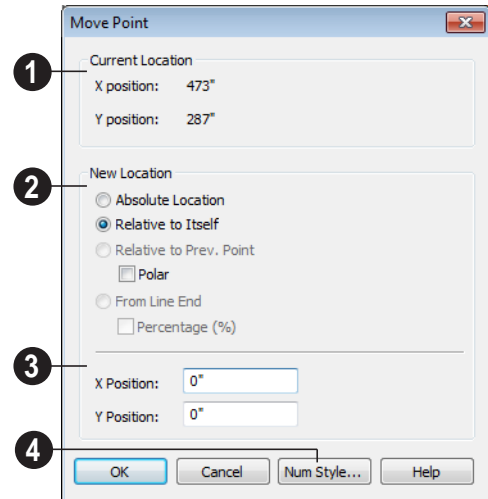

- 1 The **Current Location** of the selected point displays here for reference.
- 2 Begin by specifying how you want to define the **New Location** of the point.
 - **Absolute Location** - Define the new location in **X** (horizontal) and **Y** (vertical) coordinates, relative to (0,0).
 - **Relative to Itself** - Define the new location in **X Position** and **Y Position** coordinates relative to the current location, as though that point was at (0,0).
 - **Relative to Prev. Point** - Define the new location relative to the point that was the Current Point prior to this one, as though that point was at (0,0).

Check **Polar** to define the new location's

Distance and **Angle** from the previous point instead of using X and Y coordinates.

- **From Line End** - Define the new location along the edge of a nearby CAD object. This option is enabled only when the point is located on a CAD object and refers to the edge nearest to the point's original location. When selected, the **Along Line** field becomes available, below.

Check **Percentage (%)** to specify the **Along Line** value as a percentage of the total line or arc length rather than as a distance. 0% moves the point to the closest end of the nearest edge, 50% to the midpoint, and 100% to the other end. Negative numbers and percentages greater than 100 are allowed.

If the point is near an arc, **Along Line** is measured along the curve.

If the point is near a box or polyline, **Along Line** is measured along the nearest side just as it does with an individual line or arc.

If the point is near an oval or circle, **Along Line** is measured along an (invisible) axis line that the item was originally drawn along.

3 Specify the new position of the point here. The information used to define it depends on the method chosen to define the **New Location**.

- **X Position** and **Y Position** coordinates are entered if the **Absolute Location** method is specified or if either **Relative** method is used with **Polar** unchecked.
- **Distance** and **Angle** are entered if either **Relative** method is specified when **Polar** is checked.
- **Along Line** - When the **From Line End** method is used, specify the distance from the new location of the point along the nearest edge of the CAD object to the end it was originally closest to. When **Percentage (%)** is checked, enter this value as a percentage instead.

4 Click **Num Style** to change the units shown in the **New CAD Point** dialog. See "Number Style/Angle Style Dialog" on page 89.

Line Tools



Select **CAD> Draw Lines** to display the Line Tools.

If **Object Snaps**  is enabled and **Edit**

Object Parts  is disabled, you can connect the ends of two lines and/or arcs to form a single entity called a polyline. See "Polylines" on page 790.

Draw Line



Select **CAD> Lines> Draw Line**, then click and drag from beginning to end.





If you double-click the **Draw Line** tool, the **Input Line** dialog will open.

Input Line

 CAD lines can also be created using absolute values entered with the keyboard by selecting **CAD> Lines> Input Line**. This method is slower but more precise than using the mouse and is ideal when the desired length and angle of each line is known, such as with property lines.

Before any line is drawn using this method, a starting point must be defined. If a starting point has not been defined, Home Designer Pro assumes a starting point of 0,0.

To use the Input Line tool

1. Select **CAD> Points> Place Point** , then click the screen to place a CAD point. This is the Current Point, and is the start point for the new line. See “The Current Point” on page 774.
2. Select **CAD> Lines> Input Line**  to open the **New CAD Line** dialog.
The **New CAD Line** dialog can also be opened by double-clicking the **Line Tools**  parent button.
3. If necessary, specify the start point.
4. Specify the method used to define the location of the End Point.
5. Click **OK** to close the dialog and draw the line, or click **Next** to draw the line but remain in the **New CAD Line** dialog and draw additional lines.

Note: If you accidentally click OK instead of Next and need to continue drawing a polyline using the New CAD Line dialog, select the Input Line tool again and continue.

New CAD Line Dialog

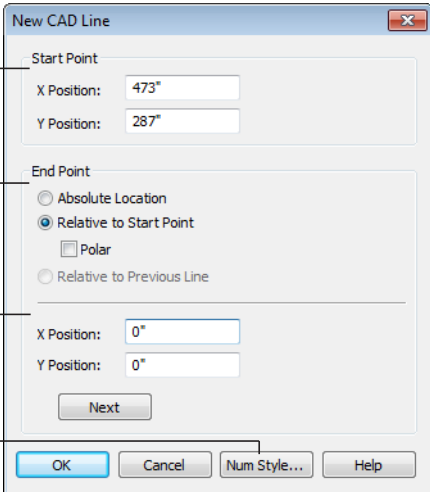

- 1 The **X Position** (horizontal) and **Y Position** (vertical) coordinates of the start point for the new line display here. They can also be changed, if you wish.
- 2 Begin by specifying how you want to define the line **End Point Location**.
 - **Absolute Location** - Define the end point of the new line in **X Position** (horizontal) and **Y Position** (vertical) coordinates, relative to (0,0).
 - **Relative to Start Point** - Define the end point of the new line in **X** and **Y** coordinates that are relative to the line’s Start Point, as though it were at (0,0).
 - Check **Polar** to define the End Point of the new line by its **Distance** and **Angle** from the Start Point rather than in X and Y coordinates. This is helpful when creating a plot plan. See “Plot Plans” on page 553.
 - **Relative to Previous Line** - Define the End Point of the new line by its **Distance**

and **Angle** relative to the end of the last line drawn, as though that line's angle were at 0° and its End Point, at (0,0).

- 3 The new line's **End Point** is defined here. The information used to define it depends on the method chosen to define the End Point Location.
 - **X Position** (horizontal) and **Y Position** (vertical) coordinates relative to (0,0) are entered if the Absolute Location method is specified.
 - **X Position** (horizontal) and **Y Position** (vertical) coordinates relative to the start point are entered if the Relative to Start Point method is specified.
 - **Distance** and **Angle** from the start point are entered if the Relative to Start Point: Polar method is specified.
 - **Distance** and **Angle** from the start point are entered if the Relative to Previous Line method is specified.
 - Click **Next** to create the line without exiting the dialog so you can input data for the next line. The start point of the next line is the end point of this line.
- 4 Click **Num Style** to change the units shown in this and other dialogs. See "Number Style/Angle Style Dialog" on page 89.

Enter Coordinates

Similar to **Input Line**, lines can also be specified by pressing the Tab key on the keyboard when a line is in the process of being drawn. This opens the **Enter Coordinates** dialog. See "Entering Coordinates" on page 113.

Line With Arrow



Create a line or polyline with an arrow on one or both ends by selecting **CAD> Lines> Line With Arrow**, then clicking and dragging on screen. The initial attributes of the line's arrow are set in the **Arrow Defaults** dialog. See "Arrow Defaults" on page 744.

As with lines, lines with arrows can be connected to form polylines and can be edited after they are created. See "Editing Line Based Objects" on page 127 and "Line Specification Dialog" on page 780.

You can also create arcs with arrowheads. See "Arc with Arrow" on page 786.

If a line or arc with arrow is snapped to another object such as text and that object is deleted, the line or arc with arrow will be deleted, as well.

North Pointer



The **North Pointer** defines the direction of true north in a plan. The direction of north does not affect the orientation of the Snap and Reference grids, but it does determine the direction of bearing information as well as how shadows and conditioned area totals are calculated.

If a **North Pointer**  is not used, north is assumed to be straight up on screen in floor plan view.



Every bearing is defined relative to North, so establish this direction before entering survey information for plot layout or for bearings to establish polar direction for the creation or editing of objects such as points, lines, arcs, etc.

Select **CAD> North Pointer** , then click and drag to draw the pointer, starting at the tail and dragging toward the point. Once it is drawn, you can define its exact length and angle in the **Line Specification** dialog. See “Line Specification Dialog” on page 780.

When a North Pointer is placed on one floor of a plan, a North Pointer drawn on any other floor automatically points in the same direction. If the direction of the North Pointer is reset on any floor, those on all other floors automatically reset, as well.

To enter the angle in bearings

1. First, type *N* or *S* (for North or South).
2. Next, type the degrees (followed by *d*), then the minutes (followed by *'*), then the seconds (followed by *"*).
3. Finally, type either *E* or *W* (for East or West).

If minutes are zero, you do not need to enter a value. Following are some examples of bearings. It is not necessary to capitalize the letters. Spaces are also optional.

- N 20d 30' E
- S 45' W
- N 89d 48' 30" W
- N 90' E

If you choose to display line angles when a North Pointer exists, be sure to select the appropriate format in the **CAD Defaults** dialog. See “CAD Defaults and Preferences” on page 770.

- If angles are set to **Bearings**, they are relative to the North Pointer.

- If angles are set to show as **Degrees**, the angle relates to 0 degrees (horizontal to the right) even if a North Pointer is present.

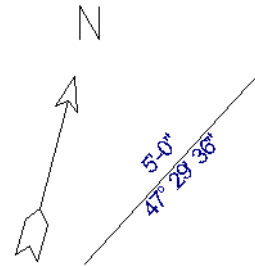

Line angle shown in degrees. This does not reference the North Pointer.

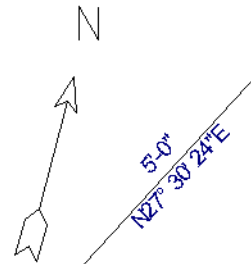

The same line angle is set to show Bearings. This shows the angle in reference to the North Pointer.

North Pointers can be selected and edited using their edit handles and the edit toolbar buttons. All attributes of the N aside from its size are drawn from the Text Style assigned to the “CAD, Default” layer. For more information, see “Editing Line Based Objects” on page 127.

Sun Angle



In floor plan view, you can create multiple **Sun Angles**. Select **CAD>**

Lines > Sun Angle, then click in floor plan view. For each Sun Angle you place, specify time of year, time of day, and a location based on longitude and latitude.

Sun Angles affect the angle of the Default Sun Light. If a North Pointer is present, the

Sun Angle will be accurate relative to it. See “Sun Angles” on page 701.

Sun Angles can be moved and extended using the edit handles, but cannot be rotated.

Line Specification Dialog



Select a CAD Line, Line With Arrow, or Text Line With Arrow and click the **Open Object** edit button to open the **Line Specification** dialog.

The settings on the Line, Line Style, and Arrow tabs in this dialog are found in the specification dialogs for a variety of different objects in the program.

Line Tab

The information on the Line tab of the **Line Specification** dialog is similar to that found

on the Selected Line tabs of various specification dialogs in the program.

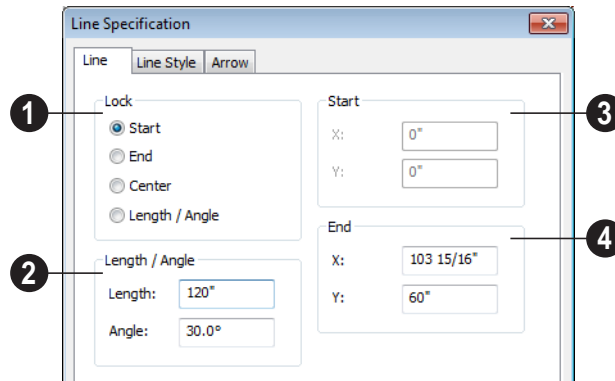

1 Lock - These lock options control how changing properties on this dialog affect the line.

Start - Select this option to keep the start of the line fixed when changing the length, angle, and end.

End - Select this option to keep the end of the line fixed when changing the length, angle, and start.

Center - Select this option to keep the center of the line fixed. Changing the length of the line moves the start and end of the line equally. Changing the angle rotates the line around the center.

Select **Length/Angle** to keep the length and angle of the line segment fixed. Moving the start or end moves the other end so the length and angle of the line do not change.

- Specify the **Length** and **Angle** of the selected line.

- Specify the X and Y coordinate for the **Start** of the line.

- Specify the X and Y coordinate for the **End** of the line.

The format used here can be changed by clicking the **Num Style** button. See “Number Style/Angle Style Dialog” on page 89.

Line Style Tab

The Line Style tab is found in the specification dialogs for many different objects. Here you can control the display of a

CAD line(s) and/or arc(s) that make up an object.

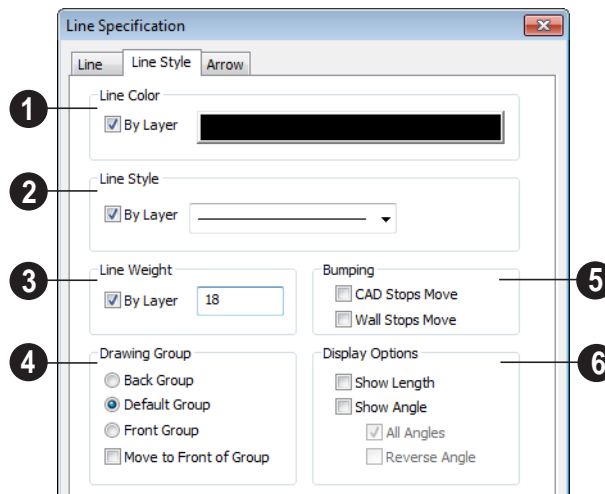

- Specify the **Line Color** used to show the selected object.
 - Check **By Layer** to use the line color assigned to this layer.
 - Click the color bar to assign a line color to the selected object(s). See “Color Chooser Dialog” on page 652.
- Specify the **Line Style** used to show the selected object.

- Check **By Layer** to use the line style assigned to this layer.
- Click the drop-down list to select from all available line styles. You can use the keyboard arrow keys to scroll up and down through the options.

- Define the **Line Weight** (in pixels).

Check **By Layer** to use the **Line Weight** assigned to the specified layer.



Setting the line weight to zero (0) makes the line weight print as thin as possible.

4 The **Drawing Group** options control how the selected object(s) display relative to other objects. Not available for Walkthrough Paths. See “Drawing Groups” on page 150.

- Select **Back Group** to display the selected object(s) behind objects in the other two drawing groups.
- Select **Default Group** to display the selected object(s) in front of those in the Back Group but behind those in the Front Group.
- Select **Front Group** to display the selected object(s) in front of objects in the other two groups.
- Check **Move to Front of Group** to display the selected object(s) in front of other objects in the same drawing group.

You can also move a selected object to the front of its drawing group by clicking the **Move to Front of Group**  edit button. See “Move to Front of Group” on page 151.

Note: “Move to Front of Group” is an action, not an attribute. The box is not checked the next time the specification dialog is opened.

5 Specify the desired **Bumping** behaviors for the selected object(s).

- Check **CAD Stops Move** to bump the selected object into other CAD or CAD-based objects as it is moved, and/or to push the other object(s).
- Check **Wall Stops Move** to stop the selected object when it bumps into a wall. Walls cannot be pushed by other objects.

CAD Stops Move and **Wall Stops Move** only function when **Bumping/Pushing** is enabled. See “Bumping/Pushing” on page 152.

6 Select the desired **Display Options**. These options not available for CAD Box- or CAD Circle-based objects, or for North Pointers or Sun Angles.

- Check **Show Length** to show the length of each line centered above the line. This option is available with line and arc segments and is commonly used for property lines. The length format for Imperial units (fractional or decimal feet) is defined in the **CAD Defaults** dialog. See “CAD Defaults Dialog” on page 770.
- Check **Show Angle** to show the angle of each line centered below the line and enable the two options that follow. The angle format (degrees or bearings) is defined in the **CAD Defaults** dialog.
- Uncheck **All Angles** to show only those angles that are neither horizontal nor vertical. This is automatically checked when **Show Angle** is checked.
- Check **Reverse Angle** to reverse the angle by 180°. This may be helpful when showing a line’s bearing, since the direction a line is drawn from start point to end point defines its bearing.

Arrow Tab

The Arrow Tab is available for any line, arc, open polyline, or spline that can have an arrow.

Closed polylines, Sprinkler Lines and Electrical connections are examples of objects that cannot have arrows.

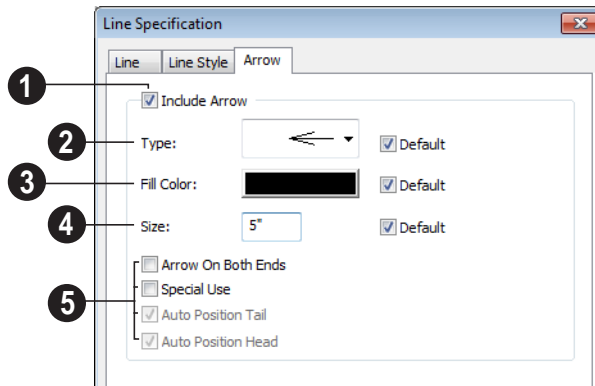

- 1 Check **Include Arrow** to turn the arrows on or off.
- 2 Select an arrowhead **Type** from the drop-down list.

If multiple arrows are selected, and they have more than one arrowhead type, check **No Change** to keep the defined arrow type for each arrow.

Check **Default** to set the arrow type to the default specified on the Arrow tab of the **Text Defaults** dialog. See “Text Defaults and Preferences” on page 744.

- 3 Select the **Fill Color** used to fill the arrowheads.

If multiple arrows are selected and they have more than one fill color, check **No Change** to keep the defined Fill Color for each arrow.

Check **Default** to use the default fill color.

- 4 Define a **Size** for the arrow(s).
Check **Default** to use the default size.
- 5 Select from the available **Options**.

Check **Arrow on Both Ends** to place a head on both ends of the selected arrow(s).

Auto Position Tail and **Auto Position Head** are available when either end of the line is attached to a text object. Check either or both options if you want this text line with arrow to update its position on the text object if the text object or text line with arrow is moved. See “Auto Positioning Arrows” on page 758.

Drawing Arcs - Arc Creation Modes



There are two Arc Creation Modes that control how arcs and arc-based objects are drawn. Select **Edit> Arc Creation Modes** to select a mode.

The program remembers the last creation mode used between sessions. Once drawn, all arcs are edited similarly. See “Editing Arc Based Objects” on page 130.

Before deciding which Arc Tool or Arc Creation Mode is best for the project at hand, it is helpful to be familiar with the different components that make up an arc.

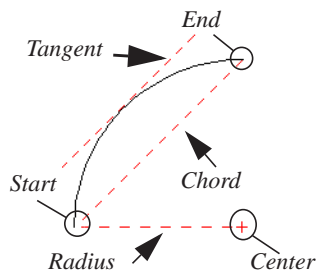

- The **center** of an arc is the point the arc is drawn about.
- The **radius** is the distance from the center to the arc.
- The **start** is where the arc begins.
- The **end** is where the arc stops.
- The **chord** is the straight line between the start and end point.
- A straight line that intersects an arc and is perpendicular to the radius of the arc at that point is **tangent** to the arc.

Free Form Arc



Free Form Arc mode allows you to define an arc by clicking and dragging along the desired path. There are two methods for using this mode.

To draw a Free Form arc

1. Select **CAD> Arcs> Draw Arc** , then click at the arc's start point.
2. Move the pointer along the desired curve while dragging to curve the arc.
3. Release the mouse button at the end point to complete the arc.

Arc About Center



Arc About Center mode allows you to draw an arc by defining the center and then the start and end points.

To draw an Arc About Center

1. Select **CAD> Arcs> Draw Arc** , then click once to define the center point.
2. Click and drag from the start point of the arc to its end point.
3. Or, click and drag an arc. The Current Point is used as the center. See “The Current Point” on page 774.

Arc Tools

 Select **CAD> Arcs** to display the submenu of Arc Tools.



Draw Arc

 The method used to draw an arc using **Draw Arc** depends on which Arc Creation Mode is currently active. Once drawn, an arc can be edited. See “Editing Arc Based Objects” on page 130.

Input Arc

 An arc can be drawn to exact specifications using the **New CAD Arc** dialog.

To use the Input Arc feature

1. Define a start point by clicking the screen using the **Place Point**  tool. The “X” defines the current point, which is the start point for the new arc.
2. With the start point defined, select **CAD> Arcs> Input Arc**  to open the **New CAD Arc** dialog. Define the arc endpoint, curvature, and direction.

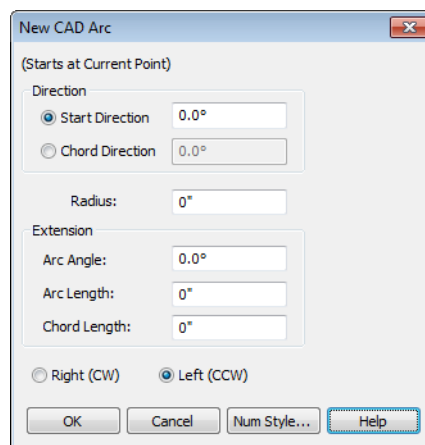

3. Select either the **Start Direction** or the **Chord Direction**.
 - The **Start Direction** defines the angle of the tangent from the arc’s start point.
 - The **Chord Direction** defines the angle of the arc’s chord from the start point.

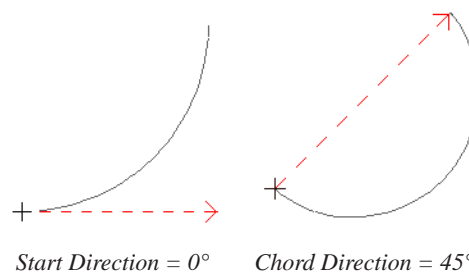

4. Define the **Radius** of the arc.
5. The **Extension** settings control the length of the arc. Define only one:
 - **Arc Angle** - The angle defined by imaginary lines drawn from the arc centerpoint to its two endpoints.

- **Arc Length** - The length of the arc itself from one endpoint to the other.
- **Chord Length** - The length of an imaginary straight line drawn from one arc endpoint to the other.

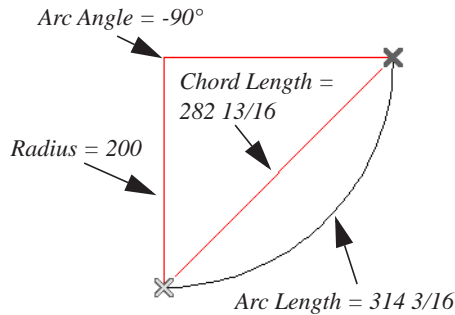

6. Select the direction the arc bends, either **cw (clockwise)** or **ccw (counter clockwise)**.
7. Click **OK** to draw the specified arc.

Click the **Num Style** button to display the **Number Style / Angle Style** dialog. See "Number Style/Angle Style Dialog" on page 89.

Arc with Arrow

 You can create an arc with an arrow on one or both ends, using the **Arc With Arrow** tool.

Draw an **Arc With Arrow**  like a regular arc. When you release the mouse button, the arc has an arrowhead at the end. The default attributes of the arrow are determined by the settings in the **Arrow Defaults** dialog. See "Arrow Defaults" on page 744.

As with regular arcs, arcs with arrows can be edited after they are created. See "Editing Arc Based Objects" on page 130 and "Arc Specification Dialog" on page 786.

Continue to draw connected lines and arcs to form a polyline with an arrowhead at the end. The arrowheads display only at the free ends, not where the lines connect. See "Polylines" on page 790.

Lines with arrowheads can also be created. See "Line With Arrow" on page 778.

 A line can be converted to an arc or vice versa by selecting the line, pressing and holding down the Alt key, then using the edit handle at either end to bend the line.

Arc Specification Dialog

 Select an arc and click the **Open Object** edit button to open the **Arc Specification** dialog.

Arc Tab

The settings on the Arc tab are also found on the Selected Arc tabs for many objects.

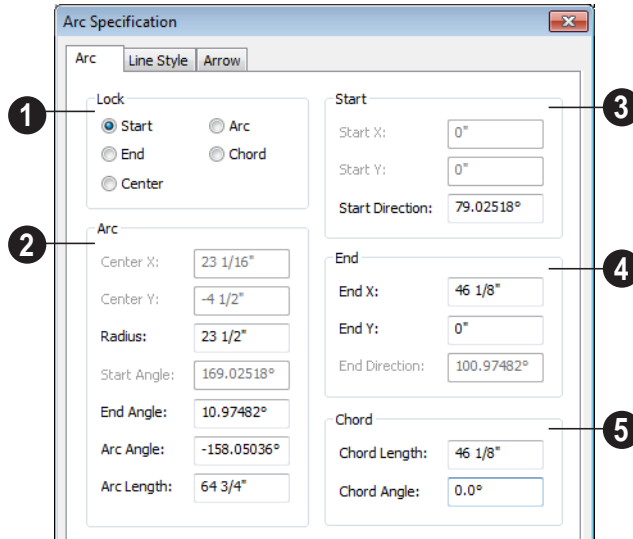

1 The **Lock** options control how changing properties on this dialog affects the arc.

- **Start** - Select this option to keep the start fixed when changing the arc, chord, or end.
- **End** - Select this option to keep the end fixed when changing the arc, chord, or start.
- **Center** - Select this option to keep the center of the arc fixed when changing the arc.
- **Arc** - Select this option to keep the arc fixed when changing the arc location.
- **Chord** - Select this option to keep the arc chord fixed when changing the arc radius.

2 **Arc** - These parameters define the arc. Various controls are disabled depending on what lock option is used.

- **Center X** - Specify the X coordinate for the center of the arc.
- **Center Y** - Specify the Y coordinate for the center of the arc.
- **Radius** - The distance between the center of the arc and the arc surface.

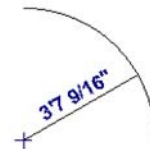

- **Start Angle** - Specify the angle that a line drawn from the arc center to the arc start makes with a horizontal line to the right.

- **End Angle** - Specify the angle that a line drawn from the arc center to the arc end makes with a horizontal line to the right.
- **Arc Angle** - The angle between the center of the arc and each end.



- **Arc Length** - The length of the arc along the curve.

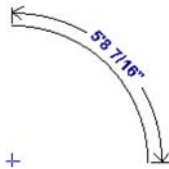

- **3 Start** - These values define the start point of the arc.
- **Start X** - Specify the X coordinate for the beginning of the arc.
- **Start Y** - Specify the Y coordinate for the beginning of the arc.
- **Start Direction** - Specify the angle of a tangent line at the start of the arc.
- **4 End** - These values define the end point of the arc.

- **End X** - Specify the X coordinate for the end of the arc.
- **End Y** - Specify the Y coordinate for the end of the arc.
- **End Direction** - Specify the angle of a tangent line at the end of the arc.
- **5 Chord** - These values define the chord of the arc.
- **Chord Length** - The straight line distance between the two ends of the arc.

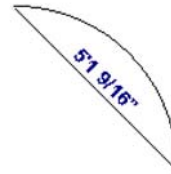

- **Chord Angle** - Specify the angle of the chord (the imaginary straight line going from the start of the arc to the end of the arc).

Line Style Tab

For information about the Line Style tab, see “Line Style Tab” on page 781.

Arrow Tab

For information about the Arrow tab, see “Arrow Tab” on page 783.

Circle Tools



Select **CAD > Circles** to access the Circle Tools.





Draw a **Circle** by dragging across the diameter. If a small circle is needed, draw a larger circle and then resize it.

Use the **Circle Specification** dialog to accurately define size, position and other attributes. See “CAD Circle/Oval/Ellipse Specification Dialog” on page 789.

Draw Circle About Center

 Select **CAD> Circles> Circle About Center** to create a circle by dragging the radius out from the center point.

To draw a Circle About Center

1. Click the **Circle About Center**  tool.
2. Click the screen to define the center.
3. Drag the radial distance and release the mouse button. If you are using **Object Snaps** , both the center point and the radius snap to any appropriate nearby CAD object, intersection or point.

Ovals

 An **Oval** is a four-arc approximation of an ellipse. To draw an oval, select **CAD> Circles> Oval**, then click and drag.

Use the **CAD Oval Specification** dialog to accurately set the length and width of the oval and other attributes.

Ellipses

 An **Ellipse** is a set of points with a constant combined distance from two points called foci. An ellipse looks like a stretched circle, or a circular surface viewed at an angle.

To draw an ellipse, select **CAD> Circles>**

Ellipse  and drag at an angle to define its maximum height and width.

Use the **CAD Ellipse Specification** dialog to accurately set the length and width of the ellipse and other attributes.

CAD Circle/Oval/Ellipse Specification Dialog

 Select a circle, oval or ellipse and click the **Open Object** edit button to open the **CAD Circle, Oval or Ellipse Specification** dialog.

The **CAD Circle, Oval and Ellipse Specification** dialogs are almost exactly the same. The **Oval** and **Ellipse Specification** dialogs have an additional setting for **Angle** on the General tab.

General Tab

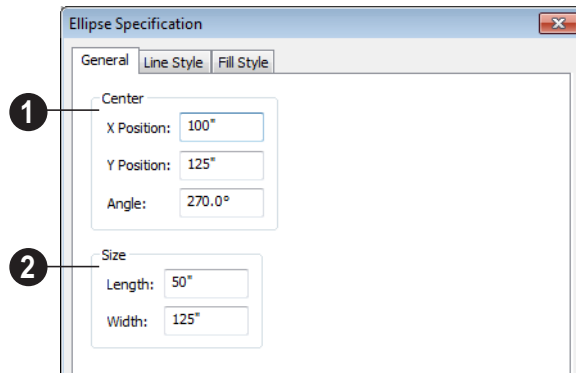

- 1 Specify the **Position** of the circle, oval or ellipse.
 - Specify the **X Position** and **Y Position** of the center of the circle, oval or ellipse.
 - Specify an oval or ellipse's **Angle**. Not available for circles.
- 2 Specify the **Length** and **Width** of an oval or ellipse, or the **Diameter** and **Radius** of a circle.

Line Style Tab



For information about the Line Style tab, see “Line Style Tab” on page 781.

Fill Style Tab

For information about the Fill Style tab, see “Fill Style Tab” on page 792.

Polylines

 A polyline consists of two or more line and/or arc segments that are attached at their endpoints. Select **CAD> Boxes> Rectangular Polyline**, then click and drag from corner to corner to create a rectangular-shaped, closed polyline.

When **Object Snaps**  is enabled and **Edit Object Parts**  is disabled, you can also create a polyline by drawing lines and/or arcs end-to-end, allowing the end of each new

object to snap to the end of the previous one. Line- and arc-based objects will only snap together to form a polyline if they are on the same layer and share identical attributes such as color, line style, and arrow specifications.

If one end of the polyline is connected to the other, it becomes a closed polyline. Closed polylines can be assigned a fill pattern and/or turned into special 3D objects such as slabs or countertops that display in 3D views.

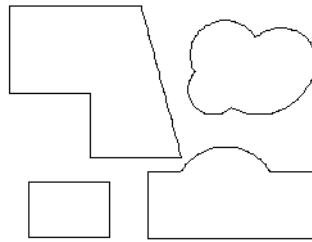

Closed Polylines

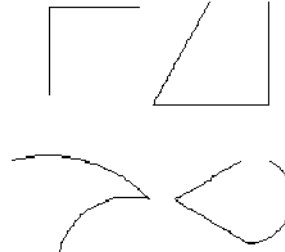

Open Polylines

Lines and polylines can be distinguished by the edit handles that display when you select each. A line displays an edit handle at each end and one in the middle. If more than three edit handles display, the object is a polyline.



Line



Polyline



Lines that appear connected to a polyline may prove to be unconnected when selected.

For example, the two polylines in the following image appear identical until their left edges are selected. The polyline on the left reveals that its left edge is not attached. In contrast, the left edge of the polyline on the right is part of the larger polyline unit.

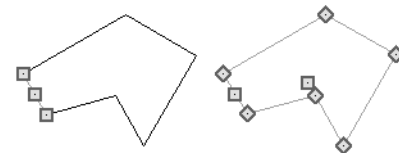

Unconnected

Connected

The **Close Polyline**  edit tool can be used to connect the edges of an open polyline. This tool adds a segment between the two open ends, closing the gap between them. See “Using Close Polyline” on page 138.

Polylines can be copied, moved, reshaped, or resized as a single unit. Additionally, the individual segments can be edited. See “Edit Object Parts” on page 125.

Once created, polylines can be edited in a variety of ways. See “Editing Open Polyline Based Objects” on page 134 and “Editing Closed-Polyline Based Objects” on page 138.

Polyline Specification Dialog



Select an open polyline, closed polyline, spline, Sprinker polyline or Electrical connection and click the **Open**

Object edit button to open the **Polyline Specification** dialog.

Polyline Tab

The Polyline tab is found in the specification dialog for open- and closed-polyline-based objects throughout the program.

The Polyline tab indicates the polyline's **Length/Perimeter**, its enclosed **Area**, and the **Volume** of a closed polyline.

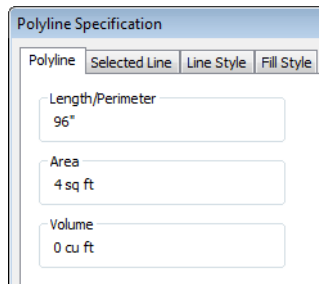

If the polyline is not closed, the Area and Volume are described as “Not closed”. The Volume of a 2D polyline will always be 0, even if it is closed.

Spline Tab

The Spline tab has a single option and is only available when the selected object is a spline. See “Splines” on page 796.

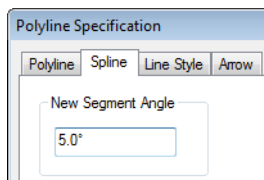

New Segment Angle - Specify the angle between line segments that are used to draw

the spline. Specifying a smaller angle makes the spline smoother. Specify a larger angle to draw the spline faster.

Selected Line Tab

The Selected Line tab is available when the selected edge of the polyline is a line as opposed to an arc. This tab is not available if the selected object is a spline. See “Editing Line Based Objects” on page 127.

Moving the Start of a line segment moves the end of the previous connected line, if there is one. Similarly, moving the End of a line segment moves the start of the next connected line, if there is one.

This tab is similar to the Line tab of the **Line Specification** dialog. See “Line Tab” on page 780.

Selected Arc Tab

The Selected Arc tab is available when the selected segment of the polyline is an arc as opposed to a line. This tab is not available if the selected object is a spline.

This tab is similar to the Arc tab of the **Arc Specification** dialog. See “Arc Tab” on page 787.

Line Style Tab

This tab is similar to the Line Style tab in the **Line Specification** dialog. See “Line Style Tab” on page 781.

Fill Style Tab

The information on the Fill Style tab for polylines is similar to that for many other

objects in the program, including closed CAD shapes and a variety of architectural objects.

The Fill Style tab is not available for Sprinkler Lines or Electrical Connections as these tools cannot be used to form closed shapes.

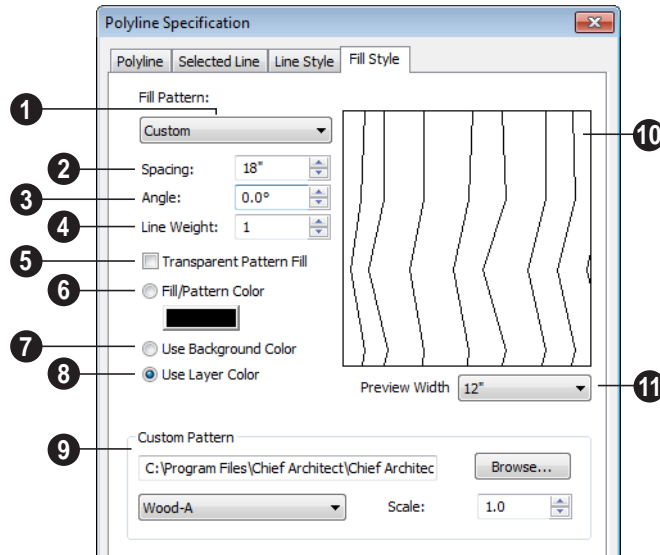

1 Fill Pattern - Choose a fill pattern from the drop-down list. If the **Custom** pattern is selected, the Custom Pattern options become available below.

The options that follow are disabled until you select a pattern other than **None** from the **Fill Pattern** drop-down list.

- 2** Define the **Spacing** of the selected fill pattern. Hatch spacing set at 12" matches grid/reference spacing set at 12".
- 3** Define the **Angle** of the selected fill pattern.
- 4** Set the **Line Weight** for the selected fill pattern.
- 5** Check **Transparent Fill** to make the fill pattern transparent. When you

check this option, any objects behind the fill pattern are visible through it.

6 Fill Color - Select a line color for the fill pattern, or fill color if a solid fill is specified. The layer color is used by default. See "Color Chooser Dialog" on page 652.

7 Select **Use Background Color** to use the background color for solid fills or patterns.

8 Check **Use Layer Color** to have the fill pattern use the layer color for the pattern lines. If it is a solid fill, the fill color is the same as the layer's color.

9 The **Custom Pattern File** section is only enabled when "Custom" is selected from the **Fill Pattern** list.

- Click the **Browse** button to open the **Custom Pattern File** dialog and select a pattern (**.pat**) file from the Home Designer Pro Patterns directory or a custom **.pat** file elsewhere on your computer. The selected **.pat** file's path name displays and can be edited in the text field.
 - Select a **Pattern** from the drop-down list. This list includes all custom patterns available in the selected file.
 - Specify a **Scale** for the selected Custom pattern. This setting affects all instances of the pattern in the current plan or layout file - not just in the selected object(s).
- 10** A preview of the selected pattern displays here. As changes are made to

the settings on this tab, the preview will update.

- 11** Choose a **Preview Width** from the drop-down list. This value controls how large an area the preview represents. The selected value indicates the length of each side of the preview in actual plan inches (mm).

Arrow Tab

The Arrow tab is available for most open polylines and splines and is similar to the Arrow tab of the **Line Specification** dialog. See "Arrow Tab" on page 783.

The Arrow tab is not available for closed polylines, Sprinkler Lines or Electrical Connections.

Box Tools



Select **CAD> Boxes** to access the Box Tools.

Rectangular Polyline



A **Rectangular Polyline** can be drawn in either of two ways:

- Click in the drawing area to place a 24" x 24" square polyline at that location.
- Click and drag from corner to corner to draw a rectangle of any size.

Once created, a rectangular polyline can be edited into any shape or converted to a 3D object. See "Editing Closed-Polyline Based Objects" on page 138.

Box



Draw a 2D box from the midpoint of one side to the midpoint of the opposite side. The sides of a box can be resized, but a box always has four 90° corners.

Boxes have some unique editing behaviors. See "Editing Box-Based Objects" on page 141.

Cross Box



The **Cross Box** behaves the same as a box. The only difference is the cross that is automatically drawn whenever this tool is used. Use the Cross Box to add 2D framing details to cross section views.

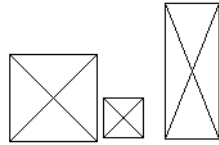

Cross boxes are automatically maintained at ends of framing members cut by a cross section cutting plane. They automatically update when the cross section is first created and whenever you click **Fill Window** .

You may want to create and resize one cross box for each framing member size used, such as 2x4, 2x6, 2x12, then copy and paste the original as needed. It is easiest to resize using **Box Specification** dialog.

Insulation



Use the **Insulation** tool to draw insulation in cross section details.

Drag the length of the insulated area, then select the object and use the edit handles to move or resize it. It may be easier to use the **Box Specification** dialog to define the insulation width and length exactly.

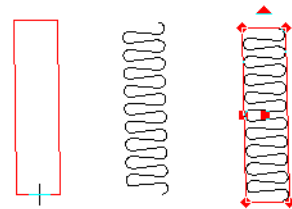

*Drag to
create*

Result

*Select
to edit*

Box Specification Dialog



Select a CAD box, a framing box, a cross box, or insulation and click the **Open Object** edit button to open the **Box**

Specification dialog. See “Box Tools” on page 794.

General Tab

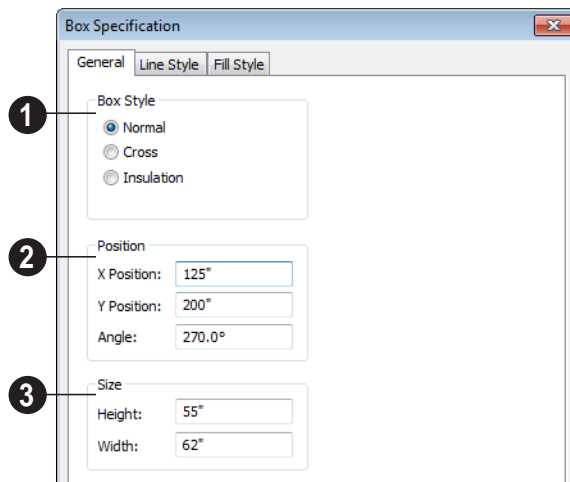

1 Specify a **Box Style**. Select **Normal** to specify a normal box, **Cross** to specify a cross box, or **Insulation** to specify an insulation box. If multiple CAD boxes are selected, “No Change” may display.

2 Define the **Position** of the box.

- Specify the **X Position** and **Y Position** of the center of the box.
- Specify the **Angle** of the box.

3 Define the **Size** of the box by specifying its **Height** and **Width**.



To find out which direction is the height and which is the width of a square box, select it. The triangular rotate handle is nearest the side you originally dragged from when creating the box. Changing the height changes the length of this side.

Line Style Tab

For information about the Line Style tab, see “Line Tab” on page 780.

Fill Style Tab

For information about the Fill Style tab, see “Fill Style Tab” on page 792.

Splines





A Spline is a curve that passes smoothly through a set of points. Splines are typically used in situations where there is an irregular curve. A contour line is a

typical example. Splines are useful wherever a free-flowing curve is needed.

Once created, splines can be selected and edited. See “Editing Spline Based Objects”

on page 144 and “Polyline Specification Dialog” on page 791.

To use the Spline tool

1. Select **CAD> Spline** .
2. Draw the first spline segment just as you would a line. A single spline segment looks identical to a line. You may need to turn off **Angle Snaps**  to draw freely.

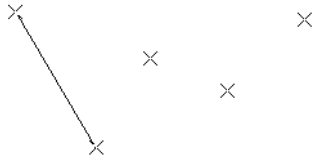

3. Draw the second segment from the end of the first at a different angle. **Object Snaps**  should be on to assure that new segments attach correctly to the ends of previous segments.

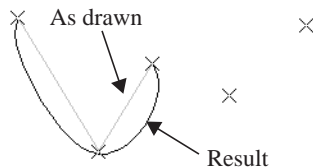

4. As soon as two straight spline segments connect end-to-end, the straight segments become a curve that passes through the endpoints defined by the original segments. Each point is called a vertex.

5. Draw a few more segments, connecting each to the free end of a previously drawn segment.

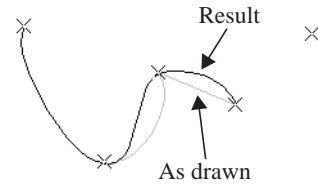

6. Notice as additional segments are drawn that the spline changes the curvature of the previous segment to create a continuous curve between the last three points.

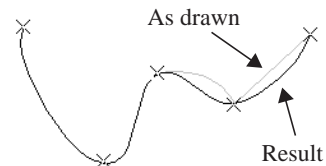

7. Form a closed spline by drawing a segment between its two free ends.

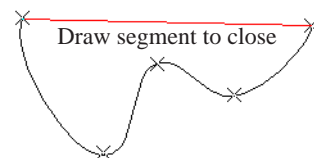

8. The result is an irregular curve that flows smoothly through each vertex.

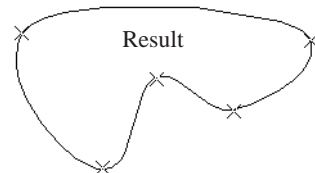

Spline-based objects will only snap together to form a single spline if they are on the same

layer and share identical attributes such as color, line style, and arrow specifications.

Displaying CAD Objects

As with architectural objects, the display of CAD objects is controlled in the **Layer Display Options** dialog. See “Layer Display Options Dialog” on page 104.

CAD objects can be drawn in floor plan view, layout, and cross section/elevation views. They are 2D objects only, though, so they cannot be seen in any view other than the one they are drawn in and are never visible in camera views or overviews. See “Architectural vs CAD Objects” on page 108.

Show Length and Angle

You can specify that line segment length and angle display along a CAD line, CAD arc, or along each segment of a CAD polyline. If the

segment is an arc, its radius also displays. See “Line Style Tab” on page 781.

The format of the length and angle can be specified in the **CAD Defaults** dialog. See “CAD Defaults Dialog” on page 770.

Line length and angle indicators use the Text Style assigned to the layer that their CAD object is on. See “Text Styles” on page 765.

Endcaps

Dashed lines often display endcaps, which are dashes of a particular length. You can specify the Printed Length of endcaps in the **Preferences** dialog. See “Line Properties Panel” on page 75.

Project Management

The tools described in this chapter let you draw plans with ease and flexibility, run checks on plans so you can be more confident that they are free of code violations and common drawing errors, and consider loan calculations for your projects.

Chapter Contents

- House Wizard
- Plan Check
- Loan Calculator

House Wizard

 The **House Wizard** is a time-saving feature used to create a preliminary room-by-room design of a home without getting caught up in the details. Once the shape and layout of the rooms are finalized, the **House Wizard** converts them into a working plan that can be edited and detailed to completion.

Start House Wizard

 Select **Tools> House Wizard> Start House Wizard**. The **House Wizard** leads you through a series of windows that gather information about the rooms you want to include in your house. When you click

Finish and close the **House Wizard**, the selected room boxes display.

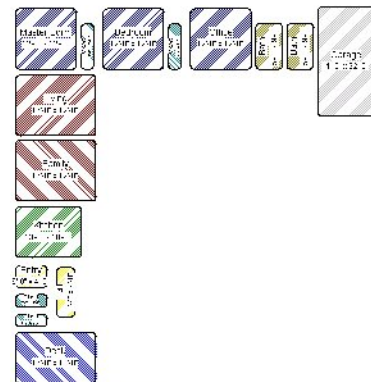

Room boxes can now be arranged into a floor plan.

Placing Room Boxes

In addition or as an alternative to the room boxes created for you by the **House Wizard**, you can create your own room boxes. To do so, select **Tools > House Wizard** , then choose the desired room type from the submenu. Click in floor plan view to place a room box of the selected type at that location.

Displaying Room Boxes

Room boxes and their labels are located on the “House Wizard Room Boxes” layer. Room box labels use the Text Style assigned to that layer, as well. See “Displaying Objects” on page 102.

Editing Rooms

Once created, room boxes can be edited in a variety of ways.

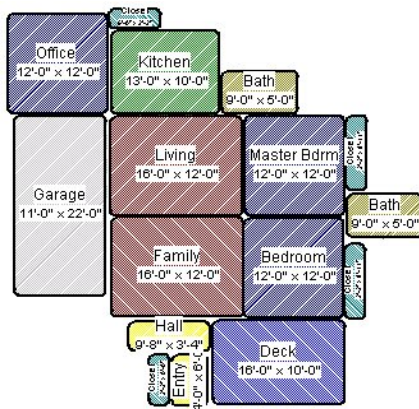

- Select room boxes using the **Select Objects**  tool just like other objects in Home Designer Pro. See “Selecting Objects” on page 124.
- Room boxes can be resized, rotated, and rearranged. See “Editing Box-Based Objects” on page 141.
- Try to line up the rooms so that they are just touching. Excessive overlaps may cause your rooms to form incorrectly. Closets are the exception. You can overlap a room with a closet, or place inside another room box.
- Rooms can be copied and pasted using the **Copy/Paste**  edit button and deleted using the **Delete**  edit button.
- Select **Tools > House Wizard**  or click the **Space Planning Configuration**  button to access the room box tools and place additional room boxes in your plan. Select a tool and click in the plan to place a room box of that type.



- Select **Tools > House Wizard > Hide Room Boxes**  or click the toggle button to hide or show the room boxes.

Build House

When the rooms are in place, select **Tools > House Wizard > Build House**  to convert the rooms into a building model. Walls and doors are inserted between the rooms that you arranged.

Multiple Floors

If you specified a two-story house, follow these steps:

1. Edit and arrange the room boxes on Floor 1 as desired.
2. Select **Tools> House Wizard> Build House**  tool to create the walls on the first floor.
3. Go **Up One Floor**  and notice that the positions of the walls on Floor 1 display in red as a reference.
4. Arrange the rooms on Floor 2 as desired, using the reference display as a guide.
5. On the second floor, select **Tools> House Wizard> Build House**  to complete the second floor.

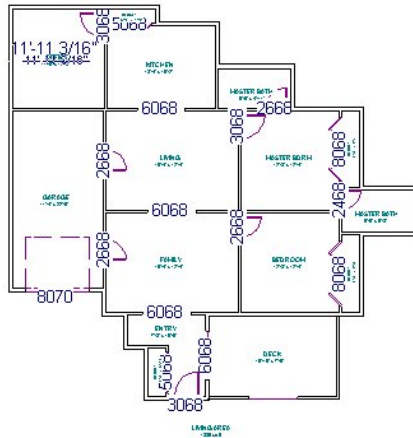

When you Build House, the “House Wizard Room Boxes” layer is automatically turned off. The room boxes that you created are not deleted, however.

Plan Check



Plan Check checks the floor of your plan currently shown on screen for anything that appears to violate common building practices. Plan Check may not find all the problems in a plan, but does it point out areas that may need improvement.

As your plan evolves, a number of things that may become incorrect can be fixed using Plan Check. For example, doors that change from exterior to interior as you add new rooms are redrawn without the threshold line that marks an exterior door. A cabinet, fixture or furniture item that is against a wall because the wall was moved into it, as

opposed to the item moving, are attached to the wall.



Disclaimer: The Plan Check feature in Home Designer Pro compares your plan with common building practices. Plan Check does not claim to detect all building code and design requirements. Always have your plans checked by a licensed professional before beginning actual construction.

To run Plan Check, select **Tools> Checks>**

Plan Check .

Plan Check Dialog

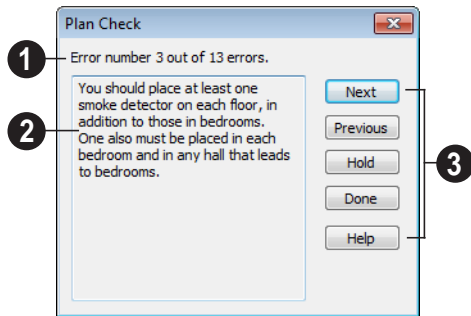

- 1 The current error number, along with the total number of errors found.
- 2 A description of the current error displays here.
- 3 Options for navigating Plan Check are found on the right side.
 - Click **Next** to ignore the current error and proceed to the next.
 - Click **Previous** to return to the previous error.
 - Click **Hold** to suspend Plan Check so you can fix the current error. Select **Tools> Checks> Plan Check** again and the check starts where it left off.
 - Click **Done** to terminate Plan Check.

Potential plan errors found are usually highlighted in floor plan view. To ensure the highlighted item is on-screen, make sure the entire plan is shown in the window before



you run **Plan Check** .

If this dialog obscures the floor plan view, drag its title bar to move it. It remembers its new position and displays there the next time

Plan Check  is run.

Room Types

Plan Check  can do a much better job of checking for problems if it knows what the rooms in your plan are to be used for, so you should assign a Room Type to each room in your plan. See “Room Types” on page 234.

The first time **Plan Check**  runs in a plan, it automatically assigns a room type to as many undesigned rooms as it can. Some rooms are determined by their size and shape, and others by their contents. For example, a shelf in a small room indicates a closet; a stove or refrigerator indicates a kitchen; or a bed, a bedroom. If the program cannot assign a room type, **Plan Check**  highlights it and suggests that you do so manually.

Loan Calculator



Select **Tools> Loan Calculator** to open the **Loan Calculator** dialog. This dialog lets you calculate different aspects of

a loan for the current plan based on a variety of parameters.

The screenshot shows a 'Loan Calculator' dialog box with the following elements:

- 1** Points to the 'Calculate:' dropdown menu, which is currently set to 'Monthly Payment'.
- 2** Points to the 'Result' section, which displays 'The Monthly Payment is: \$665.30' and a '=' button.
- 3** Points to the 'Required Fields' section, which includes input fields for:
 - Loan Amount: \$100,000.00
 - Term: 30.0 yrs.
 - Interest Rate: 7.0%
 - Monthly Payment: \$665.30
- 4** Points to the 'Optional Fields' section, which includes input fields for:
 - Property Taxes: \$0.00 / yr.
 - Homeowner's Insurance: \$0.00 / yr.
 - Private Mortgage Insurance (PMI): \$0.00 / yr.
 - Other Fees: \$0.00 / yr.

At the bottom of the dialog are 'Done', 'Reset', and 'Help' buttons.

1 Specify what aspect of the loan you would like to calculate from the **Calculate** drop-down list:

- Monthly Payment
- Loan Amount
- Term
- Interest Rate

2 The calculation **Result**, based on the information you provide, displays here.

If you make changes to any of the fields in the dialog, click the = button to refresh the **Result**.

3 The **Required Fields** are the same as the options in the **Calculate** drop-down list. The option selected under **Calculate** will be inactive under **Required Fields**.

- Specify the desired **Loan Amount**.
- Specify the desired **Term**, in years.
- Specify the desired **Interest Rate**.
- Specify the desired **Monthly Payment**.

4 The **Optional Fields** allow you to include additional information in your loan calculation.

- Specify the expected **Property Taxes** per year.
- Specify the expected **Homeowner's Insurance** cost per year.
- Specify the expected **Private Mortgage Insurance (PMI)** cost per year.
- Specify the cost of any expected **Other Fees**.

When Monthly Payment is calculated, each Optional value is divided by twelve (months) and then added to the total payment.

When a Calculate option other than Monthly Payment is selected, these values are divided by twelve (months) and then subtracted from the specified Monthly Payment value. The result, which does not display, is then used to determine the Loan Amount, Term or Interest Rate.

Pictures, Images, & Walkthroughs

Home Designer Pro uses picture files in a variety of ways to enhance your drawings.

The Library Browser contains images of real world objects like plants, vehicles, and people that can display in 3D views.

Picture files can also be imported into Home Designer Pro and shown in most views.

You can save any view using a variety of picture file formats. In addition, Home Designer Pro allows you to create virtual tours that can be saved as **.avi** files, shared with others, and played back later.

Chapter Contents

- Picture Files vs Pictures and Image Objects
- Images
- Displaying Images
- Editing Images
- Image Specification Dialog
- Pictures
- Picture File Box Specification Dialog
- Metafiles
- Metafile Box Specification Dialog
- Displaying Pictures and Metafiles
- Editing Pictures and Metafiles
- Copy Region as Picture
- Walkthroughs
- Walkthrough Path Specification Dialog

Picture Files vs Pictures and Image Objects

In common computer language, picture files, pictures and images are more or less synonymous. In the Home Designer Pro environment, however, there are some notable differences between these terms.

In Home Designer Pro, a two dimensional image file such as a .bmp, .jpg, .gif, or .png is referred to as a picture file or an image file. Examples of these files are saved on most computers and can be opened in a variety of applications.

A Picture, on the other hand, is a file that has been imported into the program. Pictures can be imported into floor plan view, cross section/elevation views, and layout pages.

They are two-dimensional only and do not display in camera views or overviews.

An Image object is also based on a picture file, but it does display in both 2D and 3D views. Images have 3D width and height data associated with them, as well as a 2D symbol which displays in floor plan view.

Picture files have additional uses in Home Designer Pro, as well:



- Backdrops are picture files that display behind 3D views. See “3D Backdrops” on page 679.
- Textures are picture files that realistically represent materials in 3D views. See “About Materials” on page 632.

Images



Images add realistic detail to 3D views without adding many surfaces to the model. For example, a tree image with a single surface can be used instead of a tree symbol with thousands, dramatically improving realism without compromising drawing time.

There are two types of Images in Home Designer Pro:

- **Images**  rotate so that they always face the camera in 3D views.
- **Billboard Images**  do not rotate to face the camera. An example of when this may be useful is an image of a trellis, which might look awkward when facing a camera from a side view.

Placing Images



A selection of Images are available in the Library Browser. Select one and click in a floor plan view, camera view or overview to place it. See “Placing Library Objects” on page 620.



Creating Images



Custom Images can be added to the Library Browser, as well as created in plan files. Home Designer Pro can use any image with a *.bmp, *.jpg, *.png, *.gif, *.tif, *.pcx, or *.tga extension.

Generally, .png files work best as Images because this format has good compression and allows for the Image to contain transparency information.

To create an Image in floor plan view

1. In floor plan view, select **Build> Image> Create Image**  or **Billboard Image**  to open the **Image Specification** dialog. See “Image Specification Dialog” on page 809.
2. On the Image tab:
 - Click the **Browse** button to select a picture file on your computer or enter the path to a valid picture file in the **Image File** field.
 - Select or 2D plan symbol to represent the image in floor plan view. Choose a **2D Plan Symbol** from the list or click the **Library** button and select a symbol from the library. See “Image Tab” on page 809.
 - Enter **Height** and/or **Width** and **Location** information.
3. Specify transparency information on the Transparency tab.
4. Click OK to close the **Image Specification** dialog.

5. Click to place the new Image in floor plan view.

To create an image in the Library Browser

1. In the Library Browser, right-click on an unlocked folder.
2. Select **New> Image** from the contextual menu to open the **Image Specification** dialog.
3. Browse to the image file you want to add and select your other options. See “Image Specification Dialog” on page 809.
4. Once created, the image is listed in the library folder that you right-clicked on. Size and other data is saved.

Using Paste Image



You can also import an image by first copying it to the Windows Clipboard, then navigating to a Home Designer Pro window and selecting **Edit> Paste> Paste** from the menu. See “Paste Special” on page 117.

Displaying Images



The display of images in floor plan and 3D views is controlled in the **Layer Display Options** dialog. See “Displaying Objects” on page 102.

Images are placed on the “Images” layer.

In Floor Plan View

In floor plan view, most images are typically represented by an Image  symbol. You can specify a different symbol to represent an

image if you wish. See “Image Specification Dialog” on page 809.

In 3D Views

The actual picture associated with an image object can be seen in 3D views. It is sized according to its Width and Height specifications. Any transparency data associated with the image is also applied. See “Image Specification Dialog” on page 809.

Images can be set to either rotate so that they always face the camera or to remain stationary, like billboards. See “Images” on page 806.

You can also choose to turn off the display of images in rendered 3D views in the **Preferences** dialog. See “Render Panel” on page 86.

In Layout

The symbols representing images in floor plan view can display on a layout sheet and be printed or plotted. See “Sending Views to Layout” on page 866.

Editing Images

Images can be selected in 2D and 3D views and edited using the edit handles, edit tools and the **Image Specification** dialog.

Using the Mouse

Images can be resized in floor plan view by dragging the circular Resize handle at the top of the 2D symbol.

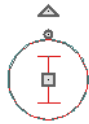

Images can also be resized in 3D views by dragging the circular Resize edit handle at the top.



When an image is resized, the aspect ratio of the image and its 2D symbol are retained, so the image resizes proportionally.

Using the Edit Tools

A selected image or images can be edited in a variety of ways using the buttons on the edit toolbar. As with most objects, images can be copied, replicated, moved, deleted, etc. See “The Edit Toolbar” on page 29.

Image Specification Dialog



Select an image and click the **Open Object** edit button to open the **Image Specification** dialog.

Image Tab

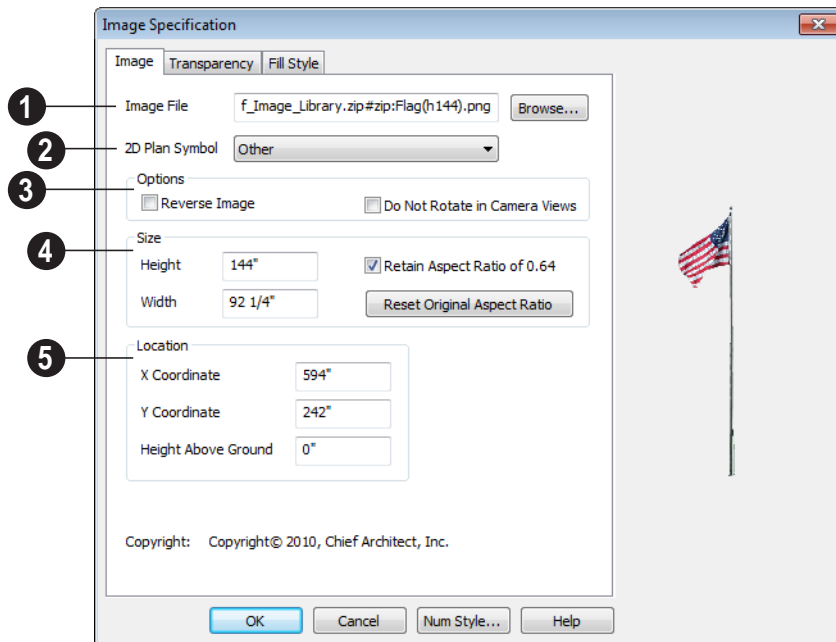

- 1 **Image File** - The path and name of the selected Image. You can click **Browse** to replace the current image file with a different one saved on your computer.
- 2 Select a **2D Plan Symbol** from the drop-down list to represent the Image in floor plan view. See “Displaying Images” on page 807.
 - Click the **Library** button to choose a from the library to act as the Image’s 2D

symbol. See “Select Library Object Dialog” on page 622.

- 3 **Options**
 - Check **Reverse Image** to reflect the appearance of the image about an imaginary vertical line through its center.
 - Check **Do Not Rotate in Camera Views** to prevent the image from rotating to face the camera in 3D views. This box is

checked for Billboard Images. See “Images” on page 806.

- 4 Specify the **Size** of the image as it displays in 3D views.
 - Enter a **Height** for the selected image.
 - Enter a **Width** for the selected image.
 - When **Retain Aspect Ratio of** is checked, if you change either the Height or Width, the other value changes to maintain this ratio. If this is unchecked

and you resize the image, it may become distorted.

- Click **Reset Original Aspect Ratio of** to reset the image’s original aspect ratio and remove any distortion caused by resizing.
- 5 Specify the **Location** of the selected image.
 - Position the selected image precisely by specifying its **X and Y Coordinates**.
 - Specify the image’s **Height Above Ground**.

Transparency Tab

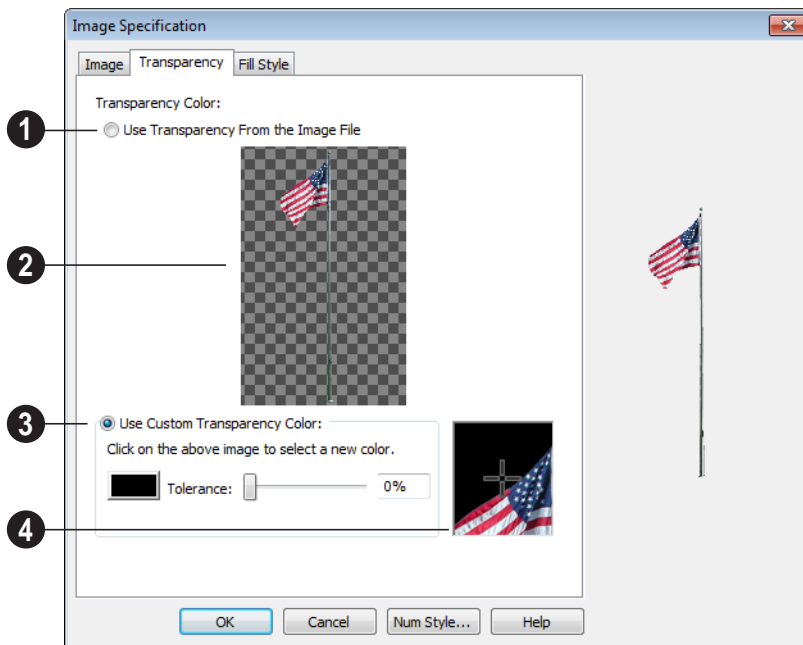

- 1 Click the **Use Transparency From The Image File** radio button to use any transparency data included in the image file.

- 2 A preview of the image displays here. If you select Use Custom Transparency Color, below, you can move your mouse pointer over this image to select a specific color to use as the Transparency Color.

- 3 Click the **Use Custom Transparency Color** radio button to specify another color to represent the transparency.
 - Place your pointer over the preview image above. The pointer changes to an eyedropper and a magnified preview displays below. Click to select the color of the pixel your pointer is over as the transparency color. The selected color displays in the Color box, below.
 - Click the Color box to select a color in the **Color Chooser** dialog. See “Color Chooser Dialog” on page 652.
 - Enter a level of **Tolerance** to be applied to colors that are almost the same color as the specified transparency color. Use the slide bar or type a number in the edit box.
- 4 A magnified preview of the area in the preview image above displays here, allowing for accurate pixel selection.

Note: The image preview will display its original orientation, even if Reverse Image is checked on the Image tab.

The Transparency Color

If the portion of the image file that you wish to use contains the transparency color, that part of the image also becomes transparent. If this happens, the image may appear partially disintegrated.

You may need to experiment to find the best transparency color and tolerance for the image.

Fill Style Tab

For information about the settings on this tab, see “Fill Style Tab” on page 792.

Pictures

A variety of picture file types can be imported into and exported out of Home Designer Pro.

Metafiles are also types of picture files that can be imported and exported. See “Metafiles” on page 814.

Exporting Pictures





Using the **Export Picture** tool is similar to creating a screen capture of everything in the current Home Designer Pro view window. Pictures can be saved in various file formats and used in other applications.

Export Picture  is best suited for rendered views. When exporting a line-based view, best results can be achieved by saving it as a Metafile. See “To export a metafile” on page 815.

To export a picture

1. Open the view that you would like to export as a picture file.
2. Zoom, pan or otherwise adjust the view so that what you see on screen suits your needs. See “Displaying 3D Views” on page 677.

3. Select **File> Export> Picture (BMP, JPG, PNG)**  in any view to open the **Export Picture File** dialog. See “Exporting Files” on page 45.

The **Copy Region as Picture**  tool also lets you create a picture file based on the current view, but allows you to specify what portion of the view is exported. See “Copy Region as Picture” on page 819.

Importing Pictures

 Pictures can be imported into and displayed in floor plan view, cross section/elevation views, and layout pages. Pictures do not display in camera views or overviews. See “Displaying Pictures and Metafiles” on page 817.

There are several ways to import a Picture into Home Designer Pro:

- Select **File> Import> Picture (BMP, JPG, PNG)**  to open the **Import**

Picture File dialog, which is a typical open file dialog. See “Importing Files” on page 49.

- Click and drag an image file from a Windows Explorer window into the Home Designer Pro window.
- In any application, copy an image to the Windows Clipboard, then select **Edit> Paste> Paste**  from the Home Designer Pro menu in an eligible view window. See “Paste Special” on page 117.

Note: Importing large, or multiple, Pictures into a plan or layout file can result in program slowness.

An imported picture is placed in the center of the current view. Once imported, pictures can be selected and edited. See “Editing Pictures and Metafiles” on page 817.

Picture File Box Specification Dialog

 Select an imported picture file and click the **Open Object** edit button to open the **Picture File Box Specification** dialog.

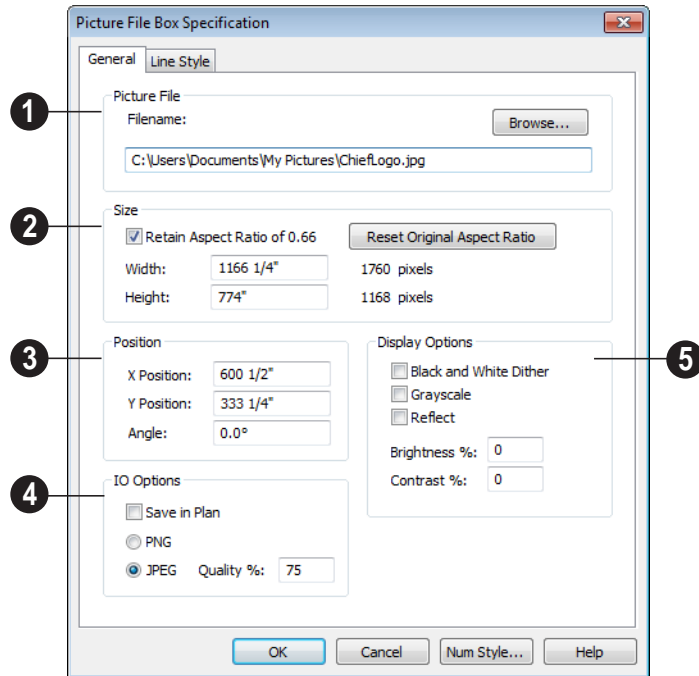

- 1** **Filename** - The full pathname for the picture file. Type a new name to change the picture assigned to this box.
 - Click the **Browse** button to choose a new picture file or to relink to a missing file.
- 2** Specify the **Size** of the picture in plan inches (mm).
 - Check **Retain Aspect Ratio** to maintain the width to height ratio of the original image. If you change one value, the other

- recalculates so the image is not stretched or distorted as it is resized.
- **Reset Original Aspect Ratio** - If the aspect ratio is changed, you can click this button to return the picture to its original aspect ratio.
- Specify the desired **Width** of the picture box in plan inches. The original width in pixels displays to the right.

- Specify the desired **Height** of the picture box in plan inches. The original height in pixels displays to the right.

3 Specify the **Position** of the picture.

- **X Position** - The location of the picture box relative to the absolute origin.
- **Y Position** - The location of the picture box relative to the absolute origin.
- **Angle** - The current angle of the picture box relative to a horizontal line pointing towards the right hand side of the screen.

4 **Input/Output (IO) Options** - Specify how the image file information is stored in the plan or layout file.

- Check **Save in Plan** to embed the picture in the plan or layout file. If a picture file is embedded, you do not need to include it when sending the plan or layout to a different computer.
- Click the radio button beside either **PNG** or **JPEG** to specify how to save the embedded picture data. Pictures that were originally **.jpg** or **.tga** files use the **JPEG** option by default; those that were **.gif** or **.png** files use the **PNG** option by default.
- Specify the picture's **Quality %**. when **JPEG** is selected. A lower value results in better compression, while a higher value reduces data loss.

Note: PNG is the better option for pictures of line drawings, text, or large areas of a single color. JPEG is the better option for photos.

5 Choose from a variety of **Display Options**.

- Check **Black and White Dither** to dither the selected picture file. Dithering creates a two tone effect that may produce better results when printed.
- Check **Grayscale** to replace the color in the selected picture file with shades of gray.
- Check **Reflect** to reverse the image.
- Enter a degree of **Brightness** from 1 - 100%.
- Enter a degree of **Contrast** from 1 - 100%.

Line Style Tab

The settings on this tab are similar to those on the Line Style tab in numerous other dialogs, with one exception.

Uncheck the **Show Outline** box to turn off the display of the picture's border polyline.

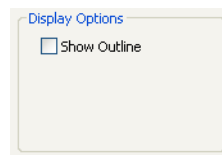

See "Line Style Tab" on page 781.

Metafiles

A metafile (**.emf**, **.wmf**) is a special picture file format made up of vectors (lines) that

allow the image to be rescaled without loss of quality.

High resolution pictures of line-based views can be exported as a metafile.



Exporting Metafiles



An enhanced metafile (.emf) can be exported from any line-based view: that is, from floor plan view and 3D Vector Views.

Only objects that display on screen are included in an exported metafile.

To export a metafile

1. Accurately position the view on screen.
2. Select **File> Export> Metafile (EMF)** .
3. Drag a marquee  from corner to corner, defining the area that will included in the metafile.
4. Release the mouse to open the **Metafile Size** dialog.

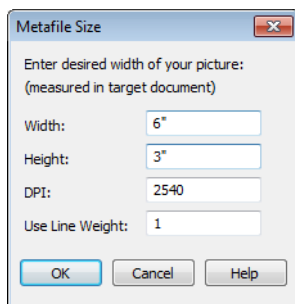

5. Specify the desired **Width** or **Height** of the metafile. When one value is edited, the other changes to maintain its aspect ratio.

Specify, too, the desired **Dots Per Inch (DPI)** for the metafile. A larger value

results in a higher quality metafile, but also a larger file size.

6. When a metafile is exported from a 3D Vector View, you can also specify the printed thickness of lines in the view. To increase the printing line weight, type a larger number in the **Use Line Weight** field. See “Vector View” on page 711.
- Metafiles exported from floor plan view use the line weights defined in the **Layer Display Options** dialog. See “Layer Display Options Dialog” on page 104.
7. Click OK to open the **Export Metafile** dialog, which is a typical Save As dialog. See “Saving, Exporting, and Backing Up Files” on page 43.
 8. Enter a name and location on your computer for the metafile, then click **Save**.

Importing Metafiles



Metafiles can be imported into and displayed in floor plan view, cross section/elevation views, and layout pages. Metafiles do not display in camera views or overviews. See “Displaying Pictures and Metafiles” on page 817.

There are two ways to import a metafile into Home Designer Pro:

- Select **File> Import> Metafile (EMF,WMF)**  to open the **Import Metafile** dialog, which is a typical open file dialog. See “Importing Files” on page 49.
- You can also click and drag a metafile file from a Windows Explorer window into the Home Designer Pro window to import it.

An imported metafile is placed in the center of the current view. Once imported, metafiles

can be selected and edited. See “Editing Pictures and Metafiles” on page 817.

Metafile Box Specification Dialog



Select an imported metafile and click the **Open Object** edit button to open the **Metafile Box Specification** dialog.

General Tab

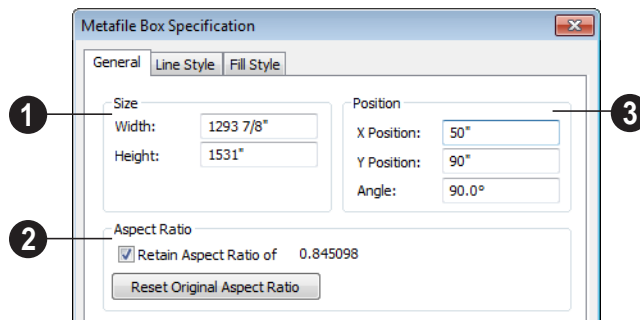

1 The metafile’s Size displays here. You can enter a different **Width** or **Height**.

2 Check **Retain Aspect Ratio** to maintain the aspect ratio when the **Width** or **Height** values are edited. Click **Reset Original Aspect Ratio** to reset the metafile to it’s original size if it has been edited.

3 The metafile’s current Position and orientation display here. Enter a new **X Position** and/or a **Y Position** to relocate the Metafile in absolute coordinates. You can also change the Metafile’s **Angle**.

Line Style Tab

The settings on this tab are similar to those on the Line Style tab in numerous other dialogs, with one exception.

Uncheck the **Show Outline** box to turn off the display of the picture’s border polyline.

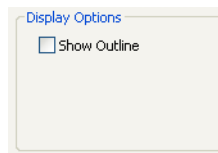

See “Line Style Tab” on page 781.

Fill Style Tab

For information about the Fill Style tab, see “Fill Style Tab” on page 792.

Displaying Pictures and Metafiles



The display of pictures and metafiles is controlled in the **Layer Display Options** dialog. See “Displaying Objects” on page 102.

Pictures and metafiles are placed on the “CAD, Default” layer.

Pictures and metafiles can be imported into and displayed in floor plan view, cross section/elevation views, and layout pages. A picture or metafile can only be seen in the view where it was imported and cannot be imported into a camera view or overview.

Drawing Groups

By default, imported pictures are placed in the Back Drawing Group, and imported metafiles are placed in the Default Drawing Group. Once imported, they can be moved to a different group. See “Drawing Groups” on page 150.

In Layout

Pictures and metafiles are included when a view is sent to layout, and can also be imported directly onto a layout page. See “Pictures and Metafiles in Layout” on page 869.

Editing Pictures and Metafiles

Pictures and metafiles can be selected and edited using the edit handles, the edit toolbar, and their specification dialogs.

Using the Mouse

Pictures and metafiles can be edited like CAD boxes. See “Editing Box-Based Objects” on page 141.

In the Specification Dialog

Pictures and metafiles can be customized in their specification dialog. See:

- “Picture File Box Specification Dialog” on page 813
- “Metafile Box Specification Dialog” on page 816

Using the Edit Handles

A selected picture or metafile can be resized, moved, and rotated using the its edit handles. See “Editing Box-Based Objects” on page 141.

Using Dimensions

Pictures and metafiles can be relocated relative to other objects with precision using dimensions.

To avoid changing the selected object’s aspect ratio, make sure you choose to move the entire object rather than the selected edge. See “Moving Objects Using Dimensions” on page 737.

Using the Edit Tools

A selected picture or metafile can be edited in a variety of ways using the buttons on the edit toolbar. See “The Edit Toolbar” on page 29.

Point to Point Resize



A selected picture or metafile can be resized in either the X or Y direction with the **Point to Point Resize** edit tool.

To use the Point to Point Resize tool

1. Select a picture box, metafile box, or PDF box.
2. Click the **Point to Point Resize**  edit button.
3. Click on two points in the selected object's box area that have a known distance between them.
4. After you click at the second point, the **Point to Point Resize** dialog opens showing the current distance between the points.

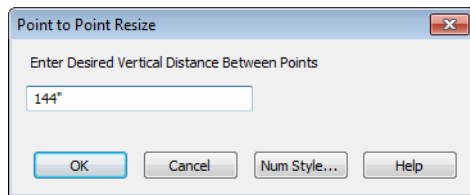

5. Enter a new dimension that matches the desired distance between the points.
6. Click **OK** to resize the picture, metafile, or pdf.

Resize Factor

With a bit of calculation, an imported picture or metafile can be resized to scale using the **Transform/Replicate Object** dialog. Once resized, the information in the object box can be traced using Home Designer Pro's drawing tools and then deleted.



It is a good idea to delete a resized picture after it is traced to help avoid program slowness and limit your plan or layout file's size.

To calculate the Resize Factor

1. Find two items in the imported object that are separated by a known horizontal or vertical distance, such as two walls or plot lines.
2. Draw parallel CAD lines on top of these two items. See “The CAD Drawing Tools” on page 771.
3. Find the distance between the CAD lines. See “The Dimension Tools” on page 728.
4. The Resize Factor for the image is the distance described in the picture divided by the distance between the CAD lines.

For example, if the items are supposed to be 10 feet apart on the picture, but the distance between the two CAD lines drawn on them is only 2 feet, you need to set the Resize Factor for the picture to 5. (10' divided by 2' equals 5). When the picture is 5 times the original size, the items on the picture are at the actual scale shown on the picture.

5. Select the picture and click the **Transform/Replicate Object**  edit button.



6. In the **Transform/Replicate Object** dialog, select the **Resize Factor** check box.
7. Enter the Resize Factor calculated above, then click **OK**.

Copy Region as Picture



You can copy any portion of the screen and save it as a picture file using the **Copy Region as Picture** tool. See “Exporting Pictures” on page 811.

To use Copy Region as Picture

1. Open the view that you would like to copy all or part of as a picture.
2. Select **Edit> Copy Region as Picture** . Your pointer displays a marquee  icon.

3. Click and drag a rectangular selection marquee around the desired region.
4. The selection is copied to the Windows clipboard.
 - If the current view is vector-based, the **Metafile Size** dialog displays because metafiles are better suited for line-based pictures. See “Metafiles” on page 814.
 - If the current view is a rendered view, the region is sent directly to the Windows clipboard.
5. From there, the picture can be pasted into another view or another program.

Walkthroughs



A 3D Walkthrough is a series of pictures saved as an **.avi** file that can be played like a video by other applications such as Windows Media Player.

There are two approaches to recording a walkthrough of a plan:

- Draw a path in floor plan view, then direct the program to record a walkthrough along that path.
- Create a 3D view, then begin recording and use the Move Camera tools to navigate through the view.



Create Walkthrough Path





There are several ways to record a walkthrough along a path, but the

Create Walkthrough Path tool is the fastest and most flexible option.

To create a Walkthrough Path

1. In floor plan view, select **3D> Walkthroughs> Create Walkthrough Path** , then click and drag to draw a Walkthrough Path. See “To use the Spline tool” on page 797.
2. Edit the direction and curvature of the spline’s segments, as needed. See “Editing Spline Based Objects” on page 144.
3. Add **Key Frames**  to the path and modify their specifications.

- Select the path and click the **Record Walkthrough Along Path**  edit button. See “Record Walkthrough Along Path” on page 821.

 Walkthrough Paths can follow stairs and ramps to span multiple floors. See “Walkthrough Paths and Stairs” on page 821.

You can also create a walkthrough based on a regular CAD polyline or spline by selecting it and clicking the **Record Walkthrough Along Path** edit button. This was the only way to record a walkthrough along a path in Home Designer Pro versions 8 through 2012 and does not provide as many options as using a Walkthrough Path.

In floor plan view, you can convert a CAD polyline or spline into a Walkthrough Path. See “Convert Polyline Dialog” on page 165.

Walkthrough Paths display in floor plan view when the “Walkthrough Paths” layer is turned on. When displayed, Walkthrough Paths display in front of other objects and will print. They are included in views sent to layout or exported to **.dxf**. See “Layers” on page 101.

Key Frames

 Key Frames are points along a Walkthrough Path that allow you to change:

- Camera direction, tilt angle, and height;
- Changes in walkthrough speed;
- The floor that the walkthrough is on.

These changes are applied as the camera moves along the Walkthrough Path from one Key Frame to another.

To add a Key Frame to a Walkthrough Path, select the path and click the **Add Key**

Frame  edit button. Then click on the path to add a Key Frame at that location.

In floor plan view, each Key Frame is represented by a camera symbol centered along the walkthrough path. It displays the frame number, is pointed in the direction of its **Camera Angle**, and its position along the path corresponds to the **Time** setting.

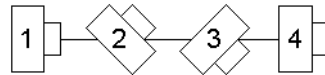

Key Frame positions and other properties can be edited in the **Walkthrough Path Specification** dialog. See “General Tab” on page 824.

You can also use the **Edit Key Frames**  edit tool to enable Move and Rotate edit handles for each Key Frame on the selected Walkthrough Path.

To use the Edit Key Frames edit tool

- Select a Walkthrough Path and click the **Edit Key Frames**  edit tool.
- Each Key Frame on the selected Walkthrough Path will display a Move and Rotate edit handle.
 - Click and drag the square Move handle to reposition the Key Frame along the path.

- Click and drag the rectangular Rotate handle to change the Key Frame's direction angle
3. When you are finished adjusting the Key Frames, click the **Main Edit Mode**  edit tool to restore the Walkthrough Path's normal edit handles.

Walkthrough Paths and Stairs

If you draw a Walkthrough Path up or down a staircase or ramp, it will follow the height of the stairs or ramp and continue on the next floor.

To create a multiple floor walkthrough

1. Draw a Walkthrough Path so that it extends into a staircase or ramp in the same direction as its Direction Arrow. See “Displaying Stairs, Ramps, and Landings” on page 402.
 - Do not drag the Walkthrough Path across the entire length of the stairs or ramp. If you do, its height will remain relative to the current floor.
2. When you release the mouse button, the program will automatically display a dashed line with an arrow extending past the last Key Frame on the current floor.
 - If it follows stairs or a ramp going upward, the path will also extend to the top end of the staircase or ramp.
3. Go up or down one floor, select the Walkthrough Path, and resize and reshape it as needed. You can use the **Create Walkthrough Path**  tool to draw more segments and additional Key Frames can be added, as well.

Record Walkthrough Along Path

Once a Walkthrough Path has been drawn, you can use it to record a walkthrough video.

Before recording a walkthrough, it is a good idea to choose a codec that will best suit your needs. See “Selecting a Codec” on page 823.

To record a walkthrough along a path

1. In floor plan view, select a Walkthrough Path or a CAD polyline or spline.
2. Click the **Record Walkthrough Along Path**  edit button or select **3D> Walkthroughs> Record Walkthrough Along Path** from the menu.
3. An Information message displays, reminding you that while a walkthrough is being recorded along a path, you should avoid using your computer.
4. In the **Save Video As** dialog, specify a name and saved location for your **.avi** walkthrough file. See “Exporting Files” on page 45.
5. In the **Walkthrough Options** dialog:

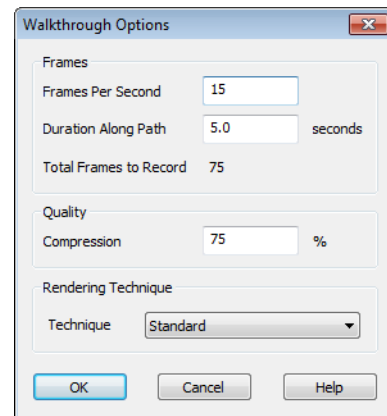

- Specify the desired number of **Frames Per Second**, between 1 and 100. A higher number results in a higher quality recording but also a larger **.avi** file.
- Specify a **Duration Along Path**, in seconds.
- The **Total Frames to Record** displays for reference and equals the Frames Per Second times the Duration along Path.
- Specify a **Compression** percentage between 0 and 100. A value of 0 gives the highest quality images and largest file sizes.
- From the drop-down list, select the **Rendering Technique** you would like the walkthrough to use. See “Rendering Techniques” on page 710.
- Click **OK**.

To cancel the recording as it is being created, press the ESC key on your keyboard.

Frame by Frame Walkthroughs

You can also create a walkthrough by recording it frame by frame. Although time-consuming, creating a walkthrough in this manner lets you see exactly what is being recorded as you record it.





As with walkthroughs recorded along paths, it is a good idea to select a codec that meets your needs before recording a walkthrough frame by frame. See “Selecting a Codec” on page 823.

To record a walkthrough frame by frame

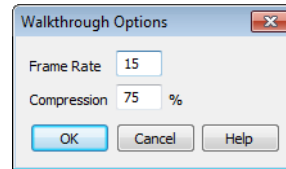
1. Create a camera view. This view is the first frame of the walkthrough.

2. From the view, select **3D > Walkthroughs > Record Walkthrough** .
3. Specify a location and name for the walkthrough in the **Save Video As** dialog and click **Save**.
4. In the **Walkthrough Options** dialog:



- Select a **Frame Rate** between 1 and 100. The value entered is the number of frames per second.
 - Select a **Compression Percent** between 0 and 100. A value of 0 gives the highest quality images and the largest file size.
 - Click **OK**.
5. Use the camera movement tools to create additional views. Each time the screen redraws, that view is recorded as the next frame in sequence. See “Editing 3D Views” on page 684.
 6. To move the camera without saving a view, select **3D > Walkthroughs > Pause Recording**  to temporarily stop recording.
 - You can then select **3D > Walkthroughs > Save Frame**  button to control what views are saved.
 - You can start recording again by selecting **Pause Recording**  once more.
 7. When the walkthrough sequence is complete, select **3D > Walkthroughs > Stop Recording**  or close the view.

Note: Zooming in and out and using the scroll bars does not change the viewpoint and does not produce a frame for the walkthrough.

If you resize the current view window while recording a walkthrough, the program will stop recording.

Playing a Walkthrough

Once a walkthrough has been recorded, it can be played on any media player.

To play a walkthrough

1. Select **3D> Walkthroughs> Play Walkthrough**  to open the **Select Video File** dialog.

2. Browse to an **.avi** file on saved on your computer. Your default video application plays the walkthrough video.

Selecting a Codec

A codec is a utility that compresses and decompresses media files, and is used when both recording and viewing **.avi** files such as walkthrough videos.

You can specify which codec to use when recording walkthroughs in the **Preferences** dialog. See “Render Panel” on page 86.

Before recording a walkthrough, it is a good idea to try each of the codecs installed on your system to see how well their walkthrough quality and file compression meet your needs.

Walkthrough Path Specification Dialog



Select a Walkthrough Path and click the **Open Object** edit button to open

the **Walkthrough Path Specification** dialog. See “Walkthroughs” on page 819.

General Tab

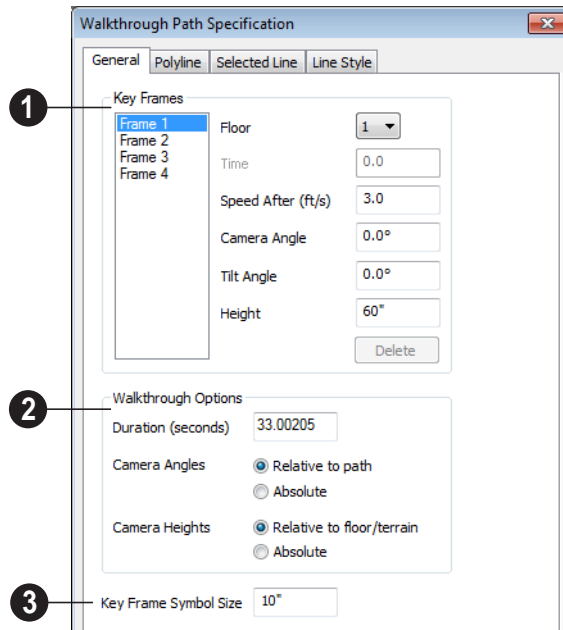

1 A list of the selected path's **Key Frames** displays on the left. Click on a Frame in the list to select and edit it using the settings on the right. When the dialog is opened, the last key frame edited in the current program session will be selected automatically. See “Key Frames” on page 820.

- Specify the **Floor** that the selected Key Frame is located on. See “Multiple Floors” on page 315.
- Specify the **Time** in seconds at which the selected Key Frame is found in the duration of the walkthrough. Frame 1 is always at 0.0 and cannot be moved; similarly, the last frame is always at the end of the walkthrough Duration.
- Specify the **Speed After (ft/s)**, which is how fast the camera moves along the

walkthrough path from the current Key Frame to the next. Not available if the last Key Frame is selected.

- Specify the **Camera Angle** at the selected Key Frame.
- Specify the **Tilt Angle** of the camera at the selected Key Frame.
- Specify the **Height** of the camera at the selected Key Frame.
- Click the **Delete** button to remove the selected Key Frame from the path.

2 Walkthrough Options -

- Specify the **Duration**, or total length of the walkthrough video in seconds.

Specify how **Camera Angles** are measured:

- Select **Relative to path** to measure each camera angle relative to the direction of the walkthrough path at each Key Frame location.
- Select **Absolute** to measure each camera angle relative to the plan's X, Y, and Z axes. See "3D Drafting" on page 25.

Note: When Relative Angles are used, a Camera Angle of 0° points in the direction of the walkthrough path. When Absolute Angles are used, 0° always points in the positive direction along the X axis.

Specify how **Camera Height** is measured:

- Select **Relative to floor/terrain** to measure camera height relative to the floor or terrain at each Key Frame location.
 - Select **Absolute** to measure camera height relative to the plan's Z axis.
- 3** Specify the **Key Frame Symbol Size**, which is the size of the symbols representing the selected walkthrough path's Key Frames in floor plan view. See "Key Frames" on page 820.

By default, Key Frames use the **Camera Symbol Size** set in the **Camera Defaults** dialog. See "Camera Defaults Dialog" on page 665.

Polyline Tab

The Polyline tab indicates the path's **Length/Perimeter**. The **Area** and **Volume** of a walkthrough path will always be described as "Not closed". See "Polyline Tab" on page 792.

Selected Line Tab

The Selected Line tab is available when the selected path edge is a line as opposed to an arc. See "Selected Edge" on page 125.

Moving the Start of a line segment moves the end of the previous connected line, if there is one. Similarly, moving the End of a line segment moves the start of the next connected line, if there is one.

This tab is similar to the Line tab of the **Line Specification** dialog. See "Line Tab" on page 780.

Selected Arc Tab

The Selected Arc tab is available when the selected path edge is an arc as opposed to a line. See "Change Line/Arc" on page 159.

This tab is similar to the Arc tab of the **Arc Specification** dialog. See "Arc Tab" on page 787.

Spline Tab

The Spline tab has a single option and is only available if the selected walkthrough path is a spline. See "Splines" on page 796.

The image shows a small rectangular dialog box with the title "New Segment Angle". Inside the box is a text input field containing the value "5.0°".

New Segment Angle - Specify the angle between line segments that are used to draw the spline. Specifying a smaller angle makes the spline's curvature smoother.

Line Style Tab

This tab is similar to the Line Style tab in the **Line Specification** dialog. See “Line Style Tab” on page 781.

Importing & Exporting

Importing is the process of opening a file that was produced in a different program in Home Designer Pro. Exporting, on the other hand, is the process of saving information in a Home Designer Pro file to a format that can be read by another program.

Home Designer Pro allows you to import and export a variety of information from and to other applications. This chapter focuses on importing and exporting 2D .dxf files and a variety of 3D file formats.

There are numerous other options for importing objects and data in Home Designer Pro. They are discussed in the chapters in which those objects or settings are discussed.

Chapter Contents

- DXF File Format
- Importing 2D Drawings
- Import Drawing Wizard
- CAD to Walls
- Exporting 2D DXF Files
- Additional 2D Export Information
- 3D Data Import Requirements
- Importing 3D Symbols
- 3D Symbols and Materials

DXF File Format

.dxf (Drawing eXchange Format) is a standard file format created by Autodesk for the transfer of data between other programs.

Many design programs can read and write **.dxf** files. The **.dxf** file format interprets data as CAD objects such as lines, polylines, and circles.

Importing 2D Drawings

2D drawings are imported by reading entities from a **.dxf** file and creating the equivalent CAD objects in Home Designer Pro.

Home Designer Pro 2014 can import 2D **.dxf** files compatible with AutoCAD® through version 2012.

Only drawings created in AutoCAD®'s Model Space can be imported into Home Designer Pro. Entities drawn in Paper Space are not recognized.

A **.dxf** file can be imported into floor plan view, a Wall Elevation or Cross Section/Elevation view.

In general, all Z coordinates are mapped to zero. If an entity in an imported drawing has thickness, Home Designer Pro ignores it.

Supported Entities

The following is a list of the entities that are imported and how they are converted. All other entities are ignored:

- **Lines** - Both 2D and 3D lines.
- **Circles** - Fully supported in 2D.
- **Arcs** - Fully supported in 2D.

- **Ellipses** - Fully supported in 2D.
- **Spline entities** - Fully supported as 2D polylines.
- **Polylines and Lightweight Polylines** - Polylines are imported as polylines. Bumps are converted to arcs. Line widths are ignored.
- **Lightweight Polylines** - Fully supported in 2D.
- **Text & Multi-line Text** - Both are imported as Rich Text and mapped to the Text layer. Multi-line text objects retain their original width. The first font in a multi-line text object is applied to the entire object. If that font is unavailable, Arial is used.
- **Unicode Text** - Fully supported.
- **Blocks & Block Inserts** - A block is a named group of CAD entities that have been joined together to behave as a single object. A block insert is a reference to such a block. Blocks are loaded by name. If a duplicate name is found, you can specify whether a block is imported under a new name, replaces an existing block or simply uses the existing block of the same name.

Note: Blocks imported into Home Designer Pro cannot be exploded into their individual component objects.

- **Hatch entities** - If **Import Hatch entities** is selected on the Select File page of the **Import Drawing Wizard**, Hatch patterns are imported as a CAD block consisting of solid black filled polylines.
- **2D Solids** (Not ACIS Solids) - Fully supported in 2D.
- **Solids** - A solid is a 3 or 4-sided filled area. These are imported as 2D faces.
- 2D Solids (Not ACIS Solids)
- **3D Faces/Polyface Meshes** - A 3D face has its Z coordinate mapped to zero, and imports as a polyline.
- **Dimensions** - Rotated, aligned and 3-point angular dimensions are supported.

All other dimension types are imported as lines and text rather than functioning dimensions.

- **Attributes** - Attributes are text objects associated with other items, like blocks. These are imported as text objects at the appropriate location but the association with the original object is broken.
- **Line Styles** - Line styles are not imported. Instead, if a style of the same name displays in the Home Designer Pro line styles, that line style is used. Otherwise a solid line style is used.
- **Layers** - You can specify which layers in the imported drawing to import into your Home Designer Pro file. You can also choose how you wish to map drawing layers to layers in the destination file. See “Layers” on page 101.

Import Drawing Wizard



A **.dxf** file can be imported into floor plan view, a **Wall Elevation** or **Cross Section/Elevation** view.

To import a 2D drawing file, open the view window in which you would like to place the drawing and select **File> Import> Drawing**

(DXF)  to open the welcome page of the

Import Drawing Wizard. Click **Next** to continue.

You can also launch the **Import Drawing Wizard** by dragging a **.dxf** file from a Windows Explorer window into the Home Designer Pro window.

Select File

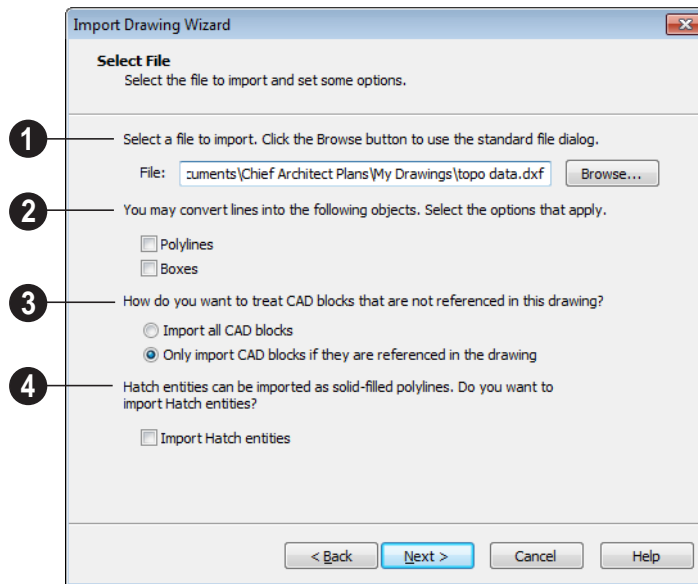

1 Type the full pathname of the drawing file you want to import or click the **Browse** button to locate a file on your computer. The directory containing the last file selected using the **Import Drawing Wizard** displays in this field.

2 If you want to convert lines to polylines or boxes, check the appropriate options. Polylines are imported as polylines regardless of these settings.

- Check **Polylines** to import lines as polylines. Unconnected lines will be connected.
- Check **Boxes** to import lines as boxes. Unconnected lines will be connected.

3 Specify how to treat CAD blocks associated with the selected drawing.

- Select **Import all CAD blocks** to include all CAD blocks associated with the file being imported whether or not they are visible.
- Select **Only import CAD blocks if they are referenced in the drawing** to reduce the volume of transferred data.

4 Check **Import Hatch entities** to import areas of hatching as solid-filled polylines.

Click **Next** to load the file into memory so that Home Designer Pro can present information about the contents of the file. This can take a while for larger files.

Select Layers

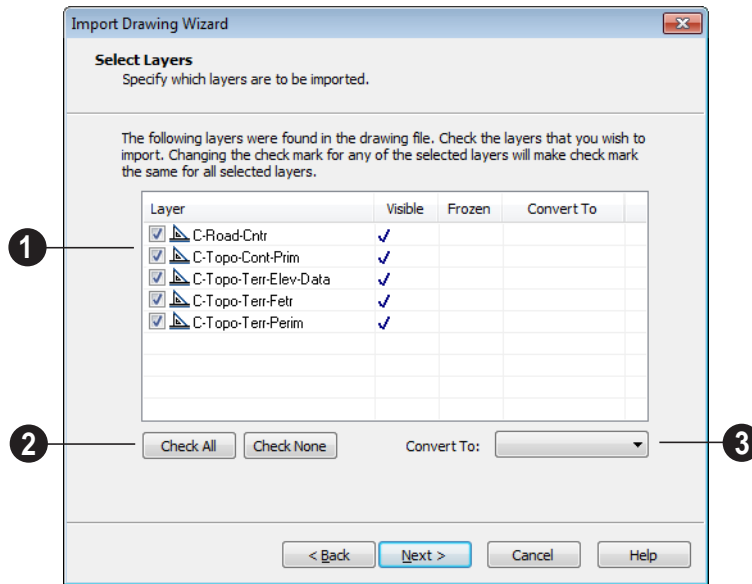

- 1 A list of the layers found in the imported file and information about each layer displays in this table.
 - In the **Layer** column, check the box to the left of each layer name to specify which layers you want to import. Layers with checked boxes are imported; those with unchecked boxes are not.
 - Layers that were **Visible** in the original program are checked by default. You can include a layer that is not visible by checking the box to the left of its name.
 - Layers that were **Frozen** in the original program are not checked by default. You can include a frozen layer by checking the box to its left.
 - If a layer is set to **Convert To** a terrain perimeter or elevation data, it will be indi-

cated in this column provided that you are importing into floor plan view.

- 2 Click **Check All** to import all layers associated with the drawing. Click **Check None** to import none of the layers.
- 3 The **Convert To** drop-down list allows you convert the data on any layer into a “Terrain Perimeter” or “Elevation Data”. See “Terrain Perimeter” on page 538 and “Importing DXF Elevation Data” on page 572. Only available when importing into floor plan view.

To convert a layer to terrain data, click on the layer in question in the table and then select an option from the **Convert To** drop-down list. The option you choose will then display in the **Convert To** column in the table.

Note: if an open polyline is converted into a Terrain Perimeter, the program will draw an additional edge to close the gap.

Drawing Unit

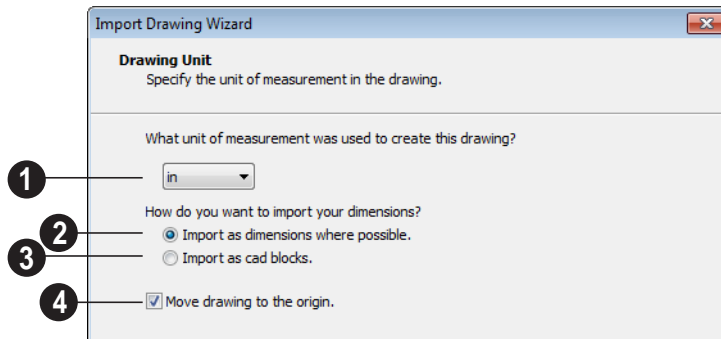

- 1 **What unit of measurement was used to create this drawing?** - Select a unit of measurement from the drop-down list. Selecting the correct unit helps ensure that your imported drawing is accurately sized.

Note: During the import process, Home Designer Pro defaults to inches or millimeters. If you are importing a site plan or topo prepared by a surveyor, or if you are importing a metric drawing into an imperial plan (or vice versa), you may need to change units.

If the file being imported was drawn at a scale other than 1:1, you can compensate for this scaling by creating a custom unit of measurement and specifying it here. See “Unit Conversions Panel” on page 71.

- 2 Select **Import as dimensions where possible** to import dimensions as Home Designer Pro supported dimensions.
- 3 Select **Import as CAD blocks** to import dimensions as CAD entities that

are not recognized by Home Designer Pro as dimensions.

- 4 Check **Move drawing to the origin** to place the drawing at 0,0. When unchecked, it is imported to the same location as it was drawn in the original application. See “3D Drafting” on page 25.

Import Complete

When a file is imported into Home Designer Pro, its various components are selected as a group. The group-selection has Move and Rotate edit handles available for relocating the entire drawing. Once another object or tool is selected, the drawing components are no longer group-selected.

Imported drawings are assigned the same coordinates at which they were originally drawn. If you do not see your imported drawing, select **Window > Fill Window** , as it may have been placed at a location not currently visible on screen.

When the drawing can be seen, move your mouse pointer over it and note its coordinates in the Status Bar. If any coordinate value has more than six digits, use the **Transform/**

Replicate Object  edit button to move it

closer to the origin. See “Transform/Replicate Object Dialog” on page 166.

Imported CAD objects can be selected and edited just like objects that were drawn in the program. See “Editing Objects” on page 119.

CAD to Walls



This feature allows you to convert a flat line drawing into a 3D model. Once a drawing has been imported into Home Designer Pro, CAD lines that

represent wall layers and other structural items can be converted to actual Home Designer Pro walls or railings. See “CAD to Walls” on page 208.

Exporting 2D DXF Files

Line-based 2D files can be exported from Home Designer Pro in **.dxf** file format. You can specify the version of AutoCAD® to export to. Compatibility with other software may vary.

There are two ways to export a 2D drawing file in Home Designer Pro: Export Current View and Export All Floors.

Export Current View



To export a floor plan view or Vector View that is currently active, select **File> Export> Current View (DXF)**.

Bear in mind that Orthographic views are drawn to scale and will produce a 2D drawing that can be accurately dimensioned. Perspective views, on the other hand, are not scaled and do not produce drawings that can be dimensioned accurately. See “Perspective and Orthographic Views” on page 664.

Bear in mind that Orthographic are drawn to scale and will produce a 2D drawing that can be accurately dimensioned. Perspective views, on the other hand, are not scaled and do not produce drawings that can be dimensioned accurately. See “Perspective and Orthographic Views” on page 664.

Export All Floors



To export the floor plan view for all floor plans simultaneously, select **File> Export> All Floors (DXF)** from any floor of the plan. The floor plans are exported to a single **.dxf** file.

If you choose to export all floors, the file will contain all floors superimposed on each other. Upon export, each layer in your Home Designer Pro drawing is divided into separate layers: one for each floor. For example: “Electrical-2” contains objects on Floor 2 that were originally on the “Electrical” layer.

Export Drawing File Dialog

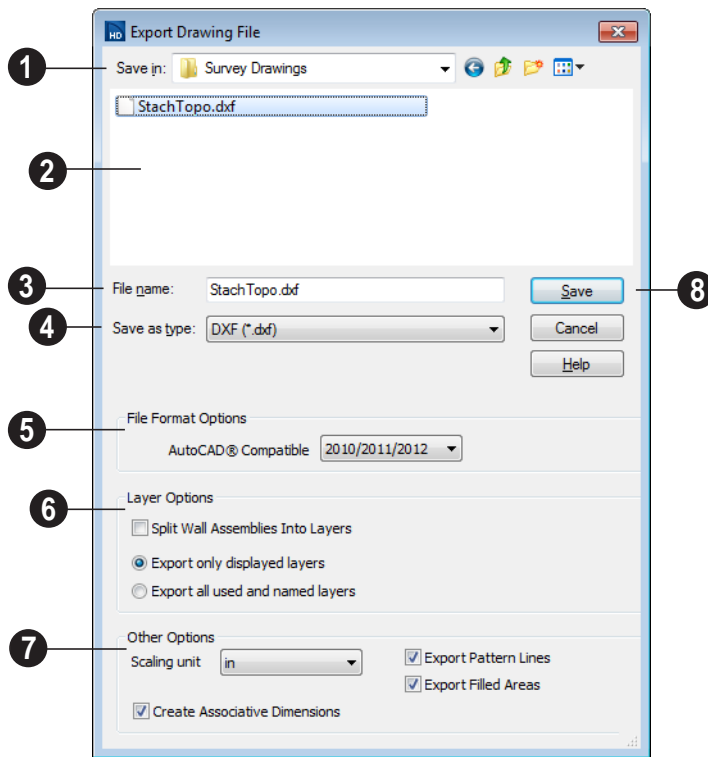

1 Save In - The current directory displays here. Click the drop-down arrow and browse to the export location you prefer.

2 Existing **.dxf** files in the current directory are listed here.

3 Enter a **File name**.

4 Save as type - Home Designer Pro will use the **.dxf** format to export.

5 File Format Options - **.dxf** files created by Chief Architect can be compatible with a variety of AutoCAD®

versions. Specify which version from the drop-down list.

6 The **Layer Options** settings allow you to control the layers associated with the file being exported. See “Layers” on page 101.

- **Split Wall Assemblies Into Layers** - Wall assemblies can be split into layers, allowing them to be edited separately.
- Select **Export only displayed layers** to export only those layers that are displayed on screen. This is what always occurs when exporting from layout, but is not an available option in layout files.

- Select **Export all used and named layers** to export all layers that either have something on them or have a layer name specified. Not available in layout files.

7 Other Options

- **Scaling Unit** - Select the unit of measurement to be used. For best results, choose inches or feet for Imperial plan or layout files, or metric units for metric files. See “Dimension Preferences and Defaults” on page 719.
- Uncheck **Create Associative Dimensions** to export dimensions as simple CAD entities that are not recognized dimensions by other programs. Associative dimensions are recognized by AutoCAD® and many other CAD programs.

When exporting a layout page, it is often best to uncheck this box.

- Check **Export Pattern Lines** to export pattern lines. Pattern lines are exported as normal CAD lines.
- Check **Export Filled Areas** to export filled areas as AutoCAD® 2D solid entities.

Dimension lines using non-default formatting will lose their changes and will use the default format upon export.

- 8 When you are satisfied with your selections, click **Save** to export the file as specified.

The file is now ready to be opened by or imported into another program.

Additional 2D Export Information

The export process converts high level Home Designer Pro objects (doors, windows, etc) into simple, CAD-based objects (lines, arcs, etc). Home Designer Pro exports all data to AutoCAD®’s Model Space.

Supported Entities

The following entity types are currently supported for 2D export:

Line - The simplest entity. In AutoCAD®, lines are 3 dimensional with the Z coordinate set to zero.

Arc - Arcs have a start angle, end angle and radius.

Circle - Fully Supported.

Multi Line Text - If exporting to an AutoCAD® release that supports multi-line text, Home Designer Pro writes the file as multi-line text. If exporting to a version that does not support multi-line text, the file is written as simple text.

Unicode Text - Fully supported.

Polylines - Polylines are a collection of points with lines or arcs connecting them. Home Designer Pro supports both lines and arcs. Arcs are referred to as bulges in AutoCAD®.

Block Insert - A block insert is a reference to a block, which is a named collection of entities. A block can also contain block inserts.

Dimensions

Aligned, rotated, and angular dimensions can all be exported.

Each dimension has an associated block containing a representation of the dimension as it is drawn in Home Designer Pro. It also contains all the data to recreate that information.

- When an exported dimension is modified in AutoCAD® or other CAD program, its appearance changes.
- Home Designer Pro does not support arrowhead styles or fonts.
- Three kinds of dimensions are generated: Aligned, Rotated and 3 Point Angular.
- Please refer to AutoCAD® documentation for more information.

Note: Uncheck "Use Associative Dimensions" in the Export Drawing File dialog if the CAD program you are using does not support AutoCAD® Associative dimensions. See "Export Drawing File Dialog" on page 834.

Line Types

A line type, or line style, is used by layers and entities to determine how lines are

drawn. Home Designer Pro line types installed with the program are supported on export.

Layers

Layers in other systems are similar to Home Designer Pro layers, but there are some subtle differences. Layer information is mapped as follows:

Home Designer Pro	Other Systems
Name	Name
Color	Nearest AutoCAD® Color. Home Designer Pro uses the default AutoCAD® color table to determine this mapping.
Display	On
Size	Line Weight. In AutoCAD®, line weights are determined by a table of mm line widths. Home Designer Pro maps to the closest match in the default line weight table based the current view's Line Weight Scale. See "Page Setup Dialog" on page 853.
Style	Line type
Lock	Lock

3D Data Import Requirements

Importing a symbol that can be used by Home Designer Pro is a relatively simple process that begins with previously created 3D data. This 3D data often comes from a program other than Home Designer Pro. If you use another 3D modeling program to create the 3D data, be aware of the following

requirements before attempting to create symbols.



Home Designer Pro is not able to provide support for any third party software.

There are a number of requirements that must be met before any 3D data can be used to create a symbol in Home Designer Pro:

- The 3D data must be stored in a standard Drawing Exchange File (**.dxf**), object (**.obj**), 3D Studio Mesh (**.3ds**) or SketchUp version 8 and prior (**.skp**) file format. If you have 3D data in another format, you must convert it into one these formats first.
- Geometry and material information stored in **.3ds** files are imported; cameras and lights are not.
- The 3D model must be composed of 3DSOLID solid entities, or face data. Faces are typically referred to as 3D faces, polygonal faces, or poly meshes. Other types of entities such as lines, curves, circles, polylines, and free form surfaces can exist in the file but are not imported when the symbol is created. This is true for all (**.dxf/.obj/.3ds/.skp**) file types.
- The face data should be assigned to different layers so that you can map them to the correct materials when viewing them in 3D. It is helpful to name your layers using a convention that identifies that materials should be assigned to each sub-component.
- Pay attention to the origin and orientation of the 3D data when designing symbols. Home Designer Pro allows some adjustment when creating the symbol, but it is easier to build the 3D data correctly before importing it into Home Designer Pro. For more information about defining the origin, see “Symbol Origin” on page 54.

- Home Designer Pro does not support grouped objects in symbols imported from **.3ds** files.

Surface Normals

If you use third party software to create a **.dxf/.obj/.3ds/.skp** files that will be imported as a symbol, you should be familiar with the concept of surface normals.

If you use third party software to create a **.dxf/.obj/.3ds/.skp** file that will be imported as a symbol, you should be familiar with the concept of surface normals.



A surface normal is a vector that is perpendicular to the plane of a surface. This vector points in one direction, determined by the way the face is drawn.

If a face is drawn clockwise, the surface normals are directed outward; if a face is drawn counter-clockwise, the surface normals point inward. Home Designer Pro assumes that the face on the positive side of the normal vector is the outside face.

Many objects can be drawn using only one side of each face. A cube is a good example: the inside of a cube is not visible, so it is not necessary to create its inside faces. When inside faces are not calculated, 3D views in Home Designer Pro can generate more quickly.

Importing 3D Symbols



Home Designer Pro supports the import of 3D surface and 3D solid objects saved to **.dxf**, **.3ds**, **.obj**, and **.skp** formats.

There are two ways to import a 3D symbol into Home Designer Pro:

- By dragging and dropping the file from Windows Explorer into floor plan view.
- Using the **Import 3D Symbol** dialog.

Symbols imported by clicking and dragging are imported for use in the current plan, while those imported using the **Import 3D Symbol** dialog are also saved in the library. See “The Library” on page 603.

To drag and drop a 3D symbol

1. Open the plan in which you would like to import a 3D symbol and remain in floor plan view.
2. Open a Windows Explorer window in front of the Home Designer Pro program window.
3. If the Explorer window fills your screen, click the Restore Down button at the top right and resize the window so that the

Home Designer Pro program window can be seen behind it.

4. Click on the desired **.3ds**, **.obj** or **.skp** file and drag it into the Home Designer Pro program window.
5. When your cursor changes to a **+**, click in the drawing area to place as many copies of the symbol as desired. When you are finished, select a different tool.

Import 3D Symbol Dialog



Select **File> Import> 3D Symbol** to open the **Import 3D Symbol** dialog.

The **Import 3D Symbol** dialog is a typical **Open File** dialog. See “Importing Files” on page 49

Home Designer Pro supports the import of 3D surface and 3D solid objects saved to **.3ds**, **.obj** and **.skp** formats. Home Designer Pro treats imported symbols as stand alone fixtures.

Note: SKP files are always imported using inches, regardless of the default units used in the plan file. See “Creating a New Plan or Layout” on page 42.

3D Symbols and Materials

When a symbol is imported into Home Designer Pro, material definitions may be included with it. Whether and how material information is included depends on the symbol’s file format. See “About Materials” on page 632.

DXF Files

.dxf files do not include information about material definitions. If the **.dxf** file associated with a symbol is changed, all previously specified material information for the symbol will be lost.

All layers, layer names, solids and instances of blocked solids from the **.dxf** file display in the list on the left side of the Materials window.

OBJ Files

Material definitions for most **.obj** files are saved in a separate file with the **.mtl** file extension. If such a file exists, the materials associated with the **.obj** file display in the list on the left side of the Materials window.

If Home Designer Pro does not receive material definition information in an accompanying **.mtl** file, default material properties are assigned.

Material definitions for **.obj** files can also include texture information in the form of image files (**.jpg**, **.png**, etc).

In order to properly import an **.obj** file, Home Designer Pro needs the **.obj** file, the **.mtl** file, and any referenced texture files. If a texture file is not available, the material it is associated with is created without a texture.

The material definitions associated with an imported **.obj** symbol are not available for

use by other objects in Home Designer Pro until that symbol has been placed into a plan. The associated texture files are then copied to the user's Textures folder. See "Home Designer Pro Data" on page 41.

3DS Files

Material definitions for **.3ds** files refer to texture information in separate image files.

In order to properly import a **.3ds** file, Home Designer Pro needs these referenced image files. If a texture file is not available, the material it is associated with will be created without it. The associated texture files are copied to the user's Textures folder.

SKP Files

The textures associated with a **.skp** file are saved in the file. After you import a symbol and either place it in a plan or add it to the Library, these textures are saved in the Home Designer Pro Textures folder.

Home Designer Pro does not support deformed textures. If a texture associated with a **.skp** file is deformed, it will be imported without the deformations.

Texture Filename Conflict

If a texture of the same name already exists in the plan when an **.obj**, **.3ds** or **.skp** file is

imported, the **Texture Filename Conflict** dialog displays.

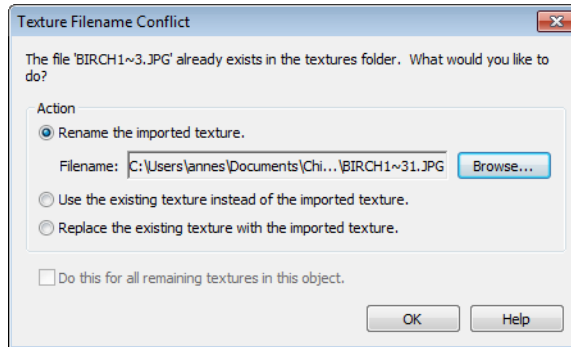

- Select **Rename the imported texture**, then click the **Browse** button to create a copy of the texture's image file with a new name that you specify.
- Select **Use the existing texture instead of the imported texture** to keep the existing texture.
- Select **Replace the existing texture with the imported texture** to replace the texture already present in the plan with the new, imported one.
- Check **Do this for all remaining textures in this object** to use the same selection for all textures with filename conflicts associated with this symbol.

Printing & Plotting

Home Designer Pro provides a variety of printing options, from printing plan and 3D views to a set of templates that can be assembled into a 3D model.

To create working drawings, you can use the program's Layout facility. Multiple views of the model can be arranged on pages along with a border and title block. For more information, see "Layout" on page 863.

Home Designer Pro also allows you to save your drawings in electronic file formats that can then be sent to a printing service.



Screen captures are provided for illustrative purposes only and are not an endorsement of any products.

Chapter Contents

- Introduction to Printing
- Printers and Plotters
- The Printing Tools
- Display Options and Printing
- Printing Directly from a View
- Printing from Layout
- Printing to Scale
- Printing Across Multiple Pages
- Printing to a PDF File
- Line Weights
- Printing Text and Dimensions
- Creating Custom Sheet Sizes
- Page Setup Dialog
- Print Dialog
- Print Image Dialog
- Print Model

Introduction to Printing

Home Designer Pro offers printing options to suit a variety of needs. You will benefit from understanding the output options clearly and choosing the one that makes the most sense for the project at hand.

Output Options

Printing From Layout - For professional quality drawings and details, printing from layout provides the most control and the best results. For more information, see “Layout” on page 863.

Printing Directly From a View - For individual drawings, you may prefer to print directly from a view. The process is quick and allows control over scaling, positioning, and line weights, depending on the view type. See “Printing Directly from a View” on page 846.

Printing to a Remote Plotter/Printer - Plans can be printed to a .pdf file and printed remotely. See “Printing to a PDF File” on page 848.

Print Model - If your final printed output will be used to create a 3D model of your design, the Print Model feature works best. See “Print Model” on page 858.

Terminology

There are a few terms that you should familiarize yourself with.

Sheet Size - The dimensions of the final printed output. This may or may not be the same as the printer paper size. If the sheet size and paper size are the same, only one

page is required per sheet. See “Page Setup Dialog” on page 853.

Paper Size - The dimensions of the paper to be printed on. Specifying a paper size that is smaller than the Sheet Size allows large drawings to be printed across multiple pages.

The preview diagram in the **Page Setup** dialog illustrates the difference between page size and drawing sheet size. See “Page Setup Dialog” on page 853.

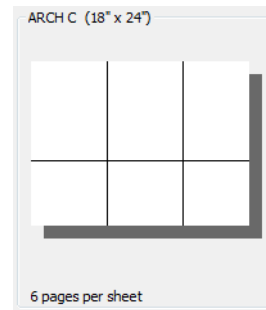

When a Printer Paper size of Letter (8½" x 11") is selected, 8 pages are required to fill an Architectural C Drawing Sheet size (18" x 24").

Check Plot - A test printing, typically at a smaller scale, made before final output to large paper format. For more information, see “Check Plots” on page 847.

Line Weight - The thickness of a line. A thicker line weight is easier to see, but may not show as much detail. See “Line Weights” on page 849.

Printing Scale - Drawings are often printed to scale for accuracy. ¼" = 1' and 1 m = 50 m are examples of common scales. Home Designer Pro prints to a scale of 1/4" = 1' by default, although this scale can be changed in the **Page Setup** dialog. See “Page Setup Dialog” on page 853.

When a particular scale is not important, drawings can also be sized to fill a particular area. See “Printing to Scale” on page 847.

Printing Problems

Home Designer Pro can print to almost any printer or plotter that supports printing graphics from Windows programs. If you

encounter difficulties when trying to print, see “Troubleshooting Common Technical Issues” on page 910.



Always familiarize yourself with your printer or plotter before a deadline is near, and bear in mind that it can take a little time to configure a new printer.

Printers and Plotters

There are many different types of printers and plotters. In general, a printer is smaller, normally outputting 8½ x 11" (Letter or ANSI A size), 8½ x 14" (Legal Size) or sometimes as large as 11 x 17" (Tabloid or ANSI B size).

Plotters are typically used to output larger sheets of paper such as 17 x 22" (ANSI C), 22 x 34" (ANSI D) or 34 x 44" (ANSI E). Printing to pen plotters is not supported.

Printer Drivers

Printer drivers are programs that interpret between software programs and the printer. The drivers are usually created by the manufacturer of the printer and are typically updated regularly. Different drivers are used for different versions of Windows.

It is useful to keep track of the drivers for each printer or plotter you use and update them whenever the Windows operating system is updated or replaced.

Note: You should only update your printer driver if you are having problems printing.

To find the version of your printer driver, select **Start> Control Panel> Printers and Faxes** to view the Printers information for Windows. Select the printer in question, then choose **File> Properties**.

In most **Printer Properties** dialogs is an **About** button which you can click to find the version and creation date of the driver currently in use. If you experience printing problems and yours is not the latest driver, consider replacing it with an updated driver. Visit your printer manufacturer’s Web site for more information.

Windows provides information about installing printer drivers. To access Windows Help, select **Start> Help**. If you have problems installing a driver, refer to your printer documentation for technical support.



Options available with one driver may not be available with another. Printers and plotters supported in one version of Windows may not be supported by the manufacturer in another.

Clearing Printer Information

Some information specific to individual printers and plotters, such as available paper

sizes, is saved with each plan and layout file. You can select **File> Print> Clear Printer Info** to clear the printer-specific information stored with the plan or layout file.

The Printing Tools



Select **File> Print** to view the Print Tools submenu.



Page Setup - Opens the **Page Setup** dialog, where printing options are set. See “Page Setup Dialog” on page 853.



Scale to Fit - Automatically selects a scale that fits your plan to the drawing sheet. See “Printing to Scale” on page 847.



Center Sheet - Automatically centers your drawing on the sheet. See “Center Sheet” on page 846.



Print Preview - Shows how the current view will appear when printed. See “Print Preview” on page 845.



Print - Prints the current floor plan view, Vector View, or layout sheet. See “Print Dialog” on page 855.



Print Image - Prints a screen view including images, textures and backdrops. See “Print Image Dialog” on page 857.



Print Model - Opens the **Print Model** dialog, allowing you to print templates

for making a physical model of your plan. See “Print Model” on page 858.

Customize Sheet Sizes - Allows you to create custom sheet sizes. See “Creating Custom Sheet Sizes” on page 852.

Clear Printer Info - Clears the printer information associated with the current page setup.

Toggle Buttons

Toggle buttons are either on or off. When on, they appear depressed and remain depressed until clicked again. See “Toolbar Configurations” on page 98.



Show Line Weights - When this is on, line weights appear on screen as they will print. See “Show Line Weights” on page 845.



Show Sheet - Turn this toggle on for a preview of your plan relative to the current sheet size. See “Show Sheet” on page 845.

Display Options and Printing

The display of objects in views can be used to affect the printed output. Some display options allow you to preview the printed output on screen before any paper is used.

Objects must be visible in order for them to print; but not all items that are visible print.

- Camera symbols in floor plan view, CAD points, and the snap and reference grids, for example, do not print.
- The Reference Display does print if it is visible. See “Reference Display” on page 327.



To see how your printed output will appear on paper, select File> Print> Print Preview or click the **Print Preview** toggle button.

Displaying Objects



You can control the display of objects when printing directly from a view in the **Layer Display Options** dialog. See “Layer Display Options Dialog” on page 104.

To control the display of objects in an orthogonal view sent to layout, select the view, click the **Layout Box Layers** edit button, and make any needed changes in the **Layer Display Options** dialog.

To control the display of objects in a camera view sent to layout, turn layers on/off in the view before it is sent to layout.

Show Line Weights



Select **Tools> Display Settings> Show Line Weights** for an on-screen representation of line weights and line styles. Turning **Show Line Weights** on or off does not affect the final printed output.

When **Show Line Weights** is turned on, you can **Zoom In**  to see the location of lines and dashed lines as they will appear on the printed page.

When **Show Line Weights** is off, dashed lines look the same, regardless of the zoom factor.



Show Line Weights can also be turned on or off in the **Preferences** dialog. See “Appearance Panel” on page 61.

Print Preview



Select **File> Print> Print Preview** for an on-screen representation of how the current view will appear when printed. Print Preview is only available in views that can be scaled. See “Printing to Scale” on page 847.

Objects such as camera symbols that do not print do not display in **Print Preview** . Text and dimension objects appear on-screen as they will on the printed page.

When **Print Preview**  is on the drawing sheet and line weights are displayed, and the toggle buttons **Show Sheet**  and **Show Line Weights**  are overridden.

Show Sheet



Select **Tools> Display Settings> Show Sheet** to show the drawing sheet on screen. The drawing sheet size is specified in the **Page Setup** dialog. See “Page Setup Dialog” on page 853.

Any portion of your plan that cannot fit on the drawing sheet at the current scale displays outside the sheet.

A blue border represents the printable area, which varies depending on which printer is currently selected. This border may not

display on all edges of the drawing sheet. See “Printer Drivers” on page 843.

When **Show Sheet**  is on, the drawing sheet behaves as an object.

- When selected at its border the sheet has edit handles, allowing it to be moved. See “Editing Objects” on page 119.
- You can also resize the sheet using its edit handles; however, for best results, it is recommended that you instead select an available sheet size in the **Page Setup** dialog. See “Page Setup Dialog” on page 853.
- Dimension lines locate the borders of the sheet. These dimensions can be used to relocate other objects in relation to the

sheet. See “Moving Objects Using Dimensions” on page 737.



Note: Specifying a standard sheet size in the Page Setup dialog is preferable to editing the sheet size on-screen.

The drawing sheet cannot be rotated or copied.

Center Sheet





Select **File> Print> Center Sheet** to center the drawing sheet on the drawing. This moves the sheet relative to the drawing but does not affect the coordinates of objects in the drawing. The location of the drawing sheet is independent for each floor of the model.

Printing Directly from a View



To print directly from any floor plan view or cross section/elevation view, choose **File> Print> Print**. See “Print Dialog” on page 855.

To set up print formatting before printing, select **File> Print> Page Setup** . See “Page Setup Dialog” on page 853.

Rendered 3D views can be printed using **File> Print> Print Image** . See “Print Image Dialog” on page 857.

Printing from Layout

Home Designer Pro layout files can be used to print professional working drawings. Multiple views at different scales can be sent to each sheet and organized as desired.

Layout sheets can accommodate a border and title block and can be printed at full size or printed at a smaller scale for check plots. See “Layout” on page 863.

Printing to Scale

Several different print scaling options are available. The type of view that you are printing determines which options you may choose from.

Orthogonal Views

Floor plan views, Orthographic 3D views, and layout pages are orthogonal views, which means:

- Your line of sight is at a right angle to all objects in the view.
- Objects do not appear to decrease in size as their distances from the viewer increase.

Orthogonal views can be printed to scale; however, Orthographic 3D views can only be printed to scale when the Vector View Rendering Technique is used.

The scale set in the **Page Setup** dialog is inherited by the **Print** and **Send to Layout** dialogs. This scale can be overridden on an individual basis in either of these dialogs. See “Print Dialog” on page 855 and “Sending Views to Layout” on page 866.

Select **File > Print > Scale to Fit**  in an orthogonal view to select a suitable scale and re-center the drawing sheet so that everything fits on the sheet.

Imperial drawing scales are typically noted in inches per foot. Larger scales, such as 1 inch = 50 feet or 1:200m, are often used for property layouts.

Perspective Views

Camera views and Perspective overviews display the model much the way the eye would see it and cannot be scaled.

- Objects in the view may be at any angle relative to your line of sight.
- Objects seem to decrease in size as their distances from the viewer increase.

Perspective views can only be printed using the **Print Image**  tool. See “Print Image Dialog” on page 857.

While perspective views cannot be scaled, you can control the printed size of the view. If **Fit to Paper** is selected in the **Print** dialog, a percent value can be set that defines how much of the printed page to fill. See “Print Dialog” on page 855. 50% causes the print to be 50% of both the height and width of the paper, including the non-printable border.

For example, if printing to an 8½ x 11 page with a 1" non-printable border in each direction:

- 100% would print an area 8½ x 11. This is not recommended, as part of the output could fall outside the printable area.
- 50% would print an area 4¼ x 5½.
- Each printer may vary slightly.



Check Plots

A check plot is a test print that allows you to print at a reduced scale on smaller, less expensive paper so you can check that the drawing will print as expected.

In a check plot, the drawing scale is temporarily adjusted to a specified fraction of its true value. Both drawing scale and line weights are subject to this scale adjustment.

For example, if a layout has a Drawing Scale of 1/4" = 1' and a Drawing Sheet of 24" x 36", a check plot at 1/2 scale would result in a printed drawing scaled at 1/8" = 1', which would fit on a 12" x 18" page.

To create a check plot



1. Select **File> Print> Page Setup** . In the **Page Setup** dialog:
 - Confirm that the **Drawing Sheet Size** and **Drawing Scale** are correct for a full size print out - not a check plot.
 - Specify the **Printer Paper Size** that you would like to use for the check plot, then click **OK**.
2. Select **File> Print> Print**  to open the **Print** dialog.
 - Click the **Check Plot at** radio button, then choose the desired scale fraction from the drop-down list.
 3. When you are finished printing the check plot, return to the **Page Setup** dialog and change the **Printer Paper Size** back to the setting you will use for a full size printing.

Printing Across Multiple Pages

When printing directly from a floor plan view, cross section/elevation view, or layout it is possible to print at a scale that does not fit the drawing on one page.

When printing to a paper size that is smaller than the sheet size, a 2% overlap is used. Crop marks print where the paper needs to be cut between pages. A solid line is drawn at

the drawing sheet boundary on the sides that need to be cut.

To see on-screen what the drawing will look like when printed, select **Tools> Display Settings> Show Sheet**  and then **Window> Fill Window** . Grey lines across the drawing sheet indicate where the page breaks will occur. See "Show Sheet" on page 845.

Printing to a PDF File

Portable Document Format, or **.pdf** files, are one of the most universally compatible and efficient file formats and can be viewed and printed on most computer platforms.

Creating a **.pdf** document requires that a **.pdf** printer driver be installed on your computer.

This is not a physical print device, but a software program that is recognized as a printer by all other programs and creates a **.pdf** file that can be read and printed using Adobe® Reader®.

When you print to a **.pdf** print driver, you will be asked for a file name and destination automatically.

To print to .pdf

1. Select your **.pdf** printer driver as you would select any other printer in the **Page Setup** dialog. See “Page Setup Dialog” on page 853.
2. Select **File > Print > Print**  to open the **Print** dialog. Your **.pdf** printer driver will be listed as the selected printer.
3. Select the needed options in the **Print** dialog, then click **OK**.
4. In the **Save As** dialog, select a **File name** and **Save in** location for your **.pdf** file. For information about the settings in the **Save As** dialog, see “Saving, Exporting, and Backing Up Files” on page 43.

Line Weights

The weight of a line refers to its thickness on the printed page and is described in absolute terms as a fraction of a unit, often 1/100th of a millimeter or 1/1000 of an inch.

In Home Designer Pro, line weights are assigned to objects, patterns or layers using whole numbers that correspond to the numerator of this fraction.

You can specify the Line Weight Scale by defining the denominator and the unit used in this fraction in the **Page Setup** dialog. See “Page Setup Dialog” on page 853.

The method for changing the line weight for a particular object depends on the object and the type of view.

- Most objects’ line weights can be set in their specification dialogs. See “Line Style Tab” on page 781.
- The line weight for a group of objects can be set by layer. See “Layer Display Options Dialog” on page 104.
- The line weights for walls in floor plan view are defined by wall type in the **Wall**

Type Definitions dialog. See “Wall Type Definitions Dialog” on page 211.

- The line weights of material pattern lines, which are visible in Vector views, can be set in the **Define Material** dialog. See “Define Material Dialog” on page 644.
- The line weight for fill patterns is set for individual objects on the Fill Style tab of their specification dialogs. See “Fill Style Tab” on page 792.
- The line weight applied to surface edges in Vector views can be set in the **Print** dialog. See “Print Dialog” on page 855.
- The end cap length of dashed lines in floor plan view is controlled in the **Preferences** dialog. See “Line Properties Panel” on page 75.
- An assigned line weight of 0 draws a line weight of 1 pixel, the thinnest line weight a printer allows. How thick this is varies from printer to printer. See “Printers and Plotters” on page 843.

Line Weights and Scaling

When a view is sent to layout, line weights may be affected by the drawing scale selected for the view. This occurs when the layout view's scale is different from the drawing scale of the original view.

For example, assume that you have an object in a view with a line weight of 20, and that the view's drawing scale is 1 mm = 50 mm.

- If you send the view to layout at 1 mm = 25 mm scale, twice the original scale, the resulting printed line weight for this object will increase to 40 instead of 20.
- If you send the view to layout at 1 mm = 100 mm scale, half the original scale, the resulting printed line weight for this object will decrease to 10 instead of 20.

You can specify the drawing scale for any orthogonal view by opening the **Page Setup** dialog while in that view. See "Page Setup Dialog" on page 853.

For any layout view, you can specify whether the original line weight is maintained or not in the **Send to Layout** dialog. See "Send To Layout Dialog" on page 867.

Note: Under most circumstances, you should select Use Layout Line Scaling when sending views to layout.

Line weight scaling affects both line weights and line styles and can be particularly noticeable with dashed line styles.

In the following image, the same floor plan view has been sent to layout twice, at two different scales. The view on the left was sent at the same scale as the original view, 1/8" = 1'. The view on the right was sent at

1" = 1', or magnified eight times, to show an area of the plan in greater detail.

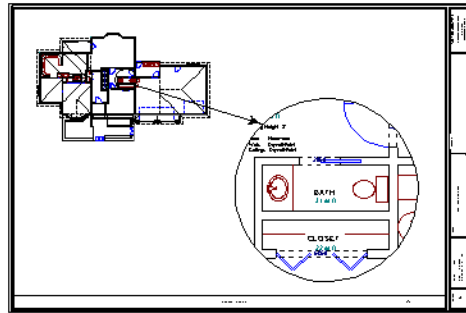

Because the view on the right was sent to layout at a scale other than that of the original, it is subject to layout line scaling.

The solid lines representing walls, cabinets and doors are rescaled to be eight times thicker than in the original view.

Similarly, the dashed lines representing the door jambs are rescaled so that the dashes and the spaces between them are eight times larger than in the original view.

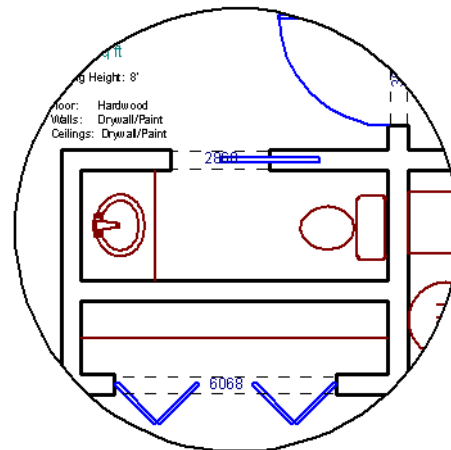

with Use Layout Line Scaling disabled

If **Use Layout Line Scaling** is enabled, line weights are no longer scaled and the dashed lines display at the same size as in the original view.

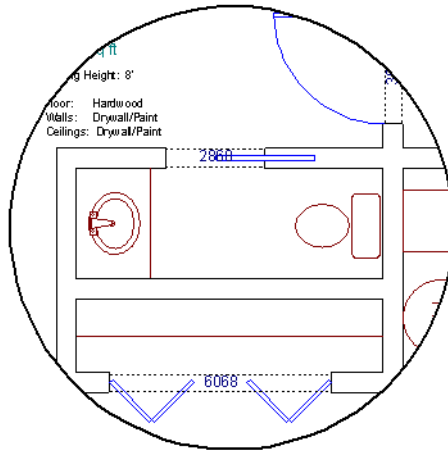

with Use Layout Line Scaling enabled

Because the view in this example is scaled eight times larger in this case, the dashes and line weights look relatively small and fine when **Use Layout Line Scaling** is enabled. Were the view rescaled to be smaller instead, the line weights would look relatively large and thick.

Printers and Line Weight

Line weight and print scaling are subject to the limitations of the printer being used. For

example, you will not be able to see the difference between a line that is 1/150th of an inch wide and one that is 1/300th of an inch wide when they are printed using a printer that prints 150 dots per inch (DPI).

That is, a CAD line with a line weight of 1 will look the same as a CAD line with a line weight of 4 when the Line Weight Scale is set at 1 = 1/600th of an inch and you print to a printer capable of 150 DPI.



The default Line Weight Scale of 1 = 1/100 mm makes it easy to meet many professional drawing standards. In most cases, this scale will produce positive results using any printer or plotter and should not be changed.

Legacy Plans

When plans and layouts created in prior versions of Home Designer Pro are opened in Version 2014, they assume the Page Setup settings, including the Line Weight Scale, specified in the **Preferences** dialog. See “Text & Page Setup Panel” on page 66.

When working with legacy files, using a Line Weight Scale of 1 = 1/X, where X is the DPI of your printer, will produce the most faithful translation from the previous version.

Printing Text and Dimensions

As with other objects your drawings, text and dimension numbers are subject to scaling when views are sent to layout or printed. See “Scaling Text” on page 755.

Printed text size is also influenced by the selected font and the method used to specify its size. See “Character Size” on page 745.

Text may not print exactly as it appears on-screen. To get a better idea of how text and

dimension characters will print, you may find it helpful to **Zoom In**  on them.

For best printed results, using true-type or open-type fonts is recommended.

 Text may not appear accurately on screen when the font used by the printer is different than the font used on screen. Consult your printer documentation for more information on font substitution.

Creating Custom Sheet Sizes

Standard drawing sheet sizes can be selected in the **Page Setup** dialog.

To create custom sheet sizes, select **File> Print> Customize Sheet Sizes** or click **Customize** in the **Page Setup** dialog.

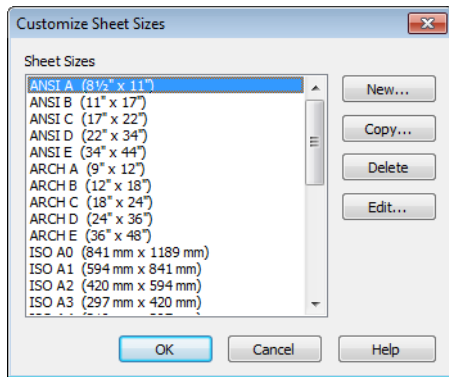

Several options are available:

- Click **New** to create a new sheet size.
- Select a sheet size and click **Copy** to create a duplicate sheet size.

- Click **Delete** to remove the selected sheet size.
- Select a sheet size and click **Edit** to open the **Edit Paper Size** dialog and change its description, dimensions, and units of measurement.

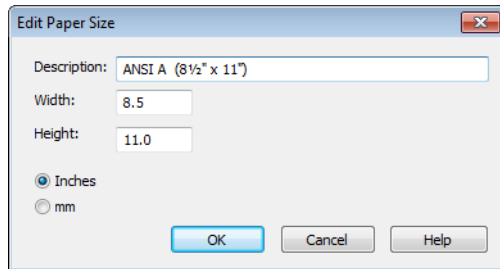

- Click **OK** to close the dialog. Any new sheet sizes created are now available in the **Page Setup** dialog.
- The data for this dialog is stored in the “sheetSizes.sheet” file in the program directory.

Page Setup Dialog

 Select **File > Print > Page Setup** to open the **Page Setup** dialog.

The **Page Setup** dialog is only available when an orthogonal view is active. When a

perspective view is active, **Page Setup**  is not available.

The settings in this dialog, including the selected printer, are specific to the current orthogonal view or layout file, and are saved with the **.plan** or **.layout** file.

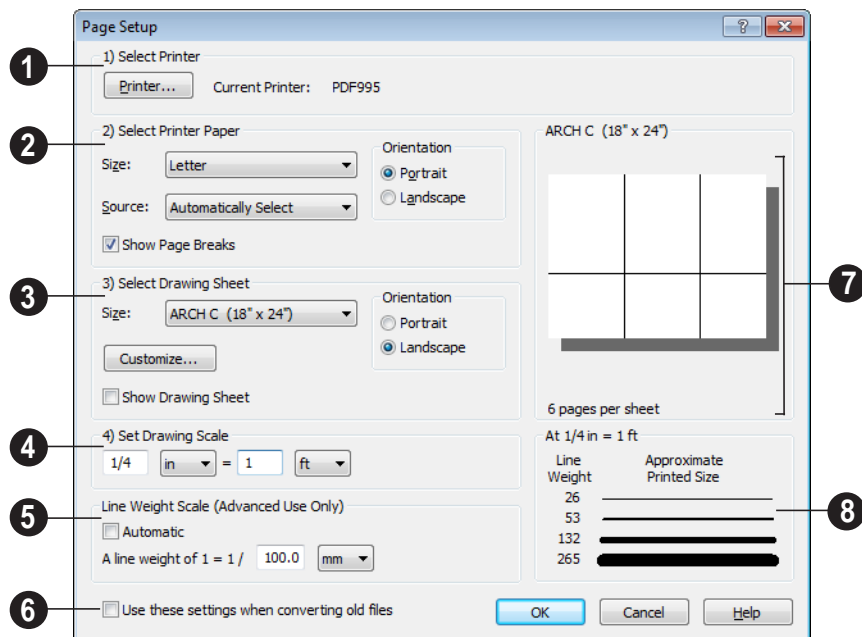

1 Click the **Printer** button to select the current printer or edit its settings. If you have questions about your printer's settings, consult its documentation.

2 Select the printer paper **Size** and **Source**. The options available in these drop-down lists are controlled by the

currently selected printer's driver. See "Printer Drivers" on page 843.

Specify the **Orientation** of the printer paper.

Check **Show Page Breaks** to display page breaks as grey lines across the drawing sheet in the plan or layout view when **Show Sheet** is enabled. See "Show Sheet" on page 845.



Plotters can often have paper inserted into the machine in either of two orientations. Test your own machine and refer to the printer manual to find out which way to insert the paper for correct results.

- 3 Specify the **Size** of the Drawing Sheet, which is the final printed output.

Click the **Customize** button to open the **Customize Sheet Sizes** dialog. See “Creating Custom Sheet Sizes” on page 852.

Specify the **Orientation** of the drawing sheet, which is the orientation of the entire drawing. The dialog preview at right updates as the orientation is changed.

Check **Show Drawing Sheet** to display the drawing sheet on screen.

- 4 Specify the **Drawing Scale** for your printed plan. The scale is specified in two parts, which by default are 1 ft = 1 ft or 1 m = 1 m for layout views, and ¼ inch = 1 ft or 1 m = 50 m for all other views. Both imperial and metric units of measurement are available and can be selected independently.

This scale is applied for printing purposes only and has no effect on the plan scale.

The **Drawing Scale** acts as the default scale for the **Print**, **Printed Size Input**, and **Send to Layout** dialogs.

- 5 Select the **Line Weight Scale**. See “Line Weights and Scaling” on page 850. This setting should always be the same for both a given layout file and any plan views associated with it.

Check **Automatic** to have the program specify the line weight scale and adjust it to maintain line thickness and dash size when the drawing scale is changed. **Automatic Line Weight Scale** is based on a 1/4 inch = 1 foot drawing scale and 1= 1/300 inch line weight scale and is an option for **.plan** files. See “Line Weights” on page 849.

Automatic Line Weight Scale is not available in **Layout** files.



Setting the line weight to zero (0) for any object or group of objects causes the line weight to print as thin as is possible.

- 6 Check **Use These Settings When Converting Old Files** and click OK to establish the current settings as the default settings for plans, and elevations when opening plans created in earlier versions of Home Designer Pro. Layout plans must be set separately. See “Text & Page Setup Panel” on page 66.

- 7 A preview of the drawing sheet and printer paper size displays on the right side of the dialog box.

- 8 A line weight preview shows how changes to the drawing scale affect the printed size of various line weights at the current Drawing Scale.

Clearing Printer Information

Select **File> Print> Clear Printer Info** to clear the printer-specific information stored in the **Page Setup** dialog.

Print Dialog

 To print directly from floor plan view, 3D Vector Views and the Materials List, select **File> Print> Print**. The **Print** dialog opens.

Note: 3D views that are not Vector Views can be printed using Print Image. See “Print Image Dialog” on page 857.

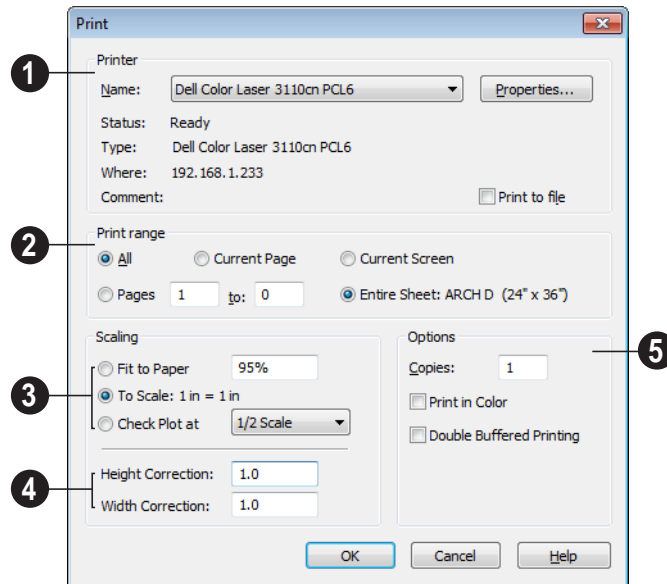

1 Specify the **Printer** parameters.

Browse the **Name** list to choose a printer.

Click **Properties** to verify that the printer is configured correctly. Paper size, orientation, and other settings can be accessed here.

Select the **Print to file** check box if you need to create a file for remote printing.

In the **Print To File** dialog, type the entire pathname of the file to be printed, making sure the name has a **.prn** or **.plt** extension.

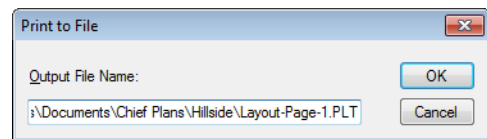

Do not check Print to file if you are creating a **.pdf** file.



Printing to a PDF file is often preferable to printing to file. For more information, see “Printing to a PDF File” on page 848.

- 2** Specify the **Print Range**. This setting is saved between program sessions.
- Select **All** to print the entire drawing. In a plan file, the current view is printed on as many pages as needed. In a layout, all pages are printed.
 - Select **Current Page** to print only the currently active layout page. Current Page is selected by default in layout files.
 - Select **Pages** to specify which layout pages to print, then type the first and last page numbers in the text fields.
 - Select **Current Screen** to print only that portion of the active view that can currently be seen on screen. If you are zoomed out, any blank space beyond the printable objects in the drawing is ignored. Not available in the **Print Materials List** dialog.
 - Select **Entire Sheet** to print the entire sheet even though you may be zoomed in on a portion of the view. Not available in the **Print Materials List** dialog.
- 3** Specify the **Scaling** of the printed output. Not available in the **Print Materials List** dialog.
- **Fit to Paper** prints the view on one page. The program uses whatever scale is necessary to fit the plan on one page.
 - When **Fit to Paper** is selected, specify the percentage of the paper to be used. The default value is 95%; however, any changes to this value are global, affecting all files, and will be retained between sessions.
 - Select **To Scale** to print at the scale specified in the **Page Setup** dialog. See “Page Setup Dialog” on page 853.

- To print a check plot, select **Check Plot at** and choose a scale adjustment from the drop-down list. This temporarily modifies the scale for the current print job but does not alter the scale specified in the **Page Setup** dialog. Line weights are also subject to the temporary scale adjustment. If a drawing sheet larger than the printer paper is specified, a check plot prints across multiple pages.

Note: None of these options override the printer paper size specified in the Page Setup dialog.

- 4** Check the accuracy of your printed scaled documents using **Height/Width Correction**. If your scaled documents are not correct, you can fine tune or calibrate the printer with these adjustments. These numbers are multiplied into the scaling units. Such corrections should only be necessary if you are using a dot matrix printer. Not available in the **Print Materials List** dialog.

 Check printer calibration by printing a four foot square at $\frac{1}{4}'' = 1'-0''$. Measure the print to see if it measures out exactly 1" square.

- 5** **Options** - Only the Copies setting is available in the **Print Materials List** dialog.
- Specify the number of **Copies** you would like to print.
 - Check **Print in Color** to print in color or clear the check box to print in either grayscale or black and white.
 - To print in grayscale, check **Obey Color On/Off Setting** in the **Preferences** dia-

log before printing, then uncheck **Print in Color**. See “Appearance Panel” on page 61.

- To print in black and white, uncheck **Obey Color On/Off Setting** in the **Preferences** dialog before printing, then uncheck **Print in Color**. Lines and fill colors print as either black or white, depending on which is closer to the line or fill’s actual color.

Most black and white printers print a grey scale approximation of the colors if **Print in Color** is selected.



Printing to pen plotters is not supported.

Double Buffered Printing uses computer memory to render the output at printer

resolution. The resulting bitmap is then printed. This can greatly improve print speed when printing Vector Views, but a lot of memory is required. This method is not normally recommended for layouts, plans, or details; however, it may help you avoid issues with certain drivers for older printers. See “Printers and Plotters” on page 843.

If there are a lot of pictures on your plan or layout, using double buffered printing may improve your print speed.

Line Weight - Available for Vector Views only. Specify the Line Weight for all lines defining the edges of 3D objects. This is a global setting for all edges. Individual lines, other than superimposed CAD lines, cannot be defined with different line weights.

Print Image Dialog

 Any view can be printed by selecting **File> Print Image**. This is the only way to print most 3D views. See “3D Rendering” on page 697.

The **Print Image** dialog is similar to the **Print** dialog; however, the printing process is different. **Print Image** prints individual pixels as opposed to vectors (lines).

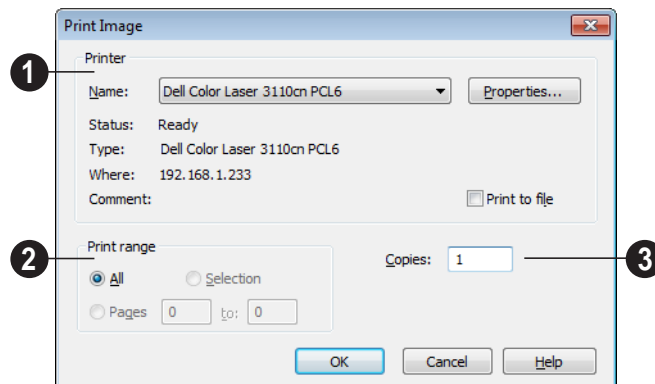

- 1 Specify the **Printer** parameters.
 - Choose a printer from the **Name** drop-down list.
 - Click **Properties** to verify that the printer's paper size, orientation and other settings are configured correctly.
 - Select the **Print to file** check box to save the print to a file for remote printing. For

more information, see "Print Dialog" on page 855.

 Printing to a PDF file is often preferable to printing to file. For more information, see "Printing to a PDF File" on page 848.

- 2 Specify the **Print Range**.
- 3 Specify the number of **Copies**.

Print Model



The Model Maker allows you to create a template of your plan that can be printed to scale and assembled into an actual 3D model. Three groups of templates are used in the process. Walls and roofs are printed separately. These can then be placed onto a floor plan view, which is printed as a layout for the entire model.

Since different people build house models in different ways, the Model Maker focuses on providing the most necessary tools. It may not necessarily give you everything you might want in order to build house models your way. For example, you may want to affix tabs to certain wall or roof edges to help attach them to their neighbors. While you

can draw some of these things onto printed sheets, the system does not provide them automatically. What it does provide is accurate templates for wall and roof sections. Combining these with your own skills helps you create professional quality models.

Printing the Model

The best way to understand how the various options affect the final product is to make a very simple two story plan and try them out.

To print the model templates, choose **File>**

Print> Print Model . The **Print Model** dialog opens.

Print Model Dialog

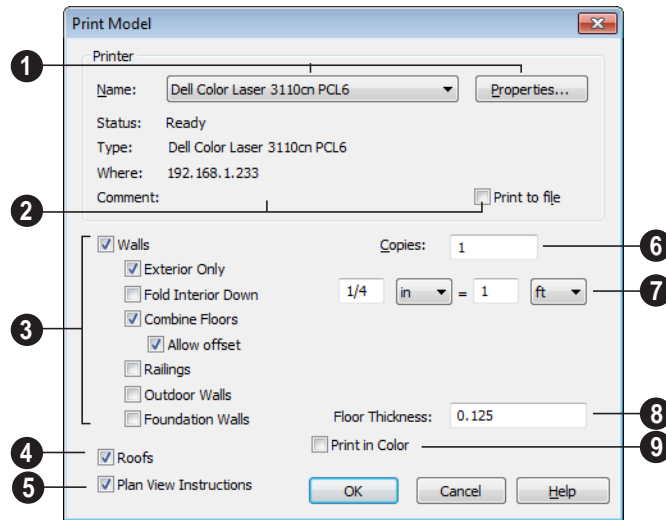

- 1 **Printer** - Select the printer for your model. Larger sheet sizes are better. Landscape is usually the best mode for printing models. If it is not your default printing mode, it can be selected via the **Properties** button.
- 2 **Printer Info** - Information about your printer and its current setup displays here.
 - Check this box if you prefer to **Print to File**. Leave this unchecked if you are printing to .pdf.
- 3 Uncheck **Walls** to prevent walls from printing. When Walls is checked, the settings below are available.
 - Check **Exterior Only** to suppress interior wall surfaces. Normally it is only the exterior walls that display in a model. If interior walls and surfaces are produced, much more paper is required. Interior surfaces are typically printed when com-

posing a model of only the current floor, without a roof.

- Check **Fold Interior Down** to print the interior surface of a wall above its corresponding exterior surface and upside down. This allows both walls to be cut in one piece and folded over. This is convenient when making a separate model for each floor to show its interior.
- Check **Combine Floors** to print together the exterior surfaces of walls that are on top of each other. Interior surfaces of those walls still print separately.
- **Allow Offset** modifies the outcome of the **Combine Floors** option. Normally, the main layers of stacked walls must be closely aligned and have the same thickness for walls to combine. Check this box to allow an offset of up to six inches (15 cm) and allow different thicknesses.

- Check **Railings** to print railings along with walls.
 - Check **Outdoor Walls/Foundation Walls** to include Outdoor Walls and/or Foundation Walls in the walls group. This also affects which walls display in the floor plan view template.
 - **Outdoor Walls** - An Outdoor wall is normally a garden wall or a wall used as a fence. It may be a **No Room Def.** type wall, see “Wall Specification Dialog” on page 214, or have exterior type rooms, such as Deck, Porch, or Attic on both sides of it. If a plan has extensive outdoor walls, printing them all may use a considerable amount of paper.
 - **Foundation Walls** - Walls on floor zero, the foundation floor, still print unless they are specified as foundation walls on either the General or Foundation tab of the **Wall Specification** dialog.
- 4 Uncheck **Roofs** to suppress roofs from printing.
 - 5 Uncheck **Plan View Instructions** to suppress floor plan view instructions from printing.
 - 6 Specify the number of **Copies** to be printed.
 - 7 Specify the **Scale** to be printed in inches per feet. A simple ratio (1:48 for example) is used for metric plans.

The system arranges as many wall or roof sections as possible onto a single sheet. For larger scale models, a printer with a larger sheet sizes is helpful. If any wall surface, roof surface, or floor plan view covers more than one sheet, it prints by itself on the

number of sheets required. Models with large surfaces may require a lot of paper.

- 8 Specify the **Floor Thickness**, which is the thickness of the material you use for the floor platform.
- 9 **Print in Color** - This option depends on whether you have a color printer. Check this box to print in color.

Assembling the Model

Once the templates have been printed, they are ready to be assembled. You need scissors and an adhesive and a rigid material that can be easily cut and glued, such as thin cardboard or styrofoam, to provide support for the 3D model.

Floor Plan View Template

Begin by laying out the floor plan view, which is used as a layout for the entire 3D model. If your floor plan view template printed on a number of sheets, they should be combined into one. Exterior and interior wall surfaces should match throughout.

Adhere your complete floor plan view template to a sturdy and dedicated surface to provide support for your walls.

Walls

Walls should be cut and fixed to a rigid backing so that they can stand on their own and support the weight of the roof or floors above them. How they are cut and assembled varies depending on the desired final appearance of the model and how they were printed.

It may be helpful to take the thickness of the rigid material being used into consideration

and override the scale thickness of the walls so that it agrees with your material thickness.

If your walls were resized in the **Print Model** dialog, you may see unwanted lines between floors that should merge together seamlessly. This is usually due to walls whose exterior surfaces match but overall thickness does not. You can prevent this by checking **Use Scale Wall Thickness**, which prevents walls from resizing. This is best if you do not want to print the interior wall surfaces, or are

using a modeling material that closely matches the scale thickness of your walls.

Roofs

Roof planes are joined together when possible before printing. For each roof surface, the fascia and soffit surfaces are attached at the eave, so that the least amount of taping produces the roof and adjoining surfaces.

Layout

The Home Designer Pro layout facility offers a set of easy to use tools for arranging multiple views on a single page for printing.

Each layout page can contain multiple views, details, images, CAD objects or text.

For detailed information about printing in Home Designer Pro, see “Printing & Plotting” on page 841.

Chapter Contents

- Layout Defaults
- Preparing for Layout
- Creating a Layout File
- The Layout Tools
- Sending Views to Layout
- CAD and Text in Layout
- Pictures and Metafiles in Layout
- Keeping Layout Views Current
- Displaying Layout Views
- Layout Page Display Options
- Opening Layout Views
- Managing Layout Links
- Printing Layout Files
- Exporting Layout Files
- Layout Box Specification Dialog

Layout Defaults



To access the layout defaults for the current layout file, select **Edit>**

Default Settings. The options in the **Default Settings** dialog are similar to those found in this same dialog in a plan file, although there

are fewer choices in the list. See “Default Settings” on page 56.

In the **Default Settings** dialog, select **Layout** and click **Edit**.

The settings in the **CAD Defaults** dialog in layout are similar to those in a plan file but only affect CAD drawn on the layout page. Some options that do not apply to layouts are disabled. See “CAD Defaults Dialog” on page 770.

The settings in the **Layout Defaults** dialog are similar to those in the **Plan Defaults**

dialog. Some options that do not apply to layouts are disabled. See “General Plan Defaults Dialog” on page 58.

The settings in the **Page Setup** dialog are also file-specific and are particularly important considerations in layout files. See “Page Setup Dialog” on page 853.

Preparing for Layout

Very little preparation is necessary before creating a layout file. There are a few things that are helpful to keep in mind.

Printer Setup

You can print to any printer or plotter that uses a Windows driver and can change the current printer at any time in the **Page Setup** dialog. See “Page Setup Dialog” on page 853.

Printing Services

Find out what paper size the print service uses and select it in the **Page Setup** dialog.

If you plan to use a printing service, you will need to install a PDF writer. See “Printing to a PDF File” on page 848.

You can also print to file using the driver for the printer that the service will use. See “Printer Drivers” on page 843.

Check Plots

When a large drawing sheet size has been specified, you can print a check plot at a reduced scale so that it can be printed on a smaller printer. This allows you to make final checks before printing to the larger size. See “Check Plots” on page 847.

Creating a Layout File



Choose **File> New Layout** to create a blank layout file. A layout file is created with the name **untitled.layout**.

If a layout file is not open when you try to send a view to layout, a warning message will ask you if you want to create a new layout file. See “Sending Views to Layout” on page 866.

To open an existing layout file, select **File> Open Layout** . Browse to a directory and select the layout file to open. See “Opening and Importing Files” on page 48.

Only one layout can be open at a time. When a layout file is open, it is listed at the bottom of the Window menu as an open view.

Select **File> Save**  to save the layout file. It is important that you save the layout in the same directory as the plan file from which

views have been sent to the layout page. See “File Management” on page 39.

Although it is possible to use multiple plan files with a layout, it is generally best to associate only one plan file with a layout and to use the same file name for both. If more than one plan file is used, all should be saved in the same directory as the layout file.

When you save your layout, take a moment to also save the plan file associated with it.



When a view is sent to layout, the layout view is linked to the **.plan** file. Do not change the path name by moving the **.plan** file to a new folder or renaming it. If the path name is changed, the link in the layout file must be reestablished for the view to appear in layout. See “Managing Layout Links” on page 873.

The Layout Tools



There are a variety of tools available to send views to layout and edit them, as well as manage links.

Many of the tools available in layout are described in the Printing chapter. See “The Printing Tools” on page 844.

Sending Views to Layout



Select **File> Send to Layout** to open the **Send to Layout** dialog and send the current view to the specified layout page. See “Sending Views to Layout” on page 866.



In floor plan view, select a saved cross section/elevation view symbol and click the **Send Camera’s View to Layout** edit button. See “Saving & Printing 3D Views” on page 690.



Select a layout view and click the **Open View** edit button to open the view that was originally sent to layout. This tool is only available for dynamic views. See “Editing Dynamic Views” on page 871.



Select **Window> Swap Views** to switch between the current view and

the view that was current before it. See “Swapping Views” on page 656.



Click the **Show Layout** button to switch to a layout file that is currently open.

Sending Views to Layout



Layout files can contain multiple views sent to it from one or more plan files. To send a view from a plan file to layout, select **File> Send to Layout**.

You can also send one or more saved, closed cross section/elevation views to layout by selecting the camera symbol and clicking the

Send Camera’s View to Layout  edit button. See “Saving & Printing 3D Views” on page 690.

When a view is sent to layout, the program sends it to the layout file that is currently open. While more than one plan file can be open at once, only one layout file can be open at a time.

If no layout file is open, the program searches for a layout file with the same file name as the plan that the view is being sent from. If it cannot find such a layout file, the program asks if you want to create a new layout and send the view to it.

To send a view to layout

1. Prepare the view so that objects that should be seen are visible and those that should not be suppressed. See “Layer Display Options Dialog” on page 104.

Remember that if the Reference Display is turned on when a view is sent to layout, it becomes a static part of the view and cannot be turned off later. See “Reference Display” on page 327.

2. Select **File> Send to Layout** . In the **Send to Layout** dialog, the available options vary depending on the type of view being sent to layout.
3. Click **OK** to send the view to the specified layout page. Depending on the type of view and size of the model, you may see a progress indicator in the Status Bar. See “The Status Bar” on page 31.

Send To Layout Dialog

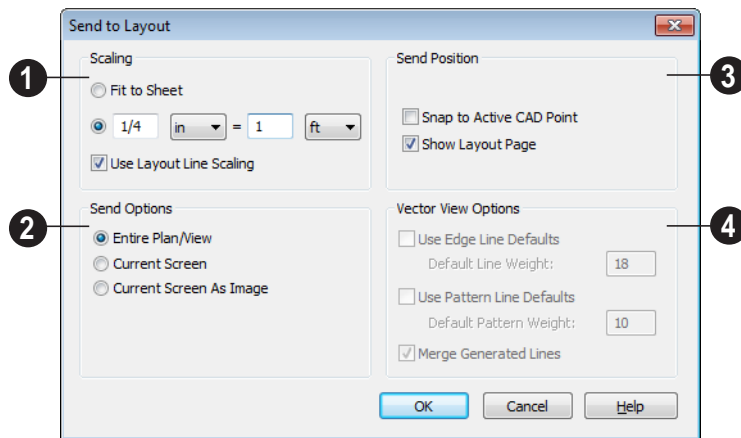

- 1 Select a radio button to specify the method of **Scaling** for the view sent to layout.
 - Select **Fit to Sheet** to send the view to layout at no specific scale. The view can be resized on the layout sheet later.
 - Specify the **exact scale** for the view in layout. Both Imperial and metric units of measurement are available and can be selected independently.
 - When views are sent to layout at different scales, line weights and line styles are subject to the same scaling. See “Line Weights and Scaling” on page 850. In most cases this is not desirable. When **Use Layout Line Scaling** is checked, the lines in views sent to layout appear the same as lines drawn directly on layout. This option is not available for rendered views.
- 2 Which **Send Options** are available depends on the type of view being sent to layout.
 - Select **Entire Plan/View** to send to layout the extent of the plan that is visible when you click **Fill Window** . This option is available for Vector views, wall details, and cross section/elevation views.
 - Select **Current Screen** to send only what is shown on screen to layout. This option is available for Vector Views.
 - Select **Current Screen As Image** to send only what is shown on screen to layout as an embedded image. See “Picture File Box Specification Dialog” on page 813. This option is available for all views, and is the only option available for rendered views.
- 3 Specify the desired **Send Position** for the view. These options are available for all views.
 - Check **Snap to Active CAD Point** to snap the view you are sending to layout to the active CAD Point. See “Point Tools” on page 772.

- Check **Show Layout Page** to go to the selected layout page when you click OK.

4 The **Vector View Options** are only available when a 3D view using the Vector View Rendering Technique is sent to layout. See “Rendered and Vector Views” on page 665. These settings are preserved between sessions.

- Check **Use Edge Line Defaults** and specify a **Default Line Weight** to override all layer specific and object specific line weight settings when the view is sent to layout. If unchecked, the layout view respects the **Surface Edge Lines** settings in the **3D View Defaults** dialog. See “3D View Defaults Dialog” on page 668.
- Check **Use Pattern Line Defaults** and specify a **Default Pattern Weight** to

override the Line Weight setting in the **Define Material** dialog. See “General Tab” on page 645.

- Uncheck **Merge Generated Lines** to prevent the merging of colinear lines. Horizontal and vertical lines still merge.

If **Merge Generated Lines** is selected and a cross section/elevation view is sent to layout, the program merges any lines that are superimposed or parallel with each other so that the layout has only one line rather than several. This makes the final view easier to edit in layout if necessary, but may slow down the process of sending 3D views containing non-vertical or horizontal lines to layout.

CAD and Text in Layout



CAD objects and text can be incorporated into your layout by both including them in your views sent to layout and by drawing them on the layout page.

In Views Sent to Layout

CAD and text in views sent to layout are scaled just like other objects in the view. If you want text in a layout view to print at a particular size, specify its size based on the scaling you will use when you send the view to layout. See “Character Size” on page 745.

If you rotate a view on the layout page, any text in that view will rotate as well, provided

that its Text Style is using the **Rotate with Plan** setting. See “Text Styles” on page 765.

On the Layout Page

CAD and Text objects can also be added directly to any layout page. These are added to the layout page itself, not to any specific view on the page which may have its own CAD and text objects within it.

CAD and Text objects created in layout can be selected and edited just as they can in other views. See “Editing Text” on page 754 and “CAD Objects” on page 769.

Pictures and Metafiles in Layout

Picture files and metafiles can be imported onto a layout page just as they can into floor plan view. See “Displaying Pictures and Metafiles” on page 817.

Views can also be sent to layout as pictures. In fact, Rendered views sent to layout are always treated as imported pictures embedded in the file. See “Send To Layout Dialog” on page 867.

A picture or metafiles imported onto the layout page can be selected and edited using its edit handles, edit tools and specification dialog. See “Editing Pictures and Metafiles” on page 817.



Embedded pictures increase layout file size. Limit the number of large and/or multiple pictures.

Keeping Layout Views Current

If a plan changes after views of the model are sent to layout, some of the views may become out of date. Depending on the type of view, some may update automatically and other must be updated manually.

Dynamic and Static Views

A dynamic view references the view saved with the original plan. Any changes made to the original plan update the dynamic layout view.

For information about controlling the display of dynamic views in layout, see “Displaying Layout Views” on page 872.

A static view does not reference the original plan and does not update when the plan changes. Static views are like a snapshot taken at a specific time; subsequent changes do not appear in that snapshot. Changes made in the original plan must be resent to layout manually.

Floor Plan Views



Floor plan views sent to layout are dynamic. Any changes made to these items in plan are reflected automatically in layout.

- The display of everything is under your control. All editing must be done in floor plan view, and all changes are automatically reflected in layout.
- To edit the layer settings of a floor plan view sent to layout, select the view and click the **Open View**  edit button. This opens the plan file where editing can be done. Any changes made update the layout.
- If the reference display is on when a floor plan view is sent to layout, it becomes a permanent part of that layout view. See “Reference Display” on page 327.

Bear in mind that when you open a view to edit it, any changes that you make to your layer settings will be reflected on the layout page. When you are finished making changes to your layout view and wish to resume work

on the plan, save your work, close the plan, and then open it again. This will help avoid unintended changes to your layout view.

Cross Sections/Elevations

Views created using the **Cross Section/Elevation** , **Wall Elevation** , and

Backclipped Cross Section  tools are dynamic, but their behavior in layout is different from other dynamic views.

- CAD objects, text, and dimensions can be added to cross section/elevation views. If the view has been sent to layout, they are automatically shown in the layout view provided that their layer was set to display in the view's layer set when the view was sent to layout.
- CAD objects added in a cross section/elevation view can only be edited in the cross section/elevation view.
- Double-clicking a cross section/elevation view in layout using the **Select Objects**  tool activates the original view, allowing you to modify the model or add CAD objects.



Updating Cross Sections/Elevations

If a cross section/elevation view is sent to layout, and that camera view is later closed while the layout sheet is open, you will be asked to choose whether to update the view on the layout page.

- If the layout view is up-to-date with the 3D model or if you do not want your changes to be seen in the layout view, select **No**.
- To update the view on the layout page choose **OK**. Any changes that you might have made to the layout view will be lost.

Static Views

With the exception of **Cross Section/**

Elevation , **Backclipped Cross Section** , and **Wall Elevation**  views, all camera views and overviews sent to layout are static. They are treated as imported images embedded in the layout file. See “Picture File Box Specification Dialog” on page 813.

Any changes made to the 3D model have no effect on static views. To update these views in layout, delete the old view and send a new one. See “Dynamic and Static Views” on page 869.

Editing Layout Views

To edit a layout view, first select its layout box using the **Select Objects**  tool. Once selected, the view box can be edited using its

edit handles, edit toolbar or specification dialog. See “Layout Box Specification Dialog” on page 875.

Using the Edit Handles

Layout view boxes can be edited like CAD boxes. See “Editing Box-Based Objects” on page 141.

Floor plan views can be rotated. Both the layout box and the view inside it rotate. Cross section/elevation and 3D views sent to layout cannot be rotated.

In the Specification Dialog

Layout views can be customized in their specification dialog. See “Layout Box Specification Dialog” on page 875.

Using the Edit Tools

A selected layout view or views can be edited in a variety of ways using the buttons on the edit toolbar. See “The Edit Toolbar” on page 29.

Moving Layout Views

Layout views can be moved using the Move edit handle using dimensions. See “Moving Objects Using Dimensions” on page 737.

Copying Views

Just like many objects, views sent to layout can be copied and pasted into different layout files.

As a general rule, though, if multiple copies of a view are needed, it is best to send the view to layout as many times as necessary because each view can then be controlled independently.

Bear in mind, too, that if a layout has views copied from a different layout file and is later moved to a different location on your computer, the link to the original plan file may be broken. See “Keeping Layout Views Current” on page 869.

Editing Dynamic Views

Select a dynamic view and click the **Open View**  edit button to open the original view that was sent to layout. You can also double-click a dynamic view in layout to open the original view. See “Dynamic and Static Views” on page 869.

Resizing Scaled Views

Scaled views retain their scale regardless of how you resize the border. You can resize the border proportionally from a corner handle or select one of the handles on an edge to change the size in one direction only. The image may be cropped if the border is resized small enough.

Resizing Non-Scaled Views

If the view was sent to layout using the **Fit to Sheet** setting, resizing may have one of several results:

- Drag a corner handle in or out to resize both the border and the image proportionally.
- If you drag a side handle in or out, the image stays the same size, but the border changes. If you make the border smaller, it may crop the image; if you make it larger, you may show more of the image.

Displaying Layout Views

When a view is sent to layout, the current layer display settings are used. See “Displaying Objects” on page 102.

Once sent to layout, static views cannot be changed. See “Dynamic and Static Views” on page 869.

The layer display settings referenced by a dynamic view are saved with the plan rather than the layout file, and the display of the view can be modified by turning layers on or off in the original view.

Layout Box Borders and Labels

A border will display around each layout box when the “Layout Box Borders” layer is set

to display in the **Layout Page Display Options** dialog. See “Layout Page Display Options” on page 872.

Layout boxes can also display labels when the “Layout Box Labels” layer is set to display. See “Object Labels” on page 884.

Automatic layout box labels display basic information about the original view in the plan. For example, floor plan view sent to layout from Floor 1 will have an automatic label that says, “1st Floor”. A camera view sent to layout will have a label that states the camera’s name. Layout box labels can be customized in the **Layout Box Specification** dialog. See “Label Tab” on page 877.

Layout Page Display Options



Select **Tools > Display Settings > Display Options** from a layout file to open the **Layout Page Display Options** dialog.

The **Layout Page Display Options** dialog is similar to the **Layers Display Options** dialog, but controls only the display of objects drawn on the layout page, such as the

layout borders and other CAD objects, text and dimensions.

For information about how to use this dialog, see “Layer Display Options Dialog” on page 104.

For information about controlling the display of views sent to layout, see “Displaying Layout Views” on page 872.

Opening Layout Views



Dynamic views sent to layout reference an original view in a plan. From the layout page, you can quickly access that original view by selecting a layout view, then clicking the **Open View** edit button. The original view can also be opened by double-

clicking the layout view using the **Select Objects**  tool.

Changes made in this view update in the original layout view. Depending on the changes, other views may also be affected.

Managing Layout Links

Home Designer Pro allows you to review plan files linked to a current layout, change existing links from one plan file to another, and reestablish links to plan files that have been moved or renamed.

Protecting Layout Links

Careful file management is needed to avoid missing files and disrupted layout links. See “File Management” on page 39.

The following guidelines can help prevent layout links from being broken:

- Save plan files in the same folder as the layout, or in a sub-folder in that folder.
- Legacy plan files referenced by a layout must have the **.plan** file extension. Plans from version 6.0 with the **.pl** file extension cannot link to **.layout** files.
- Custom graphics included in a plan or layout should be embedded in the file or saved in the same folder as the layout.
- Plan files should never be renamed. If a new name is desired, make a copy of the file and rename it. Changes made in the copy do not affect the layout.
- Avoid sending cross section/elevations to layout more than once. Changes made to the view can affect layout views in unintended ways.
- Layout files should never be moved. If a layout file must be moved, the entire

folder it is saved in should be moved or copied and then moved.

- Use **File > Backup Entire Plan**  to create an independent copy of the original layout. Avoid use of “Save As.” See “Backup Entire Plan” on page 52.

Finding Missing Files

When a layout file is opened, the program performs a breadth-first search for dynamically linked views. This means that it:

- Looks first in the same folder as the layout.
- Looks next in the folders located closest to the layout’s folder.
- If a missing file is not found, it expands its search further from the location of the layout file until the files with the linked views are located.
- If a missing file is not found, a second breadth-first search will be performed, searching all zipped files found in the first search.

If a file remains missing after the program performs a search of your system, a Warning message will indicate that the program could not successfully open all of the layout’s associated plan files. When you click OK, the **Layout Files** dialog will open, allowing you to relink the layout to its missing associated files.

Layout Files Dialog

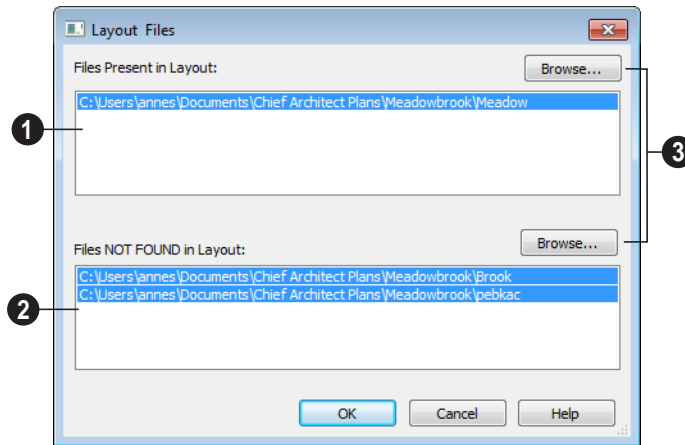

- 1 **Files Present in Layout** lists all files with intact links to the layout.
- 2 **Files NOT FOUND in Layout** lists the names of files with disrupted links to the layout. Any files listed here have been moved, renamed, or deleted and cannot be found by the program. Intervention is required to find these files and reestablish their links to the layout.
- 3 Select a missing file and click the **Browse** button just above the NOT FOUND field to open the **Browse For Missing File** dialog, which is a typical **Open** dialog. See “Opening and Importing Files” on page 48.
 - Locate the missing file in your system’s directory structure. When the missing file is selected, click **Open** to link it to the layout.
 - You can also redirect an intact link to from a File Present in Layout to a different file in the same manner.

Be sure to choose **File> Save**  when the missing files have been located to save their links to the layout file.

Results of Missing Files

If all missing files are correctly redefined, the layout opens when you click **OK**.

If an error message displays, one or more of the missing files could not be replaced by the redefined file. Click **OK** to continue. The layout opens, but with the following characteristics:

1. Any floor plan views associated with the missing file(s) are blank. Only the border displays.
2. Any elevations or cross sections associated with the missing file(s) show the automatically generated lines, but any added CAD objects are absent.

Printing Layout Files



Printing layout files is similar to printing directly from a view in a plan file. See “Printing Directly from a View” on page 846.

As in a plan view, printing options for layouts are set in the **Page Setup** dialog. These options apply to the layout file. See “Page Setup Dialog” on page 853.

Select **File> Print> Print**  to open the **Print** dialog. See “Print Dialog” on page 855.

Scaling

The drawing scale is specified in the **Page Setup** dialog. While you can specify any drawing scale that you wish, in nearly all circumstances, you will want the scale to be **1 in = 1 in** for all layout files.

The views sent to your layout page has already been assigned a scale, and if you select a scale other than **1 in = 1 in** in the **Page Setup** dialog, these views will be scaled a second time when printed.



Layout views will print at their specified scales only when the drawing scale for the layout file is 1 in = 1 in.

You can also print a Check Plot which is a test printing, typically at a smaller scale, made before final output to large paper format. See “Check Plots” on page 864.

When a view is sent to layout at a scale other than that used by the original view, line weights may be affected. See “Line Weights and Scaling” on page 850.

Exporting Layout Files



A layout can be exported to a **.dxf** file much like any other vector-based view.

The main difference is in the scale of the output, which is in scaled paper units rather

than model units. If a 50” line in a plan would be scaled to 1” inch when printed, it is exported as a 1” line instead of its length before prior to scaling. See “Exporting 2D DXF Files” on page 833.

Layout Box Specification Dialog



A layout box is essentially a CAD box that contains a view that has been sent to layout from a plan. When selected, a layout box has edit handles similar to those of a CAD box that allow you to rotate, relocate, and resize the layout box. See “Editing Box-Based Objects” on page 141.

Select a layout view and click the **Open Object**  edit button to open the **Layout Box Specification** dialog, which is very similar to the **CAD Box Specification** dialog.

General Tab

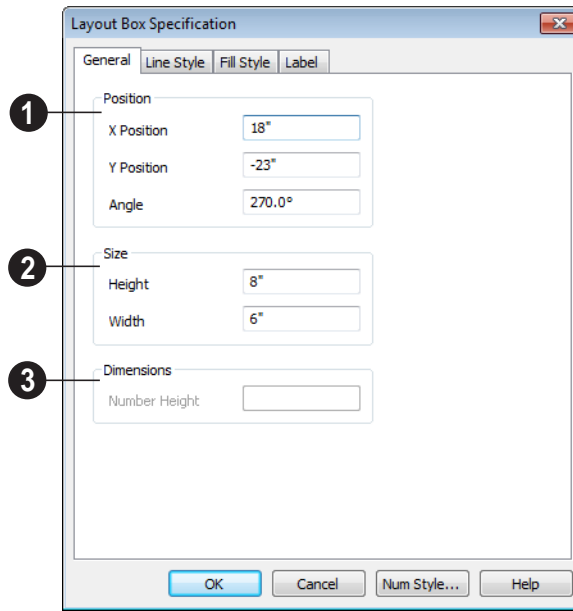

- 1 Specify the **Position** of the selected view's bounding box. See "3D Drafting" on page 25.
- 2 Specify the **Size** of the selected view's bounding box.
- 3 Specify the **Number Height** for **Dimensions** in the selected view. Type a (D) to use the default height for the selected view. See "Dynamic Defaults" on page 57.

This setting is only available for views sent to layout from floor plan view and CAD Details. It affects the size of dimension numbers in the layout view but not in the original view in the plan file.

 The Number Height setting is included for legacy files and is not the recommended method of specifying dimension size. See "Dimension Labels" on page 732.

Line Style Tab

The Line Style tab allows you to set the properties of the selected layout box and to specify the selected layout box's layout page.

For more information, see "Line Style Tab" on page 781.

Fill Style Tab

For information about the Fill Style tab, see "Fill Style Tab" on page 792.

Label Tab

Layout box labels display in floor plan view when the “Layout Box Labels” layer is turned on and use the Text Style assigned to

that layer. See “Layout Box Borders and Labels” on page 872.

For more information about the settings on this tab, see “Label Tab” on page 885.

Plant Schedules & Object Labels

A Plant Schedule is a table that lists all of the plants in your plan and can include a variety of information about them, including quantities, common and scientific names, and growing needs.

Schedules update automatically whenever a plant is created, deleted, moved, or altered.

You should check each schedule carefully to be sure it accurately represents what is in the model. Never assume it includes what you expect or need.

A variety of objects in Home Designer Pro have labels that display information about them in floor plan view. In addition, plants can display callout labels with schedule numbers instead of their default labels.

Chapter Contents

- Creating and Editing Schedules
- Schedule Specification Dialog
- Columns to Include
- Object Labels

Creating and Editing Schedules

In floor plan view, select **Terrain > Plant > Plant Schedule**, then click anywhere in the view to place a schedule at that location. You can continue clicking to place additional copies of the schedule. See “Click-to-Create” on page 113.

Schedules can be edited using the edit handles, the edit toolbar buttons, or the **Schedule Specification** dialog.

Edit Handles

A selected schedule has the same edit handles as a CAD box. See “Editing Box-Based Objects” on page 141.

In addition, schedules have edit handles along the side of each column, in the Schedule heading near the top. Click and drag one of these handles to adjust the width of the columns on either side.



The behavior of the edit handles may depend on the currently active Edit Behavior. See “Edit Behaviors” on page 120.

In the Specification Dialog



The appearance and other attributes of schedules can be modified in the **Schedule Specification** dialog.

You can control how objects are listed by specifying which Columns to Include. For example, if you were to uncheck “Common Names” and “Scientific Names” in the **Plant Schedule Specification** dialog, and then check “Flower Color”, the resulting schedule would list all red flowers in one line item, regardless of their species.

Using the Edit Tools

A selected schedule or schedules can be edited in a variety of ways using the buttons

on the edit toolbar. See “The Edit Toolbar” on page 29.

Schedule Numbering

Schedule numbering is dependent on the order in which objects are placed in the plan, as well as the floor they are on.

- Any objects present in your plan before a schedule is created will be listed first in ascending alphanumeric order, according to their Label information.
- A new, unique objects placed in the plan after the schedule is created will be added to the bottom of the schedule in the order that they are placed, regardless of its Label information.

When an object is edited, its schedule number may or may not change:

- If an object with a Quantity of 1 in the schedule is edited, its position in the schedule will not change.
- If a group of objects listed on the same row in a schedule are edited simultaneously, their position will not change.
- If an object listed on the same row in a schedule with other similar objects is edited so that it is no longer similar enough to share the same row, it will move to the bottom of the schedule. See “Columns and Quantity” on page 884.

Schedule Specification Dialog



Schedules can be edited in the **Schedule Specification** dialog. To open this dialog, either select a schedule and

click the **Open Object** edit button or double-click the schedule using the **Select Objects** tool.

Schedule Tab

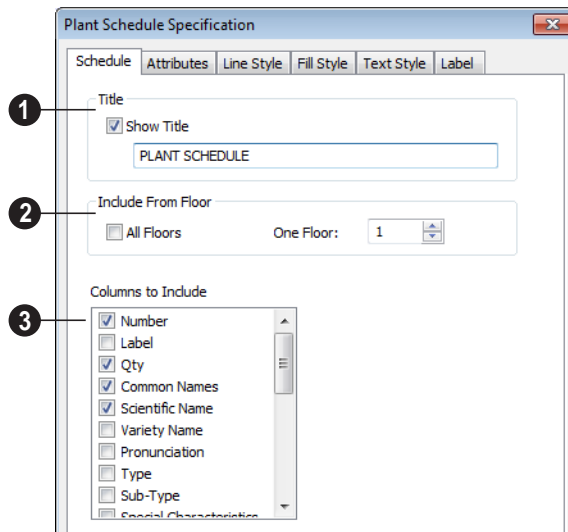

- 1 Specify a **Title** for the selected schedule. Check **Show Title** to display the title at the top of the schedule.
- 2 **Include From Floor** - Specify the floor whose objects appear in the schedule. The default for all schedules except for room and plant schedules is **All Floors**.
 - Uncheck **All Floors** to specify a particular floor in the text field.
- 3 **Columns to Include** - Check the box for each column you want to display in the schedule. At least one column must be checked to create a schedule.

Columns may be added or removed at any time by selecting or clearing check boxes. See “Columns to Include” on page 884.

Attributes Tab

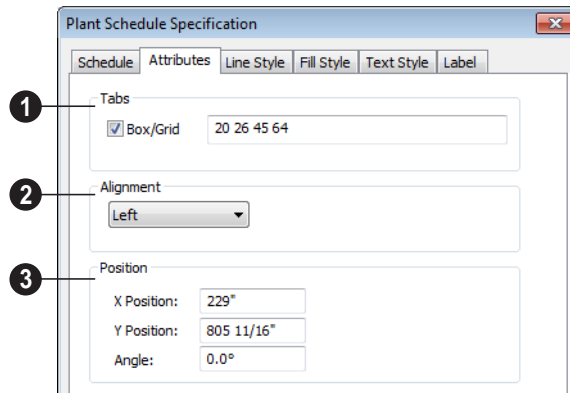

- 1 Specify the appearance of the selected schedule's **Tabs**.
 - Check **Box/Grid** to display lines around the rows and columns of schedule, forming boxes around each item.
 - In the text field, specify the number of spaces from the left edge of the schedule where each new column begins. The first column always starts at 0. In this case, the second column starts 22 spaces in, the third, 31 spaces in, and so on.
- 2 Specify the **Alignment** of the selected schedule's text within its columns by choosing an option from the drop-down list.
- 3 Define the **Position** of the selected schedule.
 - Specify the **X and Y Positions** of the schedule's center point.

- Specify the schedule's **Angle**.

Line Style Tab

The Line Style tab is found in the specification dialogs for many different objects. For more information, see "Line Style Tab" on page 781.

Fill Style Tab

For information about the settings on this tab, see "Fill Style Tab" on page 792.

Text Style Tab

The settings on this tab control the appearance of the selected schedule's text. For more information, see "Text Style Tab" on page 766.

Label Tab

The Label tab of the **Plant Schedule Specification** dialog controls the type, size

and appearance of the labels that display in floor plan view.

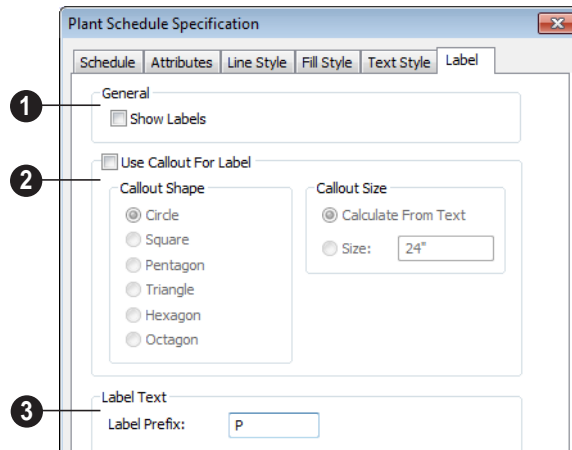

- 1 Check **Show Labels** to display object labels in floor plan view. This also turns on the appropriate layer for the objects labels in the **Layer Display Options** dialog. See “Layer Display Options Dialog” on page 104.

You can suppress the label for an individual door or window by checking **Suppress Label** in the specification dialog for that object. See “Label Tab” on page 885.

- 2 When **Use Callout For Label** is checked, the callout shape and size can be specified below. When this option is unchecked, Automatic or user specified labels are used. See “Label Tab” on page 885.

- Select a **Callout Shape**. There are six shapes to choose from.



When callout labels are used, the schedule numbers are included in the labels. Like other object labels, callout labels use the Text Style assigned to the layer they are on. See “Text Styles” on page 765.

Specify the label **Callout Size**.

- Select **Calculate from Text** for callout labels that are sized to accommodate the text within them.
 - Select **Size** and then type the radius in inches (mm). This radius will be used regardless of the size of the label text.
- 3 Additional **Label Text** options are available here.
 - **Label Prefix** - Specify the leading characters used in callout labels or when **Include Schedule #** is checked.

Columns to Include

Every schedule has a selection of **Columns to Include** on the Schedule tab of its **Schedule Specification** dialog. See “Schedule Tab” on page 881.

A complete list of the columns and objects available in the program can be accessed by selecting **Help> Contents and Index**  from the program menu and browsing to Schedules> Columns and Objects to Include on the Contents tab of the Home Designer Pro 2014 Help.

Columns and Quantity

It is important to remember that the number of columns you choose to include in a schedule influences the number of separate line items that will be listed in the schedule.

For example, if you have three paper birch trees in your plan and do not include columns that refer to the trees’ age, such as the Starting Age column, then the three trees will be listed in the same line item - even though one is young, one medium, and one adult.

Object Labels

Object labels can display in floor plan view for a variety of different object types based on one of several parameters:

- Automatic Labels provide basic information about the object, such as its type, size, or name.
- You can create a custom label for an object in its specification dialog using text. See “Label Tab” on page 885.

Automatic Labels

Most objects that can display labels have an Automatic Label created by the program that states basic information about it. When **Automatic Labels** is selected in the object’s specification dialog, this is usually the label that will be used; however:

- If a user-defined label is specified in the object’s defaults dialog, that label will be used instead of the Automatic Label.

- If a user-defined label is specified in the object’s specification dialog, that label will be used instead of the Automatic Label.
- If the object is a plant included in a schedule and callout labels are specified in that schedule, a callout label will be used.

Displaying Labels



The display of object labels can be controlled by layer in the **Layer**

Display Options dialog. Label layer names begin with the object type, followed by the word Label: for example, cabinet labels are located on the “Cabinets, Labels” layer. See “Layer Display Options Dialog” on page 104.

You can choose to suppress the label for an individual object on the Label tab of its specification dialog.

You can also turn the display of plant labels on or off in the **Plant Schedule Specification** dialog. See “Label Tab” on page 882.

Object labels use the Text Style assigned to each label’s layer. For example, cabinet labels use the “Cabinets, Labels” layer’s Text Style. See “Text Styles” on page 765.

The minimum on screen display size of labels can be specified in the **Preferences** dialog. See “Appearance Panel” on page 61.

With the exception of those for rooms, roofs, and cameras, labels can also be included in the Materials List, Master List and in the **Components** dialog. Items in the Labels column of the Materials List are editable; however, any changes will not be applied to the objects’ labels. See “Materials List Columns” on page 892.

Label Tab

The Label tab is found in the specification and defaults dialogs for a variety of different objects.

Note: If the selected object is a plant and you choose a callout shape in the Plant Schedule Specification dialog, the settings here are overridden and the schedule label is used instead. See “Label Tab” on page 882.

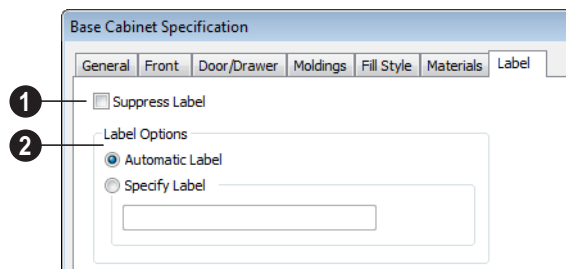

1 Most objects have a **Suppress Label** option. Check this box to suppress the selected object’s label in floor plan view.

Bay, Box and Bow Windows and Mulled Window units have several settings for controlling **Multiple Component** labels. See “Window Labels” on page 288.

- Select **Suppress All Labels** to display no label in floor plan view. Individual components are counted in the Materials List.

- Select **Show Component Labels** to produce labels for each component in floor plan view. Individual components are counted in the Materials List.
- Select **Show Single Label for Entire Unit** to produce one label for the unit and suppress component labels. When this option is selected, the settings that follow on the Label tab become enabled.

These settings also affect how Bay, Box and Bow Windows and Mullled Window units are counted in the materials list. See “Window Labels” on page 288 and “Displaying Mullled Units” on page 285.

2 Specify the desired **Label Options**, which control what information is contained in the label. Not available for cameras. See “Displaying 3D Views” on page 677.

- Select **Automatic Labels** to use the default label for the selected object. See “Automatic Labels” on page 884.

- Select **Specify Label** to replace the selected object’s Automatic Label with whatever you type in the text field below.

When Specify Label is chosen, the selected object’s Automatic Label initially populates the text field

- To use the selected object’s Component Code as its label, type %component_code%. See “Components Dialog” on page 901.

Materials Lists

Home Designer Pro can calculate a Materials List in three ways: **From All Floors, From Area, or From Room.**

Materials Lists can be created, edited, and printed directly from the program. They can also be exported as text, html or xls (Microsoft Excel) format files for use in other programs.



The Materials List is based on certain assumptions that may not match your building style. Home Designer Pro makes no representation as to the accuracy or reliability of the Materials List generated by Home Designer Pro. Always compare the Materials List with a manual take-off before providing a quote or ordering materials for a job.

Chapter Contents

- The Materials List Tools
- Creating an Accurate Materials List
- Organizing Materials Lists
- Materials List Display Options Dialog
- Materials List Columns
- Editing Materials Lists
- Managing Materials Lists
- Exporting the Materials List
- Conditioned Area Totals
- Structural Member Reporting
- The Master List
- Components Dialog

The Materials List Tools



Select **Tools> Materials List** to access the Materials List tools.

A Materials List is like a snapshot of the current plan at the time that the list is made. Any changes made to the model after a Materials List is generated are not included in that list. Create a new Materials List if you would like it to include these changes.

It is not necessary to wait until the plan is complete to generate a Materials List. In fact, you can create a series of Materials Lists reflecting costs at various stages of a project.



For comparison, generate Materials Lists with and without a proposed plan modification.

When you close a Materials List window, the program will ask if you want to save the Materials List. Type a name and click **Yes** to save the list or click **No** to close the list without saving it.

Calculate from All Floors



Select **Tools> Materials List> Calculate From All Floors** to generate a Materials List for the entire model.

Materials lists calculated from all floors can be lengthy, and only a portion of the list may display on your screen at one time. Use the scroll bars to scroll through the complete list. Move the pointer to cells in the list and click to make changes.

Calculate From Area



Select **Tools> Materials List> Calculate from Area** to produce a Materials List for the portion of a plan on a single floor that is included within a rectangular Materials Polyline.

To use Calculate from Area

1. Select **Tools> Materials List> Calculate from Area** .
2. Click and drag a rectangle around the area of the current floor that you would like to produce a Materials List for.
3. When the mouse button is released, a Materials List for the area within the rectangle will display.

Calculate From Area rectangles are temporary and do not display in floor plan view after the list is created.

Calculate From Room



To create the Materials List for a room, select the room, then select **Tools> Materials List> Calculate From Room**.

Calculate From Room  is also available on a selected room's edit toolbar. See "Editing Rooms" on page 233.

A Materials List calculated from a room is created for only the contents of that room: wall materials are not included.

Master List



Select **Tools> Materials List> Master List** to open the Master List, a list of previously used materials and any added information such as price or manufacturer. See “The Master List” on page 899.

Materials List Management



Select **Tools> Materials List> Materials List Management** to open a list of saved Materials Lists associated with the current plan. See “Managing Materials Lists” on page 896.

Creating an Accurate Materials List

In order to take full advantage of Home Designer Pro’s Materials List capabilities, there are several things to keep in mind.

- The accuracy of your Materials List is directly related to the accuracy of your model. Floor and ceiling heights, wall lengths, and structural settings all directly affect Materials List calculations.
- It takes more than just making your drawing look right to generate an accurate Materials List. If, for example, you use CAD lines to draw an item on a floor plan, that item will not be included in the Materials List. A better way would be to use a symbol or structural element.
- If you use custom materials, make sure their material definitions are set up correctly.

- Bear in mind that using generic objects like geometric shapes from the library to represent objects that aren’t available in Home Designer Pro can result in items being calculated in the Materials List in a manner that you might not expect.

Framing in the Materials List

You can specify whether framing materials are calculated by lineal foot, as a cut list, or as a buy list. See “Structural Member Reporting” on page 898.

For more information about how framing appears in the Materials List, see “Framing and the Materials List” on page 462.

Organizing Materials Lists

You can control what items are calculated in the Materials List by specifying which categories are used.

In addition, you can control how much information about each item is included by specifying which columns to display.

There are some parts of a model that cannot be excluded from the Materials List. Floor and ceiling platforms are prime examples. If you need to generate a Materials List for only part of a plan, such as an addition, consider making a copy of the plan file. In the copy, delete the as-built portion of the plan and then generate a Materials List.

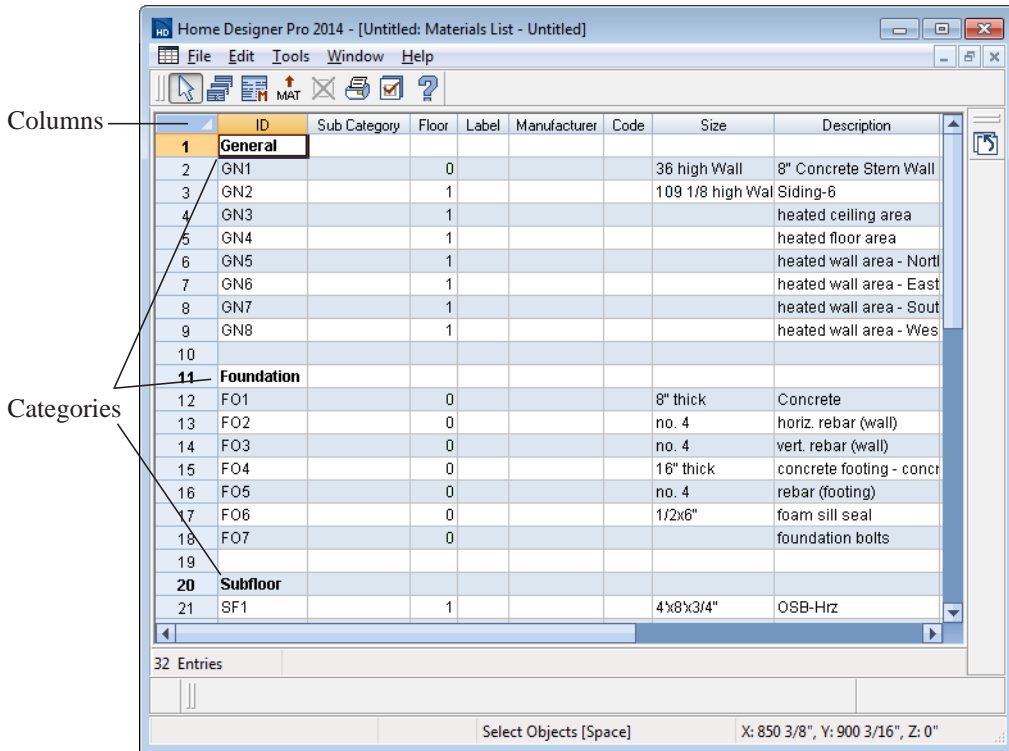

Categories

The line items in the Materials and Master Lists are organized into a set of predefined categories, such as Electrical and Framing, which display in the **ID** column.

You can specify which category each item belongs to in the Materials List and Master List. In addition, many items can be assigned to a category prior to generating a Materials List in the **Components** dialog. See “Components Dialog” on page 901.

To specify a line item's category

1. Create a Materials List, open the Master List, or open the **Components** dialog for a particular object.
2. Click in the cell in the ID column for a line item.
3. Select the desired category from the drop-down list that becomes available.

The categories that are available cannot be altered; however, you can specify which categories are included in the Materials List in either of two ways:

- Globally, in the **Preferences** dialog. See “Materials List Panel” on page 82.
- For individual lists in the **Materials List Display Options** dialog. See “Materials List Display Options Dialog” on page 891.

Subcategories

You can create any number of subcategories for each Materials List category in the **Preferences** dialog. See “Categories Panel” on page 85.

Items can be assigned to a subcategory in the Materials List and, for many items, in their object’s **Components** dialog in the same manner that they can be assigned to a category.

Materials List Columns

There are two ways to specify which columns are included in the Materials List as well as the order in which they display:

- Globally, in the **Preferences** dialog. See “Report Style Panel” on page 83.
- For individual lists in the **Materials List Display Options** dialog.

Materials List Display Options Dialog



When a Materials List or the Master List is open, select **Tools > Display Options** to open the **Materials List Display Options** dialog for the currently open list.

In the **Materials List Display Options** dialog for the Master List, only the Columns tab is available. See “The Master List” on page 899.

Categories Tab

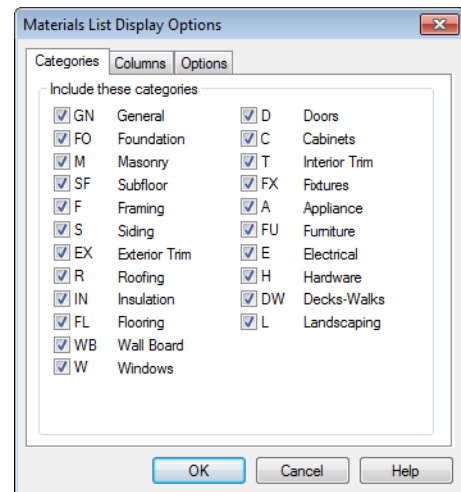

Check the box beside the name of each category that you want to include in the active Materials List.

These categories appear in the ID column in the order they are presented here.

The Materials List changes automatically to reflect any changes you make as soon as the **OK** button is clicked.

Note: The information in a suppressed category is still part of the Materials List. If the Materials List is exported, suppressed categories are exported, as well.

Columns Tab

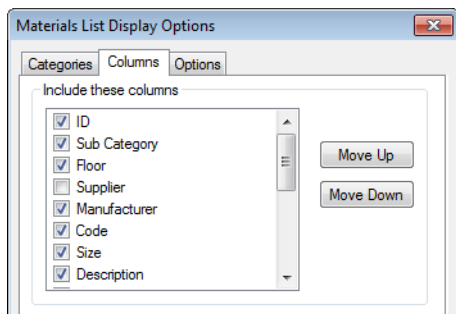

Check the box beside each column you want to include in the Materials List. You can suppress the column's display by removing the check next to the column name.

Columns appear in the Materials List in the same order that they display here.

Move Up - Click on a column name, then click this button to move that item up one place in the list.

Move Down - Click this button to move the selected column down in the list.

Options Tab

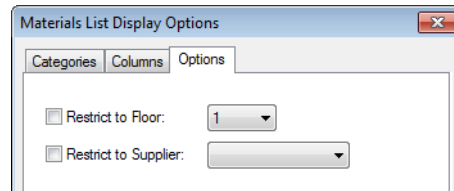

Check **Restrict to Floor** and select a floor number to restrict the Materials List to. When unchecked, the Materials List includes all floors.

If you plan to buy materials from multiple suppliers, you can create a Materials List for each. Check **Restrict to Supplier**, then choose a supplier from the drop-down list. The resulting materials list will include only materials to be purchased from that supplier.

Suppliers can also be added to the list in the **Components** dialog. See "Components Dialog" on page 901.

Materials List Columns

The columns in the Materials List, the **Components** dialog, and the Master List are very similar, but not all columns appear in all places.

The following lists the capabilities of each column.

Column Name	Available In	Editable In	Description
ID	Materials List, Master List, Components Dialog	Materials List, Components Dialog	Displays an automatically generated identifier for each line item. Select the cell in this column to change an item's category.
Use	Master List, Components Dialog	Master List, Components Dialog	Check boxes indicate if each item is included in the Materials List.
Sub Category	Materials List, Components Dialog	Materials List, Components Dialog	Select a cell in this column to change a line item's subcategory.
Floor	Materials List	N/A	States the floor that the line item is located on. See "Multiple Floors" on page 315.
Label	Materials List, Master List, Components Dialog	Materials List	Lists the label that displays in floor plan view for most items that have labels associated with them. See "Object Labels" on page 884.
Supplier	Materials List, Master List, Components Dialog	Materials List, Master List, Components Dialog	Specify a supplier for the item. A Supplier in the Master List is not used if one has been entered in the Components dialog.
Manufacturer	Materials List, Master List, Components Dialog	Materials List, Master List, Components Dialog	Specify a manufacturer for the item. A Manufacturer in the Master List is not used if one has been entered in the Components dialog.
Code	Materials List, Master List, Components Dialog	Materials List, Master List, Components Dialog	Specify a Code, such as a SKU, for the item. A Code in the Master List is not used if one has been entered in the Components dialog. The Code can also be used in a schedule or used as a label. See "Plant Schedules & Object Labels" on page 879.
Size	Materials List, Master List, Components Dialog	Materials List, Components Dialog	Click in a cell to edit the size description of the line item. To restore the original size, delete the text you typed in. For a blank cell, type a single blank space

Column Name	Available In	Editable In	Description
Description	Materials List, Master List, Components Dialog	Materials List, Components Dialog	Click in a cell to edit the description of the line item in the same way that the Size can be edited.
Quantity	Master List	Master List	Specify how many of an item must be found before information from the Master List is applied to it in a Materials List. If at least this many items are found, price, supplier, and other information is used.
Count	Materials List, Components Dialog	Components Dialog	This is the actual number of an item, either associated with the selected object or in the Materials List. Count can increased for accessories added to a selected object.
Extra	Materials List, Components Dialog	Materials List, Components Dialog	Specify an additional amount of the line item. Changes made in the Components are reflected in the Count column in the Materials List.
Unit	Materials List, Components Dialog	Materials List, Components Dialog	Indicates the units used to measure an item. When the unit is changed, the Quantity updates to reflect the change.
Price	Materials List, Master List, Components Dialog	Materials List, Master List, Components Dialog	This is the price of an item per unit. A Price in the Master List is not used if one has been entered in the Components dialog.
% Markup	Materials List, Master List, Components Dialog	Materials List, Master List, Components Dialog	Specify a markup percentage for the item. A markup in the Master List is not used if one has been entered in the Components dialog.
Labor	Materials List, Master List, Components Dialog	Materials List, Master List, Components Dialog	Specify a labor cost for the item. A Labor value in the Master List is not used if one has been entered in the Components dialog.
Equipment	Materials List, Master List, Components Dialog	Materials List, Master List, Components Dialog	Specify an equipment cost related to the item. An Equipment value in the Master List is not used if one has been entered in the Components dialog.
Total Cost	Materials List, Components Dialog	Materials List, Components Dialog	This is the total cost based on Count, Unit, Price, % Markup, Labor and Equip values.

Column Name	Available In	Editable In	Description
Default	Master List	Master List	Indicates which item is to be used as the default when more than one item is available. Click in this column to specify the line item as the default.
Comment	Materials List, Master List, Components Dialog	Materials List, Master List, Components Dialog	Additional information related to the item can be entered here. A Comment in the Master List is not used if one has been entered in the Components dialog. A Comment can also be used in a schedule.

Editing Materials Lists

Materials lists can be edited in a variety of ways. You can adjust the width of a column by clicking and dragging the bar on the right side of the column name.

Adding Information

You can enter information in the Price, Supplier, Code, Comment and Manufacturer columns for each item.

Adding price or other information for any item is straightforward. Simply click in the cell and type the desired information. When the information is correct, you can add it to the Master List. See “Adding to the Master List” on page 901.

You can switch between several existing suppliers or manufacturers for a given item by double-clicking on the right side of the cell in an appropriate column. A drop-down arrow displays to the left of the cell. Click it to view a list of suppliers or manufacturers for that item and select one.

When a Materials List is calculated, you can have the program search the Master List for Price, Supplier, and Code information for each item by selecting **Tools> Update From Master**. The information used is marked as “Default” in the Master List. See “Materials List Columns” on page 892.

Changing Information

Although the information in some columns cannot be saved to the Master List, you can change the information in any column in an individual Materials List. As with added information, click in a cell to select the existing text, then type in the desired text.

To move an item in a Materials List to a new category, select the cell in the **ID** column and choose a new category from the drop-down list that becomes available. You can also select a subcategory by clicking in the cell in the **Sub Category** column. See “Categories” on page 890.

Total Cost

Total Cost is calculated using the Count, Unit, Price, %Markup, Labor and Equipment columns to calculate the cost. The formula used is:

$$(\text{Count} + \text{Extra}) * \text{Price} * (1 + (\% \text{Markup}/100)) + ((\text{Count} + \text{Extra}) * \text{Labor}) + ((\text{Count} + \text{Extra}) * \text{Equipment})$$

If a column does not appear, 0 is used for the value of that column with the exception of Count and Price, which are always used in the calculation even if they are not shown.

Copying Information

Portions of a Materials List can be copied and then pasted into a **Text**  object or into

a word processing program or spreadsheet program using the standard Windows Copy (Ctrl + C), Cut (Ctrl + X), and Paste (Ctrl + V) commands. See “Copying & Pasting Text” on page 756.

Changing the Font

The font used for Materials Lists, the Master List and the **Components** dialog can be specified in the **Preferences** dialog. See “Font Panel” on page 64.

The size of the font used for Materials Lists, the Master List and the **Components** dialog can also be specified in the **Preferences** dialog. See “Report Style Panel” on page 83.

Managing Materials Lists



Select **Tools> Materials List> Materials List Management** to open the **Materials List Management** dialog, where you can access and manage a list of saved Materials Lists.

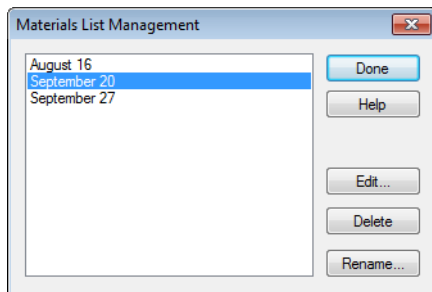

Click on the name of a saved Materials List in the list on the left to select it.

- **Done** - Close the **Materials List Management** dialog.
- **Help** - Open the Help Index to the page describing this dialog.
- **Edit** - Open the selected Materials List. You can also double-click an item in the list.
- **Delete** - Delete the selected Materials List.
- **Rename** - Open the **Rename Materials List** dialog and type a new name for the list.

Exporting the Materials List



Any Materials List can be exported into a text (.txt) file that can be opened directly by most spreadsheet programs. In a Materials List window, or in

the Master List, select **File> Export Materials List** to open the **Materials List Export Options** dialog.

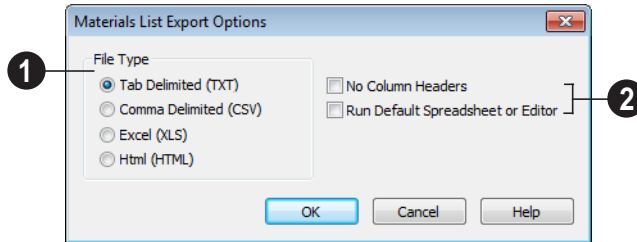

- 1 Specify the **File Type** that you would like to export to.
 - Select **Tab Delimited (TXT)** to create a text file with a tab between each field entry in the Materials List, and a carriage return between each row.
 - Select **Comma Delimited (CSV)** to create a text file with a comma between each field entry in the Materials List and a carriage return between each row.
 - Select **Excel (XLS)** to create a Microsoft Excel format file.
 - Select **HTML** to create an html file that you can view with your web browser.
- 2 Additional export options are available here.
 - Check **No Column Headers** to prevent column headings from appearing in the first row of the text file.
 - Check **Run Default Spreadsheet or Editor** to open the exported file with the program specified on your computer when you finish exporting.

When you click OK, the **Write Materials Export File** dialog will open. This is a typical File Save dialog. See “Exporting Files” on page 45.

Estimating Software

You can export a Materials List to a word processor or spreadsheet program to arrange it in your estimating format. You can also export the Materials List to a number of commercial estimating programs in whose databases you can keep your current pricing, labor costs, and markups and generate reports based on this data.

Before purchasing an estimating software program, be sure that the program supports the direct import of Home Designer Pro Materials Lists.

Any questions regarding estimating software packages and how they interact with Home Designer Pro should be directed toward the company providing the estimating software. Home Designer Pro is unable to provide any technical support for third party programs.

Conditioned Area Totals

The Materials List calculates the total areas of walls, floors, ceilings, doors and windows that separate the conditioned space in a plan from unconditioned space. This information is listed in the General category of the Materials List. See “Categories” on page 890.

Conditioned area totals can be entered into third party programs such as **REScheck** to determine whether the plan meets the energy code in use in your area.

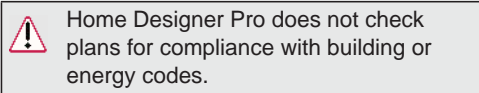

Walls, doors and windows are categorized as north, south, east, or west facing for the purposes of conditioned area totals. These directions are based on the orientation of the plan’s **North Pointer** . If no North Pointer is used, north is assumed to be

straight up on screen in floor plan view. See “North Pointer” on page 778.

If a wall is oriented at 45° or less to north in a plan, it will be categorized as a “North” wall. Any doors and windows in this wall will also be categorized as “North”.

Similarly, south-facing walls, doors and windows are categorized as “South” if they are oriented at 45° or less of south in the plan.

Walls, doors and windows oriented within 45° of either east or west will be classified as “East” or “West”, respectively.

The orientation of a curved wall is based on the direction of its chord. See “Drawing Arcs - Arc Creation Modes” on page 784.

Doors are always categorized as doors rather than as glass (windows). This is the case even when a door is specified as a Glass Door or when it is part of a mulled unit.

Structural Member Reporting



The **Structural Member Reporting** dialog allows you to specify the method used to calculate framing members in the Materials List.

To open the **Structural Member Reporting** dialog, select **Edit> Default Settings** , then select “Structural Member Reporting” from the tree list and click the **Edit** button. See “Default Settings vs Preferences” on page 56.

You can also open this dialog by clicking the **Structural Member Reporting**  button, which can be added to your toolbars. See “To add a button to a toolbar” on page 94.

You can create a list of the framing member sizes that you wish to purchase, and if an item in The Materials List is the same length as or shorter than one of these defined lengths, it will be described using the defined length rather than its actual length.

Structural Member Reporting Dialog

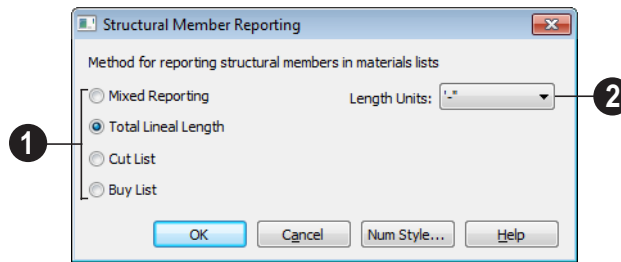

- 1** Choose a **Method for reporting structural members in Materials Lists**. The selected method will affect subsequently created Materials Lists, but not any that may already exist.
- Select **Mixed Reporting** to calculate framing materials using a combination of lineal lengths and piece counts.
 - Select **Total Lineal Length** to calculate the framing materials of the different structural components of the plan in linear feet.

- Select **Cut List** to calculate the framing materials of the different structural components of the plan by counting the individual pieces present in the model.
 - Select **Buy List** to calculate the framing materials of the different structural components of the plan by counting individual pieces and matching them to common board lengths.
- 2** Specify the **Length Units**, from the drop-down list. The unit or units selected are used in the Materials List when either **Cut List** or **Buy List** is selected as the method of reporting.

The Master List



Select **Tools> Materials List> Master List** to specify price, supplier, manufacturer, and other information for all of the items in your Materials Lists.

When a Materials List is calculated, click on a row number to select the row, then select **Tools> Update from Master** to have the program search the Master List for a record for the selected line item. If an identical record is available, its information is included in the Materials List.

- Multiple rows can be selected by clicking on one row number, then holding down the Shift key and clicking on additional row numbers.
- Select all rows by clicking the cell at the top left corner of the Materials List, above the row numbers.

If the Master List contains more than one record for an item, the program references the last one entered. You can override this by defining one specific entry as the default.

This is achieved by clicking on the check box in the Def column.

Home Designer Pro allows you to have more than one Master List. Only one can be active, however, and only the active list is updated with new information. You can specify which Master List is active in the **Preferences** dialog. See “Materials List Panel” on page 82.

 You should regularly back up the Master Materials List (mmaster.mat) or lists using Windows Explorer.

The **Master List** is almost identical to a Materials List, but has a few additional controls to help with viewing.

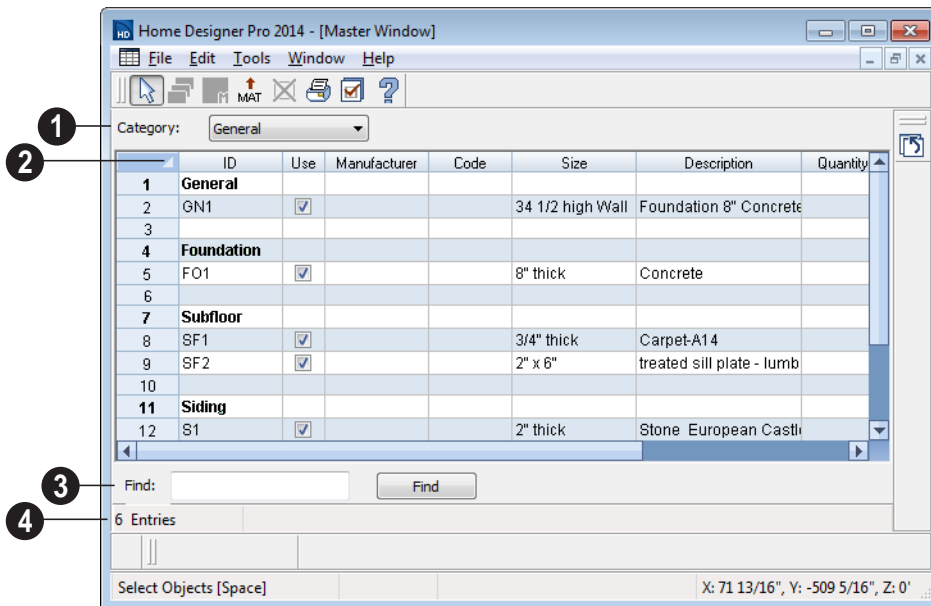

1 The **Category** drop-down list at the top left corner of the window lets you select one particular category for display, or all categories.

2 As with individual Materials Lists, you can specify which **Columns** display in the list. See “Materials List Display Options Dialog” on page 891.

3 Use the **Find** field near the bottom of the window to search for text in the Master List.

The search starts from the currently selected cell and moves to the right, then moves down to the next row starting at the left column, and so on, until it finds an instance of the text you entered.

4 The **Status Bar** at the bottom indicates how many entries are listed.

Adding to the Master List

You can add edited records in a Materials List to the Master List by selecting **Tools> Update to Master**.

To use Update to Master

1. Create a Materials List and make changes to any editable column of a line item.
2. Select the line item by clicking on the line number on the left side of the list. When selected, then entire line becomes highlighted.
3. You can select multiple adjacent rows by holding down the Shift key while clicking.
4. Select **Tools> Update to Master**. The information in the selected line is saved in the Master List.

Once Master List information exists for a particular item, you do not need to enter it again until you want to update it.

Similarly, items in a Materials List can be updated to include changes made to the Master List by selecting rows in the Master List, then selecting **Tools> Update from Master**.

Editing the Master List

In the Master List, existing line items can be modified or deleted. For information about

the editability of columns in the Master List, see “Materials List Columns” on page 892.

Often, the Master List will include items that you may not want to include in all Materials Lists.

- Checkboxes in the **Use** column indicate whether each item is included in the Materials List. If **Use** is unchecked, the item is not included. This is useful in cases where several line items will be purchased as a single unit.
- This **Quantity** column is used to specify how many of an item must be found before information from the Master List is applied to it in a Materials List. If at least this many of the item are found, price, supplier, and other information is used. **Quantity** is useful for applying a quantity discount.
- When more than one line item is available for a specific component or accessory, the **Default** column indicates which item is to be used. Click this column to specify this item as the default. This is useful when a line item has been updated to the Master List more than once with different price, supplier or other information.

To delete a row from the Master List, click on the row number at the far left. The entire row highlights. Select **Edit> Delete**, click the **Delete**  button, or press the Delete key on your keyboard.

Components Dialog



Many architectural objects in the program, from walls to cabinets to images, have components and accessories

associated with them that are calculated in the Materials List.

In addition to editing and adding information for objects and their accessories in the Materials and Master Lists, you can edit and add information directly to these objects in the **Components** dialog.

Select an object, then click the

Components  edit button to open the **Components** dialog for that object.

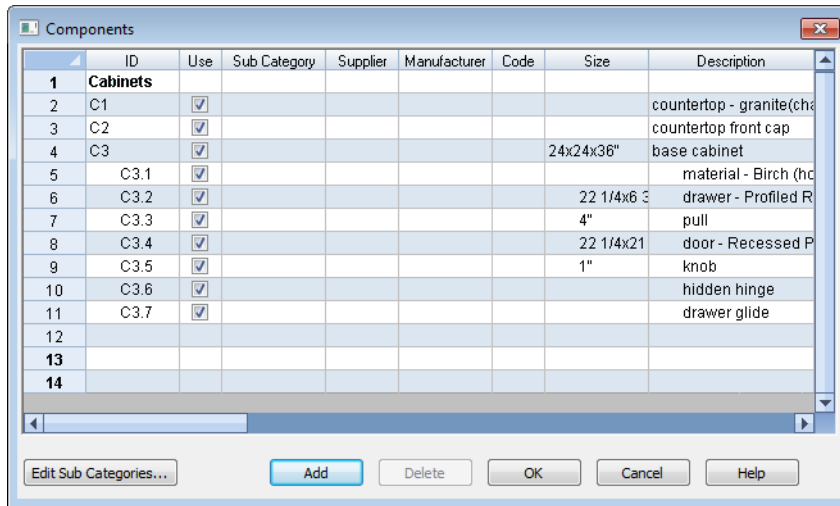

The information in the **Components** dialog is the same as the Materials List line item(s) for the selected object and can be edited in much the same way. See “Editing Materials Lists” on page 895.

Price, Supplier, Manufacturer, Comments, Code and Type information can be added and saved with the object itself. When that object is copied, even into a different plan, this information is transferred, as well, and will be calculated in the Materials List.

In addition to their components, cabinets also have subcomponents such as their doors, drawers and hardware. Subcomponent

You can also define the Components for a variety of items saved in unlocked categories of the Library Browser. When a library item is placed into a plan, its Components information goes along with it. See “Editing Library Objects” on page 625.

information in the ID, Size and Description columns is indented to help distinguish it from regular component information.

If the selected object has a label, information in the Code column can be displayed in the label. In the object’s specification dialog, select Specify Label and type the text macro %component_code%. See “Label Tab” on page 885.

Accessories

In the **Components** dialog, you can add additional Materials List entries to a selected

object. These user-created entries are called **Accessories**.

Note: Accessory quantities can only be edited when one object is selected. If multiple objects are group selected, accessory quantities are locked.

To create a new accessory

1. Select an object and click the **Components**  edit button to open the **Components** dialog.
2. Click the **Add** button and a new line is added to the spreadsheet.
3. The new entry is given an item name of **Accessory#**. You can give it any name you wish.
4. All other columns for accessory items except **ID** can also be edited.

5. To remove an accessory, click any part of its row and click the **Delete**  edit button.

To create a new cabinet sub-accessory

1. Select an object and click the **Components**  edit button to open the **Components** dialog.
2. Click in any cell in the row of the component with the Description that matches the cabinet type: base, wall or utility cabinet.
3. Click the **Add** button. A new line is added to the spreadsheet and its **ID**, **Size** and **Description** information is indented to denote that it is a sub-accessory.

Additional Resources

Home Designer Pro offers a variety of resources to help you become familiar with the many features it offers.

- Reference Manual
- User's Guide
- Home Designer Web Site
- Home Talk Online User Forum
- Technical Support

Reference Manual

The Home Designer Pro Reference Manual is a comprehensive source of information for Home Designer Pro 2014. Chapters are organized by subject, beginning with the fundamental concepts and progressing to the more advanced features. The Reference

Manual is presented in .pdf file format and includes a Table of Contents and Index. This manual is available online by selecting

Help > View Reference Manual  from the program menu.

User's Guide

Written for new Home Designer Pro users, but a helpful reference for users of all experience levels as well, the User's Guide features a series of tutorials designed to introduce the basics of using the program.

The Home Designer Pro User's Guide is organized by topic and walks you through

the process of creating a complete model, from the first wall to the interior design and landscaping.

This guide is available online by selecting **Help > View User's Guide** from the program menu.

Online Help Videos

Another resource designed to illustrate Home Designer Pro's powerful tools is the set of tutorial videos available on our web site.

To view the online videos, select **Help> View Online Help Videos** from the program menu or visit video.homedesigner.chiefarchitect.com/videos.

Home Designer Web Site

If you have questions that the Reference Manual and online Help feature have not answered, feel free to turn to the our web site.

A database of common technical support questions and answers related to supported

versions of Home Designer Pro is available through a searchable interface.

Select **Help> Visit Home Designer Web Site**  from the menu to launch your default internet browser to www.HomeDesignerSoftware.com.

Home Talk Online User Forum

The Home Talk Bulletin Board offers several ongoing discussions about a variety of topics related to the use of Home Designer Pro. It's rich with useful tips and available free of charge to all registered Home Designer Pro users.

- Discussions are initiated and carried out by users.

- Experienced users share knowledge with each other and beginners.
- Home Designer Pro Staff members post announcements, advice and technical information.

To visit the Home Talk forum, select **Help> Home Talk** or go to: HomeTalk.HomeDesignerSoftware.com.

Technical Support

Chief Architect takes pride in offering world class technical support services that can be accessed by telephone or on our web site. Select **Help> Technical Support** from the program menu to visit: www.HomeDesignerSoftware.com.

Before contacting Technical Support, take a moment to see if the answer to your question is found in the Reference Manual, tutorial videos, or in our on-line Help Database at www.HomeDesignerSoftware.com.

When you contact us, Technical Support will refer you to these resources if the answer can be found there.

So that our Technical Support specialists can assist you as efficiently as possible, please

refer to “Technical Support Services” on page 909 for additional trouble-shooting suggestions and information that will be needed before placing your call.

Upgrade to Chief Architect

Chief Architect is a premium, professional residential drafting and 3D design program that allows builders, architects and other professionals in the building and interior design trades to produce construction documents and high quality 3D renderings of their plans.

Chief Architect can open and edit plans created in Home Designer Pro. In addition,

Home Designer Pro can open plans created in Chief Architect for viewing, as well.

To learn more, select **Help > Upgrade to Chief Architect**. to launch your default web browser to www.chiefarchitect.com.

Technical Support Services

Chief Architect is committed to providing world-class technical support to complement our professional products.

The primary function of technical support is to make sure our software is functioning correctly and to help you quickly resolve problems that prevent its normal use. Our technical support professionals are eager to

work with you to make certain our software is functioning as designed.

We have also assembled a team of certified trainers offering instruction in the use of our software. Training is available via online seminars, online personal training, and on-site classroom seminars.

Reference and Training Resources

Chief Architect offers a variety of reference and training options in addition to the resources that come standard with the program.

Help Database

The Home Designer online Help Database contains a variety of articles describing how to resolve common technical problems and achieve specific design goals.

The Help Database is found in the Technical Support section of the Web site and can be referred to again and again at your convenience at www.HomeDesignerSoftware.com.

Video Training

Chief Architect has developed a collection of training videos that contain in-depth training on a wide range of topics from beginning to

advanced experience levels. These videos are available on our Web site, www.HomeDesignerSoftware.com.

Interactive Training

If you have questions about how to use Home Designer Pro, consider contacting our Training Department for a Personal Training session.

Personal Training is an excellent way to learn how to use the program, providing one-on-one interaction with a certified Chief Architect trainer via the internet. Discuss

topics that interest you and learn how to accomplish your specific design goals.

User Forum

Our Home Talk User Forum is a great place to discuss and exchange ideas with other Home Designer Pro users. Here you can post questions, read discussions from other users, and post suggestions to improve our product. In addition to our regular users, from time to time our support and engineering teams monitor the forum and provide input and discussion on current topics. This resource is available free of charge at HomeTalk.HomeDesignerSoftware.com.

Troubleshooting Common Technical Issues

Chief Architect strives to make certain our software works correctly; however, from time to time issues arise that prevent its normal operation.

Installation Issues

The following are common reasons for installation failure of Home Designer Pro and other software:

- Anti-virus software is enabled and interfering with installation. Anti-virus software is the most common cause of installation failures for any type of software. Refer to your anti-virus software's documentation for details on how to disable the software and re-enable it once installation is complete.
- The recommended minimum system requirements are not met. See "System Requirements" on page 7.

- The computer has a CD drive but not a DVD drive. A standard CD drive will not read DVD discs.
- The DVD has fingerprints, scratches, or other defects. Sometimes a small fingerprint can prevent the program from installing. Clean the disk with soft cotton cloth. Be sure to use soft cotton rather than paper products on disks to avoid scratching.



If you see visible cracking on a CD or DVD, do not insert it in your CD/DVD drive. Cracked disks can fly apart and cause damage to your drive.

- You do not have sufficient rights to install the software. Verify that you have administrative rights and the administrative password during the installation process. If you are on a corporate network, consult

your network administrator for assistance.

Refer to the on-line **Help Database** for solutions to common installation problems. If the answer to your question is not found there, contact our Technical Support department for assistance.

Emergency Transfer Message

When using Software Lock Security, you may receive an Emergency Transfer message when moving from one computer to another. To avoid this message, you must deactivate your license on the last computer on which you ran the program. See “Deactivating Home Designer Pro Licenses” on page 23.

If you must use the Emergency Transfer, type in the code you were given when you registered the program. See “Completing the Registration Wizard” on page 20.

Remember that you have a limited number of Emergency Transfers and that if you use

them all, you will need to purchase additional transfers from Chief Architect, Inc. You can avoid this expense by always deactivating your license before using it on a different computer, or by purchasing an additional license.



If you use an Emergency Transfer, your license will be immediately deactivated on the other computer.

Hardware Lock Not Recognized

If you are using Hardware Lock Security and your hardware lock is not recognized on startup, launch the **Hardware Lock Troubleshooter**. The Troubleshooter can diagnose and provide solutions to most common problems with hardware locks.

The Hardware Lock Troubleshooter can also be launched manually by selecting **Help > Hardware Lock Troubleshooter**.

Troubleshooting Printing Problems

Printing problems fall into two main categories: those that prevent the printer from working in any program and problems printing from Home Designer Pro. To determine if the problem is specific to Home Designer Pro, try the following:

1. Begin by clicking on the Windows **Start** button, and select **Printers**.
2. Right-click the printer that is not functioning properly in the **Printers** folder.
3. Click **Properties** from the menu that appears.
4. On the **General** tab, click the **Print Test Page** button.

If the printer does not produce a test page, the problem is not one that Chief Architect Technical Support can solve. Follow these suggestions:

- Check the connection between the computer and the printer.
- Check your printer documentation for troubleshooting printer problems.

- Contact your printer's manufacturer or check their Web site for support information.

Your printer manufacturer is the best resource for solving problems of this type. Chief Architect Technical Support is not able to help diagnose and solve problems that prevent printing from any program.



It is a good idea to keep the Owner's Manual for your printer or plotter close at hand. Write inside the Owner's Manual the various phone numbers for technical support for that printer or plotter – for the original manufacturer and for your local dealer.

Printers and plotters vary widely in how they function. Sometimes a faulty cable can be a problem. Other times, a plotter may require that the paper be loaded in a different orientation. Often, solving a printing problem is as simple as downloading and installing an updated printer driver. See “Printer Drivers” on page 843.

If you can print from Home Designer Pro but are not satisfied with the output, refer to “Printing & Plotting” on page 841 for information on how to set up and use the printing functions in the program. Legacy users should bear in mind that each release has new features and enhancements, so techniques that were used in prior versions may not work in the current version.

Make sure that you use **Print Preview**  before printing. Print Preview displays the printed paper, or drawing sheet, as a white rectangle on screen, and shows how the sheet is scaled and positioned relative to your drawing. If the drawing is not on the drawing sheet on-screen, it will not be on the sheet

when you print. See “Print Preview” on page 845.

Make sure that your scaling is correct for the paper size. If the plan is much smaller or much larger than the drawing sheet, you may need to change your Scale. See “Printing to Scale” on page 847.

64 Bit Versions of Windows

Some printers may not function correctly on 64 bit Windows operating systems. If you are experiencing a printing problem while using a 64 bit version of Windows, please contact the printer's manufacturer to verify that you have the correct driver installed.

Printing to a legacy parallel printer port on a Windows 64 bit machine may not work correctly when using a hardware lock. USB printers should not be affected. If you run into difficulty with this type of setup, you may want to consider Software Lock Security.

Clearing Printer Information

Some information specific to individual printers and plotters, such as available printer paper sizes, is saved with each plan and layout file.

If you are encountering problems when printing, or unexpected options in the **Page Setup** dialog, select **File> Print> Clear Printer Info** to clear the printer-specific information stored with the plan or layout file.

After using **Clear Printer Info**, select **File> Print> Page Setup** . Make sure the settings in the **Page Setup** dialog are correct, and then click OK and **Save**  the file.

Slow Printing from Layout

The most common reason for unusually slow printing from layout is the presence of a rotated view. To avoid this issue, rotate the view prior to sending it to layout, or change the orientation of the paper in layout so you do not need to rotate the view. See “Layout” on page 863.

Help Database

For answers to frequently asked questions regarding printing and other topics, select **Help> Visit Home Designer Pro Web**

Site  and browse the Technical Support section of our Web site, www.HomeDesignerSoftware.com. Our Technical Support specialists post new articles periodically to help resolve problems you may encounter.

Error Messages

Most common error messages have a known cause and simple resolution. When you encounter an error or warning message in Home Designer Pro, you can click the **Check Help Database** button in the message box to launch your default internet browser to the Home Designer Help Database on our Web site, www.HomeDesignerSoftware.com. If an article discussing the message is available it will display, providing information about the message and how best to avoid it.

It is important that abnormal errors be reported to Chief Architect Technical Support so that we can identify and resolve any problems.

The content of an error message is useful in diagnosing its cause. If you encounter an error message, read it carefully and write down the error number and the exact text of the error message.



Press the Print Screen key on your keyboard to capture a picture of the error message. Open a new word processing document or e-mail message and choose Edit> Paste to paste a copy of the error message into the document for later reference.

If you encounter the error more than once, make a note of your steps prior to receiving the message.

Before you report an error, check the Help Database to see if the error is already documented by typing the error message or part of the error message into the search form.

Finally, check to see if there are program updates available. These updates are provided free for the current version of Home Designer Pro and contain enhancements and other changes that allow the program to perform at an optimum level. Select **Help> Download Program Updates** from the Home Designer Pro menu to visit our Web site,

www.HomeDesignerSoftware.com, and follow the instructions.

Error Reporting

When an error occurs, you may have the option in the message box to send the report to Chief Architect.

No personal information is sent. When you click **Send**, your default internet browser launches and a Web page appears on screen. This message confirms that the report was sent successfully and may give you further instructions on how to proceed.

Contacting Technical Support

Before contacting Technical Support, take a moment to see if the answer to your question is found in the Reference Manual, Help index, or in our on-line Help Database. When you contact us, Technical Support will refer you to these resources if the answer can be found there.

Chief Architect's world-class technical support is available Monday through Friday from 6 AM to 5 PM Pacific Standard Time and can be reached at (208) 292-3375 or via our Web site, www.HomeDesignerSoftware.com.

There are several things you can do to ensure a speedy answer to your question when you contact Technical Support.

- Before contacting Technical Support, select **Help> About Home Designer Pro** and make a note of the first characters of your Product Key and the exact version of Home Designer Pro you are using. Technical support is available to the owners of software licenses. When you contact Technical Support, be prepared to verify that you are the owner of the software license.
- Before contacting Technical Support, check to see if there are program updates available for download. Our engineering

team periodically creates updates to the program to resolve functionality or program issues that were unknown at the time of release. These updates are provided free of charge for the current released version and can be accessed by selecting **Help> Download Program Updates** from the menu.

- When you first encounter a problem or error message, copy the exact wording of the message or a detailed description of the problem. This helps us isolate the problem and provide you with a solution as quickly as possible.
- When placing a call to Technical Support, be at the computer or work station that is experiencing the problem and have Home Designer Pro running. If you do not have access to the problem computer at the time of the call, the technician may be unable to reproduce the issue and/or suggest a remedy that can be implemented and verified immediately.
- Be prepared to reproduce the problem when you contact us. If the problem cannot be reproduced, there is a reduced chance that we will be able to resolve the problem on your first phone call.

Online Information

Home Designer Pro has a variety of support resources available on our Web site. These include our **Technical Support Help Database**, the **How do I...? Solution Finder**, downloadable program updates, and ways to contact our Technical Support department. To access these resources, visit: www.HomeDesignerSoftware.com.

Our support team is happy to assist you in finding the best resource to answer your questions, and can resolve most issues in just a few minutes. In order to allow us to quickly answer your calls, we ask that you limit yourself to one question per support call.

Online Support

Questions can be answered online by the Technical Support department. To submit a

technical inquiry online, visit the Technical Support section of our Web site and use the [Online Support Center](#).

This route ensures that your question is delivered to the first available support professional. Requesting assistance of an individual specialist is not recommended, since that person may not be available to answer your question in a timely manner.

Telephone Support

Our Technical Support team is committed to answering your questions as quickly as possible and in the order received. Your call is important to us; however, there are times when we get more calls than expected and you may have to wait a few minutes before speaking to a technician.

What's New in Home Designer Pro 2014

Welcome to Home Designer Pro 2014. This appendix has been written to help our upgrading customers make a smooth transition from earlier versions of Home Designer Pro to Home Designer Pro 2014.

Chapter Contents

- Before You Begin
- New and Improved Features by Chapter

Before You Begin

There are many new features in Home Designer Pro 2014, and many existing features have changed. These changes affect the way Home Designer Pro functions, so it is very important to be familiar with them.

- “Getting Started Check List” on page 918
- “For Files Created in Version 2012 and Prior” on page 920
- “For Files Created in Version 10 and Prior” on page 921
- “For Files Created in Version 9 and Prior” on page 921



Be sure to read this section before opening any plans created in earlier versions of Home Designer Pro.

Home Designer Pro 2014 can open the **.PL1**, **.LA1**, **.plan**, and **.layout** files from prior versions. Before opening any files created in earlier versions of Home Designer Pro, it is important to be aware of changes made in the newest version and the effect they may have on your legacy plan and layout files. For details, see “For Files Created in Version 10 and Prior” on page 921 and “For Files Created in Version 9 and Prior” on page 921.

As with any software, it is always best to finish any current projects you may have in progress in the version of the software in which you began them. If you do decide to bring a project forward, be sure to take the time to verify that everything in your drawing is correct when it is opened the new program version.

Getting Started Check List

The following checklist suggests steps you should take before migrating your files to Home Designer Pro 2014. More information about each of these steps can be found after the checklist.

- 1. Check for and Install Program Updates
- 2. Migrate Legacy Library Files
- 3. Migrate Custom Graphics Files
- 4. Review the New Features List
- 5. Review Your Preferences Settings
- 6. Set up Custom Toolbar Configurations
- 7. Backup Entire Plan
- 8. Check www.HomeDesignerSoftware.com for more information

1. Check for and Install Program Updates

Program updates contain improvements to the original release version and we recommend using the most current version available. By default, Home Designer Pro checks for program updates every day when you launch the program. For information about changing this, see “General Panel” on page 67. Please note that program updates are available for download, which means that you need internet access to acquire them.

You can check for updates at any time:

- Select **Help> Download Program Updates** from the menu.
- Visit the Program Updates page on the Home Designer Pro Web site at www.HomeDesignerSoftware.com.

2. Migrate Legacy Library Files

Library content from previous program versions cannot be installed or copied into the Home Designer Pro 2014 library. If you upgraded from version X1 or later and have custom library

content on your computer from that program version, the program installer will locate it and ask if you want to migrate it into the Home Designer Pro 2014 library. See “Migrating Library Catalogs” on page 20. TODO

You can import library files from versions X1 through 2012 at any time by selecting **Library> Import Library (.calib, .calibz)** from the program menu. In addition, library files from versions 7 and prior can be imported by selecting **Library> Convert Legacy (.alb) Library Files** from the program menu. See “Importing Library Catalogs” on page 612.

3. Migrate Custom Graphics Files

If you have custom graphics files, including textures, images or backdrops, that you were using in a previous program version, you can copy them manually using Windows Explorer for use in Home Designer Pro 2014. See “Home Designer Pro Data” on page 41.

- Copy custom texture files to the Home Designer Pro 2014 Textures folder located in the Home Designer Pro 2014 Data folder.
- Copy custom image files to your Home Designer Pro 2014 Images folder located in the Home Designer Pro 2014 Data folder.
- Copy custom backdrop files to your Home Designer Pro 2014 Backdrops folder located in the Home Designer Pro 2014 Data folder.

In Home Designer Pro 2012 through 8, custom graphics were saved in the Home Designer Pro Data folder, as they are in version 2014. In version 7 and prior, they were located in the program’s installation directory, in folders that began with “My”. Custom backdrops, for example, were saved in “My Backdrops”.

Texture and image files are not listed in the Library Browser. These files can be assigned to material and image objects, however, which are stored in the library so it is important to retain them. There are several tools available for adding materials and images to the library. For more information, see “Images” on page 806 and “Creating Materials” on page 637.

4. Review the New Features List

There are a number of important reasons why you should familiarize yourself with the new and improved features in Home Designer Pro 2014:

- New and improved features allow you to produce drawings more efficiently, so it is to your advantage to use them.
- Some changes to existing functionality may affect your accustomed drawing style and thus your productivity if you are not aware of them.
- New features may affect your choice of settings in your template files, as well as your preferred Preferences settings.

See “New and Improved Features by Chapter” on page 923.

5. Review Your Preferences Settings

Any changes that you made to the Preferences settings in your previous version do not migrate into Home Designer Pro 2014. You should review all the settings in the **Preferences** dialog to make sure that they are set to suit your drawing needs. For more information, see “Preferences Dialog” on page 60.

6. Set up Custom Toolbar Configurations

It is possible to migrate toolbar configuration files from previous versions to Home Designer Pro 2014; however, it is not recommended because it is likely that you will be missing new tools available in version 2014.

Instead, we recommend that you set up your custom toolbars the way you would like them in Home Designer Pro 2014. You may find it most effective to customize your toolbars as you get used to working in the new program version, rather than beforehand. See “Toolbar Configurations” on page 98.

7. Backup Entire Plan

Before migrating a legacy file created in Home Designer Pro 2012 or prior, it is a good idea to open the plan in the program version in which it was created and use the Backup Entire Plan tool (Export Entire Plan in version X3 and prior) to export the plan with all associated support files, including textures, backdrops and images. See “Backup Entire Plan” on page 52.

8. Check www.HomeDesignerSoftware.com for more information

If you have additional questions about the changes in Home Designer Pro, up to date information is available in the Support section of our web site. You can also post questions on the Home Talk web forum at HomeTalk.HomeDesignerSoftware.com.

For Files Created in Version 2012 and Prior

In addition to the above recommendations, if you wish to open files created in Home Designer Pro Version 2012 or prior, bear in mind the following before you open legacy files in Home Designer Pro 2014.

1. Roof Overhangs and Framing

In Home Designer Pro 2012 and prior, roof overhangs were measured to the outside of the subfascia, whereas in Version X5, they are measured to the outside of the fascia. In legacy plans opened in Version X5, this will not affect the appearance of roof planes in floor plan view because in 2012 and prior, roof plane polylines represented the projected framing area whereas in Version X5 they represent the total projected area. But, the position of the fascia and subfascia will shift, as will the length of the rafters. See “Eave and Gable Overhangs” on page 364.

2. Door Swing Direction and Materials

In Home Designer Pro X4 and prior, exterior doors that swing outward display interior material on exterior side of door. This was corrected in Version 2014. Doors modified to work around the old behavior could be affected in legacy plans opened in Version X5. See “Changing Door Swings” on page 260.

3. Door Swing Direction and Louvers

Improvements to door louver direction may affect louvers in all doors with the exception of bifold doors. See “Changing Door Swings” on page 260.

4. Wrapped Door/Window Lintels and Window Sills

In Home Designer Pro 2012 and prior, wrapped lintels and sills extended out further than those that were not wrapped. In legacy plans opened in Version 2014, the extents of wrapped lintels and sills will be adjusted so that they equal their **Extend** setting. See “Door Casing” on page 260 and “Window Casing & Sills” on page 290.

5. Invisible Beams

The legacy **Invisible Beam** checkbox was removed from the **Wall Specification** dialog. When legacy plans are opened in Version 2014, any **Invisible Beam** walls will be converted to Invisible Walls. See “General Tab” on page 214.

For Files Created in Version 10 and Prior

In addition to the above recommendations, if you wish to open files created in Home Designer Pro Version 10 or prior, bear in mind the following before you open legacy files in Home Designer Pro 2014.

1. Text Styles

The appearance of a number of objects that include text - including object labels, the North Pointer, Sun Angles, Joist Direction Lines, the Up/Down arrows for stairs and ramps - can now be controlled using Text Style. Their appearance may be altered somewhat in legacy plans opened in Home Designer Pro 2014. See “Text Styles” on page 765.

2. Light Sources

The illumination created by light fixtures and Added Lights was improved in Home Designer Pro 2014. Lighting in legacy plans may appear noticeably brighter when viewed in version 2014. See “Light Data Tab” on page 493.

For Files Created in Version 9 and Prior

If you wish to open files created in Home Designer Pro Version 9 or prior, bear in mind the following file management changes and structural enhancements before you open legacy files in Home Designer Pro 2014.

1. **Material textures, images, and backdrops**

Home Designer Pro 9 and prior installed with a catalog of library content, including a selection of material textures, images, and backdrops. This library catalog is no longer installed with the program because it is now available for download on-demand, so it will be possible to open a legacy plan in version 2014 and encounter numerous missing file warnings. To avoid this, we recommend using the **Export Entire Plan** feature in the original program version to create a folder that includes the plan and all associated textures, images, and backdrops before opening this file in 2014. This tool is renamed Backup Entire Plan in version 2014. See “Backup Entire Plan” on page 52.

2. **Floor and ceiling finish thicknesses**

In Home Designer Pro 9 and prior, floor and ceiling finish layers were not modeled in 3D, and objects such as railings, stairs, landings, cabinets, fixtures, and furnishings measured their Floor to Bottom height from the subfloor. These objects now measure their Floor to Bottom height from the floor finish surface, so it is possible that you may notice height changes for these objects - particularly in saved, annotated cross section/elevation views. See “Floor and Ceiling Platform Definitions” on page 322.

3. **Riser heights and landing thicknesses**

The default Best Fit Riser Height for stairs that do not reach the next level has been updated from 9” (225 mm) in version 9 and prior to 6 3/4” (169 mm) in Home Designer Pro 2014. This may affect the riser heights of stairs, as well as the thicknesses of landings attached to those stairs. See “Staircase Specification Dialog” on page 422.

4. **Auto Adjust Height**

The Follow Terrain option in some specification dialogs was replaced by the Auto Adjust Height checkbox. If a cabinet, fireplace, fixture, furniture, or other library symbol had Follow Terrain unchecked in version 9 or prior and was located in a room with a floor height other than the default for the current floor, then the object’s Floor to Bottom Height will change to equal that room’s floor height. The object’s position in the model will not change, however. See “Terrain Height vs Floor Height” on page 539 of the Reference Manual.

5. **Adjustable Thickness Walls**

In Home Designer Pro 9 and prior, generic, single-layer wall types were available for use. When a legacy plan file is opened in version 2014 and these wall types are detected, they are replaced by an updated, non-generic wall type. Framed walls and Railings will also acquire 1/2” (13 mm) thick layers of sheetrock on each side. Railings that define a Deck room with Advanced Deck Framing Built will not acquire sheetrock layers. See “Legacy Wall Types” on page 211.

6. **Stairwells defined by railings**

Interior railings that used a generic, single-layer wall type drawn in older program versions will acquire layers of sheetrock when the plan is opened in version 2014. This can affect the appearance of staircases where they join to a floor platform. To address this issue, select the railing and move it 1/2" (13 mm) away from the top edge of the staircase. See "Creating a Stairwell Manually" on page 420.

7. **Deck rooms**

In legacy plans opened in Home Designer Pro 2014, Deck rooms with Advanced Deck Framing built retain the framing but have Automatic Deck Framing turned off by default. Decks with no Advanced Deck Framing built are converted to Balcony rooms. See "Decks" on page 238.

8. **Structural Member Reporting**

When a plan created in Home Designer Pro 9 or prior is opened in Home Designer Pro 2014, Materials Lists are set to calculate **Total Lineal Length**. For a combination of lineal length and piece count, select **Mixed Reporting** in the **Structural Member Reporting** dialog. See "Structural Member Reporting" on page 898.

9. **Fill New Framing Members**

In Home Designer Pro 9 and prior, Fill New Framing Members was view-specific; in Home Designer Pro 2014 it applies to the entire plan. As a result, it is turned off by default in legacy plans opened in version 2014. See "CAD Defaults Dialog" on page 770.

New and Improved Features by Chapter

The following is a list of new and improved features in Home Designer Pro Version 2014. Where possible, cross-references to additional information has been provided.

Preferences & Default Settings

- The **3D Settings** dialog was renamed **3D View Defaults** and can now be accessed via the **Default Settings** dialog. See "3D View Defaults Dialog" on page 668.

Toolbars & Hotkeys

- Removed ability of multiple custom toolbars to share the same name. See "To create a new toolbar" on page 94.

Layers

- New "Casings, Exterior" and "Casings, Interior" layers for door and window casings. See "Displaying Doors" on page 257 and "Displaying Windows" on page 287.

Creating Objects

- When creating an object on a layer that is not turned on, you can now choose to **Cancel**. See "Object Creation and Layers" on page 114.
- Polyline- and Spline-based objects can only be created when their components have the same layer and display attributes

- including line style and color. See “Clicking and Dragging” on page 113.

Editing Objects

- Corner Boards and Quoins added to the **Delete Objects** dialog. See “Deleting Objects” on page 171.
- Can now delete Manual and Automatic Dimensions separately in the **Delete Objects** dialog. See “Deleting Objects” on page 171.

Walls, Railings & Fencing

- The Railing tab in the **Wall Specification** dialog was renamed to improve usability. See “Rail Style Tab” on page 224.
- Can now specify the height of bottom rail or shoe on Railings and Deck Railings. See “Rail Style Tab” on page 224.
- **No Shoe** and **Raise Shoe** settings were renamed **Include Bottom Rail** and **Raise Bottom Rail**. See “Rail Style Tab” on page 224.
- **Align With Above/Below**  edit tools now work with Invisible Walls. See “Aligning Walls Between Floors” on page 202.
- Legacy **Invisible Beam** checkbox was removed from the **Wall Specification** dialog. Invisible Beam walls in legacy plans will be converted to Invisible Walls when opened in version 2014. See “General Tab” on page 214.

Rooms

- Improved feedback in the **Room Specification** dialog if the selected room

has multiple rooms with different floor heights located directly above it. See “Structure Tab” on page 245.

- The General tab of the **Room Defaults** dialogs had no active settings, and Materials tab’s settings caused confusion, so both were removed from the dialog. See “Floor and Room Defaults” on page 230.

Doors and Windows

- Can now display door and window casing in floor plan view. See “Displaying Doors” on page 257 and “Displaying Windows” on page 287.
- Can now specify the **Depth** of door and window casing. See “Casing Tab” on page 269 and “Casing Tab” on page 297.
- New “Casings, Exterior” and “Casings, Interior” layers. See “Displaying Doors” on page 257 and “Displaying Windows” on page 287.
- Can now specify wrapped lintels and sills on windows with recessed casing. See “Lintel Tab” on page 271 and “Lintel & Sill Tab” on page 299.
- Improved usability of **Extend** setting for lintels and sills. See “Lintel Tab” on page 271 and “Lintel & Sill Tab” on page 299.
- New **Reverse Interior/Exterior** option in the **Door Specification** dialog. See “General Tab” on page 266.
- New **Hardware on Fixed Section** option in the **Door Specification** dialog. See “Hardware Tab” on page 276.
- Improved how Bi-fold doors, their hinges, and their louvers are generated. See “Bifold Doors” on page 255.

- Can now show Bi-fold doors as open in 3D views. See “Displaying Doors” on page 257.
- New **Show in Plan** setting lets you control the display of the concrete cutout for doors and windows in floor plan view. See “Displaying Doors” on page 257 and “Displaying Windows” on page 287.
- Improved **Louwer direction** behavior for doors.
- Improved how door materials are handled with the swing side is changed. See “Door Sides” on page 260.
- New **Fit Frame to Wall** setting lets you specify that a window frame adjusts to fit the wall type that the window is placed in. See “Sash & Frame Tab” on page 301.
- Improved display of window frames and sills in floor plan view. See “Displaying Windows” on page 287.
- Windows can now have a lintel without also having a sill. See “Window Casing & Sills” on page 290.

Foundations

- New **Show in Plan** setting for doors and windows lets you control the display of their concrete cutout in floor plan view. See “Displaying Doors” on page 257 and “Displaying Windows” on page 287.
- Increased the default **Add for Rough Opening** value for fireplaces to 2” (50 mm) on each side and the top. See “General Tab” on page 345.

Roofs

- In floor plan view, roof plane polylines now reflect the thickness of the fascia and

shadow boards rather than the extents of the framing. See “Eave and Gable Overhangs” on page 364.

- Can now specify eave and gable overhangs for Auto Dormers. See “Dormer Specification Dialog” on page 391.
- Can now specify the on center **Spacing** of rafters for individual roof planes in the **Roof Plane Specification** dialog. See “Framing Tab” on page 362.
- New **No Special Snapping** option prevents roof planes from snapping to wall exteriors. See “General Tab” on page 372.
- Redesigned **Change Roof Pitch or Height** dialog. See “Change Roof Pitch or Height Dialog” on page 369.
- Roof Baseline Polylines can now be copied and pasted. See “Roof Baseline Poly-lines” on page 375.

Stairs, Ramps & Landings

- No Shoe for Rail setting was renamed **Include Bottom Rail on Landings** for greater clarity. See “Railing Tab” on page 427.



Framing

- The bottom plates of framed interior walls are now specified as **Treated** if built on a monolithic slab foundation. See “Treated Sill Plates” on page 437.
- **Posts**  now use their default size when placed under a floor or ceiling beam instead of inheriting the beam’s width. See “Post” on page 440.

Electrical

- Improved how **Auto Place Outlet**  tool positions outlets for appliances. See “Auto Place Outlets” on page 489.

Trim & Moldings

- New **Auto Place Corner Boards**  and **Auto Place Quoins**  tools. See “Corner Boards” on page 498 and “Quoins” on page 500.
- Corner Boards and Quoins added to the **Delete Objects** dialog. See “Delete Objects Dialog” on page 171.

Cabinets

- New **Specify Appliance** setting allows multiple front appliances in the same cabinet. See “Front Tab” on page 526.
- Can now assign multiple door and drawer styles to a single cabinet. See “Front Tab” on page 526.
- New “Double False Drawer” option for cabinet fronts. See “Front Tab” on page 526.
- Drawers and Double Drawers automatically change to False Drawers when a cooktop appliance is inserted into a cabinet. See “Built-In Appliances” on page 511.
- “Plain” cabinet doors renamed “Slab” cabinet doors. See “Door/Drawer Tab” on page 529.

Other Objects

The Library

- New **Update Library Catalogs** option checks for updated Core, Manufacturer, and Bonus Catalogs content. See “Library Content” on page 609.
- Improved the appearance of doorways added to the library in the Selection and Preview Panes. See “The Library Browser” on page 604.

3D Views

- **3D Settings** dialog was renamed **3D View Defaults** and can now be accessed via the **Default Settings** dialog. See “3D View Defaults Dialog” on page 668.
- Backdrop name now displays in **3D View Defaults**. See “3D View Defaults Dialog” on page 668.
- New Plan Display tab in **Camera Specification** dialogs allows control of camera symbol size, Clip Plane Indicator length, and focal point display.
- New Label tab in **Camera Specification** dialogs. See “Displaying 3D Views” on page 677.
- **Wall Elevation**  tool now recognizes room definition created by invisible walls and railings. See “Cross Section/Elevation Camera Tools” on page 676.
- Can now modify a saved camera without saving your changes. See “Activating Saved Views” on page 690.
- Can now save **Cross Section Slider** settings with saved cameras. See “Cross Section Slider” on page 686.

- New position text field in **Cross Section Slider** dialog. See “Cross Section Slider” on page 686.

Dimensions

- New **Auto Interior**  tool. See “Auto Interior Dimensions” on page 731.
- Can now delete Manual and Automatic Dimensions separately using the **Delete Objects** dialog. See “Delete Objects Dialog” on page 171.
- Improved how dimensions locate door and window casing. See “Locate Objects Tab” on page 723.
- Can now specify whether and how furniture is located by dimensions. See “Locate Objects Tab” on page 723.

Pictures, Images, & Walkthroughs

- New **Create Walkthrough Path**  tool with editable Key Frames. See “Create Walkthrough Path” on page 819.

- The **Resize Picture**  edit tool is now available for selected metafile boxes and pdf boxes, and was renamed **Point to Point Resize**. See “Point to Point Resize” on page 818.

Importing & Exporting

- Can now specify whether imported .dxf/.dwg drawings are placed at their original location or at the origin (0,0). See “Drawing Unit” on page 832.

Printing & Plotting

- The default **Print Range** in the **Print** dialog is now **All** by default and your last choice for this setting is remembered between program sessions. See “Print Dialog” on page 855.

Index

Numerics

3D	
Backdrops	671
Close all 3D Views	680
Data Import.....	836
Delete Surface	679
Remove 3D Data.....	680
Symbols, Importing	838
3D Roof Designer	365
3D View Defaults Dialog	668
3D Views	
Display	677
Doll House.....	674–675
Editing.....	687
Framing Overview	675
Full Overview	674
Generation, Speed up	716
Line Weights.....	849
Overviews.....	673
Panels	670
Save.....	690
Working in	687
3D Wall Designer	189

A

Absolute Location	
New point	773
Added Lights	700
Adding	
Floor Between Existing Floors.....	318
to the Library	613
Toolbar Buttons	93
Adjust	
Material Definition	637

Wall Angle	73
Adjust Lights Dialog	704
Advanced	
Deck Framing.....	239
Aerial View	660
Alcove Roofs	384
Align	
Curved Stairs Between Floors	157
Curved Walls Between Floors	203
Objects	154
Pony Walls Between Floors.....	203
Roof Edges	366
Stem Walls and Footings	337
Walls	201
Allowed	
Angles Dialog.....	170
Alpha Channel	648
Alphabets	
International	745
Unicode	745
Ambient Light	
Daytime	700
Interior	700
Nighttime	700
Angle Snaps	111
Angled Front Cabinets	522
Angles	
Entered as bearings.....	779
Angular Dimensions	162, 729, 739
Appearance Preferences	61
Appliances	
Built into cabinets	511
Outlets, where placed	491
Arc	
Creation Modes	784
Specification Dialog	786

Tab.....	787
Tools	785
with Arrow.....	786
Architectural Blocks	597
Components.....	600
Displaying.....	599
Edit Sub-Objects	599
Explode	599
Sub-objects.....	600
Architectural Preferences	73
Archive Files	47
Arcs	
Aligning Centers.....	156
Arc About Center.....	784
Arc Creation Modes	784
Show Arc Centers	134
Start and End Points.....	77
Area	
Living Area calculation.....	235
of a Polyline	791
of Roof Planes	374
of Rooms	237
Arrange	
All.....	660
Icons	660
Arrow	
Auto Positioning	758
Tab.....	783
Text Line With.....	758
Artwork	
Creating textures.....	639
Attenuation	496
Attic	
Floor.....	327
Rooms.....	235
Trusses	477
Walls	206, 216
Auto	
Archive	46
Check for Program Updates	68
Dormer Tool.....	389
Dormers, Editing	390
Floating Dormer	388
Floating Dormer Tool.....	388
Interior Dimensions	731

Place Corner Boards.....	498
Place Outlets.....	236, 489
Place Quoins.....	500
Roof Returns	393
Save Files	47, 68
Stairwell	419
Auto Dimension	
Defaults	727
Auto Rebuild	
Floors & Ceilings	324
Foundation	336
Framing.....	438
Roofs	355
Terrain	552
Automatic	
Exterior Dimensions.....	730
Framing.....	438
Roofs	350
Roofs vs. Manual Roofs	350

B

Backclipped Cross Section	676
Backdrops	698
3D.....	671
Definition.....	698
in Rendering Techniques.....	672
Panoramic.....	698
Background Color	63
Backup	
Entire Plan	52
Files.....	45
Balloon Through Ceiling	217
Balusters	224
Definition.....	399
Base	
Cabinets.....	509
Baseline	
Polylines (Roofs)	375
Roofs	363
Basements	
Daylight.....	340
Walkout.....	340

Bay Windows	281
Bay/Box Window	
Specification Dialog.....	311
Beams	
Floor/Ceiling	442
Roof	441
Roof, exposed.....	590
Bearing Line	456
Bearings	779
Behaviors Preferences	78
Birdsmouth	
Cut.....	371
Blend Colors with Materials	633
Blind Cabinets	522
Blocking	
Joist	442
Roof	441
Wall.....	447
Blocks	
Architectural	597
Bonus	
Library Catalogs.....	610
Rooms.....	327
Bow	
Window Specification	313
Bow Windows	281
Box	
Tools.....	794
Windows.....	281
Break	
Line.....	158
Line, complete	159
Line, partial.....	159
Terrain Breaks	544
Wall.....	189
Build	
Foundation	319, 334
Framing Dialog	443
House.....	800
New Floor	317
Roof Dialog.....	355
Terrain	552
Bumping/Pushing	152

C

Cabinet

Defaults	507
Designer	507
Modules Library.....	510
Shelf Specification Dialog	532
Specification Dialog	522
Tools	509

Cabinets

Angled front	520
Backsplash	524
Base	509
Bevel	531
Blind	522
Built-in appliances	511
Corner	520
Countertop, custom	510, 513
Countertops	513
Delete face items.....	528
Dimension to corners/sides	725
Door/Drawer Overlay	528
Door/drawer style	510
Doors, diagonal.....	528
Doors, glass.....	531
Editing	517
End cabinets	520
Fillers	511
Frameless	528
Front Indicators	514
Front Tab	526
Full Height	509
General Defaults	508
Glass doors.....	531
Island.....	522
Labels.....	515
Lazy Susan	529
Minimum Width.....	509
Module Lines.....	514
Module lines, partial	509
Moving, with Wall	518
Normal.....	520
Opening Indicators	514
Outlet placement	491
Peninsula radius.....	520
Radius end.....	520
Resize Increment	509

Reverse Appliance	529	Loan	802
Separation	528	Materials on soffits.....	592
Shaped	520	Callout	
Shelves	532	Arrows	759
Special shapes.....	520, 523	Defaults	744
Stile.....	528	Shape	760
Toe kick.....	524	Size	760
Wall.....	509	Specification Dialog	760
CAD		Callouts	759
Angle Snaps	111	Camera	
Angles in Degrees/Bearings.....	770	Activating	690
Box.....	794	Change Settings	691
Circle about center	789	Clip Surfaces Within	667, 695
Circle Tools.....	788	Create Views.....	673
Convert to Terrain	573	Defaults	665
Cross box	794	Field of View	666, 686
Current Point.....	774	Height above floor	666
Delete Current Point.....	775	Move Increments	666
Drawing Tools	771	Move Tools.....	682
Ellipses.....	789	Move Up/Down One Floor	685
Fillet	159	Orbit Tools	682
In Layout.....	868	Plan Display Tab	693
Line Length Format	770	Remove Wall within	667, 693
Lines	776	Restrict to room	669
Move to Front of Group.....	151	Rotate Increments	666
Ovals	789	Specification Dialog	691
Points, moving	775	Tilt Angle.....	666
Polylines.....	790	Tilt Tools	683
Preferences	74	Tools.....	682
Rectangular Polyline Tool	794	Cascade Views	657
Resize	78	Casing	
Rotate around	78	Door.....	260, 269
Rotate items.....	78	Ignore for opening resize.....	58
Rotate Jump	78	Window	290
Temporary Points	774	Cathedral Ceilings	242
to Walls	164, 208	Ceiling	
Toolbar Configuration	98	Break Lines	243
CAD Box		Framing.....	443
Specification Dialog.....	795	Heights	239
CAD Defaults	770	Plane	352, 379
CAD Objects		Trusses.....	470
Converting	164	Ceiling Finish Dialog	324
Dimensions to	726	Ceiling Plane	
Displaying.....	798	Specification Dialog	380
Calculate		Ceiling Structure Definition	323
From All Floors.....	888		
From Room.....	888		

Ceilings	
Automatic	443
Basement	332
Cathedral	242
Coffered	244
Dropped	241
Lowered	241
Over this room	247
Special	241
Stepped Trusses	478
Tray	243
Vaulted	242
Center	
Doors	259
Object edit tool	156
Sheet	846
Snapping to	80
Chamfer	
Footings	220
Two Lines	160
Change	
Door Swings	260
Floor/Reference	326, 328
Line to arc	405
Roof Pitch or Height Dialog	369
View Panel Factors	717
Wall Types for Pony Walls	185
Check	
Plots	842, 847
Child Buttons	94
Chimneys	347
Circle	
Specification Dialog	789
Tools	788
Circles	
Aligning Centers	156
Circle about center	789
Draw using center and radius	789
Ovals	789
Clear Terrain	540
Clear the Terrain	540
Click Stairs	398
Close	
Plans and Views	53
Program	54
Views	661
Color	
Displaying images & pictures	63
Off/On	149
Color Chooser	652
Dialog	652
Eyedropper	652
Compatibility	
with other programs	40
Components	627
Dialog	901
Compound Raked Walls	208
Concentric	
Resizing	122
Configurations Tab	97
Connect	
Electrical	488
Walls	191
Contextual Menus	61
In Render views	685
Contour Lines	551
Contours Tab	555
Convert	
CAD Lines to Terrain Data	573
CAD Objects	164
Polyline	165
Special Polylines into Polylines	166
Copy	
Floors	320
Folders and Library Objects	616
Region as Picture	819
Views	871
Copy/Paste	
Main Edit Mode	116
Sticky Mode	116
Corner	
Boards	498
Windows	282
Corner Board	
Specification Dialog	499
Countertops	
Custom	510, 513
Edge Profiles	520
Edit Custom	519

Create
 New Plan Dialog 42
 Plant Image 574

Cross Hairs 76
 Mouse 154
 Toggle On/Off 154

Cross Section Lines
 Callouts 761
 In Camera Views 689

Cross Section Slider 686

Cross Section/Elevation Camera
 Specification Dialog 694

Cross Section/Elevations 673
 Create 675
 Detailing 677
 Sent to Layout 870

Crown Molding
 Cabinets 519

Current
 CAD Point 774
 Floor 326
 Floor, Delete 320

Curved
 Deck Edge 182
 Deck Railing 182
 Stairs 398
 Walls, Draw 190

Custom
 Countertops 510, 513
 Countertops, Editing 519

Custom Countertop
 Specification Dialog 535

Custom Light Intensity Dialog 495

Customize
 Sheet Sizes Dialog 852
 Toolbars 29, 93

D

Deck
 Advanced Deck Framing 239
 Designer 182
 Edges 182

Framing 239, 248
 Planking 248
 Railing 182
 Railing Defaults 180

Decks 182, 238

Default
 Lights 700
 Wall Heights 217

Default Sun Light
 Specification Dialog 707

Defaults
 Auto Dimensions 727
 Cabinet 507
 Camera 665
 DeckRailing 180
 Defined 56
 Dimension 719
 Door 253
 Dormer 351
 Dynamic 57
 Electrical 486
 Fencing 180
 Floor 230, 316
 Foundation 330
 Framing 436, 443
 General Plan 58
 Layout 863
 Material 651
 Railing 180
 Reset 59
 Roofs 351
 Room 230
 Settings 56
 Structural Member Reporting 898
 Wall 177
 Window 280

Define Material Dialog 644

Delete
 3D Surface 679
 Built-in Fixtures and Appliances 627
 Current Floor 320
 Current Point 775
 Floors 320
 Foundation 338
 Framing 461
 Gable Over Opening 384

Library Content	617	Drawing Groups	150
Objects	171	Drawing Sheet	845
Objects, warning before	58	Electrical	490
Roof Planes	353, 371	Foundations	335
Temporary Points	774	Images	807
Tools from Toolbars	94	Line Angles	75
Wall Hatching	188	Line Length	75
Details		Objects	102
Cross section/elevations	677	Options, Layout	872
Dimension		Pointer CAD Coordinates	62
Defaults	720	Pony Walls in Floor Plan View	194
Tab	740	Roof Planes	364
Tools	728	Room labels	237
Dimension Defaults	719	Temporary Dimensions	731
Dialog	720	Terrain	551
Dimension Line		Walls, Railings, and Fences	192
Specification Dialog	739	Distributed Object Tab	563
Dimensions		Divided Lites see Lites	
Angular	162, 729, 739	Doll House View	674–675
Auto Interior	731	Door	
Display size	63	Casing	260
Editing	733	Defaults	253
To electrical items	725	Specification Dialog	265
End to end	729	Swing Angle	266
Exterior	730	Tools	254
Interior	730	Trim	260
Interior, minimum area	728	Doors	
Locate Objects	723	Arched	274
Locating railings	216	Bifold Doors	255, 263
Minimum Interior Area	728	Casing	269
Move Objects Using	737	Center	259
Moving Labels	734	Change Opening/Hinge Side	261
Number Height	740	Change Swing Side	262
Overall	728	Doorways	255
Point to point	730	Double-swing	269
Printing	851	Frame	273
Rounding Method	721	Framing	448
Tape Measure	732	Gables Over	382
Temporary	731	Garage	256
Wall Layers	210	Garage, opening direction	263
Wall Widths	740	Garage, panels	269
Zeroes in	723	Glass, muntins	273
Display		Handles	276
3D Views	677	Hardware	276
Arc Centers and Ends	771	Hinged Doors	255, 261
CAD Objects	798	Hinges	276
		Labels	258

Tolerance	77	To-End Dimensions	729
Egress Windows	296	Trusses.....	480
Electrical		Energy Heel	476
Auto Place Outlets	489	Enhanced Metafiles	814
Connections.....	488	Enter	
Defaults.....	486	Coordinates	778
Deleting.....	491	Error Messages	913
Dimension to.....	725	Estimating Software	897
Dimensions to.....	726	Exit Program	54
Displaying.....	490	Expand/Collapse All	608
Editing Objects.....	490	Explode	
General	485	Architectural Blocks	599
Labels	490	Dormers.....	391
Library.....	489	Export	
Lights	487	2D Drawings	833
Outlets	487	All Floors	833
Switches.....	488	Current View	833
Tools.....	487	Drawing File Dialog	834
Wiring.....	488	EMF.....	815
Electrical Service		From the Library.....	620
Specification Dialog.....	492	Layout Files	875
Elevation		Materials List.....	897
Data Tools	540	Picture Files	811
Points.....	541	Windows Metafiles.....	815
Regions.....	543	Windows Metafiles Dialog	815
Splines	543	WMF.....	815
Tab	559	Extend	
Elevation Data		Slope Downward	204
Import DXF	572	Extension Lines	
Importing from DXF.....	572	Adding	735
Tools.....	540	Deleting	737
Elevation Line		Edit Extensions tool	734
Specification Dialog.....	559	Editing	735
Elevation Point		Extension Snaps	111
Specification Dialog.....	557	Extensions Tab	726
Elevation Region		Exterior	
Specification Dialog.....	559	Dimensions	730
Elevations		Room types.....	235
Create	675	The Exterior Room	232
Interior.....	673	Walls	183
Ellipse	789		
Specification Dialog.....	789		
End			
Cabinets.....	521		
Caps	75		

F

F6 Key

Fill Window 655

Faster Rendering 716

Fence Designer 183

Fencing 183

Defaults 180

Field of View 666, 686

File

Backing Up Your Files 45

Create New 42

Management 39

Menu, Recent File List 69

Open 48

Organization 40

File Management Preferences 68

Fill

Patterns 792

Window 655

Window Building Only 655

Fill Style Tab 792

Fillet 123

Two Lines 159

Fillet/Chamfer Dialog 160

Filter

Library Search 609

Library Tree View 618

Final View 698

with Shadows 698

Find Plan Wizard 50

Fire Box Tab 346

Fireplace

Direction facing 344

Interior wall 344

Library 347

Masonry 344

Prefabricated 347

Specification Dialog 345

Symbol 347

Fireplaces 343

Chimneys 347

Foundations 344

Freestanding 344

In walls 344

Types 343

Fix

Connections 192

Roofs 353

Fixture/Furniture Resize 59

Fixtures

Lights 487

Flare/Curve Stairs 410

Flat Region 546

Specification Dialog 560

Floating Auto Dormer 388

Floor

3D Overview 673

Build New Floor 317

Camera 672

Defaults 230, 316

Export all 834

Export current 834

Framing 443

Heights 239

Overview 673

Tools 317

Trusses 470

Floor Plan

Drawing 33

View 35

View Template (Print Model) 860

Floor Structure Definition 323

Floor/Ceiling

Beam 442

Floor/Ceiling Truss

Specification Dialog 482

Floors

Adding 317

Attic 327

Change Floor/Reference 326, 328

Copying 320

Current Floor 326

Deleting 320

Floor Up/ Floor Down 326

FloorTabs 443

Insert New Floor 318

Maximum number 315

Raised.....	241	3D Overview	675
Reference Floor	327	Auto Rebuild	438
Swap Floor/Reference	328	Automatic.....	438
Folders Preferences	69	Barge Rafter	453
Follow Terrain	555	Beams	449
Font		Bearing Line.....	456
Materials List	64	Build Framing Dialog	443
Preferences	64	Butt Joints.....	443
Fonts	745	Ceiling	443
and Alphabets.....	745	Cross Box.....	794
Footings		Deck	239, 248
Alignment	337	Defaults	436
Chamfer	220	Defaults Dialog.....	443
Editing.....	337	Deleting	461
Monolithic Slab	220	Dimensions to	726
Size.....	220	Displaying.....	458
Stem wall.....	337	Doors.....	448
Stepped.....	207	Dormer Holes	452
Foundation		Editing	460
Auto Rebuild.....	336	Floor.....	443
Defaults.....	330	Headers.....	448
Tab	219, 331	Joists.....	441
Thickness	220	Keeping current.....	461
Walls.....	183	Lap Joints	443
Foundations		Layer	209
Alignment	337	Lookouts	451
Build.....	334	Manual vs. Automatic	437
Daylight Basement	340	Materials List.....	462
Delete	338	Mitered Joints.....	461
Display	335	Mixing Trusses with Stick.....	475
Footing size	220	Plates	447
Garage	338	Platforms	443
Piers	332	Posts	449
Rebar	333	Reference Marker.....	454
Room supplies floor	247	Represented by single line	771
Slab at top of stem wall	332	Rim Joist.....	443
Slab thickness	332	Roof	451
Slab Tools	341	Rough Openings.....	448
Stem Wall	332	Sill Plates.....	437
Step markers	332	Specification Dialog	463
Stepped.....	340	Steel.....	461, 463
Types.....	331	Structural Member Reporting.....	898
Use Mesh	333	Stud Spacing.....	447
Walkout Basement	340	Stud Thickness.....	447
Walls.....	220	Tools	440
Framing		Trimmers	448
		Trusses.....	453
		Types	463

Wall Blocking	447
Walls	446
Windows	448
Full	
Height Cabinets.....	509
Overview	673–674

G

Gable	
Gable/Roof Line Tool.....	382
Over Door/Window	382
Garage	
Door panels	269
Door Tool.....	256
Garages	
Foundation.....	338
Garden Bed	
Kidney Shaped.....	548
Polyline.....	548
Round.....	548
Tools	548
General	316
Cabinet Defaults.....	508
Framing Tool.....	440
Preferences	67
Wall Defaults.....	176
Getting Help	37
GFCI Outlet	487
Girder Trusses	478
Glass, Stained	283
GPS	
Importing	570
Grade beams	331
Grayscale	
On Screen	63
Printed.....	856
Grid	
Materials list reports	83
Snaps	59, 112
Ground Fault Circuit Interrupt	487

H

Half	
Walls.....	225
Half-Walls	181
Hardiness Zone Maps	579
Hardware	
Lock Issues	911
Hardware Tab	
for Doors	276
Hatch	
Fill Patterns	792
Wall	188
Headers	448
Height	
Basement ceiling	332
Railings.....	226
Help	
Display.....	28
Tool Tips	37
Hill / Valley	
Specification Dialog	561
Hill/Valley	546
Hip	
Truss	475
Holes	
In terrain	547
Home Designer	
Product Key.....	37
Version Number.....	37
Hotkeys	29, 99
Snap Behaviors	110
House Wizard	191, 799
Editing Rooms	800
Multiple Floors.....	801
Placing Rooms	800

I

Icons	
Arrange	660
Image	

Specification Dialog.....	809
Images	698
Adding to Library.....	807
Creating.....	807
Displaying.....	807
Displaying in color.....	63
Editing.....	808
Place.....	806
Printing.....	857
Select from library.....	575
Transparency Color.....	811
Import	
2D DXF/DWG Files	829
3D Data	836
3D Symbols	838
Drawing Wizard.....	829
DXF Elevation Data.....	572
GPS Data	570
Terrain Data	567
Terrain Wizard	568
Input	
Arc	785
Line.....	777
Point	773
Insert	
Floor Dialog.....	318
Insulation	795
Interior	
Dimension Tool.....	730
Dimensions, Auto.....	731
Fireplace, wall.....	344
Room types	235
Invisible Walls	186, 216

J

Join Roof Planes	367
Joist	
Direction Line.....	457
Joist Direction	
Specification Dialog.....	457
Joists	441
Bearing Line	456
Blocking	442

Use Framing Reference	444
see also Framing	

K

Key Frames	820
Keyboard	
Commands.....	29, 99, 607
Kidney Shaped	
Garden Bed.....	548
Pond.....	548
Terrain Features.....	547
Kingpost	480
Kitchen Island	522
Knee Walls	206, 218

L

Label Tab	885
Labels	
Cabinet	515
Display size.....	63
Displaying.....	884
Door	258
Electrical.....	490
Roof Plane	364
Room.....	236
Trusses.....	474
Window	288
Landing	406
Unlocked.....	407
Landings	
Custom Shapes.....	407
Height.....	407
Locked.....	408
Landscape Designer	537
Layer	
Display Options Dialog.....	104
Layer Sets	103
Layers	
Colors.....	105
Locking	103

Primary and Secondary	102	Search	609
Turn off to speed up 3D views	716	Shortcuts.....	617
Layout		Third Party Libraries	613
CAD	868	Trash	617
Create	865	Library Browser	604
Cross Section/Elevations	870	Adding Items	613
Defaults	863	Docking.....	608
Editing Views	870	Panels	604
Exporting	875	Preferences.....	65
Files, Opening.....	48	Restore Position	66
Floor plan view.....	869	Library Object	
Links, Managing.....	873	Specification Dialog	627
Missing Files.....	873	Library Object Button	
Open View	865, 871	Specification Dialog	623
Page Display Options	872	Library Objects	
Pictures in.....	869	and the Materials List.....	625
Preparing for.....	864	Editing	625
Printing	846, 875	Placing.....	620
Resizing, Non-Scaled Views	871	Light	
Resizing, Scaled Views.....	871	Ambient.....	699
Saving	44	Specification Dialog	706
Sending views to	866	Light Sources	699
Text.....	868	Added Lights	700
Layout Box		Default Lights	700
Labels.....	872	Default Sun Light.....	702
Specification Dialog.....	875	Fixtures.....	700
Layout Files Dialog	874	Parallel Lights.....	705
Layout Views		Point Lights	705
Copy.....	871	Spot Lights.....	705
Keeping views current	869	Sun Angles.....	701
Left Mouse Button		Lights	
Definition	26	Added	700
Legacy Plans		Adjust	704
Page Setup	66	Attenuation.....	496
Text Conversion	64	Casts Shadows.....	495
Legends	747	Color.....	494
Library		Connect to switch	488
Adding Folders.....	615	Custom Intensity.....	495
Bonus Catalogs.....	610	Cut Off Angle.....	495
Content.....	609	Direction	494
Deleting Content	617	Drop Off Rate	495
Export.....	620	Fixtures.....	487, 700
Filter Tree View	618	Floor Number	706
Manage Library Filters Dialog	619	Height	706
Manufacturer Libraries.....	610	Intensity	494
Renaming Libraries	616	Light Data Tab.....	493

Show Position in 3D	495
Turn On/Off	703
Types of sources	705
Line	
Angle Format	770
CAD Drawing Tools	776
Endcaps	75
Length Format	770
Properties Panel	75
Specification Dialog	780
Start and End Points	77
Tab	780
Weight	842, 849
Weight Scaling	850
Weights, Show	62, 845
with Arrow	778
Line Style	
Tab	781
Lites	
Craftsman	303
Diamond	303
Doors	273
Normal	303
Prairie	303
Tab	302
Living Area	237
and Room Types	235
Calculation	238
Delete label	237
Label	237
Restore label	237
Show	59
vs. Footprint	238
Loan Calculator	802
Locate	
Roof Plane Intersections	367
Lock	
Layers	103
Roof planes	371
Tread Depth	410
Lookouts	451

M

Main	
Edit Mode	116
Layer	209
Make	
Parallel Dialog	162
Parallel/Perpendicular	155, 162
Manage	
Layout Links	873
Library Filters	619
Materials Lists	896
Manual	
Dimensions	729
Roofs	350, 362
Manufacturer Libraries	610
Marker	762
Defaults	744
Editing	764
Framing Reference	454
Specification Dialog	763
Tab	763
Types	764
Marquee Select	126
Masonry	
Fireplace	344
Stairs	419
Master List	899
Columns to display	84
File Location	84
Materials List	84
Name of file	84
see also Materials List	
Update to Master	901
Material	
Defaults	651
Eyedropper	634
Material Painter	632
and Walls	634
Blending	633
Modes	632
Using	633
Materials	
Add to Library	614
Artwork	639

Blending	638	Middle Mouse Button	27, 654
Calculating amounts	592	Mitre Ends of Angle Walls	447
Create using Color Chooser	652	Model Maker	
Creating.....	637	Floor Plan View Template	860
Define Material Dialog	644	Printing	858
Editing	636	Molding	
On Soffits.....	592	in Rooms.....	250
Plan Materials Dialog.....	642	Moldings Tab	503
Render properties.....	650	for Rooms	250
Stained glass	283	for Windows	299
Tab.....	635	Mouse Buttons	
Textures	648, 697	Using	26
Types	640	Move	
Walls	193	Along Rails.....	199
Materials List	887	CAD Points.....	775
Calculate from All Floors.....	888	Folders and Library Objects.....	616
Calculate from Room	888	Object Using Dimensions	737
Categories	82	Objects	152
Columns, editing	892	Restrictions	153
Conditioned Areas.....	898	to be Coplanar	368
Display Options Dialog	891	to Framing Reference	154
Editing.....	895	to Front of Group	151
Estimating software	897	Walls with Cabinets Attached	518
Export.....	897	Move Point Dialog	775
Font.....	64	Mulled Unit	
Framing	462	Specification Dialog	294
Grid display on reports.....	83	Mulled Units	
Library Objects.....	625	Framing.....	297
Manage	896	Labels	297, 885
Master List Preferences	84	Mullion Depth	297
Preferences	82	Treat as Door	297
Report Style Preferences	83	Mullions	
Restrict to Floor.....	892	Window	302
Restrict to Supplier	892	Multiple	
Saving	888	Floors, Reverse Plan	164
Subcategories	85	Select	126
Max Tread Contraction	417	Muntins	
Menus	30	Window	302
Mesh, Specify for foundation	333	New	
Message Boxes		CAD Arc Dialog	785
Reset.....	32		
message URL http			
//www.homedesignersoftware.com/			
useraccess/content.html	611		
Metafile Size Dialog	815		
Metafiles	814		

N

CAD Line Dialog	777
CAD Point Dialog	773
Plans Preferences	71
Polygon Shaped Room	187
Newels	
Definition	399
Newels/Balusters Tab	226
No Locate Wall	216
North Pointer	778
Number Style/Angle Style	
Dialog	89

O

Object	
Based Design	25
Object Snaps	110
Extension Snaps	111
Object locations	110
Preferences	79
One-Click Auto Dimension	730
One-Click Stairs	398
Open	
Below	235
Layout	48
Object	31
Plan Files	48
Symbol	627
View	690
OpenGL	664
Openings	
Dimensions to	725
Headers	448
Ignore casing for resize	58
Optimizations On	86
Options Tab	360
Organizing	
your Files	40
Orthogonal Views	847
Outlets	487
Above cabinet	491
Automatic	489

Dishwasher	487
For appliance	491
GFCI	487
Manually placed	487
Place	489
Sink	487
WP	487
Oval	789
Specification Dialog	789
Overall Dimension	728
Overhang	363
Overview	23
Camera tools	682
Full	674

P

Page Setup Dialog	853
Legacy Layouts	66
Legacy Plans	66
Painting	
Over Materials	638
Pan	
Pan Window Tool	656
the Display	655
Using the Keyboard	655
Using the Mouse	656
Using the Scroll Bars	655
Paragraph Options Dialog	749
Parallel Light	705
Parent Buttons	94
Partition Tool	510
Pass-Thru	282
Paste	115
Hold Position	117
in Place	117
Special	117
Pattern Tab	647
Patterns and Textures	638
PDF	
Print to	848
Peninsula Radius Cabinets	521

Personal Tutor	910	Create.....	574
Picture		Specification Dialog	574
Copy Region as.....	819	Plinth Blocks	269
Displaying in color	63	Plot Plan	
Picture File Box		North pointer	778
Specification Dialog.....	813	Plotters	843
Picture Files		Point	
Export.....	811	Light	705
Import.....	812	Markers.....	774
Scale	817	Point to Point	
Piers		Dimensions	730
and Pads	341	Move.....	153
Foundation.....	332	Resize.....	818
Piers and Pads		Pointer	
Editing.....	341	Coordinates.....	32, 62
Pitch		Cross Hairs	76
Above Wall	204	Polygon	
Show as degrees.....	59	Shaped Deck.....	182
Place		Polyline	
Gable Over Window(s).....	283	Area.....	791
Images	806	Definition.....	790
Library Object Button.....	623	Edit Area	169
Library Objects.....	620	Garden Bed.....	548
Outlets.....	236, 489	Rectangular Polyline Tool	794
Plan		Specification Dialog	791
Create New.....	42	Tab	792
Drawing	33	Ponds	548
Files, Opening.....	48	Round	548
Find Plan Wizard.....	50	Pony Walls	184
General Defaults	58	Align upper and lower	179
Materials Dialog	642	Change wall types	185
Saving.....	43	Default height	179
Trace.....	818	Display.....	194
View	35	Display Openings in	179
Plan Check	801	Show lower wall.....	179
and room labels.....	236	Post	440
Dialog	802	Specification Dialog	465
Hold.....	802	Preferences	
Restart.....	802	Appearance Panel	61
Plant		Architectural Panel.....	73
2D Symbols	575	Behaviors Panel	78
Chooser Dialog	577	CAD Panel	74
Encyclopedia	577	Categories Panel	85
Tools	573	Colors Panel.....	63
Plant Image		Definition of.....	57

Connect walls.....	192	Render	
Decks	182	Added Lights	700
Fix connections	192	Daytime Ambient	700
Glass.....	186	Graphics card	664
Half Walls	181	Interior Ambient	700
in a Doorway.....	264	Light Fixtures.....	700
Locate with dimensions.....	216	Light Sources	699
Middle Rail.....	225	Nighttime Ambient	700
Newels	226	Preferences.....	86
No Rail	225	Status	88
Open	225	Tips	697
Openings	264	Render Data Tab	709
Solid	225	Rendering Techniques	710
Stairs.....	416	Backdrops in	672
Raised / Lowered Region		Defaults	713
Specification Dialog.....	562	Options	713
Ramp		Replace from Library	
Slope.....	431	Button	624
Specification Dialog.....	430	Dialog	624
Rebar		Report Style Preferences	83
In Foundations	333	Reset	
Rebuild	355	Defaults	59
3D	689	Message Boxes	32
Roof Framing	378	Preferences.....	89
Roofs.....	355	Reshape objects	158
Walls/Floors/Ceilings	324	Resize	
Recent File List	69	Enable for symbols	59
Recessed		Factor	818
Doors	264, 269	House using Dimensions.....	738
Windows.....	283, 297	Ignore casing.....	58
Rectangular Polyline	794	Objects	157
Redo	173	Point to Point.....	818
Reduce Gable	481	Restore	
Reference		Toolbars.....	92
Display Options	328	Restrictions	
Grid	59	Moving objects	153
Reflect		Retain	
About Object.....	163	Wall Framing	218
Objects.....	163	Retaining Wall	550
Relative		Reverse	
to Current Point, new point.....	773	Plan	164
Remove		Rich Text	
3D	680	Border Color.....	750
Backdrop	672	Defaults	744
		Specification Dialog	747

Text Color.....	748	Join	367
Right Button Definition	26	Low roof planes.....	359
Rim Joist	443	Move to be Coplanar	368
Road		Raising/Lowering.....	368
Specification Dialog.....	586	Roof Truss	
Road Objects		Specification Dialog	479
Different Types	584	Roofs	349, 355
Roads	584	Auto Rebuild	355–356
Displaying.....	585	Auto Roof Return.....	219
Roof	349	Automatic vs. Manual	350
Automatic	350	Boxed Eaves	360
Baseline Polyline.....	375	Build Roof Dialog.....	355
Baseline Polyline, Example Using	376	Crickets	390
Baseline, Angled	373	Defaults	351
Baselines.....	363	Dormers.....	387
Beams.....	441	Eaves, aligning.....	368
Birdsmouth Cut	371	Energy Heel	476
Birdsmouth Depth	373	Fix Roofs Tool.....	353
Extend Slope Downward.....	218	Framing	451
Full Gable Wall	218	Gutters	394
Groups	353	Heights	372
Over this room	247	Hip Trusses.....	475
Pitches in Degrees	395	Hole for skylights.....	385
Second pitch.....	219	Ignore Top Floor.....	358
Styles, Automatic	353	Knee walls	206
Tab	218	Lock roof planes.....	359, 371
Tools	352	Manual.....	362
Truss.....	470	Minimum Alcove Size.....	360
Truss Specification Dialog	479	Over Alcoves.....	384
Roof Baseline		Over curved walls.....	354
Specification Dialog.....	377	Overhang.....	357, 363
Roof Beams	590	Pitch	204, 372
Roof Designer	352	Plumb Cut Eaves.....	360
Roof Hole/Skylight		Raise off plate	359
Specification Dialog.....	386	Retain edits.....	374
Roof Plane		Returns.....	393
Labels	364	Roof Group	245
Specification Dialog.....	371	Roof Plane	352
Roof Planes	352, 362	Show pitch as degrees.....	59, 373
Aligning	366	Skylights	385
Area	374	Square Cut Eaves	360
Delete	371	Step Down Hip	475
Display	364	Story-and-a-half	206
Edit	365	Subgirders	476
Intersections, Locate	367	Trusses.....	358
		Upslope Mark	363
		Vertical Rafter Depth	373

Room	230
Defaults	230
Specification Dialog	244
Room Labels	236
Custom	236
Defaults	230
Display	237
Edit	237
Interior room area	237
Interior room dimensions	237
Room area	237
Standard room area	237
Rooms	
Area	237
Attic	235
Auto Place Outlets	236
Below Stairs	421
Ceiling over	247
Editing	233
Exterior types	235
Foundation floor definition	247
Interior	235
Interior area	237
Interior dimensions	237
Living Area	235
Name for PlanCheck	802
Open Below	235
Polygon Shaped	187
Roof over	247
Room Definition	231
Room Types	235
Selecting	231
Standard area	237
The Exterior Room	232
Types	234
Rotate	
CAD items	78
Jump	78
Plan View	163
Rotate objects	161
Rough Openings	448
Round	
Garden bed	548
Pond	548
Window	308

S

Same	
Height Eaves	359
Roof Height at External Wall	359
Sash and Frame Tab	301
Save	
3D Views	690
and Save As	43
Layout	44
Plan	43
Plan Thumbnail	46
Scale	
Picture Files	817
Printing to	847
Terrain Data	569
Text Size	755
to Fit	847
Schedule	
Specification Dialog	880
Schematics, Wiring	488
Scissors Trusses	478
Scroll Bars	655
Seat	
in Bay Window	292
Section Views	
Create	675
Segment Angle at Curved Wall	359
Select	
Backdrop	672
Components of Blocked Units	284
Library Object Dialog	622
Marquee	126
Multiple Objects	126–127
Next Object	126
Object Parts	125
Objects button	124
Objects in 3D Views	688
Room	231
Selected Edge	125
Shift+Click	127
Similar Objects	124
Selection Fill Color	64
Send	

to Layout Dialog	867	Extension Snaps	111
Views to layout.....	866	Grid Snaps.....	59, 112
Service Data Tab	492	Hotkeys	110
Set Angular Dimension Dialog	162, 739	Object locations.....	110
Set Baseline Height Dialog	370	Object Snaps	110
Shadows	702	Snap Properties	
Shelf	510	Preferences	79
Shelf Tool	510	Soffit	
Shelf/Partition		Defaults	589
Specification Dialog.....	533	Specification Dialog	592
Shelves in Cabinets	532	Soffits	510, 589
Shift Key		Calculating Materials	592
Marquee selection.....	126	Corner	590
Select multiple objects.....	127	Place under ceiling	594
Short Extensions	727	Place under Roof.....	594
Shortcut Keys	29, 99	Sloped	594
Show		Special applications.....	590
Arc Centers	134	Space Planner	
Line Weights.....	62, 845	Toolbar Configuration	98
Living Area	59	Special	
Pitch as degrees	59	Shaped Cabinets.....	520
Sheet	845	Specification Dialogs	
Short extensions	727	Arc	786
Shutters	310	Bay/Box Window	311
Sidewalk	584	Bow Window	313
SidewalkTools	584	Cabinet	522
Sill Plates	437	Cabinet Shelf	532
Skylights	352, 385	CAD Box.....	795
Slab		CAD Circle.....	789
At top of stem wall.....	332	CAD Ellipse.....	789
Foundation	332	CAD Oval.....	789
Monolithic, Footings	220	Callout	760
Specification Dialog.....	342	Camera	691
Slabs		Ceiling Plane.....	380
and the Materials List	341	Corner Boards	499
Interior Footings.....	337	Cross Section/Elevation Camera	694
Slab Tool	341	Custom Countertop.....	535
Tools.....	341	Default Sun Light.....	707
Sliding Doors	255	Dimension Line	739
Sloped Soffits	594	Door	265
Snap Behaviors	109	Dormer	391
Angle Snaps	111	Electrical Service.....	492

Flat Region	560	Spot Light	705
Framing	463	Sprinkler	
Hill / Valley.....	561	Designer	580
Image	809	Specification Dialog	580
Joist Direction	457	Tools.....	580
Layout Box.....	875	Stacked Windows	284
Library Object	627	Stair	
Library Object Button.....	623	Landing Specification Dialog	433
Light	706	Sections Move Independently	74
Line	780	Tools.....	398
Marker	763	Stair Designer	398
Plant Image.....	574	Stair Landing	
Polyline.....	791	Specification Dialog	433
Post.....	465	Stair Landings	
Quoins.....	501	Custom Shapes	407
Raised/Lowered Region.....	562	Height	407
Ramp.....	430	Locked	408
Rich Text	747	Stair Railing	
Road	586	Panels.....	418
Roof Baseline.....	377	Partial	416
Roof Hole/Skylight.....	386	Solid	417
Roof Plane	371	Stair Treads	
Room.....	244	Automatic	423
Schedule	880	Depth.....	424
Shelf/Partition	533	Lock Number	423
Slab.....	342	Lock Tread Depth	423
Soffit.....	592	Number	424
Sprinkler	580	Overhang	427
Stair Landing.....	433	Thickness.....	427
Staircase	422	Staircase	
Sun Angle.....	708	Specification Dialog	422
Terrain.....	554	Stairs	
Terrain Break	564	Align Curved Stairs	157
Terrain Feature	562	Auto Stairwell	419
Terrain Path	566	Change Line/Arc	405
Text.....	753	Click	398
Wall.....	214	Concrete	418
Wall Hatch	227	Curved	398, 401
Window.....	294	Curved Treads.....	413
Speed		Deck to ground	402
3D View Generation	716	Direction	400
3D views.....	670	Down	402
Splines	796	Edit Handles.....	403
Split		Editing	403
Level Entries	326	Flare Radius.....	411
Level Floor Plans	325		
Walls	189		

and 3D Draw Time.....	552	Layer	747
Auto Rebuild	552	Layout.....	868
Breaks	544	Line Spacing	749
Build	552	Move.....	754
Clear	540	Numbering	749
Contour Lines.....	551	Paragraph Options.....	749
Contour Smoothing.....	556	Printed Size.....	755
Displaying.....	551	Printing	851
Editing	552	Reshape	754
Elevation Data Tools	540	Resize.....	755
Feature Tools.....	546	Rotate.....	754
Flat Region	546	Scaling.....	755
Grow All Plants Dialog	573	Specification Dialog	753
Hill.....	546	Text Style Defaults Dialog	765
Holes	547	Text Styles	765
Modifier Tools	545	Texture	
Specification Dialog.....	554	Filename Conflict Dialog	839
Sprinkler Tools.....	580	Tab	648
Sun Shadows	550	Textures	697
Toolbar Configuration	98, 538	Mapping	638
Valley	546	View.....	648
Wall and Curb Tools	549	Thumbnails	46
Terrain Break		Creating	46
Specification Dialog.....	564	Enable	69
Terrain Data		Size	69
Convert CAD Lines to	573	Tiling Views	659
Import.....	567	Toolbars	28
Terrain Feature		Add Tools.....	93
Specification Dialog.....	562	Child Buttons.....	94
Terrain Features		Configurations	98
Clip.....	562	Customize	93
Height.....	562	Delete Tools	94
Terrain Modeler		Drop-Down	92
3D Views	552	Edit.....	29
Clear Terrain.....	540	Hide.....	92
Terrain Path		Parent Buttons.....	94
Specification Dialog.....	566	Parent-Child	92
Terrain Perimeter	538	Restore	92
Text		Tool tips	28
Arrows	757	Transform/Replicate Object Dialog	167
Bullets	749	Transom Windows	264
Character Size	745	Transparency	
Copy, Cut and Paste.....	756	Color.....	811
Creating.....	746	Treated	
Displaying.....	747	Lumber	465
Editing	754		

Sill Plates	437
Treatments Tab	308
Trim	
Door	260
Window	290
Trimmers	448
Truss	
Envelope	474
Trusses	358, 453
Attic trusses	477
Ceiling Steps	478
Copy	470
Create	470
Double	476
Drop Hip truss	480
Edit	473
End truss	480
Energy Heel	476
Floor and Ceiling	470
Force Truss Rebuild	481
Force truss rebuild	483
Girder	478
Hip	475
Hip jack	475
Jack	475
Kingpost	480
Labels	474
Laying out	470
Lock Envelope	481
Member Depth	480, 482
Mixing with rafters	475
Reduce gable	481
Roof	470
Scissors	478
Shape, editing	474
Special Snapping	481
Step Down Hip	475
Subgirders	476
Webbing	481–482

U

Undo	173
Files	48
Preferences	67

Undo Zoom	654
Unit Conversions	71
Unrestricted Movement	153
Untitled Plan	
see New Plan	
Updates	
Auto Check	68
Use Layout Line Scaling	867

V

Valley	546
Vaulted Ceilings	242
Vents	283
Video Card	
Memory	664
OpenGL	664
Status	88
Videos	
View Online Help Videos	906
Views	
Cascade	657
Static and Dynamic	869
Tiling	659
Virtual Graph Paper	58
Visual CAD Snaps	58
Volume	
Of a Polyline	792

W

Walk Line	409
Walkthroughs	819
Along a Path	819
Codecs	823
Create Path	819
Key Frames	820
Pause Recording	822
Playing	823
Recording	822
Save Frame	822
Stop Recording	822

Wall

Assemblies 209
 Blocking..... 447
 Cabinets 509
 Defaults 177
 Elevation..... 673
 Layer Fill Style 214
 Specification Dialog 214
 Tools 181
 Type Definitions Dialog..... 211
 Types Tab..... 221

Wall Hatch

Specification Dialog..... 227

Wall Type Definitions Dialog..... 211

Walls

Align between floors 202
 Align colinear 202
 Align pony walls 179
 and Material Painter 634
 Attic Walls..... 206, 216
 CAD to Walls..... 208
 Compound Raked..... 208
 Connecting 191
 Curved..... 190
 Curved, align between floors..... 203
 Delete hatching 188
 Dimensioning to 210
 Display surfaces only..... 192
 Drawing 189
 Editing 197
 Exterior and Interior..... 183
 Fill styles 214
 Fix Connections 192
 Flip layers 189
 Footing size 220
 Foundation..... 183, 220
 Foundation thickness..... 220
 Framing 446
 Framing Layer..... 209
 Full Gable Wall..... 218
 Grid snapping..... 190
 Half 225
 Half Walls 181
 Hatching 188
 Heated Area..... 195
 Heights 199
 Interior, fireplace in..... 344

Invisible..... 186, 216
 Knee Wall..... 218
 Layer fill style 214
 Layers..... 209
 Layers, Resize About 176
 Length..... 200
 Main Layer 209
 Materials 193
 Move Along Rails..... 199
 No Locate..... 216
 No Room Def..... 216
 Opening with Railing 264
 Openings in 190
 Pony Wall..... 184
 Pony wall height 179
 Raked 207
 Removing Breaks 192
 Resizing Using Dimensions 738
 Retain wall framing 218
 Retaining Wall 550
 Reverse Layers 189
 Roofs over curved..... 354
 Room Def (invisible) 216
 Same Wall Type handles..... 198
 Show length when editing..... 177
 Show lower pony wall..... 179
 Solid Railings 225
 Split 184
 Stepped 207
 Thickness..... 199
 Wall Coverings 223
 Widths, Dimensioning 740

Water Features 548

Water Proof Outlet 487

Webbing

Thickness..... 483

Winders 414, 425

Definition..... 399

Window

Casing 290
 Casing, reveal 298
 Defaults 280
 Seat..... 292
 Specification Dialog 294
 Trim 290

Windows

Bay & bow dimensions	291
Bay Box & Bow	290
Bench Seat	292
Cascade	657
Component	281, 291
Corner	282
Egress	296
Framing	448
Gables Over	382
Labels	288
Levels	285
Library	282
Match roof	306
Minimum Separation	280
Mulled Units	284
Mullions	302
Muntins	302
Opening Indicators	288
Pass-Thru	282
Recessed	283, 297
Shutters	310
Special Shapes	283
Stacked	284
Stained glass material	283

Standard	281
Transom	264
Treatments	308
Types	280
Vents	283
Windows Metafiles	814
Wiring Schematics, Creating	488
Wrapped	
Openings	263
Stairs	415

Z

Zero	
in Dimensions	723
Zoom	654
Fill Window	655
Mouse Wheel	27, 654
Tools	654
Undo Zoom	654

